



Manufacturing, Design, Entrepreneurship
New Zealand

MaDE2020: Synergies in
New Zealand Manufacturing,
Design and Entrepreneurship



7-8 December 2020
The Great Room, Cordis Hotel, Auckland

MaDE2020 HANDBOOK ADDENDUM

Page 6 (see **paragraph** overleaf):

MaDE NZ: Strategic Pathway for the MaDE Network

Our current project timeline has been extended to 31 December 2021.

PROGRAMME CHANGES

Page 8:

MIHI presenter: Jeremy Hēma (remote presentation)

Page 9: CONCURRENT CONFERENCE SESSION 1, Great Room 4

Revised abstract title (programme):

ADDITIVE MANUFACTURING IN THE AVIATION INDUSTRY

Presenter: Andrew Hewitt, Air New Zealand

Page 13: CONCURRENT CONFERENCE SESSION 3, Great Room 4

Presenter switch: John Kennedy to present on behalf of Jérôme Leveneur

Page 13: CONCURRENT CONFERENCE SESSION 4, Great Room 3

Abstract withdrawn (programme): THE DESIGN FOR ADDITIVE MANUFACTURING OF COMPLIANT MECHANISMS FOR APPLICATION IN THE AVIATION INDUSTRY by Ishaan Singhal

PANEL DISCUSSION 2, Great Room 4

Panellist unavailable (programme): Harry Burkhardt

ADDITIONAL PAGE CONTENT CHANGES

Page 19: **Presenter withdrawn** (Student Innovation Showcase): Shuo Xu

Page 22: **Panellist unavailable:** Harry Burkhardt

Page 54: **Abstract title change:**

ADDITIVE MANUFACTURING IN THE AVIATION INDUSTRY

Presenting Author change: Hewitt, Andrew – Air New Zealand

(Thomas, Wayne – Air New Zealand; and Singamneni, Sarat – AUT, attending as co-authors)

Presenter bio change: Andrew Hewitt is currently Air New Zealand's Head of Planning Design and Support. Prior to joining Air NZ in 2008 he worked as an engineer for the Royal NZ Air Force, having also worked as an engineer in the Royal Air Force.

Page 83: **Presenting Author change:** Kennedy, John – GNS Science

(Leveneur, Jérôme – unavailable author)

Presenter bio change: John Kennedy is a physics-based materials scientist focused on applied surface science for technological innovation. His team develops new materials to support technologies for a low carbon future. He has published more than 20 international patent applications and 200 journal papers on nanostructures and surface modification of materials.

Page 95: **Abstract withdrawn**

Page 142:

Add to index:

Author: **Hewitt, Andrew** | Organisation: Air New Zealand | Page **54**

Author: **Kennedy, John** | Organisation: GNS Science | Page **83**

Remove from index:

Author: Leveneur, Jérôme

MaDE NZ: Strategic Pathway for the MaDE Network - replaces page 6

From its initiation in 2016 the MaDE Network has connected NZ researchers in manufacturing, design and entrepreneurship with each other and with relevant NZ industry. Spawned out of a strategic project of the IMM Programme at the University of Auckland, the MaDE Network positioned itself to apply for a Centre of Research Excellence (CoRE) in November 2019.

In May 2020, a formal announcement by the Royal Society Te Apārangi delivered the disappointing news that the MaDE CoRE had not been shortlisted through to the next stage of the selection process of Tertiary Education Commission funded CoREs. There was no context to this decision and no feedback has been provided.

The strategic thinking of the MaDE Leadership Team emerges from the premise that we have successfully established MaDE NZ – a significant and collaborative national network of researchers, industry stakeholders and government representatives crossing the disciplines and sectors of manufacturing, design and entrepreneurship.

Our **MISSION** of developing expertise and capability in translational research, to grow New Zealand's high-tech manufacturing economy still holds, as does our **VISION** for New Zealand to be recognised as a leading, technology empowered economy driven by innovative, high-value, niche manufacturing, design and entrepreneurship.

As the COVID-19 dust continues to settle, with current funding, we have been able to successfully deliver:

- **MaDE2020 (DIGITAL)** - an online virtual event, as a highlight package during Techweek on 29 July 2020.
- **MaDE2020** – a physical conference, within NZ government COVID-19 regulations, in Auckland on 7-8 December 2020.

Our current project timeline has been extended to 31 December 2021. This includes available funding to **seed MaDE2021** and remuneration of an Operations Coordinator. However, future MaDE NZ related activities will necessitate alternative funding sources, which will be challenging in the post pandemic economic recovery phase. We believe that we have a strong value proposition and that we will be able to identify funding mechanisms as enablers to sustainably continue our pathway and build a track record whereby:

- The ongoing connectedness and unification of our MaDE Network is upheld.
- We continue to build university-industry research linkages and programmes.
- The delivery of future annual MaDE conferences is enabled.
- Innovative research across the MaDE disciplines is supported.
- A national, cross-disciplinary MaDE education programme, which produces industry-ready post graduate students, is developed.

We hope that you and your organisations will continue to support MaDE NZ in whatever way you are able in the weeks, months and years to come.

Please make the most of the opportunities at MaDE2020 to engage with fellow delegates.

MaDE2020 is presented by the University of Auckland's IMM Programme and proud to be sponsored and supported by our valued stakeholders



BRONZE



GOLD



SUPPORTERS



SILVER



Contents

MaDE NZ Strategy	6
NZ MaDE Network	7
Programme	8
Student Innovation Showcase Presenters	18
Panel Discussions	20
Student Innovation Showcase	24
Prizes and Awards	25
Key Presenters	28
Oral Abstracts	34
Poster Abstracts	112
Presenters Index	142

Venue WiFi

Network: Cordis

Username: MADE20

*to log onto wifi please select the network CORDIS, when prompted please enter the access code MADE20. Be aware you may need to reconnect after 24hrs.

The New Zealand Manufacturing, Design and Entrepreneurship (MaDE) Conference Committee members are delighted to welcome you to our fourth national conference – MaDE2020: Synergies in New Zealand Manufacturing, Design and Entrepreneurship

This event follows on from the successful and well-received MaD2017, MaD2018 and MaD2019 Conferences. MaDE2020 has a focus on developing and enhancing valuable collaborations between researchers and industry to enable us all to synergistically work together towards an expanding and more prosperous future for the New Zealand manufacturing, design and entrepreneurship sectors.

The MaDE Network is a cross-disciplinary community of New Zealand researchers in manufacturing, design and entrepreneurship that works in close collaboration with industry to envision and shape New Zealand’s future manufacturing economy. The MaDE mission is to develop expertise and capability in translational research to grow New Zealand’s high-tech manufacturing economy. The MaDE vision is for New Zealand to be recognised as a leading, technology empowered economy driven by innovative, high-value, niche manufacturing, design and entrepreneurship.

The Covid-19 pandemic and the geographical advantage of New Zealand, together with our innovative and world-leading reputation, have highlighted the importance and necessity for us to further identify and capture new opportunities in the manufacturing, design and entrepreneurship sectors. An important aspect of MaDE2020 is to present innovative and strategically important research that can underpin this, as well as enabling us to work together to grow new knowledge and expertise accordingly. University-industry research linkages and collaborations are integral here. Through improving collaboration between Māori, researchers and industry we aim to enable the innovation potential of Māori knowledge, resources and people.

We hope that you will enjoy the Conference and find both the content and networking valuable. We are very pleased with the support, interest and attendance of both the research and industry sectors from across the national MaDE Network, especially since circumstances forced the postponement of MaDE2020 from earlier in the year.

Some 74 oral presentations split between industry organisations and researchers, all showcasing exciting research projects across a wide range of areas will be presented. We are pleased to be able to bring you four high-calibre key presenters who are leaders in their fields and have excellent insight into manufacturing, design and entrepreneurship both locally and internationally. We invite you to engage and contribute during our three Panel Discussion sessions, each led by a senior University of Auckland researcher, which will cover a selection of relevant and important topics. Please take the opportunity to review and discuss the research work being showcased in each of the 29 poster presentations, spend time absorbing and interacting with the exhibition booth content, and network during the refreshment breaks. There is also a Student Innovation Showcase where 26 postgraduate students will be presenting examples of their manufacturing and design innovations.

On behalf of the MaDE2020 Conference Committee, we wish to thank our partners, sponsors and supporters for acknowledging the significance of this event in our national manufacturing, design and entrepreneurial landscape; and especially for standing by with support following the requirement to postpone our event due to COVID-19. Most importantly, thank you to all delegates for joining us.

Yours sincerely,

Professor Jim Johnston *MaDE2020 Co-Chair, Victoria University of Wellington*

Professor Olaf Diegel *MaDE2020 Co-Chair and MaDE Network Leader, The University of Auckland*

MaDE NZ: Strategic Pathway for the MaDE Network

From its initiation in 2016 the MaDE Network has connected NZ researchers in manufacturing, design and entrepreneurship with each other and with relevant NZ industry. Spawned out of a strategic project of the IMM Programme at the University of Auckland, the MaDE Network positioned itself to apply for a Centre of Research Excellence (CoRE) in November 2019.

In May 2020, a formal announcement by the Royal Society Te Apārangi delivered the disappointing news that the MaDE CoRE had not been shortlisted through to the next stage of the selection process of Tertiary Education Commission funded CoREs. There was no context to this decision and no feedback has been provided.

The strategic thinking of the MaDE Leadership Team emerges from the premise that we have successfully established MaDE NZ – a significant and collaborative national network of researchers, industry stakeholders and government representatives crossing the disciplines and sectors of manufacturing, design and entrepreneurship.

Our **MISSION** of developing expertise and capability in translational research, to grow New Zealand's high-tech manufacturing economy still holds, as does our **VISION** for New Zealand to be recognised as a leading, technology empowered economy driven by innovative, high-value, niche manufacturing, design and entrepreneurship.

As the COVID-19 dust continues to settle, with current funding, we have been able to successfully deliver:

- **MaDE2020 (DIGITAL)** – an online virtual event, as a highlight package during Techweek on **29 July 2020**.
- **MaDE2020** – a physical conference, within NZ government COVID-19 regulations, in Auckland on **7-8 December 2020**.

Beyond 31 December 2020, our current project timeline and available funding will have expired and future MaDE NZ related activities will necessitate alternative funding sources, which will be challenging in the post pandemic economic recovery phase. However, we believe that we have a strong value proposition and that we will be able to identify funding mechanisms as enablers to sustainably continue our pathway and build a track record whereby:

- The ongoing connectedness and unification of our MaDE Network is upheld.
- The delivery of future annual MaDE conferences is enabled.
- Innovative research across the MaDE disciplines is supported.
- A national, cross-disciplinary MaDE education programme, which produces industry-ready post graduate students, is developed.

We hope that you and your organisations will continue to support MaDE NZ in whatever way you are able in the weeks, months and years to come.

Please make the most of the opportunities at MaDE2020 to engage with fellow delegates.

www.madenz.org | www.immprogramme.auckland.ac.nz

NZ's Manufacturing, Design and Entrepreneurship (MaDE) Network

Our MISSION is....

To develop expertise and capability in translational research, to grow New Zealand's high-tech manufacturing economy

Our VISION is...

For New Zealand to be recognised as a leading, technology empowered economy driven by innovative, high-value, niche manufacturing, design and entrepreneurship.

MaDE DRIVER TEAM (STEERING COMMITTEE)

- Olaf Diegel, The University of Auckland (Chair)
- Kenneth Husted, The University of Auckland
- Simon Fraser, Victoria University of Wellington
- Mark Battley, The University of Auckland (IMM Programme Lead)
- Simon Bickerton, The University of Auckland
- Claire Barnsley, The University of Auckland (Operations)
- Mark Taylor, The University of Auckland
- Marcel Schaefer, AUT
- Mike Duke, University of Waikato
- Don Cleland, NSC10 & Massey University
- Johan Potgieter, Massey University
- Shayne Gooch, University of Canterbury
- Debbie Munro, University of Canterbury
- Conan Fee, University of Canterbury
- Robert Blache, Callaghan Innovation
- Allen Guinbert, Fisher & Paykel Appliances
- Catherine Beard, ManufacturingNZ
- Dieter Adam, The Manufacturers' Network

MaDE CONFERENCE COMMITTEE

- Jim Johnston, Victoria University of Wellington (Co-Chair)
- Olaf Diegel, The University of Auckland (Co-Chair)
- Mark Battley, The University of Auckland
- Claire Barnsley, The University of Auckland (Operations)
- Stephanie Szmurlo, The University of Auckland (Event Manager)
- Amanda Wallace, The University of Auckland (Event Coordinator)
- Jonathan Stringer, The University of Auckland
- Yuqian Lu, The University of Auckland
- Marcel Schaefer, AUT
- Paul Woodfield, AUT
- Mike Duke, University of Waikato
- Rachael Tighe, University of Waikato
- Khalid Arif, Massey University
- Tim Miller, Victoria University of Wellington
- Don Clucas, University of Canterbury

Four components, one system: New Automation Technology.

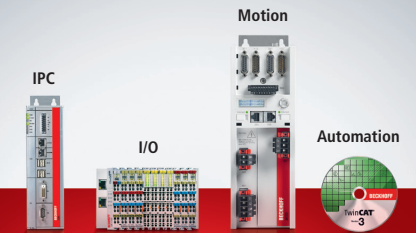

www.beckhoff.co.nz

Setting standards worldwide: PC- and EtherCAT-based control solutions from Beckhoff. As renowned specialists for open automation systems, Beckhoff offers components for IPC, I/O, motion and automation applications that can operate individually or integrated as a precisely adapted control system. New Automation Technology from Beckhoff represents versatile automation solutions that are used in a wide range of applications worldwide. The growing presence of Beckhoff in 75 countries ensures consistent support around the globe.

New Automation Technology **BECKHOFF**

Monday 7 December 2020

8.00am REGISTRATION OPENS:

9.00am CONFERENCE OPENING: GREAT ROOM 4

MIHI: **Jeremy Hēma** (Kaiārahi UniServices)
OPENING: Professor Jim Metson (Deputy Vice Chancellor Research, The University of Auckland)
Session Chair: Professor Olaf Diegel (MaDE2020 Co-Chair, The University of Auckland)

9.30am KEYNOTE SPEAKER: GREAT ROOM 4

Catherine Beard (Executive Director: BusinessNZ, ManufacturingNZ, ExportNZ)
MADE IN NZ - TURBO CHARGING EFFORTS FOR AN ECONOMIC RECOVERY
Session Chair: Professor Olaf Diegel (MaDE2020 Co-Chair, The University of Auckland)

10.00am MORNING TEA: (GREAT ROOM 1) - SPONSORED BY AUT
 POSTER AND EXHIBITION VIEWING (POSTER PRESENTERS TO BE AVAILABLE AT THEIR POSTERS FOR VIEWING AND JUDGING)

10.30am CONCURRENT CONFERENCE SESSION 1

GREAT ROOM 2	GREAT ROOM 3	GREAT ROOM 4
ENTREPRENEURIAL MINDSET AND MANUFACTURING Session Co-chairs: Don Cleland and Paul Woodfield	INDUSTRY 4.0 - AN OVERVIEW Session Co-chairs: Yuqian Lu and Rachael Tighe	ADDITIVE MANUFACTURING - AN OVERVIEW Session Co-chairs: Simon Fraser and Juan Schutte
DESIGNING RESEARCH FOR IMPACT - Don Cleland, Massey University and SfTI	IOT WITHOUT INTERNET OR THINGS - Aryaman Taore , Beckhoff Automation	DEMOCRATISING MEDICAL DEVICES: 3D PRINTING AND OPEN SOURCE SYSTEMS FOR DESIGN, DEVELOPMENT AND DISTRIBUTION - Simon Fraser , Victoria University of Wellington
RESEARCHER-INDUSTRY PARTNERSHIP TO ENABLE INNOVATIVE PROCESSES: A CASE STUDY - Pauline Calloch , Callaghan Innovation	WHAT IS INDUSTRY 4.0? DISPELLING THE COMMON MYTHS AND FEARS - Yuqian Lu , The University of Auckland	DESIGNING AND 3D PRINTING A 25 KG STAINLESS STEEL BUILDING STRUCTURAL NODE - Mike Fry , TIDA
MARKET SHAPING FOR DEEP-TECH INNOVATION - Julia Fehrer , Business School, The University of Auckland	APPLICATION OF AUGMENTED REALITY AND INDUSTRIAL INTERNET OF THINGS TECHNOLOGIES TO HIGH VALUE MANUFACTURING PROCESSES - Kevin Maret , LEAP Australia	OPTIMISED 3D PRINTED STRUCTURES: DEVELOPING A SIX-AXIS ROBOTIC SPATIAL PRINTING SYSTEM - Hamish Morgan , Victoria University of Wellington
CAN YOU TEACH ENTREPRENEURSHIP TO UNDERGRADUATE ENGINEERS? - Nick Pickering , University of Waikato	MĀORI GEOMETRY AND INDIGENOUS COMPUTATIONAL DESIGN - A CASE STUDY FOR 3D PRINTED STRUCTURES - Derek Kawiti , Victoria University of Wellington	A HYBRID ADDITIVE MANUFACTURING STRATEGY FOR INJECTION MOULD INSERTS - Simon Chan , The University of Auckland
THE FORM AND FUNCTION OF INTERMEDIARIES IN A SCIENCE AND TECHNOLOGY CONTEXT - Paul Woodfield , Auckland University of Technology	A PRACTICAL JOURNEY INTO INDUSTRY 4.0 - Paul Gravatt , Motion Design	ADDITIVE MANUFACTURING WITH FLAME RETARDANT MATERIALS - Sarat Singamneni , Auckland University of Technology
RESEARCH AND DEVELOPMENT FUNDING OPPORTUNITIES VIA THE REGIONAL BUSINESS PARTNER NETWORK - David Claridge , ATEED	TAILORING INSPECTION TO APPLICATION – A DOUBLE EDGED SWORD - Rachael Tighe , University of Waikato	UTILISING PARAMETRIC CUSTOMISATION TO TRANSLATE AUXETIC STRUCTURE THEORY INTO ADDITIVELY MANUFACTURED MULTIMATERIAL PERFORMATIVE GEOMETRIES - Brittany Mark , Victoria University of Wellington
LEADTIME QUOTATION AND PRICING FOR MAKE-TO-ORDER MANUFACTURING SYSTEMS - Tava Olsen , The University of Auckland	SELF-SERVICE SILO – CUSTOMER CONVENIENCE 24/7 - Caleb Millen , Beckhoff Automation NZ, and Nikk King , NZ Controls	USING THE RIGHT TOOL FOR THE RIGHT JOB - Juan Schutte , CDAM Lab, The University of Auckland
DEVELOPING ENGINEERING DESIGN AND MANUFACTURING TALENT THROUGH THE FORMULA:SAE COMPETITION - Lizzy Grant , Department of Mechanical Engineering, The University of Auckland	APPLICATION OF RFID SENSORS IN DETECTION OF ILLICIT CONNECTIONS, SURFACE FLOWRATES, AND SEWER BLOCKAGES - Sundra Rami Reddy Tatiparthi , The University of Auckland	HIGH STRENGTH ALUMINIUM ALLOY LASER POWDER BED FUSION - Zhan Chen , Auckland University of Technology

12.30pm LUNCH: (GREAT ROOM 1) - SPONSORED BY FISHER & PAYKEL HEALTHCARE
 EXHIBITION VIEWING

1.30pm KEYNOTE SPEAKER: GREAT ROOM 4

David Chuter (CEO and Managing Director, Innovative Manufacturing Cooperative Research Centre, Australia)
ANZ MANUFACTURING - LEADERSHIP IN UNCERTAIN TIMES
Session Chair: Professor Jim Johnston (MaDE2020 Co-Chair, Victoria University of Wellington)

2.00pm CONCURRENT CONFERENCE SESSION 2		
GREAT ROOM 2	GREAT ROOM 3	GREAT ROOM 4
INNOVATION IN MANUFACTURING, DESIGN AND ENTREPRENEURSHIP Session Co-chairs: Jim Johnston and Bill Trompetter	NZ AND THE CIRCULAR ECONOMY Session Co-chairs: Oliver McDermott and Ben McGuinness	ORAL PRESENTATION (PRE-RECORDED) AND PANEL DISCUSSION 1 Session Co-chair: Associate Professor Mark Battley
ENHANCING GEOTHERMAL ENERGY RECOVERY AND FACILITATING ENVIRONMENTAL REMEDIATION THROUGH A NEW NANOSTRUCTURED CALCIUM SILICATE TECHNOLOGY - Jim Johnston, Victoria University of Wellington	BEYOND THE CIRCULAR ECONOMY WITH THE SUSTAINABLE DEVELOPMENT GOALS – MOVING ON FROM EFFICIENT TO EFFECTIVE - Barbara Nebel, thinkstep-anz	DIGITALISING MATERIALS INSPECTION: PROCESS CONTROL AND QUALITY ASSURANCE USING SMART IN-MOULD SENSORS - Andrew Gillen, Netzsch Australia Pty Ltd (Pre-recorded presentation)
INVESTIGATION OF NEW ZEALAND'S NATURAL MAGNETIC MINERALS FOR APPLICATION IN INROAD CHARGING SYSTEMS - Bill Trompetter, GNS Science	AIR-CRAFTED ARTEFACTS: ADDITIVE UPCYCLING PLASTICS WITHIN THE AVIATION TOURISM INDUSTRY - Courtney Naismith, Victoria University of Wellington	PANEL DISCUSSION 1 TOPIC: HOW CAN WE DEVELOP OUR MADE STUDENTS TO BE INDUSTRY READY? ADJUDICATOR: Mark Battley – Associate Professor (Engineering Science); Associate Dean Research, Faculty of Engineering; IMM Programme Lead - The University of Auckland PANELLISTS: <ul style="list-style-type: none"> • Allen Guinibert – R&D Collaboration Manager, Product Development, Fisher & Paykel Appliances • Mike Fry – CEO, Titanium Industry Development Association (TiDA) • Rahul Jangali – Doctoral Assistant (Engineering) , University of Waikato • Simon Fraser – Professor, School of Design Innovation, Victoria University of Wellington • Tava Olsen – Professor and Deputy Dean, Faculty of Business and Economics, The University of Auckland
DESIGN: IT'S ALL IN THE DETAILS - Alistair Patterson, Blender Design Ltd	LIFE CYCLE THINKING IN PRODUCT DESIGN - Oliver McDermott, Blender Design Ltd	
MODELLING AND OPTIMISING THE FLOW PROFILE OF A GAS VALVE - John Riley, Fisher & Paykel Appliances Ltd	3D PRINTING RENEWABLE MATERIALS - Marie-joo Le Guen, Scion	
DICHROIC COLOUR-CHANGING MATERIALS - Emma Wrigglesworth, Victoria University of Wellington	THE USE OF LIFE CYCLE ASSESSMENT IN EARLY DESIGN TO OPTIMISE THE ENVIRONMENTAL PERFORMANCE OF ACTIVE PRODUCT SYSTEMS - Mike Horrell, Massey University	
NEW ZEALAND FIRMS: REACHING FOR THE FRONTIER - Geoff Lewis and Jo Smith, New Zealand Productivity Commission	DEVELOPMENT OF A BUILDING-INTEGRATED PHOTOVOLTAIC PRODUCT FOR LONG RUN METAL ROOFING - Benjamin McGuinness, University of Waikato	
3.30pm AFTERNOON TEA: (GREAT ROOM 1) POSTER AND EXHIBITION VIEWING (POSTER PRESENTERS TO BE AVAILABLE AT THEIR POSTERS FOR VIEWING AND JUDGING)		
4.00pm CONCURRENT CONFERENCE SESSION 3		
GREAT ROOM 2	GREAT ROOM 3	GREAT ROOM 4
4D PRINTING Session Co-chairs: Tim Miller and John McDonald-Wharry	DESIGN FOR MEDICAL APPLICATIONS Session Co-chairs: Lorenzo Garcia and George Stilwell	INNOVATION IN MANUFACTURING, DESIGN AND ENTREPRENEURSHIP Session Co-chairs: Paul Ewart and Jérôme Leveneur
A DESIGN-SCIENCE COLLABORATION: TAILORING BIO-MATERIALS AND 4D PRINTING FOR NEW PRODUCT OPPORTUNITIES - Tim Miller, Victoria University of Wellington	DESIGN OF A NOVEL STENT FOR HAEMORRHAGE CONTROL - Lorenzo Garcia, Auckland University of Technology	SURFACE ENGINEERING BY TITANIUM PARTICULATE INJECTION MOULDING - Paul Ewart, Waikato Institute of Technology
POLYMERS FOR 4D PRINTING - Patrick Imrie, The University of Auckland	DESIGN AND MANUFACTURE OF A PATIENT HANDLING SYSTEM FOR A NOVEL UPRIGHT MRI SYSTEM - Christy Wells, School of Design, Victoria University of Wellington	DESIGN AND DEVELOPMENT OF AN APPLE FRUITLET THINNING END-EFFECTOR - Rahul Jangali, University of Waikato
ADDITIVE MANUFACTURING WITH RESPONSIVE COMPOSITE MATERIALS AND BIOBASED POLYMERS - John McDonald-Wharry, University of Waikato	DEVELOPMENTS AND OPPORTUNITIES IN MEDICAL TEXTILES - Nimesh Kankariya, Centre for Materials Science and Technology, University of Otago	A REVIEW OF THE MOST RECENT DEVELOPMENT IN ADHESIVELY BONDED JOINTS FOR METAL/COMPOSITE STRUCTURAL FRAMEWORKS - Ardeshir Saniee, Auckland University of Technology

	NEW OPPORTUNITIES FOR MICROFABRICATION - Andrea Bubendorfer , Callaghan Innovation	DESIGN AND DEVELOPMENT OF A QUICK RELEASE ARM BRACE FOR A PARALYMPIC CYCLIST - George Stilwell , University of Canterbury	SURFACE MODIFICATIONS AND COATINGS FOR IMPROVED ENERGY EFFICIENCY AND PERFORMANCE - Jérôme Leveueur , GNS Science
5.00pm	NO ACTIVITY PLANNED		
5.30pm	Student Innovation Showcase (Happy Hour) - sponsored by the University of Waikato		
6.00pm	Pre-dinner drinks		
7.00pm	CONFERENCE DINNER (GREAT ROOM 4) - SPONSORED BY BECKHOFF AUTOMATION LTD Dinner Welcome: Professor Jim Johnston (MaDE2020 Co-Chair, Victoria University of Wellington) Key Dinner Address: Brett O'Riley (CEO, Employers and Manufacturers Association)		

Tuesday 8 Decembr 2020

8.30am	REGISTRATION OPENS		
9.15am	INTRODUCTION OF DAY: GREAT ROOM 4 Session Chair: Professor Jim Johnston (MaDE2020 Co-Chair, Victoria University of Wellington)		
9.30am	KEYNOTE SPEAKER: GREAT ROOM 4 Rebecca Percasky (CEO, The Better Packaging Co.) THE BETTER PACKAGING CO. FOR A ZERO WASTE WORLD Session Chair: Professor Jim Johnston (MaDE2020 Co-Chair, Victoria University of Wellington)		
10.00am	MORNING TEA: (GREAT ROOM 1) - SPONSORED BY MINISTRY OF BUSINESS, INNOVATION AND EMPLOYMENT POSTER AND EXHIBITION VIEWING (POSTER PRESENTERS TO BE AVAILABLE AT THEIR POSTERS FOR VIEWING AND JUDGING)		
10.30am	CONCURRENT CONFERENCE SESSION 4		
	GREAT ROOM 2	GREAT ROOM 3	GREAT ROOM 4
	INNOVATION IN MATERIALS MANUFACTURING AND DYNAMICS Session Co-chairs: Nicholas Emerson and Kariappa Maletira Karumbaiah	ADDITIVE MANUFACTURING APPLICATIONS Session Co-chairs: Muhammad Asif Ali Rahmani and Josh Barnett	ORAL PRESENTATION (PRE-RECORDED) AND PANEL DISCUSSION 2 Session Co-chair: Professor Simon Bickerton
	SCALING-UP: COMMERCIALISING OUR SCIENCE - Nigel Sharplin , Infact Limited	COMPLIANT GRIPPERS - AN ADDITIVE APPROACH - Josh Barnett , University of Waikato	POTENTIAL ENERGY STORAGE IN NEW ZEALAND - Alex Slocum , Massachusetts Institute of Technology (Pre-recorded presentation)
	EFFECT OF CNC MACHINING ON PERCEIVED TACTILE PROPERTIES OF NATIVE AND NON-NATIVE TIMBERS - Nicholas Emerson , University of Canterbury	DEVELOPMENT OF HTV SILICONE WITHIN NEW ZEALAND - Charlotte Bunnett , New Zealand Artificial Limb Service	PANEL DISCUSSION 2 TOPIC: SUSTAINABILITY AND THE CIRCULAR ECONOMY - WHAT DOES IT MEAN FOR MADE?
	FATIGUE BEHAVIOUR OF CARBON-FIBRE EPOXY COMPOSITES WITH RESIN FLOW CHANNELS - Kariappa Maletira Karumbaiah , The University of Auckland	HIGH RESOLUTION ELECTROHYDRODYNAMIC PRINTING FOR FLEXIBLE ELECTRONICS AND SENSOR FABRICATION - Muhammad Asif Ali Rahmani , Massey University	ADJUDICATOR: Simon Bickerton - Professor (Mechanical Engineering), Faculty of Engineering; Director (Centre for Advanced Composite Materials) - The University of Auckland PANELLISTS: • Derek Kawiti - Senior Lecturer (Digital Design Communication), Victoria University of Wellington • Florian Graichen - GM, Forest to Biobased Products, Scion • Harry Burkhardt - Chair, Ngāti Kuri Trust Board Incorporated; MD, Replas Ltd • Kim Pickering - Professor and Associate Dean Research (Engineering), University of Waikato • Rebecca Percasky - CEO, The Better Packaging Co.; MaDE2020 Keynote Speaker
	FABRICS AS SENSORS: EFFECTS OF EXTERNAL FACTORS ON PERFORMANCE - Sophie Wilson , University of Otago	FABRICATION AND CHARACTERISATION OF 3D PRINTED MICROCHANNELS - Swapna Jaywant , Massey University	
	EFFECT OF YARN ARRANGEMENT IN FABRIC ON WATER TRANSFER FROM WET TEXTILE TO VITRO-SKIN® - Sahar Abdolmaleki , University of Otago	THERMAL 3D SCREEN PRINTING OF SACRIFICIAL WAX MOULDS - Hossein Najaf Zadeh , University of Canterbury	
	PLANAR TO WHIRLING - A RESONANT ENERGY TRANSFER PHENOMENA EXHIBITED IN LEN LYE'S KINETIC ART - Angus McGregor , University of Canterbury	THE DESIGN FOR ADDITIVE MANUFACTURING OF COMPLIANT MECHANISMS FOR APPLICATION IN THE AVIATION INDUSTRY - Ishaan Singhal , The University of Auckland	

12.00pm	LUNCH (GREAT ROOM 1) - SPONSORED BY FISHER & PAYKEL APPLIANCES EXHIBITION VIEWING		
1.00pm	CONCURRENT CONFERENCE SESSION 5		
	GREAT ROOM 2	GREAT ROOM 3	GREAT ROOM 4
	APPLICATION-BASED ADDITIVE MANUFACTURING Session Co-chairs: Conan Fee and Jonathan Stringer	APPLICATION-BASED DESIGN Session Co-chairs: Euan Coutts and Digby Symons	INNOVATION IN A NZ CONTEXT Session Co-chairs: Lizanne Gomes and Stefan Korber
	3D-PRINTED MONOLITHIC POROUS STRUCTURES FOR BIOLOGICAL SEPARATIONS - Conan Fee, School of Product Design, University of Canterbury	MEASUREMENT OF DIAL FEEL ON APPLIANCES - Stephen Gibson, Fisher & Paykel Appliances Ltd	ENGINEERING AND MARKETING COLLABORATION AT THE FRONT END OF INNOVATION: A CASE STUDY OF A MEDICAL DEVICE COMPANY - Lizanne Gomes, The University of Auckland
	APPLICATION OF ADDITIVE MANUFACTURING FOR RAPID PRODUCT DEVELOPMENT – A CASE STUDY - Arno Ferreira, DFAM Lab, The University of Auckland	THE EXPERIENCE OF PROTOTYPING FOR DESIGN STUDENTS IN A DISTRIBUTED WORLD - Euan Coutts, University of Canterbury	KIWI INNOVATION ON THE WORLD STAGE - Ben Thomsen, Blender Design Ltd
	ENERGY ABSORPTION OF FUSED DEPOSITION MODELLING (FDM) 3D PRINTED TRIPLY PERIODIC MINIMAL SURFACES (TPMS) STRUCTURES - Ben Murton, University of Canterbury	DESIGN OF A TANDEM RACING BICYCLE - Digby Symons, University of Canterbury	FINDINGS FROM OVER 40 NZ MANUFACTURER INNOVATION DIAGNOSTIC SURVEYS - Adrian Packer, IMS-projects
	INKJET PRINTING: ADDING VALUE TO TRADITIONAL MANUFACTURING - Jonathan Stringer, The University of Auckland	DEVELOPMENT OF A NON-DESTRUCTIVE TESTING TOOL FOR INSULATED PIPE INSPECTION - Joseph Bailey, Victoria University of Wellington	WHEN AN ELEPHANT WALKS INTO A ROOM FULL OF ENGINEERS: DISJOINTED INTERPRETATION OF INNOVATION IN ENGINEERING FIRMS - Stefan Korber, The University of Auckland
2.00pm	CONCURRENT PANEL DISCUSSION SESSION 2		
	GREAT ROOM 4		
	TOPIC: HOW SHOULD MADE BE DIFFERENT FOR NEW ZEALAND POST-PANDEMIC?		
	ADJUDICATOR: Olaf Diegel – Professor (Additive Manufacturing), Faculty of Engineering; Director, Creative Design and Additive Manufacturing Lab; MaDE Network Leader - The University of Auckland		
	PANELLISTS: • Brett O'Riley - Chief Executive, Employer and Manufacturers Association • Catherine Beard – Executive Director: ManufacturingNZ, ExportNZ, BusinessNZ • Johan Potgieter – Professor (Robotics and Automation), Massey Agrifood Digital lab; Director, Massey University Centre for Additive Manufacturing • Oliver McDermott – Founding Partner, Blender Design Ltd • Rod Oram – International Business Journalist, Author and Celebrity Speaker (Entrepreneurship and Innovation)		
3.15pm	AWARDS AND CONFERENCE CLOSING - SPONSORED BY GNS SCIENCE & PDMA-NZ Session Co-Chairs: Olaf Diegel and Jim Johnston		
4.00pm	POST-CONFERENCE COCKTAILS - SPONSORED BY UNIVERSITY OF CANTERBURY		

Poster Presentations

02. Innovation, design, product development and manufacturing in a green, energy efficient environment	ATV TYRE ROLLING RESISTANCE IN AGRICULTURE - Tim Petterson, University of Canterbury
	DEVELOPMENT OF INNOVATIVE CROSS-DISCIPLINARY ENGINEERING SHOWCASE - Jai Khanna, Waikato Institute of Technology
	AUTOMATED BANDSAWN PLYWOOD CLADDING PRIME AND PAINT MACHINE - Mohammad Al-Rawi, CEID/Waikato Institute of Technology
	GLASS-REINFORCED EPOXY LAMINATE ELECTRODES FOR SENSING APPLICATIONS - Kartikay Lal, Massey University
04. Additive Manufacturing – including specialist products and mass customisation	FOSSILS FROM THE FUTURE - Jessica Salter, School of Design, Victoria University of Wellington
	CONTINUOUS, HIGH SPEED RESIN 3D PRINTING BY INTERFACE TEMPERATURE CONTROL - Jason Collingwood, Massey University
	IN-SITU LOW POWER LASER RE-MELTING OF DIRECT METAL PRINTED SPECIMENS FOR IMPROVED SURFACE FINISH - Tanisha Pereira, Massey University
	TOPOLOGY OPTIMIZATION AND GENERATIVE DESIGN OF PRODUCTS UTILIZING SELECTIVE LASER MELTING - Daniel Song, The University of Auckland

04. Additive Manufacturing – including specialist products and mass customisation	DESIGN AND TOPOLOGY OPTIMIZATION OF AN AUTONOMOUS DRIVING SHUTTLE BODY FOR ADDITIVE MANUFACTURING - Benedictus Notoprodjo, Massey University
	MANUFACTURING HYBRID COMPOSITE PARTS USING 3D PRINTED CONTINUOUS FIBRE REINFORCED POLYMERS - Hamed Abdoli, The University of Auckland
	HIGH PERFORMANCE CONTINUOUS FIBRE COMPOSITE 3D PRINTING: A PROCESS SCIENCE-BASED APPROACH - Joshua Hares, The University of Auckland
05. Advanced and functional materials in product design and manufacturing including additive manufacturing	NOVEL POLYMER MATERIAL FOR WIRELESS IMPLANTABLE SENSORS - Simon Blue, University of Canterbury
	MICRO-CONTACT PRINTED, SELF-ASSEMBLED PATTERN-BASED ARSENIC DETECTION - Swapna Jaywant, Massey University
	INFLUENCES OF AMBIENT TEMPERATURE ON SINTERING OF BIODEGRADABLE POLYLACTIC ACID (PLA) USED IN FUSED DEPOSITION MODELLING (FDM) - Adel Ameer, University of Waikato
	CHARACTERISATION OF THE RELATIONSHIP BETWEEN HYDROGEL PROPERTIES AND 3D-PRINTING PARAMETERS - Melissa Ishii, University of Canterbury
	PROTEIN-BASED BIOMATERIALS FOR 3D & 4D PRINTING - Heiana Agnieray, The University of Auckland
	ASSESSING THE DESIGN OF BONE INTERFACING ADDITIVE MANUFACTURED TITANIUM MEDICAL DEVICES VIA IMAGING - Kenzie Baer, University of Otago, Christchurch
	ELECTROSPINNING OF PROTEIN NANOFIBERS - Qun Chen, The University of Auckland
	DEVELOPMENT OF A SHEEP KNEE FINITE ELEMENT MODEL TO OPTIMISE THE DESIGN OF ADDITIVE MANUFACTURED IMPLANTS - Josephine Shum, University of Otago, Christchurch
	ADHESIVELY BONDED METAL-COMPOSITE STRUCTURES FOR AIRCRAFT INTERIOR APPLICATIONS - Shuo Xu, Auckland University of Technology

07. Industry 4.0 and Data Driven Design and Innovation	A SMART MONITORING PLATFORM FOR MACHINERY HEALTH MANAGEMENT IN THE FRAMEWORK OF INDUSTRY 4.0 - Madhurjya Dev Choudhury, The University of Auckland
	AUGMENTED REALITY-ENABLED MACHINE MAINTENANCE FOR CYBER-PHYSICAL MACHINE TOOLS - Zexuan Zhu, The University of Auckland
	RETROFITTING STRATEGY OF MANUFACTURING SYSTEMS TO INDUSTRY 4.0 STANDARD - Dylan Luther Malvar, Auckland University of Technology
	INNOVATING IN THE AGE OF AI, AN EXPLORATION OF HUMAN-AI COOPERATION IN INTERNATIONAL BUSINESS - Jitao Yan, The University of Auckland
	DEVELOPMENT OF AN OPERATION MANAGEMENT SYSTEM (CP-OMS) FOR SMART FACTORIES - Reza Hamzeh, The University of Auckland
	COMPLEX DESIGNER: PHYSICAL INTERACTION AND IMMERSIVE VISUALISATION WITH VIRTUAL PRODUCTS - Annabelle Ritchie, University of Canterbury
	RECONDITIONING FESTO MANUFACTURING MACHINES FOR USE WITH ROCKWELL AUTOMATION EQUIPMENT - Praneel Chand, Waikato Institute of Technology
08. Digital tools for manufacturing, automation and control including robotics and automation	
15. Human Capability Development	HUMAN CAPITAL 4.0: COMPETENCES AND SKILLS FOR DISRUPTIVE CHALLENGES - Emmanuel Flores, The University of Auckland
16. Other	MINIMISING CONSTRUCTION AND DEMOLITION WASTE TO ADVOCATE SUSTAINABLE CONSTRUCTION IN RESIDENTIAL BUILDING PROJECTS - Rohit Gade, Auckland University of Technology

First Name	Last Name	TEI/Organisation	Email	Short Title
Alasdair	Campbell	University of Waikato	alibo.chur@gmail.com	Development in sheep/ goat milking cups
Madhurjya	Choudhury	The University of Auckland	mcho491@aucklanduni.ac.nz	A Data-based Diagnostic Platform for Machinery Health Management
Jason	Collingwood	Massey University	jasoncollingwood1@gmail.com	Continuous, high speed resin 3D printing by interface temperature control
Catherine	Downes	University of Waikato	catherine_endownes@outlook.com	Maaratech Platform
Scott	Harvey	University of Waikato	scottlive@hotmail.co.nz	Automated Vine Pruning End Effector
Sam	Hewlett	University of Waikato	samohew@gmail.com	3D Printer Waste Recovery
Rahul	Jangali	University of Waikato	rjangali@waikato.ac.nz	Development of an Apple Fruitlet Thinning Robot
Sana	Khan Azmi	AUT	nendosana@hotmail.com	Pediatric Laparoscopic Instrument (Prototype)
Izaak	Knegt	Massey University	izaak.knegt@gmail.com	Portable Hand Sanitiser Dispenser
Sam	Knox	University of Waikato	sam.knox@hotmail.co.nz	3D Printer Waste Recovery
Taniela	Lolohea	The University of Auckland	tlol728@aucklanduni.ac.nz	Atmospheric plasma jet printing: controlled and tailored thin films
Dylan Luther	Malvar	AUT	dl_malvar1995@yahoo.com.ph	Retrofitting Strategy of Manufacturing System to Industry 4.0 Standard
Vincent	McQueen	Victoria University of Wellington	mcqueenvincent@gmail.com	DfAM: A Conceptual Monitor Arm for Air NZ
Thomas	Milliken	University of Canterbury	thomas.milliken@pg.canterbury.ac.nz	Low-cost Fabrication of Periodically Structured Titanium Parts from Recycled Ti64
Hamish	Morgan	Victoria University of Wellington	hamish.morgan@vuw.ac.nz	Optimised 3D Printed Structures
Courtney	Naismith	Victoria University of Wellington	courtney.jade.naismith@gmail.com	Air-Crafted Artefacts
Matthew	O'Hagan	Victoria University of Wellington	matt.e.ohagan@gmail.com	From Line to Loop. A Circular 3D-Printing Initiative for Up-cycling Commercial Fishing Plastic
Tanisha	Pereira	Massey University	t.pereira@massey.ac.nz	In-Situ Machine-Learning digital and thermal camera vision for an inerted Direct Metal Printer

Rehmani	Muhammad Asif Ali	Massey University	m.a.a.rehmani@massey.ac.nz	High resolution conductive printing on curved surfaces
John	Riley	Fisher & Paykel Appliances	john.riley@fisherpaykel.com	Modelling and Optimising the Flow Profile of a Gas Valve
Annabelle	Ritchie	University of Canterbury	annabelleritchie42@gmail.com	COMFlex Designer
Ardeshir	Saniee	AUT	ardeshir.saniee@aut.ac.nz	Cost-effective fibre reinforced polymer composite-metal joint structural frameworks
Ayesha	Shaukat	Massey University	A.Shaukat@massey.ac.nz	A portable multi-modal micro-imaging system for automated scanning
Sheau Lan (Alicia)	Sim	University of Waikato	sheaulansim@gmail.com	Rock Melon Harvester
Nathan	Vockerodt	Massey University	nmvockerodt@gmail.com	Automation of 3D printing
Shuo	Xu	AUT	shuomk23@gmail.com	Demonstrator of Adhesive-bonded Metal-Composite Structure for Aircraft Interior Component

MaDE2020 Panel Discussions

MaDE 2020 Panel Discussion Programme

Mon 7 December

2.15 - 3.30pm 1. How can we develop our MaDE students to be industry ready?

Tue 8 December

10.45am - 12.00pm 2. Sustainability and the Circular Economy - what does it mean for MaDE?

Tue 8 December

2.00 - 3.15pm 3. How should MaDE be different for New Zealand post-pandemic?

There will be three Panel Discussions, one on the afternoon of Monday 7 December, one on the morning of Tuesday 8 December and the third on the afternoon of Tuesday 8 December. Each Panel Discussion will be adjudicated by a senior MaDE researcher from the University of Auckland.

OVERALL AIM OF THE PANEL DISCUSSIONS:

To identify opportunities, challenges and strategies related to each topic so as to enable New Zealand's MaDE economy to retain and expand its global competitiveness.

THE PROCEEDINGS:

- The Adjudicator introduces the topic and Panel members. This should not take more than five minutes.
- Panellists introduce their insight into the topic for about three minutes each followed by an open discussion.
- Delegates will be invited to contribute to the discussions from the floor.
- All Panel Discussions will be recorded.

RECAP OF THE SESSION AT THE CLOSING CEREMONY:

The outcomes and findings of the Panel Discussions will be summarised by the Adjudicators for presenting succinctly in the Closing Ceremony and in more detail for the post-MaDE2020 Conference Report.

MaDE Panel Discussion Topics

PANEL 1:

How can we develop our MaDE students to be industry ready?

Monday 7 December, 2.15 - 3.30pm | Venue: Great Room 4

ADJUDICATOR:

Mark Battley Associate Professor (Engineering Science); Associate Dean Research, Faculty of Engineering; IMM Programme Lead - The University of Auckland

PANELLISTS:

- **Allen Guinibert** - R&D Collaboration Manager, Product Development, Fisher & Paykel Appliances
- **Mike Fry** - CEO, Titanium Industry Development Association (TiDA)
- **Rahul Jangali** - Doctoral Assistant, University of Waikato
- **Simon Fraser** - Professor, School of Design Innovation, Victoria University of Wellington
- **Tava Olsen** - Professor and Deputy Dean, Faculty of Business and Economics, The University of Auckland

INTENDED OUTCOME:

A well-educated and adaptable workforce is crucial to New Zealand having a successful MaDE industry. Currently each of the Manufacturing, Design and Entrepreneurship disciplines is typically taught separately, and there is a lack of integration across different parts of the education sector, often with limited connectivity between education providers and industry.

This panel will identify and discuss possible approaches and strategies that could be used to strengthen the MaDE workforce through a holistic approach to their education. We are interested to hear views and ideas from education providers, industry, and recent graduates.



FISHER & PAYKEL

Panel Discussions continued

PANEL 2:

Sustainability and the Circular Economy - what does it mean for MaDE?

Tuesday 8 December, 10.45am – 12.00pm | Venue: Great Room 4

ADJUDICATOR:

Simon Bickerton Professor (Mechanical Engineering), Faculty of Engineering; Director (Centre for Advanced Composite Materials) - The University of Auckland

PANELLISTS:

- **Derek Kawiti** – Senior Lecturer (Digital Design Communication), School of Architecture, Victoria University of Wellington
- **Florian Graichen** – GM, Forest to Biobased Products, Scion
- **Harry Burkhardt** – Chair, Ngāti Kuri Trust Board Incorporated; MD, Replas Ltd
- **Kim Pickering** – Professor and Associate Dean Research (Engineering), University of Waikato
- **Rebecca Percasky** – CEO, The Better Packaging Co.; MaDE2020 Keynote Speaker

INTENDED OUTCOME:

Establishment of a circular economy provides a prime opportunity for the merging of manufacturing, design and entrepreneurship. The broad concept of sustainability is evolving, but spans environmental, cultural, social, and economic dimensions. Within the context of MaDE, there is a need to address existing waste streams, develop carbon neutral manufacturing processes, as well as to design new materials and products that take into account product end-of-life. Technical advances in these fields, along with new marketing strategies and business models, can equip New Zealand industry with the tools to succeed in a circular economy.

This panel will be an opportunity for industry and research providers across the MaDE disciplines to come together for a discussion on the creation of a sustainable future. It will be a forum for sharing of opinions, and experiences with sustainable technology and business developments, also to debate the critical needs of industry that should be addressed by the MaDE Network.



PANEL 3:

How should MaDE be different for New Zealand post-pandemic?

Tuesday 8 December, 2.00 – 3.15pm | Venue: Great Room 4

ADJUDICATOR:

Olaf Diegel Professor (Additive Manufacturing), Faculty of Engineering; Director, Creative Design and Additive Manufacturing Lab; MaDE Network Leader - The University of Auckland

PANELLISTS:

- **Brett O'Riley** – Chief Executive, Employer and Manufacturers Association
- **Catherine Beard** – Executive Director: ManufacturingNZ, ExportNZ, BusinessNZ
- **Johan Potgieter** – Professor (Robotics and Automation), Massey Agrifood Digital lab; Director, Massey University Centre for Additive Manufacturing
- **Oliver McDermott** – Founding Partner, Blender Design Ltd
- **Rod Oram** – International Business Journalist, Author and Celebrity Speaker (Entrepreneurship and Innovation)

INTENDED OUTCOME:

MaDE, in the wider sense, is about an integrated approach to manufacturing, design and entrepreneurship, centred around advanced technologies, in order to add true value to New Zealand businesses. MaDE, if applied for good reasons and in a suitable way, promises multiplied value and leads to better and more sustainable products and processes. However, for New Zealand companies that still rely on silo-based disciplines, many challenges exist in the 'Why', 'How' and 'When' to engage with integrated MaDE.

This Panel will discuss both what should be unique about MaDE for New Zealand in order to suit the characteristics of new New Zealand enterprises, as well as how MaDE can be used to generate new and value-added business opportunities for New Zealand. The panel will debate the challenges from both a business and an applied research perspective.

R&D TAX INCENTIVE

What if your business could achieve more through R&D?

Invest in research and development and your business may qualify for a new 15% tax credit, helping to reduce your income tax bill.

Find out if you are eligible for the R&D Tax Incentive (RDTI) and how to enrol – visit www.rdti.govt.nz

Student Innovation Showcase

Sponsored by the University of Waikato
Happy Hour: Let's all talk together – students, industry and academics
Mon 7 December 5.30 – 7.00pm | Venue: Pre-function space

This Pop-up exhibition provides students with the opportunity to explain their work through physical demonstrations, samples or exhibits; and also to strike up conversations with and gain feedback from industry, academics and fellow student delegates at MaDE2020.

It will be a show-and-tell form of conversational presentation, with delegates mingling freely in the conference exhibition area. Students whose Expressions of Interest have been accepted for this session will be bringing their demonstration/sample/exhibit (e.g. 3D print/object, etc.) to MaDE2020 and setting up in the designated exhibition area. Exhibits will be on display in the allocated demonstration space only for the session time.

There will be a single BEST Innovation Showcase Prize valued at \$1,000 (including \$500 cash and 3D printing credits to the value of \$500) and three Highly Commended Prizes valued at \$300 each (including \$150 cash and 3D printing credits to the value of \$150). 3D printing will be done at the University of Auckland's Creative Design and Additive Manufacturing Lab. All prizes will be announced during the MaDE2020 Closing Ceremony on Tuesday 8 December 2020.

Please note, all delegates are invited to cast a vote to help determine the BEST and Highly Commended Innovation Showcase prizes. The success of this event requires your participation and as a thanks, a spot prize for voting will be given to a lucky delegate. This prize will also be announced during the MaDE2020 Closing Ceremony on Tuesday 8 December 2020.

THE FULL LIST OF STUDENTS PRESENTING, INCLUDING CONTACT DETAILS, CAN BE FOUND ON PAGES 18-19



MaDE2020 Prizes and Awards

The MaDE2020 Conference Committee is pleased to be offering the following awards and prizes which will be presented during the closing proceedings on Tuesday 8 December 2020, 3.15-4.00pm:

Award/Prize	Sponsor	Value (\$)
People's Choice Award Best Oral Presentation	GNS Science and PDMA-NZ	500.00
Poster Presentation First Prize	GNS Science	500.00
Poster Presentation Second Prize		300.00
Poster Presentation Third Prize		200.00
Student Innovation Showcase First Prize	University of Waikato & The University of Auckland's Creative Design and Additive Manufacturing Lab (3D Printing Credits)	1,000.00 (incl. \$500 cash)
Student Innovation Showcase 3x Highly Commended Prizes		300.00 (incl. \$150 cash)
Student Innovation Showcase Voting Spot Prize for lucky delegate	MaDE2020 Conference Committee	60.00

Delegate Feedback (Lucky Draw Prize)

Lucky Draw Prize Delegate Feedback	MaDE2020 Conference Committee	500.00
---	-------------------------------	--------

Your post-event feedback is important to us.

Online feedback forms will be sent to all registered delegates immediately following MaDE2020.

To be eligible to win the Lucky Draw Prize of \$500 you should include your contact details and your feedback must be:

- Submitted by the stated deadline
- Complete and of an acceptable quality



Care to make a difference?
www.fphcare.com/careers

Fisher & Paykel
 HEALTHCARE

Key Presenters

MaDE in NZ - TURBO CHARGING EFFORTS FOR AN ECONOMIC RECOVERY



KEYNOTE ADDRESS: 9.30 - 10.00AM, MONDAY 7 DECEMBER

CATHERINE BEARD

Executive Director, Manufacturing NZ

BIO

Catherine Beard is Executive Director of Export NZ and Manufacturing NZ, divisions of Business NZ, New Zealand's largest business advocacy group, representing thousands of businesses of all sizes.

The Business NZ group includes four large regional business associations, the *Major Companies Group*, *Export NZ*, more than 70 affiliated industry associations and *Buy NZ Made*.

The group's goal is New Zealand's prosperity through successful business.

Catherine works with government and other key decision makers on issues of concern to exporters and manufacturers.

Catherine has spent the last 20 years as a lobbyist and advocate for a wide range of industries on a wide range of issues, including on climate change issues for the energy intensive sector, all aspects of the fire and general insurance sector and the agricultural sector (dairy focus). Catherine has participated in Prime Minister led trade missions to Indonesia and China and represents BusinessNZ at various international meetings.

Catherine was also a co-founder of a start-up business designing and manufacturing children's nursery furniture, for which two products won national design awards.

ANZ MANUFACTURING - LEADERSHIP IN UNCERTAIN TIMES



KEYNOTE ADDRESS: 1.30 - 2.00PM, MONDAY 7 DECEMBER

DAVID CHUTER

CEO and Managing Director, Innovative Manufacturing CRC

BIO

David Chuter is CEO and Managing Director at the Innovative Manufacturing CRC (IMCRC) (www.imcrc.org), based in Melbourne. David is an experienced senior executive with a strong industry record in leading strategic business growth, operational management and change in the manufacturing sector.

He is passionate about local industry and creating a stronger platform for Australian manufacturing through catalysing investment in technology, innovation, collaboration and competitiveness. David has more than thirty years of international manufacturing experience, with much of this gained in the global automotive industry.

David joined the IMCRC in June 2016. Prior to this, he was CEO of MHG Asia Pacific from 2014, and a member of the Futuris Automotive executive leadership team from 2001.

David is a member of Australia's Industry 4.0 Advanced Manufacturing Forum, responsible for the research and innovation and digital business models workstreams. He is a Director of the CRC Association and a Member of the Australian Institute of Company Directors.

David holds a first-class Honours Degree in Manufacturing Engineering and Management from the University of Bath (UK), and is a Chartered Engineer with the Institution of Engineering and Technology.



GALA DINNER SPEAKER: MONDAY 7 DECEMBER

BRETT O'RILEY

CEO, Employers & Manufacturers Association

BIO

Brett O'Riley is the Chief Executive of the EMA, having commenced in that role in January 2019. He is a graduate of Victoria University of Wellington, with post graduate qualifications from MIT (Boston) and Singularity University (San Jose).

Brett returned to New Zealand from Australia in 2009 and has spent the last 10 years dedicated to the goal of growing the New Zealand innovation eco-system, as founding CE of NZICT, founding deputy CE of the Ministry of Science+Innovation,

and recently as Chief Executive of ATEED, Auckland's economic growth agency until September 2017. Prior to that Brett worked in the telecommunications and IT sectors for 20 years in New Zealand and internationally.

Prior to joining the EMA Brett worked as a Director and Advisor to organisations with a common goal, connecting them with international markets and opportunities. Brett will continue to be involved with some of these including directorships of Dotterel Technologies, Wine Grenade and the New Zealand Film Commission, and he also serves as the independent chair of the Hapi Brewing Success PGP project.

THE BETTER PACKAGING CO. FOR A ZERO WASTE WORLD



KEYNOTE ADDRESS: 9.30 - 10.00AM, TUESDAY 8 DECEMBER

REBECCA PERCASKY

CEO, The Better Packaging Co.

BIO

With a micro biology degree under her belt, Rebecca began her career working with multinationals (Vodafone, HP and IBM) to deliver complex tech implementations involving numerous moving parts including the management of people.

As COO of StarShipIT, Australasia's highest-rated eCommerce shipping software company, she was responsible for partnering with courier companies and expanding its market penetration.

Working so closely with the rapidly expanding eCommerce industry, Rebecca became cognisant of the growing repercussions for packaging waste. When researching alternatives to plastic, Rebecca was highly inspired to do packaging 'better'. That was the genesis of her collaboration with Kate Bezar and The Better Packaging Co. was established in March 2018.



CENTRE OF ADVANCED COMPOSITE MATERIALS

cacm.auckland.ac.nz

PLASTICS CENTRE OF EXCELLENCE

pcoe.org.nz

Polymers and composites are vital to many industries due to their versatility, though over time, new challenges have emerged: responsible design, sustainability, and how these fit into the circular economy.

Our centres engage expertise from the Engineering, Science and Medical faculties to perform transformative **Research**, **Educate** students at all levels, while enhancing New Zealand's companies through **Industry Engagement**.



AMS Advanced Manufacturing Solutions: Opening our doors to industry

AUT

- Testing, forensics & analysis
- Independent advice & expert opinion
- Design, prototyping & production pilots

=

Smart products,
next generation
processes

For further details, contact Andrew Hilton
andrew.hilton@aut.ac.nz



advanced material science

We're rethinking the future of energy. By developing more efficient processes and materials to increase manufacturing productivity, lower emissions, and harvest new sustainable energy resources,

GNS Science is designing the way forward.

gns.cri.nz



**WE PRODUCE
INDUSTRY
READY
GRADUATES**

 THE UNIVERSITY OF
WAIKATO
Te Whare Wānanga o Waikato

SCHOOL OF ENGINEERING
TE KURA PUKAHA

eng.waikato.ac.nz
07 838 4026

Designing research for impact

Presenting Author

Cleland, Don J.

Science for Technological Innovation (SfTI), Massey University
d.cleland@massey.ac.nz

MacDonell, Stephen G.

SfTI, AUT, University of Otago
stephen.macdonell@aut.ac.nz

McMath, Brian

NZ Product Accelerator
b.mcmath@auckland.ac.nz

Tronchin, Enrico

SfTI, Callaghan Innovation
enrico.tronchin@callaghaninnovation.govt.nz

There is increasing pressure from Government for tangible outcomes and impacts (economic, environmental, social or cultural) from their research investment. MBIE recently proposed the concept of a “line of sight to impact” based on a results-chain framework that links inputs, to activities, to outputs, to outcomes, and through to impacts. For some years, most Government-related research bidding processes have used a format consistent with this framework where the research programme is cast as a number of impact statements, each with research aims, critical steps and achievement measures. SfTI’s experience is that researchers use the format to present their research designs and plans in a very defensive manner: critical steps and achievement measures are often process-orientated, seemingly to secure funding continuity rather than have impact.

This paper provides guidance on how to design and present research plans that aim to create commercial potential for the science or technology being studied. Key components include:

- Early engagement with the relevant sector to define the science & technology gaps that could supercharge business performance; to understand the performance requirements of a proof of concept in order for businesses to invest in commercialisation; to move from a technology-push to a market-pull ethos
- Understanding competing science ideas & technology by going beyond the academic literature to consult non-academic information sources, especially patent literature and existing commercialised technologies
- Framing critical steps as significant outcomes (not outputs) that lead to impact.
- Using achievement measures that match the criteria for the next source of commercialisation development funding/investment.
- Defining possible options if targets are not met, with the philosophy of failing fast and using lessons gained to “pivot” towards a new opportunity.
- Deciding how potential IP will be assessed and, if appropriate, protected prior to publication.

Don Cleland is Professor of Process Engineering in the School of Food & Advanced Technology at Massey University and Theme Leader for Materials, Manufacturing Technology and Design in the SfTI. His research interests are industrial refrigeration, heat pumping, energy efficiency and food processing.

Researcher-Industry partnership to enable innovative processes: a case study.

Presenting Author

Calloch, Pauline

Callaghan Innovation
pauline.calloch@callaghaninnovation.govt.nz

Dahm, Karl

Callaghan Innovation
karl.dahm@@callaghaninnovation.govt.nz

Lecarpentier, Frédéric

Callaghan Innovation
frederic.lecarpentier@@callaghaninnovation.govt.nz

Callaghan Innovation’s role is to empower New Zealand innovators with the goal of building a better New Zealand. We aim to do this by connecting the innovation ecosystem, providing tailored technical solutions, developing innovators’ skills and capability, and providing grants co-funding. The Research and Technical Services at Callaghan Innovation are dedicated to solving difficult technical problems and help New Zealand’s businesses grow faster through research and development, and innovation.

In this paper, we will highlight the challenges faced when working with NZ companies, especially ambitious, high-paced, low-budget start-ups. Successful collaboration between industry and researcher requires a common understanding of the industry’s need as well as the constraints of research work. We will use our experience with NZ additive manufacturing (AM) start-ups as a case study for how this relationship develops during a project and – when successful – leads to positive project outcomes.

We will also describe the role of powder and feedstock properties on successful manufacture of complex parts and detail the importance of post-processing of the printed part to obtain the optimal properties.

This presentation sits in the context of powder-based manufacturing being the dominant process in the field of ceramics and its rapid expansion in metallurgy in the past few decades due to its importance in AM. AM technologies have opened potential applications that were previously unachievable. The success of powder-based manufacturing (both traditional and new) depends greatly on the nature and quality of the particles that make the powder. This is often a hidden part of the AM process because feedstocks are bought from suppliers with the requisite properties. However, to use materials not yet printable and create IP on materials and processes (rather than part design) extensive material science studies need to be conducted.

Pauline Calloch is a research scientist undertaking ceramic complex shaping and powder metallurgy projects, conducted in collaboration with a different range of companies: from small start-ups, university groups, to established SMEs. Pauline’s main focus is to utilise materials science techniques to bring new technologies to industrial scale production.

Market shaping for deep-tech innovation

Presenting Author
Fehrer, Julia A.
The University of Auckland Business School
j.fehrer@auckland.ac.nz

Jonas, Julia M.
Siemens Management Consulting
julia.m.jonas@gmail.com

Storbacka, Kaj
The University of Auckland Business School
k.storbacka@auckland.ac.nz

Nenonen, Suvi
The University of Auckland Business School
s.nenonen@auckland.ac.nz

Brodie, Roderick J.
The University of Auckland Business School
r.brodie@auckland.ac.nz

For deep technological innovations markets are largely absent. This is because deep-tech (e.g., biotechnology, AI, robotics, advanced materials, blockchains, quantum computing, etc.), while having great potential to significantly impact our economy and society, also take a long time to reach market-ready maturity. Current research on the commercialization of deep-tech innovation often take traditional neoclassical views of markets-as-given. This is problematic, since markets for deep-tech form dynamically during and together with their technological progress. With this project we challenge the dominant neoclassical view of markets and instead introduce a new market shaping approach to develop strategic pathways for the commercialization of deep-tech innovation.

We suggest to rethink markets by viewing them as dynamic and malleable systems formed of subsystems that include multiple types of market participants (such as, funders, incubators, potential partners, potential customers, competitors, universities, etc.), each of which is active in one or more subsystems and so on. With this project, we aim to understand under which conditions specific subsystems, namely entrepreneurial innovation ecosystems work as market shaping institutions for deep-tech innovation. We analysed two embedded case studies – displaying each a New Zealand and the North Bavarian entrepreneurial innovation ecosystem, including three deep-tech startups per ecosystem.

To understand the complex nature of both entrepreneurial innovation ecosystems, we mapped networks of influential participants and examined ties on dyadic - and system-level. Particularly interesting seems the dyadic relationship between the visionary founding team and their mentors. On a system-level, systemic learning appears to be one central condition for shaping markets for deep-tech innovations. As a central contribution, we develop a strategic framework for entrepreneurs, managers, investors and public policy makers to assess dynamically the critical conditions for market shaping in the context of deep-tech innovation as an alternative to traditional static market potential assessment frameworks.

Julia A. Fehrer is Senior Lecturer in Digital Marketing at the University of Auckland Business School. Her research interest is systemic innovation in the context of deep-tech, sustainability and digital transformation. She has twelve years of professional experience with senior roles in strategy development and digital marketing across countries.

Can you teach entrepreneurship to undergraduate engineers?

Presenting Author
Pickering, Nick
University of Waikato
nick.pickering@waikato.ac.nz

Schlothauer, Ralf
University of Waikato
ralf-christian.schlothauer@waikato.ac.nz

Kovalsky, Peter
University of Waikato
peter.kovalsky@waikato.ac.nz

Engineers are often be seen as the group of people you hand your smart idea over to for manufacture and delivery, then cross your fingers and hope they do not ruin it. As engineers, we often fuel this stereotype by not stepping outside of our specialist box. At the University of Waikato, we believe that engineers, with a little training in creativity and business, can start their journey to becoming talented entrepreneurs. To test this belief, we sourced over 20 diverse real world problems from leading Waikato and Bay of Plenty businesses, organised a group of 180 second year students into small groups, taught them Systems Thinking, Design Thinking, Lean Canvas, Project Management, Investment Analysis, Request For Proposal (RFP) and business case writing, then watched the magic happen. There was a steep learning curve for students, but the results demonstrated a solid understanding of the need for innovation that is viable, feasible and desirable. The sponsor companies involved in the “dragons den” felt there were a few potential start-ups, while students gained an insight into the importance of, and challenges with, customer centricity, commercial modelling and project management. Most importantly, the result was a cohort of engineers who no longer fear what many originally assumed was the black art of business and entrepreneurship, a view that will hopefully benefit them throughout their careers.



Nick Pickering is a passionate technology leader & educator at the University of Waikato, who thrives on solving complex problems using a systems approach. Nick's career spans 20 years of international industrial experience within Avionics, Finance, Logistics & Manufacturing. Current research interests include Agritech, Smart cities, IoT & Digital Twins.

The form and function of intermediaries in a science and technology context

Presenting Author
 Woodfield, Paul
Auckland University of Technology
paul.woodfield@aut.ac.nz

Ruckstuhl, Katharina
University of Otago
katharina.ruckstuhl@otago.ac.nz

There is little research on the function of intermediaries in an innovation context. An intermediary – go-between, connector, broker, ‘matchmaker’, or mediator – bridges knowledge gaps. Typically, intermediaries in innovation are involved in forging agreement between parties, knowledge brokering, or enabling other organisations to innovate such as technology-transfer offices, incubators and research centres.

We explore the types of intermediaries found in a research and development (R&D) rich context, distinguishing between internal and external intermediaries, their function, and whether they are formal or informal intermediary roles. We employ a qualitative case study approach within the context of the New Zealand Science for Technological Innovation (SfTI) National Science Challenge. Specifically, we study a robotics and an additive manufacturing research team, with further data from around 300 researchers from nearly 40 organisations. These organisations include industry, Crown Research Institutes, multiple universities, and Māori stakeholders.

Preliminary findings suggested that intermediaries perform different functions within, between, and outside the science and technology teams. Intermediaries tended to be gateways or gatekeepers of knowledge flows between individuals, teams, or stakeholders. With a better understanding of their function, at what crucial points intermediaries need to be introduced, and whether they are formal or informal, we can potentially minimise uncertainty and redundancy in the innovation process and prompt action in the form of processes or interventions. Insight into the way knowledge is managed through intermediaries can help us understand what kind of relationships they have within teams/organisations, their value in the innovation process and research translation, and if they are a positive gateway, or an impediment to knowledge flow within science teams.

After a decade traversing the property industry in consulting, contractor, and engineering roles, Paul Woodfield is now in the department of International Business, Strategy, and Entrepreneurship at AUT. He is also part of the National Science Challenge: Science for Technological Innovation, investigating “Building New Zealand’s Innovation Capacity”.

Research and development funding opportunities via the regional business partner network

Claridge, David
 ATEED
David.claridge@aucklandnz.com

To progress an idea towards commercialisation, there are useful channels for funding the necessary Research and Development. These channels also help build credibility and the value proposition for follow-on funding and capital raising.

Beyond R&D funding available from within a university or its TTO, there is R&D funding available for students and projects via Callaghan Innovation (accessed via the NZTE Regional Business Partner “RBP” network -the Auckland RBP is ATEED). This funding is available for early stage ideas through to established businesses.

Callaghan Innovation R&D funding for undergraduates and post graduates into companies is 100% government funded. R&D funding for projects is 40% co-funded. (There is also R&D co-funding available via industry bodies and via the IRD R&D Tax Incentive -these are not covered here.)

Your local RBP (present throughout New Zealand) can help you access R&D funding, upskilling in Innovation Skills (via Callaghan Innovation) and upskilling in Business Growth (via NZTE Management Capability Development Fund co-funding). We find of most value can be connecting tech companies with others at a similar stage of business growth, with specialist expertise and into industry.

I obtained funding for 49 R&D projects in YE June 2020, with Total Project Cost of \$5.5M (attracting Government funding of \$2.5M). I have three RBP colleagues in Auckland helping R&D ventures and there are twenty of us across New Zealand.

Commercialisations this year included: an automated sign language avatar; anti money-laundering software; a hemp-seed spread; and boots using novel, sustainable materials. Mainly I’m working with digital and mechanical innovations.

David Claridge is a Business and Innovation Advisor with Auckland’s Economic Development Agency ATEED, working with inventors and technology ventures/companies to commercialise their ideas. As NZTE RBP, this includes accessing resources from Callaghan Innovation, industry and academia. Industries David has worked in include Engineering Services, IT, Telecommunications, Marine and Manufacturing.

Leadtime quotation and pricing for make-to-order manufacturing systems

Presenting Author
Olsen, Tava
The University of Auckland Business School
t.olsen@auckland.ac.nz

This talk gives an overview of my research in leadtime-based pricing. We consider a make-to-order manufacturer (e.g., custom furniture) whose customers are time sensitive. At the time of ordering customers will be presented with a menu of leadtimes and prices, just as companies like Amazon do for delivery times. However, since the manufacturer is capacity constrained these leadtimes need to reflect what can actually be manufactured (and when). Particular aspects considered are: non-linear waiting cost curves, heterogeneous customers, and quotes that affect customer satisfaction.

To be more specific, consider a local custom furniture manufacturer who offers a range of styles to customers. Customers browse the store until they find a style they like. They then pick from a range of fabric samples within their price range. Pricing is usually standard for the style of furniture (e.g., the couch type) and the fabric. Most local manufacturers will also quote a flat leadtime, such as six weeks to the customer and operate their production on a first-come-first-serve basis. However, such a policy is missing the opportunity to make more revenue from customers who are leadtime sensitive. By giving customers the option to pay more to get their couch (or similar) faster, they can increase both revenue and customer satisfaction. While there will be some constraint on fabric availability time, beyond this, leadtimes are a function of the manufacturing backlog and capacity. The sequence of orders in the factory are entirely at the firm's discretion. This research considers sequencing and quotation as the firm's decision. The methodology of the work consists of various forms of stochastic modelling. However, we have also performed some behavioural experiments to get a better sense of the correct form for the cost of waiting relative to what is quoted.

Tava is the Deputy Dean of the University of Auckland's Faculty of Business and Economics Administration. Her research interests include supply chain management, pricing, and inventory control; stochastic models of production, service, and health systems; stochastic games and stochastic control.

Developing engineering design and manufacturing talent through the Formula:SAE competition

Presenting Author
Grant, Lizzy
The University of Auckland
lizzy.grant@fsae.co.nz

Allen, Tom
The University of Auckland (Faculty of Engineering)
tom.allen@auckland.ac.nz

The success and sustainability of the New Zealand's design and manufacturing ecosystem is underpinned by the supply of young talent coming into the workforce and their ability to actively contribute upon graduation. The University of Auckland's Formula SAE team is producing graduates with a profile and skill sets that exceed those expected of traditional engineering graduates. This comes from the in-depth real-world learning experiences the team members are exposed to during their involvement in the design and build of their open-wheeled single-seater electric race car. A focus on quality engineering design within the team sees them ranked in the top 15 in the world out of over 200 teams.



Figure 1 The University of Auckland's 2019 Formula SAE race car

This presentation looks at the way the team functions; highlighting some key engineering challenges they regularly solve and their adoption of modern design and manufacturing processes to produce their competitive vehicle. These processes include the application of topology optimisation, additive manufacturing for metallic and polymer structures, composite laminate optimisation and VR-based vehicle simulators. The pathway to adoption of these processes will be discussed, as well as the direct benefits the team has seen as a result and how the possibilities these processes offer have influenced their approach to engineering design.

Lizzy Grant is a fifth-year undergraduate engineering and science conjoint student at the University of Auckland. Lizzy has been involved across a range of technical and management activities within the Formula SAE team, including as deputy team leader, team leader and electrical team co-leader.

IOT without Internet or Things

Presenting Author
Taore, Aryaman
Beckhoff Automation
a.taore@beckhoff.co.nz

Internet of Things is a modern-day gambit, but without compatible technology is more hype than reality. This presentation aims to tackle the challenges associated with implementing IOT on legacy hardware and covering cost-effective solutions tailored to the New Zealand market.

Instead of a proactive approach, industries are reactively adding on IOT sensors to their legacy hardware to bridge the gap. As all these systems talk to each other, and communicate the measurements or readings, they produce a tremendous amount of unstructured data. Instead, enabling existing PLC's with IOT connectivity and structuring data locally, which is inherently free, saves tremendous cost when connected to the cloud. Beckhoff's entire range of IOT enabled controllers and TwinCAT's simplicity to structure and share data to the cloud offers a cost-effective solution to modernise legacy hardware.

But industries can get even smarter by analysing data locally. Using cloud connectivity as simply a means of centralising data, but carrying out data analysis locally saves on cost, adds reliability and provides better real time action. TwinCAT analytics is a perfect example of an offline data crunching tool that outputs everything from productivity metrics to predicting repairs.

It has been difficult to justify the cost to deploy IOT in industry. But working on cost effective solutions that don't disrupt old setups can be NZ's first step towards industry 4.0.

Aryaman Taore is a recent engineering graduate from the University of Auckland and is currently completing his master's in optometry while working as a support engineer under Beckhoff. His masters and work at Beckhoff are focused around IOT and machine learning in the cloud.

What is Industry 4.0? Dispelling the common myths and fears

Presenting Author
Lu, Yuqian
The University of Auckland
yuqian.lu@auckland.ac.nz

Industry 4.0, originated as a German government initiative in 2011 and has taken a long journey to arrive in Aotearoa, New Zealand. In recent years, the flood of tailored marketing stories has shaped the understandings of Industry 4.0 in practice which, somehow, have derived away from its original vision. New Zealand needs to understand these confusions and embrace a localised Industry 4.0 destination and journey, driven by its unique manufacturing industry characteristics and global competitive niches.

In this presentation some common myths and fears around Industry 4.0 will be examined. In particular, the following questions will be answered, in the context of Aotearoa, New Zealand:

- What is Industry 4.0? What is not Industry 4.0?
- Is it relevant to you in reality? When does Industry 4.0 become relevant?
- What could an Industry 4.0 journey look like in New Zealand?

These reflections are based on the presenter's observation and participation in Industry 4.0 research and industry implementation in New Zealand and beyond.

Yuqian Lu is a Lecturer at The University of Auckland. His research interests span manufacturing automation, autonomous systems, industrial AI, and robotics. He is a strong advocate for translating fundamental and applied research into commercial adoption. He has led Industry 4.0 R&D successes in New Zealand.

Application of augmented reality and industrial internet of things technologies to high value manufacturing processes

Presenting Author
Marett, Kevin
LEAP Australia
kevin.marett@leapaust.com.au

Manufacturers are increasingly adopting Augmented Reality (AR) as a means to tackle the inefficiencies associated with traditional approaches to assembly processes, replacing static documentation and instructions with augmented digital overlays capable of delivering critical information in the context of the physical manufacturing environment as well as real-time sensor information. This presentation will give examples of how manufacturers are avoiding costly mistakes and prolonged downtime by leveraging AR to empower their workers, resulting in greater efficiency, reduced waste and increased first-time quality, ultimately improving overall operational efficiency.

Additionally, examples will demonstrate how the use of AR aligns with the Industrial Internet of Things (IIoT) to leverage machine and operational data to transform operational efficiencies and revitalize traditional manufacturing. Example of IIoT data being turned into actionable insights include visibility into real-time production line performance and status, unified connectivity of disparate assets and remote identification and resolution of potential issues ahead of time. Use cases from the recent IoT/AR Hackathon held at the University of Auckland will also provide a tangible demonstration of the business value that can be realized by SMEs embracing these disruptive technologies, with diverse examples from a range of industries across New Zealand.

Kevin Marett has worked for LEAP for over nine years, specialising in helping New Zealand manufacturing businesses to implement software solutions spanning design, engineering, manufacturing and service, in particular disruptive technologies such as PLM, Smart Connected Products & Smart Connected Operations.

Māori geometry and indigenous computational design - a case study for 3D printed structures

Presenting Author
Kawiti, Derek
Victoria University Wellington/CILOARC Architecture Ltd.
derek.kawiti@vuw.ac.nz

Gordine, Stacy
New Zealand Māori Arts & Crafts Institute
stacy@nzmaci.com

London, William
Kilwell Fibretube Ltd.
williaml@fibretube.co.nz



The upcoming installation of the Hemo rd. sculpture in Rotorua on the 20th of April this year will highlight two important aspects pertaining to our current industrial epoch: 1) The challenges facing a 'traditional' manufacturing industry/fabricator in its pivot or shift toward more large scale technologically demanding manufacturing, and 2) the drive/impetus for industry change due to an increase in design complexity redefining the limits of art, design, architecture and engineering.

The presentation will provide an overview of the design and fabrication process of arguably one of the largest 3d printed structures in the world in the last five years - currently in the final stages of fabrication by local manufacturer Kilwell Fibretube ltd. A range of issues will be discussed including the vast potential of Māori geometry and indigenous computational design (materialised through the sculpture) as a 'stretch' factor that could potentially drive development of much needed AEC and manufacturing industry capability.

While the use of 3D parametric and information modelling was critical to the project design during its early stages, the author argues a greater industry awareness and appreciation of the integrative power of the tools in both the AEC and manufacturing industry may have enabled higher efficiencies and mitigation of project risk.

Derek Renata Kawiti is a Senior Lecturer, Interdisciplinary Digital Design, director of multidisciplinary practice - *CILOARC*. Background in advanced parametric & procedural design methods, 'low' and 'high' tech' digital fabrication. Founder; open research lab - *SITUA* (Site of Indigenous Technologies Understanding Alliance). Collaborator. New Zealand Maori Arts and Crafts Institute of Te Puia, Rotorua. Research: New technical territories, indigenous hybrid fabrication practices, additive manufacturing and materials.

A practical journey into Industry 4.0

Presenting Author
Gravatt, Paul
Motion Design Ltd
paul@motiondesign.co.nz

Anderson, Gary
Motion Design Ltd
gary@motiondesign.co.nz

There is a wealth of information out there about what Industry 4.0 is, but how do you apply it to your business and how do you even get started? For many New Zealand companies, understanding the new jargon and unfamiliar technology can be a bit overwhelming.

However, there are ways to break down the transformation process into easily understandable steps. Changing your business incrementally is the best way to reduce risk, minimise capital outlay, remain agile and to manage your work culture.

“Think big, start small, scale fast” is a very appropriate mantra to follow. The first, and often hardest part, is thinking big. This is very strategic and requires vision, inspiration and leadership. Getting started requires taking a chance and being prepared to fail or iterate. This is a reason to start small.

Many Kiwi businesses are very manual and therefore in a position to skip a generation, right up to Industry 4.0. This is not achieved by simply adding a robot, but by making your robot smart, flexible and connected. Therefore, in addition to engineering skills, an automation partner will need to have strong analytical, software and integration skills.

This talk will explore some of the key practical steps you can take right now to start your transformation journey, complete with examples and common misconceptions.

Paul Gravatt is the Engineering Manager at Motion Design Ltd with over 10 years in automation, Paul started with Motion Design as a Design Engineer before moving into the Engineering Manager role. Paul is responsible for leading his manufacturing team through product development, design and build projects, and R&D. Paul holds a BE(Mech) with First Class Honours.

Tailoring inspection to application – a double edged sword

Presenting Author
Tighe, Rachael C.
University of Waikato
rachael.tighe@waikato.ac.nz

Vosper, Thomas
University of Waikato
tommyvoss46@gmail.com

Taylor, Cody J.
University of Waikato
codytaylor197@gmail.com

Hill, Jonathan G.
University of Waikato
jonnythehill@gmail.com

Tuhiwai, Tairongo Tio Pira
University of Waikato

Pulsed thermography is a non-destructive evaluation method that identifies subsurface defects by applying a thermal excitation to the specimen or component. As the heat propagates through the component, the surface thermal response is recorded using an infrared camera. Subsurface defects are identified due to differing thermal propagation in defective and defect-free regions. Typically, subsurface defects hinder the propagation of heat through the part and result in a hotspot directly over the defect. PT is a well-established near surface technique and is typically used for the inspection of thin panels. There are a range of variations of pulsed thermography within the literature. Some variants assess the use of differing thermal stimulus, i.e. changing the experimental approach, whereas some have looked at advancing signal processing approaches to dealing with the data collected.

Multiple variables, both experimental and processing can complicate the standardisation of an inspection approach as it puts more emphasis on the operator to select the appropriate parameters. However, inherent within that is a technique able to be tailored and optimised to a given application. The purpose of the presentation is to demonstrate, using a case study, the importance of optimising the inspection procedure for active thermography data collection and processing, and the impact of this optimisation on robust and reliable inspection.

Rachael Tighe is a Lecturer in Mechanical Engineering at the University of Waikato. Rachael's research area is in non-destructive testing and structural health monitoring with a specialisation on infrared and white light imaging-based techniques. Work focusses on extracting complimentary information from different techniques to provide a more complete assessment.

Self-service silo – customer convenience 24/7

Presenting Authors

King, Nikk
NZ Controls
nikk@nzcontrols.co.nz

Millen, Caleb
Beckhoff Automation NZ
c.millen@beckhoff.co.nz

A project for Ballance Agri-Nutrients was a self-service silo, involving traditional PLC controls and enterprise software integration without the need for complex middleware. The system effectively acts as a vending machine, where the customers and orders are verified in real time with Ballance's customised SAP ERP software.

To achieve this, NZ Controls uses a Beckhoff embedded PC running Windows 10 and TwinCAT 3 PC-based control. Using this controller, the best of both the IT/PC and OT/PLC worlds can be realised in a single package. At the same time the controller can directly interact with the business server, all the peripheral devices required such as RFID reader, barcode scanner, receipt printer and traditional PLC IO are able to be connected to and controlled by the controller via various fieldbus systems. The HMI server is also hosted directly on the controller.

To achieve the business connectivity, a secured connection to an SAP web service is used to exchange data directly between the controller and SAP. In the past multiple pieces of equipment would have been required to achieve this functionality and/or compromises would have been made.

This project has been very successful delivering a ruggedised industrial solution that has changed the way Ballance's customers access their products.

Nikk has a passion for engineering and found his niche with automation and controls. In 2004 he co-founded NZ Controls Ltd, now with over 35 staff delivering projects in NZ and globally. Nikk now applies his experience and knowledge to advise industry on how to use technology to maximise productivity.

As a Massey University Master of Engineering (Mechatronics) graduate, Caleb has worked in several industries, focusing on product development and automation. He is currently an Application Engineer encouraging others to take advantage of Beckhoff technology by providing training, demonstrations and product and application support.

Application of RFID sensors in detection of illicit connections, surface flowrates, and sewer blockages

Presenting Author
Tatiparthi, Sundra R. Reddy
The University of Auckland
Stat604@aucklanduni.ac.nz

De Costa, Yashika G.
The University of Auckland
ydec845@aucklanduni.ac.nz

Whittaker, Colin N.
The University of Auckland
c.whittaker@auckland.ac.

Zhong, Ray Y.
The University of Hong Kong
zhongzry@hku.hk

In many Organization for Economic Co-operation and Development (OECD) countries, water conservation efforts have led to a continuous decrease of inflows into sewer systems. Consequences resulting from the decreased inflows include decreasing average flow velocities and increased wastewater concentration. These phenomena have led to excess solid depositions in sewer pipes. Furthermore, combined with higher fat, oil and grease flushed into sewer pipes, the formation of "fatbergs" is inevitable, eventuating in blockages, sewer corrosion and odour issues. Blockages in pipes cause increased sewer overflows, which can pollute both aquatic and terrestrial environments.

Radio Frequency Identification (RFID) systems enable reliable, accurate and cost-effective methods for preventing and solving these issues happening in sewer pipes. We have been developing a suite of disposable and affordable RFID-based sensors in conjunction with the Internet of Things (IoT) for high-throughput detecting illicit connections and measuring flow velocities in sewer networks. RFID-based sensors showed enhanced sensing properties compared to conventional techniques such as smoke testing, dye testing, closed-circuit television camera (CCTV), and distributed temperature sensing (DTS). Field trials were conducted to find illicit household sewage connections to stormwater systems in the City of Auckland. In the trials, an illicit connection was found in a residential property, among 39 other properties tested, within three hours.

Furthermore, surface flow velocities measured from low (7 L/s) to high (70 L/s) flow conditions using RFID modules in open-channel flows were conducted. These predictions can be used to calculate blockages in special regions of pipes. The research has successfully shown the applicability of RFID-based sensors for underground asset management. It has also demonstrated that this system can be applied to extensive area networks and is appropriate for a broad spectrum of flow rates and weather conditions, which does not require access to private property than conventional methods.

Sundra R. Reddy Tatiparthi is a PhD candidate at the University of Auckland under the supervision of Drs Wei-Qin Zhuang, Ray Y. Zhong, and Colin N. Whittaker. Their research interests are in smart technology development and applications.

Democratising medical devices: 3D printing and open source systems for design, development and distribution

Presenting Author
 Fraser, Simon
Victoria University of Wellington, School of Design Innovation
simon.fraser@vuw.ac.nz

Gale, Jesse
University of Otago, Wellington
jesse.gale@gmail.com

Allen, Callum
Victoria University of Wellington
allencall@myvuw.ac.nz

Quilty, James
Victoria University of Wellington
james.quilty@vuw.ac.nz

Winton, Michael
Victoria University of Wellington
wintonmich1@ecs.vuw.ac.nz

Colenso, Hamish
Victoria University of Wellington
hamish.colenso@ecs.vuw.ac.nz

Increasingly, the open source movement has enabled users around the world to freely develop and distribute their own products. Initially, this approach was limited to software, however the continued improvement of 3D printing technologies, online file hosting platforms and e-commerce services has enabled the same model to be applied to the development of physical products as well.

From a medical perspective these developments are also particularly exciting, as commercially available medical equipment is often very expensive, limiting access to many practicing clinicians, particularly in developing countries.

This project documents the challenges and opportunities these emerging technologies provide in the design, development and distribution of a low cost, portable open source pupilometer in the form of a robust, ergonomic, binocular easy-to-assemble kit set. It is optimised for distributed additive manufacture and assembled with an open source electronic package (webcams, filters, LEDs, battery, Raspberry Pi) to form a fully contained and functional product, controlled by a laptop through a WiFi network.

The project was carried out by a multi-disciplinary team, comprised of electronic and computer systems engineers, clinicians and industrial designers. The design and development process called on low fidelity FDM printing for rapid prototyping, open forums for file sharing, component configuration and acquisition through online supply chains, DfAM and optimisation for distributed Additive Manufacture. While the immediate goal of the project was to develop the physical 'Openpupil' device, the broader intention is to use open-source technology to democratise interesting new clinical science. A cloud-based data collection system in the form of a Smartphone app would enable clinicians to collect, quantify and share their findings in an online biometric database, laying the foundations for a global online research community, which may eventually lead to enhanced diagnostic capabilities in a wide range of clinical settings.

Professor Simon Fraser has 35 years' experience in design research through a variety of roles; as Assistant Design Director at the Porsche Design Studio, Head of School and Associate Dean of Research & Innovation at the VUW School of Design Innovation and affiliations with the NZ Product Accelerator and the MedTech CoRE.

Designing and 3D printing a 25 kg stainless steel building structural node.

Presenting Author
 Fry, Mike
TiDA
mike.fry@tida.co.nz

Jackson, Ben
TiDA
Ben@tida.co.nz

3D printing allows great flexibility in design of physical parts. Historically 3D printing has been restricted to polymer components and smaller scale high-value metal items. Developments in Wire Arc Additive Manufacture (WAAM) have made practical and cost effective the 3D printing of large (1 to 250kg+) metal parts.

Combining the design freedom of 3D printing with large scale metal structural parts, WAAM offers a new range of possibilities for building, industry and sculpture projects.

This presentation will cover the design process and printing of a large structural node of a type that might be found in an architectural building. The design process was parametric, and algorithm driven to allow organic forms reflecting those found in nature. The part was printed using a novel spherical slicing system, adopted to conveniently build parts on a 2-axis rotary part manipulator. The result is a component that combines aesthetic values, mechanical performance, cost effectiveness and design flexibility not achievable by conventional means. The parametric approach allows "families" of nodes, each with custom variable connection points to be generated with a minimum of design effort. The ability to generate a structure with a large number of individually unique nodes allows great architectural design freedom to be a practical proposition.

The presentation will outline the design concept, design process, printing process, and manufacturing economics.

Mike Fry is CEO of TiDA, a company specialising in; Titanium, Powder Metallurgy and metal 3D printing. After a PhD at UCL, Mike worked at Lotus Cars, progressing to Chief R+D Engineer for Cosworth Technology in the UK. In NZ since 2007, Mike has 27 years of experience leading commercial R+D.

Optimised 3D printed structures: developing a six-axis robotic spatial printing system

Presenting Author
 Morgan, Hamish
 Victoria University of Wellington
 hamish.morgan@vuw.ac.nz

Miller, Tim
 Victoria University of Wellington
 tim.miller@vuw.ac.nz

Sweet, Kevin
 Victoria University of Wellington
 Kevin.Sweet@vuw.ac.nz

Spatial printing is a form of additive manufacturing where material, typically thermoplastic, is extruded directly in three-dimensional space producing non-layered structures. Spatial printing presents designers and engineers with a greatly improved level of control over material deposition, when compared to layer-based printing, resulting in economy in material usage and increases in print speed.

This study explores a method of generating spatially printed structures which are informed through finite element analysis. 3D topology optimisation is used to define an initial form which is converted into a spatially printable structure using a purpose-built algorithm. Structural analysis is performed to determine the concentration of stresses within the generated structure. The results of this analysis are used to control the density of individual elements within the structure.

An optimised chair structure was generated and robotically spatially printed to demonstrate the application of the spatial printing system. This application-based experiment shows how further economies can be gained by depositing material where structurally required. By combining topological optimisation systems and spatial 3D printing, strong and lightweight volumetric structures can be produced.

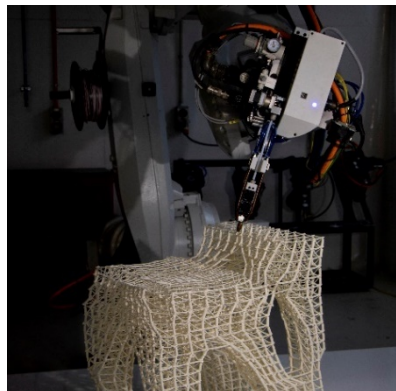

Hamish Morgan is the Robotic CNC specialist at Victoria University of Wellington. His area of research includes spatial 3D printing, finite element analysis, generative design and six-axis robotic fabrication. He is interested in how digital tools are changing the role designers' play in the field of design.

A hybrid additive manufacturing strategy for injection mould inserts

Presenting Author
 Chan, Simon
 Creative Design and Additive Manufacturing Lab (CDAM Lab), The University of Auckland
 ycha723@aucklanduni.ac.nz

Diegel, Olaf
 CDAM Lab, The University of Auckland
 olaf.diegel@auckland.ac.nz

Xu, Xun
 The University of Auckland
 xun.xu@auckland.ac.nz

Recent advances in metal additive manufacturing (AM) technology enable complex conformal cooling channels to be fabricated for injection mould inserts to enhance mould performance. However, limitations such as poor surface finish, low dimensional accuracy and high manufacturing costs hinder the technology to be adopted in the mould-making industry. In this study, a cost-effective hybrid-build strategy was developed for the fabrication of injection mould inserts. This method aims at reducing AM build and post-processing time. Supports-free base blocks, pre-machined with referencing features were used for the AM build and high-speed machining finishing processes. Four mould inserts, selected from an existing mould, were redesigned with conformal cooling channels and fabricated in a metal powder bed fusion system using the hybrid-build method. In comparison with the standard 3D printing practice with supports, a considerable time saving of about 25% was attained. Further testing of mechanical properties and examination of microstructure on cutup samples revealed excellent fusion between the powder-substrate interface. As a result, this new strategy can enhance mould performance at reduced manufacturing costs for the plastic products manufacturing industry.

Simon Chan is a PhD candidate within the Department of Mechanical Engineering at the University of Auckland. He has over 25 years of tool design and mould-making experience in New Zealand. His area of research interest is the application of additive manufacturing technology in injection moulds fabrication.

Additive manufacturing with flame retardant materials

Presenting Author
Singamneni, Sarat
Auckland University of Technology
sarat.singamneni@aut.ac.nz

Lv, Yi Fan
Auckland University of Technology
yifan.lv@aut.ac.nz

Thomas, Wayne; Chalk, Rodger; Hewitt, Andrew
Air New Zealand
wayne.thomas@airnz.co.nz; rodger.chalk@airnz.co.nz; andrew.hewitt@airnz.co.nz

Fire, within a confined space, surrounded by polymeric furnishings could be fatal. This makes it highly essential to find solutions based on fire retardant materials in particular, in applications such as aircraft and automobile interiors. The fire retardancy in polymers could be due to additives such as halogen or phosphorous based chemicals or based on the intrinsic material behaviour. The need to be eco-friendly, while also possessing the required mechanical and other properties often narrows the window of options drastically, but the limitations of the manufacturing processes further reduce the options available for fire-retardant product solutions. Bringing additive manufacturing into this already complex scenario makes it even more restrictive in terms of both materials and processing options. However, considering the other benefits common to additive approaches, more significantly, the design freedom and the just-in-time production options, evaluation of fire-retardant materials for additive manufacturing of aircraft interior products by different means becomes an important area of research.

The point-by-point and line-by-line consolidation mechanics seriously restricts the materials options, but the Nylon FR series, ULTEM series, PAEK, and PEEK have evolved as the promising options for processing by fused deposition modelling and selective laser sintering. While the material, process, and structure relationships are relatively less established, several other possibilities such as the nitrogen and metal-oxide based flame retardant options and the possibility to replace ULTEM by PAEK family polymers are not evaluated sufficiently. As part of a Callaghan innovation supported research done at AUT for Air New Zealand, the additive manufacturing options based on fire retardant material options have been reviewed thoroughly, apart from inventing some new solutions. This talk will dwell into some of the highlights, while also presenting a clear picture of the technology development and future possibilities with the additive manufacturing of fire-retardant materials.

Associate Professor Sarat Singamneni is at AUT and leading a team of researchers working on different aspects of additive manufacturing. The focus of the team is fundamental research in AM leading to process evaluation, enhancement, and development of materials alternatives, while also striving to help the wider uptake of the technology by the local industry.

Utilising parametric customisation to translate auxetic structure theory into additively manufactured multimaterial performative geometries

Presenting Author
Mark, Brittany
Victoria University of Wellington
brittanymark.77@gmail.com

Miller, Tim
Victoria University of Wellington
tim.miller@vuw.ac.nz

Auxetic Structures are a class of Metamaterials uniquely characterised by their Negative Poissons Ratio, that is when a lateral force is applied they expand longitudinally, becoming thicker and stronger, perpendicular to the strain. This counterintuitive behaviour has many enhanced behavioural properties, our research has specifically focused on their response to impact forces for sports protection scenarios.

Additive Manufacturing using the Stratasys J750 multimaterial printer allows us to print reactive physical properties of Auxetic Structures, manipulated through generative programming. This parametric customisation of the internal topology, materiality and subsequent 4D printing has the potential for geometries to be uniquely designed for pre-determined impact scenarios.

In order to achieve contextualisation a critical translation process is required. Auxetic theory classifies and describes structural geometry, mechanics and topological restrictions. Digitally CAD modelled geometries for tangible materials testing looks to bridge the gap between computer simulated predictions and physical outcomes of structures adapted through design means for fabrication. Understanding how similar or dissimilar tangible geometry behaviour is to theoretical expectations will allow for new, informed investigations into realistic opportunities for application implementation.

The majority of our focus is spent working in this translation space, parametrically modelling the structures three dimensionally and manufacturing prototyped samples to iteratively test and evaluate for their capabilities of producing the Auxetic effect under strain. Come the end of our research we hope to have used this process to identify structures more likely to succeed in a given context, one step closer to widely deploying Auxetic Structures for enhanced safety protection.

Brittany Mark is an Industrial Design Masters student at Victoria University of Wellington. She previously graduated with a Bachelor's degree in 2018. Following this she was a Summer Research Scholar with Callaghan Innovation, surveying Metamaterials, framing her current thesis: 'Translating Auxetic Theory into Parametric Structures for Additive Manufacturing'.

Using the right tool for the right job

Presenting Author

Schutte, Juan

*Creative Design and Additive Manufacturing Lab (CDAM Lab), The University of Auckland
juan.schutte@auckland.ac.nz*

Diegel, Olaf

*CDAM Lab, The University of Auckland
olaf.diegel@auckland.ac.nz*

Chan, Yuk Lun

*CDAM Lab, The University of Auckland
ycha723@aucklanduni.ac.nz*

Ferreira, Arno

*CDAM Lab, The University of Auckland
arno.ferreira@auckland.ac.nz*

In many cases today, rapid prototyping and additive manufacturing (AM, 3D printing) have become synonymous. Many companies and researchers use 3D printing because it exists, rather than because it is the most appropriate technology to use. This often results in an inefficient use of additive manufacturing.

The Creative Design and Additive Manufacturing Lab is home to a range of AM technologies that can print production parts in metal and in polymer. These tools are highly capable of manufacturing complex parts rapidly, however are not recommended as a means for producing geometrically simple shapes. This becomes increasingly apparent relative to part production time and cost. Understanding these manufacturing limitations, the Lab has also equipped itself with a range of 'conventional,' advanced manufacturing tools including CNC, laser cutting, waterjet cutting, etc. This allows the Lab to use the most appropriate technology to rapidly produce what is needed for rapid product development. But, to do this, understanding when to use which technology is essential.

To illustrate this, a case study involving the development of a 3D printing electrospinning system is described through which a set of metrics relating to production time and part morphology and fabrication techniques are identified as a potential guide for future rapid product development projects.

Juan Schutte holds a Research Fellow position at The University of Auckland and works within the Creative Design and Additive Manufacturing lab. He contributes to the development of 3D printing technology and aids in the supervision of multiple projects relating to 3D printer machine/mechanism development, prosthetics and tissue engineering.

High strength aluminium alloy laser powder bed fusion

Presenting Author

Chen, Zhan

*Department of Mechanical Engineering
Auckland University of Technology
zhan.chen@aut.ac.nz*

Chernyshova, Polina

*Department of Mechanical Engineering
Auckland University of Technology
pchernys@aut.ac.nz*

Singamneni, Sarat

*Department of Mechanical Engineering
Auckland University of Technology
sarat.singamneni@aut.ac.nz*

Hot cracking affects castability, fusion based weldability and thus fusion based metal 3D printability. For this reason, most high strength aluminium alloys are not castable, not fusion weldable and not fusion 3D printable. Similar to high pressure die cast (castable) alloys, the widely used 3D printing aluminium alloys are Al-(10-12)Si based alloys. As will be explained, the addition of a small amount of magnesium, at 0.3-0.7%, enables Al-Si alloys age hardenable, for example, for yield strength to reach 270MPa. In comparison, yield strength of high strength aluminium alloys ranges 350-500MPa. Thus, as will also be explained, various process and alloy development studies to improve 3D printability particularly of high strength aluminium alloys have been intensive in recent years. A proven 3D printable high strength aluminium alloy is the Al-4Mg alloy with a small addition of Sc and Zr, commercially called Scalmalloy.

It has been well demonstrated and we will also present that, using Scalmalloy, bimodal microstructures form during laser powder bed fusion 3D printing. The solidification sequence is equiaxed first and then columnar dendritic in each track thus not providing a condition for hot cracking to develop. We will show that yield strength of the 3D printed Scalmalloy by powder bed fusion in as-built state to be from 250MPa to over 300MPa, depending on printing condition. This can be explained by the dependence of the size and amount of Al₃(Sc,Zr) on the thermal history which varies due to printing condition variation. Similar to that already known in recent literature, we show that yield strength of the alloy after heat treatment can be higher than 450MPa. We will explain the treatment conditions for achieving optimal combination of strength and ductility (suggestive of toughness). Finally, our early study on fatigue behaviours of 3D printed Scalmalloy samples will be briefly discussed.

Zhan Chen is a materials engineer and a professor with the department of mechanical engineering at AUT. He currently is conducting research in the fields of metal additive manufacturing and friction stir welding. He teaches courses and supervises student projects and research on engineering materials and manufacturing technologies.

Enhancing geothermal energy recovery and facilitating environmental remediation through a new nanostructured calcium silicate technology

Presenting Author
Johnston, Jim

*School of Chemical and Physical Sciences
Victoria University of Wellington
jim.johnston@vuw.ac.nz*



Geothermal energy is a natural sustainable resource of heat energy which provides base load electricity generation from the steam and separated hot water phases. However the hot geothermal water is supersaturated in silica, which precipitates to form intractable silica sinter deposits in pipes, heat exchangers and reinjection wells. This is a major problem in geothermal resource utilisation worldwide. The sinter compromises heat energy recovery in binary cycle electricity generation, blocks pipes, heat exchangers and reinjection wells and increases maintenance. Current approaches attempt to address the problem by using higher steam/water separation temperatures to reduce silica saturation, or using acid dosing and additives to retard silica formation. However these are not satisfactory, silica still precipitates and the problem remains.

We have developed a new technology and are demonstrating it at pilot scale operation (see below). We rapidly react the supersaturated dissolved silica entities in the hot water with calcium ions to form a novel nanostructured calcium silicate material (CaSil), before the dissolved silica can deposit as the problematic sinter.

The CaSil particle surface chemistry is distinctly different from problematic silica. The CaSil particles do not accrete or deposit on metal surfaces or in reinjection wells. Silica sinter formation is eliminated, enabling more heat energy to be recovered from a geothermal resource and more electricity generated. Silica cannot now deposit in pipework, heat exchangers, or in reinjection wells.

The CaSil particles are recovered continuously. Their large-scale applications include:

- The capture of environmentally problematic phosphate and nitrogen species from dairy farm effluent and surface waters to form a “Green fertilizer” thereby recycling phosphate and nitrate species, and reducing their run-off to surface waterways.
- The capture of metals from industrial waste and mining streams.
- Lightweight, fireproof CaSil-cement-based building products.
- As a functional filler in rubber, plastics and paint to enhance their performance.

This paper presents an overview of this CaSil technology and product applications, notably in environmental remediation. New business opportunities are discussed.

Professor Jim Johnston has a Personal Chair in Chemistry at Victoria University of Wellington. He is a Principal Investigator in the NZ Product Accelerator co-chair of MaDE2020. His R&D is at the university-industry interface. He is recognised nationally and internationally for his research in new materials and chemical technologies and product developments.

Investigation of New Zealand's natural magnetic minerals for application in inroad charging systems

Presenting Author
Trompetter, Bill
*GNS Science
b.trompetter@gns.cri.nz*

Kim, Seho; Covic, Grant
*The University of Auckland
seho.kim@auckland.ac.nz;
ga.covic@auckland.ac.nz*

Leveueur, Jérôme; Turner, James;
Kennedy, John
*GNS Science
j.leveueur@gns.cri.nz;
j.turner@gns.cri.nz;
j.kennedy@gns.cri.nz*

Chong, Shen; Robinson, Fergus;
Long, Nick
*Victoria University of Wellington
s.chong@vuw.ac.nz;
fergus.robinson@vuw.ac.nz;
nicholas.long@vuw.ac.nz*

There has been a steadily increasing demand for magnetic materials in devices and charging systems over recent decades. The advent in the near future of in-road inductive power transfer (IPT) charging systems will massively increase this demand. Better, nonbrittle and affordable magnetic materials are required so that vehicles can run over charging pads built into the road without destroying them. This will require innovative solutions and new magnetic material sources to meet these needs in an economically viable way.

A potential way is using soft magnetic composite (SMC) materials which combine at least one magnetic filler within a matrix. While they usually exhibit lower magnetic permeability, they offer the flexibility to optimise their other properties by controlling the matrix composition including the magnetic filler composition and size distribution as well as the binder material. In this way, resulting SMC materials can be tailored to have better mechanical and thermal performance compared to other traditional SMC materials (such as ferrites or “magnetic concrete”). In addition, they often exhibit lower eddy current losses and higher efficiencies in their operating range.

In this project, we have scoped New Zealand's natural magnetic materials and their ability to be included as a viable magnetic material for our roads. We have investigated the magnetic permeabilities of NZ natural magnetic mineral deposits for such IPT application in roads. By integrating our findings with novel IPT systems and road designs, with optimisation of the magnetic, mechanical and thermal properties, we hope to deliver an effective solution for this emerging opportunity.

Bill Trompetter is a materials scientist at GNS Science, Gracefield, Lower Hutt. He has experience in ion beam analysis and other analytical methods. He has used these methods to investigate and study a wide range of materials including: air particulate matter, minerals, ceramics, thermal spray coatings, and more lately soft magnetic composite materials.

Design: it's all in the details

Presenting Author
Patterson, Alistair
Blender Design Ltd
Alistair@blender.net.nz

Creating a product that solves a real problem is a great start to product success, but this alone will only get you so far. The difference between a good product and a great one is all in the small details. If executed correctly these details may not be obvious, but collectively, they can completely transform the end result.

From the moment a customer lays eyes on your product they are interacting with it. Every detail matters: the shape and form, the materials used, the quality of the manufacturing. Every point of interaction is an opportunity to impact the user experience.

A bad user experience can kill a product and seriously damage a brand. A great user experience will make your product memorable.

Every product is different and requires a well thought out design process with the right team to execute properly. Perfecting the details can be tricky, however, the approach is often similar, design, test, and iterate to perfection.

In my presentation, I will share some examples of product design projects where the details made all the difference, and walk you through some of the methods and tools that we use to identify, design and perfect such details.



Originally graduating from Massey University with a Master's in Industrial Design, Alistair Patterson is a Senior Industrial Designer at Blender Design. Alistair Has Over 10 years of experience working in leading design consultancies creating a variety of award-winning and successful products.

Modelling and optimising the flow profile of a gas valve

Presenting Author
Riley, John
Fisher & Paykel Appliances
john.riley@fisherpaykel.com



Garby, Romain
Fisher & Paykel Appliances
romain.garby@fisherpaykel.com

Many gas burners do not have a linear decrease in power output when turning the temperature dial from high to low. This is due to the valves being designed universally, while they should be designed specifically for the burner they are to be used in.



In these systems, the flowrate of the gas is primarily controlled by the narrowest passage it must pass through, often the jet in the burner. The problem with many systems is that the flowrate through the valve is controlled by areas larger than that of the jet, resulting in most of the turn-down doing very little.

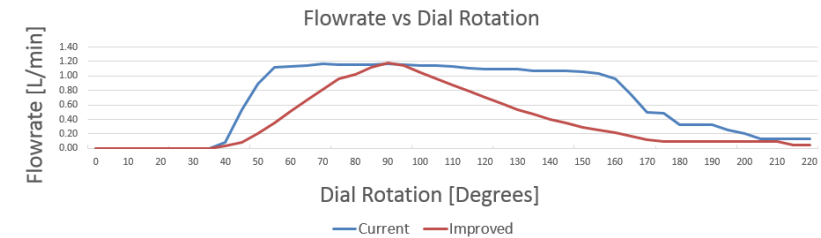

To remedy this, the valve should be designed specifically for the system it's used in. This can be done by altering the size and positions of the channels in the cone-shaped central piece of the valve. To make this efficient, a mathematical representation of the system was used to design the geometry of this cone based off the desired turn-down. The goal of this project is to create a model of the system such that in the future a 3D model of the cone could be automatically generated using the desired output and system conditions.

John Riley is a graduate production development engineer working at Fisher & Paykel Appliances in Dunedin as part of the customer cooking interfaces team. He graduated with an honours degree in mechanical engineering from the University of Auckland and is interested in the research and development of mechanical systems.

Dichroic colour-changing materials

Presenting Author
Wrigglesworth, Emma
Victoria University of Wellington
Emma.wrigglesworth@vuw.ac.nz

Johnston, Jim
Victoria University of Wellington
Jim.johnston@vuw.ac.nz

We present specially designed and synthesised nano/micro-particles that display an attractive dichroic effect; they appear one colour in transmitted light but a different colour in reflected light. As this effect is a unique property of the particles arising from their composition, structure and optical properties, it cannot be duplicated by other means. Hence dichroic nano/micro-particle composites are ideally suited for the design of non-copyable images and devices for security applications and product authentication to protect high-value NZ products.

Our work has successfully traced the origin of the dichroic effect in metallic gold nanoparticles. Theoretical analysis of the interaction between light and particles of different sizes and shapes has been achieved using Mie theory and has been used for comparison with experimental results to further investigate the nature of scattering and absorption processes in these systems. The relationship between the size, shape, and composition of the particles and the colours displayed has been deduced for this material.

Building upon this knowledge, we have extended the dichroic effect into nano- and micro-particles made of alternative, non-metallic materials which we have characterised in detail and studied theoretically. Optimisation of synthesis methodologies has resulted in the display of clean and bright dichroic colours. This further enhancement of our understanding of the features required to observe the effect has led to the production of a range of dichroic materials, producing a palette of different colours in reflected and transmitted light.

Upon the proprietary incorporation of metallic and non-metallic particles into selected polymers, the colours displayed in both reflected and transmitted light have been retained. This process has effectively encapsulated the dichroic effect in the solid state, allowing us to utilise the unique optical effect displayed by these composite materials in application.

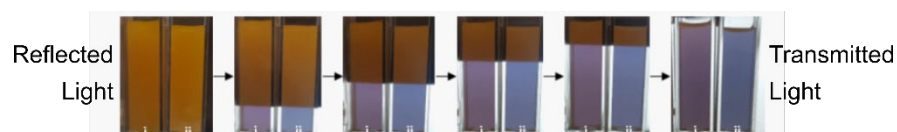

Emma Wrigglesworth is in the final stages of her PhD in Chemistry at Victoria University of Wellington. Her research is focused on the design and synthesis of nano- and micro-particles with unique optical properties, and their incorporation into polymers for application.

New Zealand firms: reaching for the frontier

Presenting Authors
Lewis, Geoff
New Zealand Productivity Commission
geoff.lewis@productivity.govt.nz

Smith, Jo
New Zealand Productivity Commission
joanna.smith@productivity.govt.nz

The Government has asked the Productivity Commission to conduct an inquiry into maximising the contribution of New Zealand's frontier firms. These firms play an important role in shaping overall productivity in the economy both through their own performance and through the way they diffuse new technologies and business practices to other New Zealand firms. The presentation will draw on the Commission's draft report with its draft findings and recommendations about the performance of New Zealand frontier firms compared to global frontier firms, the opportunities and barriers the firms face, and how government policies could improve outcomes. The inquiry has also examined Māori frontier firms. The Commission is receiving submissions on its draft report until the end of January 2021. It will deliver a final report by 31 March 2021 taking account of submissions received, further stakeholder engagement and its own further research.

Geoff Lewis is a Principal Advisor at the New Zealand Productivity Commission. An economist by training, he has led or played a leading role in many of the Commission's inquiries including Local Government Funding and Financing, New Zealand's Transition to a Low-emissions Economy, and Better Urban Planning. His broad interest is in boosting economic performance to enable greater social, economic and environmental wellbeing for New Zealanders.

Jo Smith is a Principal Advisor at the New Zealand Productivity Commission. She specialises in applied research and analysis to support data-informed decision making. Jo has spent much of her career as a consulting economist, undertaking mixed-methods research across the government, business and NGO sectors. In her time at the Commission, she has worked on the Local Government Funding and Financing inquiry, and now the Frontier Firms inquiry.

Beyond the Circular Economy with the Sustainable Development Goals – moving on from efficient to effective

Presenting Author

Nebel, Barbara

thinkstep-anz

barbara.nebel@thinkstep-anz.com

Responsible Consumption and Production is the core of the Circular Economy. It's also the theme Sustainable Development Goal (SDG) 12. However, there are 16 additional SDGs to consider too.

This presentation looks at wider reaching positive impacts of a true circular economy. Traditionally, a well implemented circular economy approach should help us to be more efficient in our resource and energy use. However, is a higher efficiency really what will help us to move on from doing less bad to doing more good? We might have to consider being more effective, rather than being more efficient...

Effective use of materials and energy can support progress to a number of different SDGs, including environmentally focussed aspects such as for example water use and climate change, but also social topics such as health and wellbeing or decent work and economic growth. In line with the vision of MaDE SDG 9 which represents "Industry, Innovation and Infrastructure" will be central to the analysis. The 17 SDGs have a total of 169 targets underneath them. Those targets help to unpack the high-level goals. The presentation will include a case study by the Steel Industry to showcase how the SDGs can be used to demonstrate the overall sustainability contribution of one sector beyond carbon.

Should the predictions that the global population reaches 9.6 billion by 2050 hold true we need to keep other sustainability challenges in mind be most effective in our decisions regarding material use.

Barbara Nebel's passion is to enable organisations to succeed sustainably. She often describes her job as a translator, translating sustainability into traditional business language. She and her team deliver a full range of sustainability services from strategy and materiality assessments through to Life Cycle Assessments and Cradle to Cradle® projects. Barbara is CEO of thinkstep-anz, the founder and first president of Life Cycle Association New Zealand (LCANZ) and on the Steering Group for the Climate Leaders Coalition.

Air-crafted artefacts: additive upcycling within the aviation tourism industry

Presenting Author

Naismith, Courtney

Victoria University of Wellington

courtney.jade.naismith@gmail.com

Fraser, Simon

Victoria University of Wellington

simon.fraser@vuw.ac.nz

Ok, Jeongbin

Victoria University of Wellington

jeongbin.ok@vuw.ac.nz

Within the New Zealand Aviation Tourism Industry (NZATI), an extensive amount of single-use plastic is consumed due to its light-weight properties and stringent hygiene requirements. After use, most end up in landfills causing immense environmental and health issues. Plastic waste can no longer be sent overseas, and New Zealand (NZ) still lacks sustainable waste management infrastructure. Moreover, there are limited recycling solutions for certain types of plastics, such as soft plastic. This poses a challenge for the industry, which generates tonnes of plastic waste and carbon emissions annually despite the implementation of sustainable practices.

This research presents an opportunity for industry leaders such as Air New Zealand to shift their current waste management model into a closed-loop system. The system focuses on how to upcycle inflight plastic through 3D printing (3DP) technologies into high-value products that reflect the identity of NZ. The research introduces how to implement 3D printed upcycling systems to benefit NZ culturally, economically and environmentally through several scenarios. A materials-led investigation with soft plastic bags, acrylonitrile-butadiene-styrene meal trays and polystyrene coffee stirrers revealed a variety of design possibilities. This resulted in a range of 3D printed artefacts with novel visual, tactile and structural qualities. These include baskets printed from soft plastic and flax filament, a large chandelier printed from coffee stirrers, and topographic tiles printed from in-flight meal trays combined with organic waste from the New Zealand Māori Arts and Crafts Institute.

The design outputs of this research act as a tangible reference for implementation by industry partners. Additionally, it demonstrates how 3DP and sustainable design approaches can be used to reduce environmental impacts and enhance product value. With a system of 3D printed upcycling in place, it provides the opportunity to promote sustainable tourism, allowing visitors to be responsible for their waste and encourage eco-conscious behaviours.

Courtney Naismith is enrolled in a Master's of Design Innovation degree at Victoria University of Wellington with Prof. Simon Fraser and Jeongbin Ok as her supervisor and co-supervisor respectively. Her research focuses on creative sustainability using upcycling and additive manufacturing technologies.

Lifecycle thinking in product design

Presenting Author
McDermott, Oliver
Blender Design Ltd
ollie@blender.nz

Sustainability is top of mind in 2020 and there is a huge demand for designers and manufacturers to respond with solutions that consider the full product lifecycle.

We've been taught how to create products that solve problems, meet user needs, and deliver profit to stakeholders. However, when it comes to creating products that are good for people and the planet, very little is known about how to actually do it.

Developing a truly sustainable product is a little more complicated than just putting it in a brown cardboard box. It requires a shift in thinking, looking through the life cycle lens. The more we do this, the better we'll get.

In my presentation, I will share our sustainable design journey and how we have researched and developed a sustainable product design framework. I'll show how we use this framework to help product owners understand their product lifecycle, leveraging this to develop successful new products that are better for everyone.

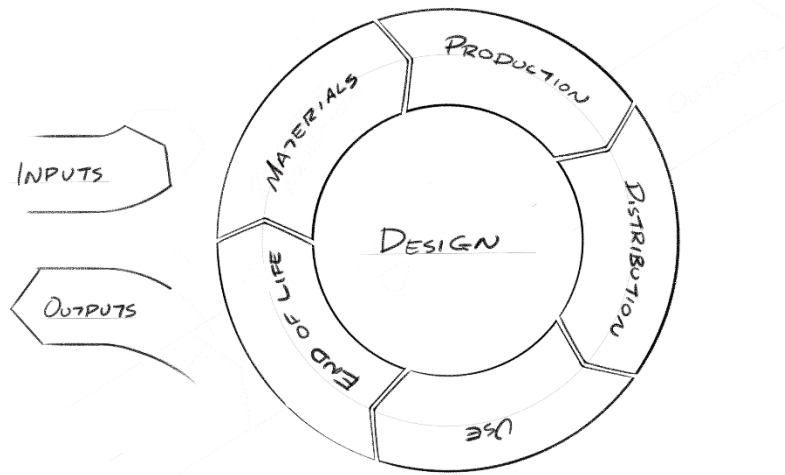

Oliver McDermott is a Founding Partner of Blender Design and Board Member of The Designers Institute of New Zealand. Oliver is a national design leader in looking for new and novel ways of designing and developing products and business models that deliver big positive impact.

3D printing renewable materials

Presenting Author
Le Guen, Marie-Joo
Scion
mariejoo.leguen@scionresearch.com

Zeidler, Henning
Technische Universität Bergakademie
henning.zeidler@imkf.tu-freiberg.de

Klemm, Diana
Beckmann-Institut
klemm@beckmann-institut.de

Singamneni, Sarat
Auckland University of Technology
sarat.singamneni@aut.ac.nz

The shift towards building a circular bioeconomy requires a holistic approach when manufacturing. In a NZ context, it makes additive manufacturing particularly attractive especially when done locally using renewable resources.

In this study, we investigate the utilisation of by-products biomasses from primary industries in additive manufacturing processes for custom packaging applications of sensitive components. Packaging of prototypes with sensitive or filigree structures or made of fragile materials is difficult and produces a lot of plastic waste as standardized packages are often not suitable.

Within this study, CAD-data based adapted packaging made of renewable raw materials is tested. The 3D-printing process was modified for using renewable lignocellulosic fibres and a water-based binder.

The manufactured packaging is conforming to the demands of packaging for fragile goods and can be produced just-in-time and locally. This application provides an attractive scenario for sustainable production and the re-or upcycling of local waste material such as wood flour seashell, or miscanthus fibres.

Marie-Joo Le Guen is a Research Leader for Additive Manufacturing at Crown Research Institute Scion. Her research interest is in biomaterials and their utilization in additive manufacturing processes. She has led MBIE grants and is currently involved in several international research collaborations, including a 2020 European Marie Skłodowska-Curie Action with INRA (Montpellier, France).

The use of Life Cycle Assessment in early design to optimise the environmental performance of active product systems

Presenting Author
Horrell, Mike
Massey University
m.horrell@massey.ac.nz

McLaren, Sarah
Massey University
s.mclaren@massey.ac.nz

Tunncliffe, Mark
Massey University
m.c.tunncliffe@massey.ac.nz

Manufacturers looking to reduce the environmental impacts of their products can apply state-of-the-art environmental assessment tools, such as Life Cycle Assessment (LCA), to assist design engineers in decision support. However, LCA is thought to be unsuitable for early design processes due to the limited information available about the product at that stage in the design process. A case study was undertaken to investigate the application of LCA when developing an active product system. The study followed the early development and optimisation of a water recirculation shower system and all related sub-systems (such as filtration systems and management of the incoming and outgoing water and energy) which is compared with a standard and heat recovery shower systems. The LCA results found the manufacture and maintenance of the additional subsystems required to recirculate wastewater was insignificant across most environmental impact categories. The energy required to heat water over the life of the system dominated the lifecycle-based impacts of all recovery systems modelled. Furthermore, the study found it necessary to include human-centred behavioural factors in the assessment and demonstrates how this will be an important consideration for studies of other active product systems. Overall, it was found that the use of LCA early in the design process is pivotal in providing engineers with environmental information so that informed eco-design decisions can be made for active product systems.

Mike Horrell is a PhD student and Product Development lecturer at Massey University. His research area of interest is eco-design and as a lecturer he teaches a variety of approaches to improve the environmental performance of products including Life Cycle Thinking and Circular Economy and more analytical tools such as Life Cycle Assessment.

Development of a building-integrated photovoltaic product for long run metal roofing

Presenting Author
McGuinness, Benjamin
University of Waikato
benjamin@waikato.ac.nz

Duke, Mike
University of Waikato
mike.duke@waikato.ac.nz

There is a need for New Zealand products to align with the concept of a circular economy and be designed and manufactured in an energy efficient environment. This case study outlines the development of an innovative building integrated photovoltaic (BIPV) product which produces renewable energy while also acting as a long-run roof.

Electricity generation in New Zealand is primarily from renewable sources (82%), however, there has been little support for our most abundant resource, solar, which accounts for less than 0.3% of total generation. Typical photovoltaic installations consist of bulky panels which are mounted to frames and bolted to roofs after construction. They are aesthetically poor, use materials inefficiently, heavy, and do not align with holistic building design. One potential solution is building integrated photovoltaics that function as both an electricity generator and a roof. New Zealand is in a good position to innovate in this area as it receives a fairly high level of solar radiation and has a small and agile roofing industry.

A BIPV concept was developed and a number of prototype panels were produced. Photovoltaic cells were laminated directly to a COLORSTEEL roofing substrate, using EVA as the encapsulant with a flexible ETFE polymer top sheet. The flat sheet was then folded in a CNC folder into a profile capable of mating with standard roofing profiles. This produced a fully integrated product which acted as both a building material and energy generator as pictured below.

This study showed that it is technically feasible to develop a green BIPV product that can be manufactured efficiently, however, the recycling facilities are not currently in place in NZ in order to produce a circular product.

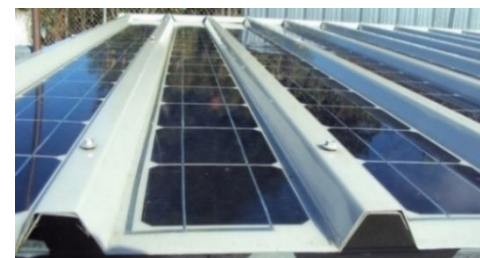

Benjamin McGuinness is a Post-Doctoral Researcher at the University of Waikato. His research interests include industry focused product development and automation in the agricultural sector.

A design-science collaboration: tailoring bio-materials and 4D printing for new product opportunities.

Presenting Author

Miller, Tim
Victoria University of Wellington
tim.miller@vuw.ac.nz

Fraser, Simon
Victoria University of Wellington
simon.fraser@vuw.ac.nz

Fu, Yejun
Victoria University of Wellington
junfj@gmail.com

Naminimianji, Maryam
Victoria University of Wellington
maryam.naminimianji@yahoo.com

McDonald-Wharry, John
University of Waikato
john.mcdonald-wharry@waikato.ac.nz

The National Science Challenge has brought together researchers from a variety of different disciplines. In the Science for Technological Innovation Portfolio 5, “Additive manufacturing and 3D and/or 4D printing of bio-composites”, material scientists have been collaborating with industrial designers. This close working partnership has led to the development of formulations of unique biopolymers with thermal shape shifting properties customised around additive manufacture requirements and design-led applications. This presentation documents two design projects demonstrating how biopolymers can be engineered to deliver novel 4D functionality.

Both research projects included a very beneficial student internship for two Masters of Design Innovation (MDI) students from VUW (Maryam Naminimianji, Yejun Fu) working alongside a material scientist, Dr John McDonald-Wharry, at UoW, to gain a lab-based understanding of biopolymer formulation processes and to acquire hands-on experience of paste printing. An iterative process of printing tests was undertaken, with modifications made to both the formulations and the printer settings to improve printability and material performance.

The two studies continued with design experiments exploring how to configure geometry and form in order to maximise the benefits of shape shifting transformations. Each project further developed its own unique design application, with one focussing on large scale flat pack furniture and the other on adaptive wearable splints. The flat pack furniture project utilised a large industrial robotic arm combined a custom fabricated large-scale paste extruder to print a series of 2D print prototypes that transformed into 3D forms, while the 4D properties of the adaptive splint were customised to the shape, movement and physiological requirements of an individual’s progressive rehabilitation.

This presentation documents the processes and design outcomes.

Tim Miller studied at Kingston University and UNSW and has many years of experience as an industrial designer, design consultant, educator and researcher in emerging technologies. For the last 20 years he has focused on education and researching the design opportunities of emerging digital manufacturing technologies.

Polymers for 4D Printing

Presenting Author

Imrie, Patrick
The University of Auckland
pimr761@aucklanduni.ac.nz

Jin, Jianyong
The University of Auckland (Faculty of Science)
j.jin@auckland.ac.nz

4D printing is a recent advancement in additive manufacturing that takes traditional 3D printing and adds the dimension of time. Objects printed by this method have the ability to change or develop new features when removed from the printer. This evolution is in response to an applied stimulus such as heat, light, magnetic field or water. The effects exhibited by 4D printed structures include changes in shape, electrical resistance, stiffness and magnetisation. 4D printing presents a variety of potential applications in many different fields, such as biocompatible soft robotics for use in medicine and componentry for wearable electronics.

In this review, the current worldwide developments in the 4D printing of polymers are discussed. The basic 3D printing techniques for polymers are explained first. Next, we take a look at the various polymeric materials which may be 4D printed. These include Shape Memory Polymers (SMPs), hydrogels, organogels and Liquid Crystal Elastomers (LCEs). The mechanisms behind how these materials undergo changes when stimulated are investigated. Examples of research in this field are also discussed, and how they may be applied outside the laboratory.

Also included is a short summary of a recent contribution to the field made by our group. We managed to print a polymer structure whose chains could be reactivated upon light stimulation, giving it a “living” character. This allowed us to add different monomers to the polymer chains. Through this addition, we could change the structure’s hydrophilicity and cause it to develop fluorescence. This discovery presents a bright future for additive manufacturing, and puts New Zealand at the forefront of 4D polymer printing research.

Patrick Imrie is a student at the University of Auckland currently working towards a BSc with Honours in Chemistry. He aims to complete his degree this year under the guidance of Dr Jianyong Jin.

Additive manufacturing with responsive composite materials and biobased polymers

Presenting Author

McDonald-Wharry, John

University of Waikato

john.mcdonald-wharry@waikato.ac.nz

Pickering, Kim

University of Waikato

kjp@waikato.ac.nz

Le Guen, Marie-Joo

Scion

MarieJoo.LeGuen@scionresearch.com

Barbier, Maxime

Scion

Maxime.Barbier@scionresearch.com

Bridson, James

Scion

Jamie.Bridson@scionresearch.com

As part of the Science for Technological Innovation National Science Challenge (NSC SfTI), a project is underway titled “Additive manufacturing and 3D and/or 4D printing of bio-composites”. In the first three years of this project a range of bio-derived composite materials have been formulated, 3D-printed, and characterised. Responsive materials such as shape memory polymers are under investigation to bringing 4D-functionality to 3D-printed structures. This presentation will focus on selected material formulations and processing approaches developed within this NSC SfTI project; specifically the biobased, thermoset nanocomposite materials developed through a collaboration between the University of Waikato and Scion. These thermoset polyester composite formulations are composed of plant and fungi sourced raw materials including nanocelluloses. Versions of these composite materials have been used in product concepts designed by students at Victoria University of Wellington and modelled at the University of Auckland. An overview of results, achievements, and challenges from the first three years of this part of the larger additive manufacturing project will be presented along with future research directions towards potential applications. Shape memory polymers have uses in biomedical devices such as shape shifting stents and sutures. The NSC SfTI project has a focus on 3D printing biobased materials with responsive functionality, with research directed towards product concepts including wearables, orthotics, and furniture. The use of biobased polymers and composites provides an opportunity for sustainably manufactured and biodegradable products. The 4D printing concept provides scope for both product customisation and inbuilt engineered responses.

John McDonald-Wharry is a lecturer and materials scientist at the University of Waikato with a focus on the valorisation of biomass. Research interests have included characterising carbohydrates from radiata pine, developing nanostructural models for carbonised biomass, creation of composite materials from carbonised biomass, and developing biobased composite formulations for additive manufacturing.

New opportunities for microfabrication

Presenting Author

Bubendorfer, Andrea

Callaghan Innovation

andrea.bubendorfer@callaghaninnovation.govt.nz

Best, Andrew

Callaghan Innovation

andrew.best@callaghaninnovation.govt.nz

Jones, Harrison

Callaghan Innovation

harrison.jones@callaghaninnovation.govt.nz

Sir Paul Callaghan described that “manufactured and knowledge-based exports with high product value per unit weight and per employee”, underpin the wealth of the world’s advanced economies and are “New Zealand’s best opportunity for sustainable, environmentally benign economic growth”. Microfabrication is the technology underpinning the ongoing miniaturisation trend behind all high-tech devices, enabling applications where size and weight are critical, eg the hardware of the IoT, wearables, medical devices and the aerospace industry. It is an industry well aligned to Sir Paul’s ambition with high value, small form-factor products easily exported to a growing global market. Recognising the large and growing opportunities for our agile and responsive small companies to disrupt the market, Callaghan Innovation created the new “Laminated Resin Printing” (LRP) technology to enable fabricating microstructures with significantly lower cost, greater ease of use, faster turnaround and extreme 3-dimensionality compared to conventional microfabrication techniques.

LRP polymerises high quality microscopically thin dry film photoresists following activation by UV light and lamination to form multilayer structures. Effectively this means structures are built within layers of support, so uniquely LRP can make flexible structures such as overhangs & membranes. These are the springs inside physical sensors, used in applications such as displaying your phone screen orientation. And unlike other techniques, it is inherently scalable from prototype to production, so there is a direct path to manufacturing without changing your design. This talk will discuss new opportunities enabled by LRP such as point-of-care devices, sensors, shadow masks and optics.

Andrea Bubendorfer is a principal scientist & leader of the Microfabrication and Molecular Sensing team at Callaghan Innovation. She is co-inventor of Laminated Resin Printing and her work has primarily been around enabling microfabrication technologies.

Design of a novel stent for haemorrhage control

Presenting Author

Garcia, Lorenzo

Auckland University of Technology

lorenzo.garcia@aut.ac.nz

Jones, Nick

Auckland University of Technology

mdd7657@autuni.ac.nz

An internal haemorrhage is a loss of blood from a vessel that collects inside the human body and it can occur at any location within arterial or venous systems. The technology designed aims to address intracranial haemorrhages which initially form as a saccular aneurysm. Intracranial aneurysms occur when cardiovascular disease causes the thinning and/or weakening of the artery wall.

Inspired by a variation of a cardiovascular graft stent, a new system is conceptualized, and it allows the stent to be both inserted and removed intravenously from within the patient.

The final design consists of Nitinol flat wire (0.05 * 0.2 mm), shaped in a spiral and spaced 10 mm intervals through an ePTFE skin. The stent is designed to fit an intracranial artery with a diameter of 3mm and can be deformed to a diameter of 1mm during insertion.

In order to insert the stent intravenously in its correct location then have it reform to fit the artery, an insertion – removal utensil was also designed. In this presentation, the different stages of the design are going to be discussed as well as the validation procedures.



Figure: Insertion tool dispensing the stent into the artery. After insertion, the stent then reforms to fit the artery.

Lorenzo Garcia is a Bio Design Engineer and a Lecturer at AUT since 2016. His research area is Medical Devices and Biomechanical Design. Previously, since 2003, he was working as Innovation Manager where he got extensive experience in Technology Transfer, Patent Searching and Business Model Generation.

Design and manufacture of a patient handling system for a novel upright MRI system

Presenting Author

Wells, Christy

School of Design, Victoria University of Wellington

christy.wells@vuw.ac.nz

Rodriguez-Ramirez, Edgar

School of Design

Victoria University of Wellington

edgar.rodriguez-ramirez@vuw.ac.nz

Parkinson, Ben

Robinson Research Institute

Victoria University of Wellington

ben.parkinson@vuw.ac.nz

Lemke, Mailin

School of Design

Victoria University of Wellington

mailin.lemke@vuw.ac.nz

Magnetic Resonance Imaging (MRI) is an indispensable tool for imaging of the human body for diagnostics and guided interventions. However, traditional MRI imaging has limitations such as installation cost, heavy weight, permanent fixture and restriction of the body in a prone positioning. An upright, head-only MRI system was designed to address these issues. This paper addresses the design and manufacture of a patient handling system for this novel MRI scanner to situate patients comfortably, upright and accurately in the bore of the scanner.

This research used a human centered design methodology to guide an experimental and iterative design process. The process included the development of a series of 1:1 full scale functional prototypes that were tested with participants. Validated questionnaires were utilised during user testing to evaluate the prototypes against anxiety, usability and comfort. The resultant design was successful in ensuring accuracy of head placement for 5-95 percentile users. Comfort was addressed using upholstery for support and adjustable elements to accommodate a range of percentiles. Anxiety was minimized by giving patients a sense of control; by managing their personal placement in the scanner, as well as providing a window for vision and communication with clinicians. The design of a coherent system in the familiar shape of a lounge chair supported successful usability. Further studies in clinical practice are required to validate our Formative Usability Evaluation results with a higher number and variety of participants.



Christy Wells is a recent graduate of the 'Master of Design Innovation' program at Victoria University. Her research focused on the design and manufacture of a novel MRI system which allows accurate scanning positioning, and encourages comfortable user experience for patients.

Developments and opportunities in medical textiles

Presenting Author
Kankariya, Nimesh

*Centre for materials science and technology, University of Otago
nimeshjain87@gmail.com*

Laing, Raechel M

*Centre for materials science and technology,
University of Otago
raechel.laing@otago.ac.nz*

Wilson, Cheryl A

*Centre for materials science and technology,
University of Otago
cheryl.wilson@otago.ac.nz*

Medical textiles are one of the fastest growing fibre/materials sectors reflecting a strong demand from developed economies and an increasing demand from developing countries. The global medical textiles market is expected to reach US \$20.23 billion by 2022. Although the 2020 Covid-19 pandemic makes predictions of many aspects of economies and health speculative (i.e. ill-defined adverse effects on manufacturing in many countries, interrupted supply chains among countries), development of fibre/textile products in the health sector is likely to continue. The advantaged position of New Zealand in this context presents opportunities. Identifying recent developments and opportunities in medical textiles / products (limited to non-implantable, healthcare, and hygiene products) was the aim of this investigation. Scientific literature on developments in this group of products was identified via Google Scholar, PubMed Central® library, and websites for medical textiles products, and these were reviewed.

Medical textiles are varied in their application: bandages and plasters of many types, compression stockings, surgical gowns and aprons, masks and head coverings, foot coverings, blankets/bed covers and underlays. Being able to capitalise on opportunities requires at least some knowledge of different scientific disciplines (e.g. textile engineering/ chemistry/ physics, and how these intersect with human physiology in health and disease), and a willingness to work across disciplines.

Nimesh Kankariya is a doctoral student in the University of Otago. His research addresses key questions on textile-based compression therapy. Before coming to New Zealand, he worked as a research associate at PolyU, Hong Kong, and IIT-Delhi, India. He holds a Master of Technology degree in fiber science from IIT-Delhi.

Design and development of a quick release arm brace for a paralympic cyclist

Presenting Author

Stilwell, George

*Mechanical Engineering Department, University of Canterbury
george.stilwell@pg.canterbury.ac.nz*

Symons, Digby

*Mechanical Engineering Department University
of Canterbury
digby.symons@canterbury.ac.nz*

Murton, Benjamin

*Mechanical Engineering Department University
of Canterbury
benjamin.murton@pg.canterbury.ac.nz*

The 1-kilometre individual time trial is a track cycling event that requires the cyclist to complete the distance as fast as possible from a standing start upon a bicycle which meets Union Cycliste Internationale (UCI) rules. The project described in this presentation was completed in collaboration with the University of Canterbury and the New Zealand Para Cycling Team. It required a device to improve the initial start and thus final time for a C4 para cyclist with a physical impairment of their left arm. Prior to the beginning of this project, due to the nature of the impairment, the cyclist was unable to cycle in a standing position (out of the saddle). They therefore used a seated cycling position for the whole race, and this limited their initial acceleration. This project aimed to provide a device that would allow the cyclist to start out of the saddle.

A range of concepts were evaluated before building and testing functional prototypes of the chosen solutions. A range of prototypes have been developed and tested as the project has progressed. Due to the risks associated with track cycling, a solution was required that would not increase the risk of injury in the event of a crash. For this reason, the design consists of two main parts: a removable carbon fibre arm brace that engages with a quick release receiver attached to the handlebar. A lever operated by the cyclist's other arm is used to lock the receiver for the race start. In the event of a crash the receiver lock springs open and the arm brace is released.



George Stilwell is a PhD candidate in the Mechanical Engineering Department at the University of Canterbury. George's research looks at understanding and modelling upper body strength for people with C5-C7 Tetraplegia. He is interested in designing mechanical devices for people with reduced motor/sensory function.

Surface engineering by titanium particulate injection moulding

Presenting Author

Ewart, Paul
Waikato Institute of Technology
paul.ewart@wintec.ac.nz

Mangan, Kieran
Waikato Institute of Technology
kieman17@student.wintec.ac

Ahn, Seokyoung
Pusan National University
sahn@pusan.ac.kr

Capek, Lukas
Technical University of Liberec
lukas.capek@tul.cz

In a recent study a structural hold down component was designed and produced using the particulate injection moulding (PIM) process. The material of choice was titanium due not only to the material properties but also due to the desire to create custom made components for a state-of-the-art marine vessel. On removal from the mould the green parts were seen to have an irregular surface on the top face. The irregular surface presented no through part defects and although the surface irregularities were caused by separation of the two-phases the effect was restricted to the outer surface of the parts. In a more historic study by the author the surface properties of titanium dental implants were modified by the use of adaptive mould inserts during the moulding phase of PIM. These two contrasting studies are considered and have become the basis of a current investigation looking to engineer surface irregularities in an ordered fashion. The application of meso-machining, and additive manufacture are considered and the functionality which may arise are presented.

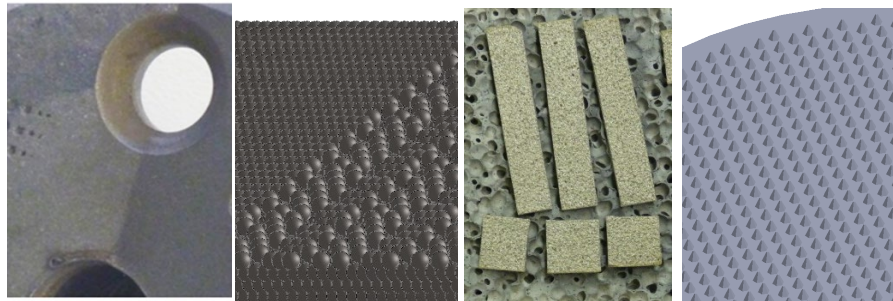

Irregular surface Modelled surface Modified surface Engineered surface

Paul Ewart obtained his PhD in 2014, was involved in the startup AME Powder Technologies, and is the current Research Leader and a teaching academic at Wintec Centre for Engineering & Industrial Design in Hamilton. His main research focus area is material processes, product development and commercialisation. He also has a particular interest in Sports Engineering.

Design and development of an apple fruitlet thinning end-effector

Presenting Author
Jangali, Rahul
University of Waikato
rjangali@waikato.ac.nz

Lim, Shen Hin
University of Waikato
hlim@waikato.ac.nz

McGuinness, Ben
University of Waikato
benjamin@waikato.ac.nz

Duke, Mike
University of Waikato
dukemd@waikato.ac.nz

Apple growing sector is a major contributor to the horticulture industry in New Zealand and is expected to be a billion-dollar industry by 2025. However, labour shortages and increased production costs due to manual labour threaten this potential growth. Technological advances in recent years have made it possible for robots to be a viable option in the orchards. This paper presents the design and development process of a robotic fruitlet thinning end effector and New Zealand's potential to be a global leader in field robotic solutions for the apple growing sector.

Navigating through the tight apple fruitlet cluster without damaging the surroundings is one of the major influencing factors for the design of robotic thinning end-effector. The proposed design consists of four fingers to move the surrounding fruitlets away from the target fruit and is connected to microprocessor controlled linear actuators. This is guided by a stereo-vision computer vision system to navigate through a tight cluster of 5-6 apple fruitlets. Advanced product design techniques and additive manufacturing technologies such as SLA and FDM composite printing were used to manufacture the mechatronic end-effector.

Lab trials were carried out on 3D printed fake apple tree branches and showed promise for the chosen design. Three field trials were conducted, and the end effector was tested on 20 fruitlet clusters each time and had a consistency of 80% success rate at navigating through the fruitlet cluster to lock on to the target fruit. The research highlights how the use of advanced methods and technologies, can be used to develop complex solutions for New Zealand's AgriTech sector.

Rahul Jangali is a PhD researcher current working on a MBIE funded research project and also a doctoral assistant at the School of Engineering, The University of Waikato. Main research interests lie in automation, design and development of agricultural robots.

A review of the most recent development in adhesively bonded joints for metal/composite structural frameworks

Presenting Author

Saniee, Ardeshir

Department of Mechanical Engineering, Auckland University of Technology
ardeshir.saniee@aut.ac.nz

Schaefer, Marcel

Auckland University of Technology
marcel.schaefer@aut.ac.nz

Chen, Zhan

Auckland University of Technology
zhan.chen@aut.ac.nz

Lin, Richard J.T.

The University of Auckland
rj.lin@auckland.ac.nz

Jayaraman, Krishnan

The University of Auckland
k.jayaraman@auckland.ac.nz

Our society is in high demand for lighter structures in various industries. There is a clearly stated need to reduce the consumption of fossil fuels in transportation. A major part of this endeavour is to employ light-weight materials in structural applications, including common metallic materials such as steel and aluminium coupled with composite materials (e.g. Carbon Fibre Reinforcement Composite).

Dissimilar material joints showed excellent potential for the range of engineering applications recently. Different material combinations could be applied for advanced engineering applications in the field of aerospace and automotive industry based on their requirements to develop components with higher performance and less weight. In line with these requirements, the high strength and good formability of metals can be integrated with excellent lightweight and chemical properties of polymeric materials using appropriate joining methods. To date, the joining process is still a major cost source.

Different joining methods can be used to develop a composite/metal structural framework such as mechanical fastening, spot welding or adhesive bonding. Despite its unique advantages, adhesive bonding introduces different challenges. A significant number of research studies have been conducted to overcome these limitations during the last decades. However, due to its complex mechanisms and its multidisciplinary character, this method is less trusted among engineers, especially when the durability is the primary concern.

In this presentation, we will discuss the most recent developments in adhesively bonded joints for metal/composite structural frameworks. The basic phenomena of bonding methods will be discussed as well as the importance of different parameters which can influence the short- and long-term performance of the adhesively bonded joints such as joint configuration, surface preparation and material parameters of adhesive/adherend.

Ardeshir Saniee is a Mechanical Engineering PhD candidate at AUT. His research aim is to investigate the influence of different surface treatments, both mechanically and chemically on surface characteristics in a molecular scale, to identify the correlation between different surface characteristics with initial strength as well as durability of the adhesively bonded joints.

Surface modifications and coatings for improved energy efficiency and performance

Presenting Author

Leveneur, Jérôme

GNS Science
j.leveneur@gns.cri.nz

Kennedy, John; Gupta, Prasanth

GNS Science
j.kennedy@gns.cri.nz
p.gupta@gns.cri.nz

Loho, Thomas

The University of Auckland
thomas.loho@auckland.ac.nz

Over the past 10 years, GNS Science has observed a regained interest from industry for improved surface performance. This ranged from metallic-looking decorative coatings with better adhesion strength on soft plastics, to hard wearing coating for increased lifetime of car engine parts. This even included inquiries to find methods to reduce fouling by changing how metal surface interacts with dairy products. The physical modification techniques available at GNS Science provide innovative solutions to these challenges.

We are working with two New Zealand motoring and engineering industry partners to develop hard wearing surfaces that can reduce friction from cam followers and give their engines an additional edge over their competition. To do so, we have investigated ion implantation and plasma-enhanced chemical vapour deposition methods to apply diamond-like carbon coatings on real parts and test them in an engine.

Drawing examples such as this one, our presentation will introduce the extent of possible surface modifications and how we work with our industry partners to positively affect the performance of their products and processes. We hope that our presentation will trigger, or re-ignite, your interest and build the confidence that these techniques are scalable and relevant.



Jérôme Leveneur is a materials scientist and innovator at GNS Science. He received his PhD in Chemistry from the University of Auckland in 2013. His research focuses on the development and application of new ion beam processes and nanotechnologies (nanomagnetism, nanocomposites, magnetoelectrics) to solve energy efficiency challenges in industry.

Realising value from science

Presenting Author
Sharplin, Nigel
InFact Limited
nigel@infact.co.nz

Realising value from the nations investment in science is a key strategic focus for government, with pressure on institutions to not only pay their way but to also start solving for the worlds complex economic, social and environmental problems.

The challenge for New Zealand science organisations is to build pathways to market that not only provide the learning required to refine the product and service offering to fit precisely with the end customers' requirements but more critically to establish a scalable enterprise that has the capability and capacity to engage with new channels partners.

Because we all work within the constraints of our specialist knowledge area we need to find new ways of enrolling and engaging others who know and understand how to connect with different parts of the value chain to not only achieve a footprint of initial sales but also scale up.

InFact has facilitated a process of commercial product and service development over the last 22 years helping get science off the lab bench and into commercial production. Collaborating with organisations such as Scion, AgResearch, AU, UC and Lincoln to understand their end user's needs, design and develop commercially viable technology and to establish the production capability to deliver these unique product and service offerings.



Nigel Sharplin, as Managing Director of InFact – New Zealand's leading hi-tech product design engineering firm, has, in 22 years, delivered over 400 new products to market for science organisations and leading exporters. With strong commercial, design thinking and innovation capabilities he has built a team that delivers exceptional products to market.

Effect of CNC machining on perceived tactile properties of native and non-native timbers

Presenting Author
Emerson, Nicholas
School of Product Design
University of Canterbury
nick.emerson@canterbury.ac.nz

Nazmi, Ali Reza
School of Product Design
University of Canterbury
alireza.nazmi@canterbury.ac.nz

Huber, Tim
School of Product Design
University of Canterbury
tim.huber@canterbury.ac.nz

Successful design involves selecting materials and processes that enhance the perceived quality of finished products. The products' visual aesthetic and physical tactility are contributors to this quality feel. Natural materials such as timber may be considered visually interesting, softer, warmer, and more tactile than other materials, encouraging the use of timber in high quality products. Historically, design entrepreneurs have crafted timber products by hand, but the emergence of low-cost tooling through the 'maker movement' has increased the accessibility of CNC manufacturing. Whilst the technology is more readily available, information about how best to process these materials and how processing choices might impact on the customers' perception of quality is less accessible to SMEs. This is exacerbated when processing materials with wide-ranging properties, such as natural timber.

Therefore, in this study five native and non-native (to Aotearoa New Zealand) timber species were selected for analysis. Two test samples were created from each timber; a flat-sided cube prepared using basic cutting/planning, and a sample with curved surfaces prepared via CNC. Basic mechanical properties (density, hardness) were obtained for each timber. Participants' tactual perception of the samples was gathered using a four-dimensional (geometric, physical-chemical, emotional, and associative) framework in blind- and non-blindfolded tests, coupled with an assessment of perceived overall quality.

The study will determine if using consistent processes to produce samples from varying timbers impacts upon the perception of quality, and if this relates to visual aesthetics. The study will explore physical material parameters and human perception to examine the link between what is felt and what is measured in design and manufacture. The outcomes of the study can be used to better understand the CNC processing requirements, allowing entrepreneurial designers and SMEs to produce high-quality, appealing products using digital manufacturing techniques.

Nick Emerson is a senior lecturer in the School of Product Design, teaching Engineering and Digital Design skills for Product Design students. He is engaged in the integration of engineering science, digital design, analysis, and manufacturing in the product design process and considering their impact on productivity and project outcome.

Fatigue behaviour of carbon-fibre epoxy composites with resin flow channels

Maletira Karumbaiah, Kariappa
 Centre for Advanced Composite Materials (CACM)
 Department of Mechanical Engineering
 The University of Auckland
 m.kariappa@auckland.ac.nz

Kracke, Christoph
 BMW
 Christoph.Kracke@bmw.de

Battley, Mark
 CACM, The University of Auckland
 m.battley@auckland.ac.nz

Bickerton, Simon
 CACM, The University of Auckland
 s.bickerton@auckland.ac.nz

Allen, Tom
 CACM, The University of Auckland
 tom.allen@auckland.ac.nz

Fatigue behaviour of composite material systems is an important area of composites research. While scholars continue work on understanding the mechanics of composite fatigue fracture, industries must test their components for fatigue performance to guarantee customers safety and contentment. However, testing fatigue behaviour of composite materials is machine and time expensive.

Designing and predicting the failure modes and fatigue strength of composite structures is a challenging task. There are number of theoretical concepts available to the designers to predict failure, however they are limited to general loading and structural conditions. Intentionally induced manufacturing features such as resin flow channels and the lamina level architectural variations caused by the design process results in increased testing efforts ranging at lamina level to a large scaled structure. These testings are conducted to achieve a level of confidence in the materials system and designs.

The flexural fatigue behaviours of composite laminates, both with and without resin flow channels, were investigated to identify the fatigue life evolution of composite laminates. Acoustic emission measured damage accumulation was investigated for five-cycle load/unload and full-cycle fatigue tests. The five-cycle quantities of acoustic parameters such as sum of counts and felicity ratios showed trends to identify the critical damage loads and its effects on the full-cycle fatigue performances. Hence, the proposed acoustic emission monitored five-cycle loading protocols can be implemented to understand the fatigue endurance of composites with manufacture induced features.

Kariappa is a Research Associate at the Centre for Advanced Composite Materials (CACM), the University of Auckland, New Zealand. He did his PhD on the effects of manufacturing induced features on damage evolution in carbon-fibre epoxy composite laminates. He is primarily involved in academic and industrial research works in the areas of composite structural analysis at CACM.

Fabrics as sensors: effects of external factors on performance

Presenting Author
 Wilson, Sophie
 University of Otago
 wilso862@student.otago.ac.nz

Laing, Raechel
 University of Otago
 raechel.laing@otago.ac.nz

Tan, Eng Wui
 University of Otago
 ewtan@chemistry.otago.ac.nz

Wilson, Cheryl
 University of Otago
 cheryl.wilson@otago.ac.nz

Creation of electrically conductive fabrics by application of post manufacture treatments is resulting in a wide range of fabric sensors potentially suitable for next to skin applications^{1,2}. Performance as a sensor is based on change in electrical conductivity in response to an external agent: e.g. a physiological parameter (skin temperature, humidity, body movement, respiration rate, heart rate) or environmental factor (ambient temperature and humidity, presence of gas, ultraviolet light). With wearable sensors, transience (motion, temperature, humidity) is typical with both the sensor on or adjacent to the body, and the external environment in which it is used.

Many substances applied to fabrics, such as intrinsically electrically conductive polymers, carbon, graphene, are responsive to one or more of the agents. A multi-purpose sensor offers advantages over a sensor detecting a single parameter. However, sensitivity to more than one parameter can result in validity issues because the change in electrical conductivity may result from more than one variable or combination of variables. Understanding how interference (i.e. an additional response to the sensor stimulus) affects the signal is critical. In some applications validity is absolutely critical (health monitoring for medical/general wellbeing, and for workplace exposures to hazardous substances).

While fabric sensors have been developed successfully to identify and/or monitor selected agents, there is a lack of discussion and investigation on interference from variables which can compromise performance. The present work explores this issue: sensor performance during wear, use, and over time. Previous experimental research is reviewed and potential interferences highlighted. Methods which may be used to quantify effects of potentially interfering parameters are outlined.

Sophie Wilson is a PhD student at the University of Otago. The area of research is focused on textiles worn next to the skin, especially involving functionalisation of these fabrics to increase prospects of use beyond conventional apparel e.g. wearable technology.

Effect of yarn arrangement in fabric on water transfer from wet textile to vitro-skin®

Presenting Author

Abdolmaleki, Sahar

Clothing and Textile Sciences, University of Otago

sahar.abdolmaleki@postgrad.otago.ac.nz

Wilson, Cheryl

Clothing and Textile Sciences

University of Otago

cheryl.wilson@otago.ac.nz

Laing, Raechel

Clothing and Textile Sciences

University of Otago

raechel.laing@otago.ac.nz

In some skin disorders, such as atopic dermatitis and epidermolysis bullosa where the skin is dry, a suitable textile for use against the skin is one which retains moisture and/or transfers at least some moisture to the skin, improving skin hydration. Few investigations have considered water transfer from wet textiles to the skin. However, it is known that in addition to fibre type, the way in which yarn has been arranged to form fabric can affect water transfer.

In order to identify fabrics which will enhance hydration, the effect of different fabric structures needs to be considered. Testing using human or animal skin has important implications in terms of ethical considerations, cost, and variability. This work reports testing using vitro-skin® as a human skin substitute when examining the amount of water absorbed per gram of vitro-skin® (change in skin mass) over time.

The change in vitro-skin® mass when skin was in contact with wet nylon fabrics was determined (water content per gram of fabric ~ 30%). Change in vitro-skin® mass was greater under wet nylon fabric formed into firm structures than that under a more open one. The water transfer trend was one of an initial increase in vitro-skin® mass followed by a decrease over time. This trend has use implications in terms of optimal exposure time before textiles requires recharging with water.

Sahar Abdolmaleki is 3rd year PhD student in Clothing and Textile Sciences, at the University of Otago. Sahar holds a MSc and BSc in textile engineering, from Amirkabir University of Technology, Tehran, and has a particular interest in the interaction between the textiles and impaired skin.

Planar to whirling – an energy transfer phenomenon exhibited in Len Lye’s kinetic art

Presenting Author

McGregor, Angus

University of Canterbury

angus.mcgregor@pg.canterbury.ac.nz

Gooch, Shayne

University of Canterbury

shayne.gooch@canterbury.ac.nz

Kinetic artists often make use of unusual dynamic behaviours to create their art. New Zealand born artist Len Lye was renowned for his use of highly flexible elements fabricated from spring steel, fibreglass, and posthumously in titanium. These flexible elements were often paired with unique mechanisms Lye designed to elicit particular mode shapes, and explore the balance of control between the vibrating element and the drive mechanism.

Lye hid the flexible machines driving his kinetic sculptures on the world stage throughout the ‘movement’ movement of the mid-20th century. Here we show some of the observations and practical implications stemming from these early flexible machines relevant to modern machine design, and the control of large amplitude vibrations

Recent interest in Lye’s mechanisms stems from a conservatory desire to minimise changes when enlarging Lye’s sculptures. Lye left behind plans to develop his sculptures into ‘monumental’ versions more than 10 times the originals size. Due to the disparity between model and monument, it is often uncertain whether dynamic features will continue to exist.

While new machine designs may reliably reproduce the desired features in a more controlled way, new mechanisms also introduce differences into the performance. To minimise this drift of the artistic concept over time, analysis into the scalability of features from Lye’s original mechanisms has helped to set a precedent for retaining Lye’s original machine designs in larger works.

Following Lye’s death in 1980, the Len Lye Foundation was established to promote and preserve the Len Lye collection. Soon after, a collaborative relationship evolved between the Department of Mechanical Engineering at the University of Canterbury and the Len Lye Foundation

Angus McGregor is a mechanical engineer and PhD student in the Mechanical Engineering Department at the University of Canterbury. He completed a degree in Mechanical Engineering, and has worked alongside the Len Lye Foundation since 2015.



Compliant grippers – an additive approach

Presenting Author
Barnett, Josh
University of Waikato
joshuab@waikato.ac.nz

Lim, Shen Hin
University of Waikato
hin.lim@waikato.ac.nz

Duke, Mike
University of Waikato
mike.duke@waikato.ac.nz

Soft handling is a key factor towards robotic automation in agriculture but also across the produce and packaging sectors. Delicate objects require a soft “hand” to make sure they are not damaged; this is especially true for high value crops such as asparagus. We present here a food-safe compliant gripper – selective laser sintered (SLS) in thermoplastic polyurethane (TPU) which was used to robotically harvest asparagus.

As part of our prior work in robotic harvesting, we have used complex silicon over-moulds to add compliance and to prevent fruit damage. This method has worked well, but remains a multi-stage manufacturing process. Recent availability of SLS elastomer printing allows for variable compliance across a part, such that a single-stage print may be all that is needed for soft handling. We discuss some of the advantages and disadvantages with this approach and report on field trials where our SLS TPU gripper is evaluated next to a more conventional gripper.

Development time remains an issue and conventional CAD tools lack the functionality to quickly re-configure complex 3D printed parts such as grippers. We propose a software-as-a-service (SaaS) parametric design workflow for customization.

Josh Barnett is a design engineer working within the WaiRAS research group at University of Waikato. He has a keen interest in applied robotics and has designed and built a range of research hardware and acclaimed mechatronic systems.

Development of HTV silicone within New Zealand

Presenting Author
Bunnett, Charlotte
Peke Waihangā – Artificial Limb Service
charlotte.bunnett@nzals.co.nz

White, Holly
University of Waikato
holly.white@nzals.co.nz

Jackson, Monique
Peke Waihangā – Artificial Limb Service
monique.jackson@nzals.co.nz

Peke Waihangā – Artificial Limb Service specialises in high technology medical devices, mainly prosthetics, for over 4300 patients across NZ. Developing innovative manufacturing technologies is core in supporting our vision of independent and productive lives.

Peke Waihangā is committed to advancing bespoke manufacturing and design techniques. We have developed agile teams focused on socket technologies, digital manufacturing, and silicone.

In collaboration with the University of Waikato, Process Engineering School, Peke Waihangā identified the need for High Temperature Vulcanising (HTV) Silicone manufacturing technology to be developed within NZ. This would be a niche service, developing silicone devices to improve patient comfort resulting in better outcomes for NZ amputees.

The advantages of HTV silicone manufacturing directly within Peke Waihangā will eliminate or reduce barriers such as high cost, long/delayed delivery times due to overseas suppliers, and communication issues. The manufacturing facility is in place, product development underway and trials being conducted.

With proven benefit to upper limb amputees, the local development of HTV silicone has numerous areas for growth. This includes integrating robotics and automation, 3D printing articulating internal componentry, and printing HTV silicone as an extruded material.

Peke Waihangā has available a Contestable Research Fund of \$20,000 to promote research into issues that will benefit amputees. Appropriate topics may include research on, components, materials, and any related topics with a focus on engineering and biomechanics.

Charlotte Bunnett is a Prosthetic Technician & Silicone Lead at the Hamilton Centre. Her research interest lies in innovative technologies and adapting and developing these to better improve amputee's everyday lives.

High resolution electrohydrodynamic printing for flexible electronics and sensor fabrication

Presenting Author
Rehmani, Muhammad Asif Ali
Massey University
m.a.a.rehmani@massey.ac.nz

Arif, Khalid
Massey University
k.arif@massey.ac.nz

Development in the area of flexible sensors is receiving greater importance due to their wearability and applicability to irregular surfaces. Discrete modules of readout and signal enhancement modules are getting smaller in packages and their overall footprint augments the fabrication of standalone and flexible electronics for next generation wearable sensors and soft robotics. The intermediary process for fabricating these sensors needs to be scalable and reconfigurable so that the same can be used for diverse applications.

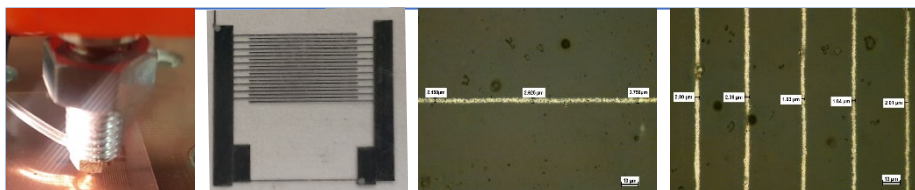

Figure 1 – EHD printed transduction electrodes and printed lines

In this regard Electrohydrodynamic (EHD) printing has received immense attention recently. EHD printing is an additive printing of ink at fine resolution much smaller than the size of the ejecting nozzle. Unlike the piezo-actuated or thermal inkjet printing the printing ink can have higher viscosity, higher concentration of nanoparticles and higher density. Most of the EHD printing system is based on decreasing the size of the ejecting nozzle which is susceptible to blockage and is delicate for long term usage.

In this work we demonstrate the possibility of printing fine resolution features by carefully designing the printhead which has the nozzle ejection diameter of 500µm large enough to be able to utilize inks which conventional inkjet printing cannot handle easily. The overall achieved resolution of printed feature is less than 2µm and the ratio of nozzle diameter to the printed feature is much higher than the available EHD printing setups. The bigger nozzle size and fine resolution of printing opens the possibility of realizing the functional 4D printed smart sensors for myriads of applications.

Muhammad Rehmani is currently completing final year of PhD at the Department of Mechanical and Electrical Engineering, Massey University Auckland. He holds a master's degree in Mechatronics from Jeju University, South Korea and has more than 10 years' industry experience in different roles. His research interests include sensing technology, printed electronics, 3D printing and instrumentation.

Fabrication and characterisation of 3D printed microchannels

Presenting Author
Jaywant, Swapna A.
Massey University
s.jaywant@massey.ac.nz

Rehmani, Muhammad Asif Ali
Massey University
m.a.a.rehmani@massey.ac.nz

Arif, Khalid
Massey University
k.arif@massey.ac.nz

Recently, 3D printing has been rapidly gaining an interest in the field of microfluidics due to its advantages such as automated fabrication, cost-effectiveness, availability of a wide range of materials, single-step procedure, etc. Microchannels are an essential part of micro-mixing in microfluidic devices. The mixing in the channels is primarily dependent upon diffusion of different fluids. The flow rate and channel length are important parameters to achieve effective mixing. Many of these parameters have been thoroughly studied by researchers in the past, however, the design of microchannel, its size, and the effect of fluid pressure have not been investigated together explore the possibilities of leakage through the microfluidic devices.

In this research, we present a feasibility study of developing internal features of microfluidic devices with polymer-based 3D printing technologies using non-transparent materials. The printers are assessed in terms of accuracy, feature size and aptness for assembly line production. A laminar flow study is also performed to evaluate the flow channels (Fig. 1). The study includes minimum possible channel size, fluid flow-rate, and leakage in the micro-channel body. Further, printed parts have been analyzed to observe the absorbance of the fluid due to the presence of voids in the layers. Additionally, the effect on the microchannels' performance after treating them with acetone has also been explored.

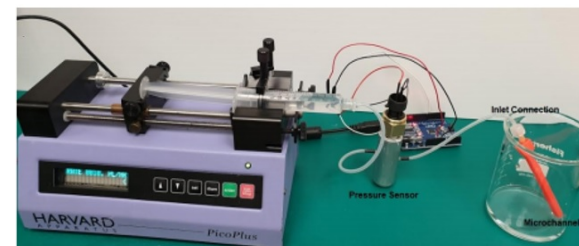

Fig. 1 Experimental set up for characterization of microchannels

Swapna A. Jaywant recently completed her PhD in Engineering at Massey University. Currently, she is working as a research associate in the Sensors and Smart Systems Laboratory at Massey University Auckland. Her areas of research interests include sensing technology, microfluidics, bioinstrumentation, and additive manufacturing.

Thermal 3D screen printing of sacrificial wax moulds

Presenting Author
Najaf Zadeh, Hossein
University of Canterbury
Hossein.najafzadeh@canterbury.ac.nz

Clucas, Don
University of Canterbury
Don.Clucas@canterbury.ac.nz

Huber, Tim
University of Canterbury
Tim.Huber@canterbury.ac.nz

A thermal 3D screen printing method has been developed to print wax moulds to cast hydrogels. In this technique, a CAD model of a periodically varying structure such as gyroid is sliced into a number of layers and these slices are used to make screens. By printing successive screens (layers) a mould of sacrificial wax is fabricated in order to cast hydrogels. The driving focus of the development was to cast cellulose hydrogels for manufacturing structured stationary phases of chromatography columns. The chromatography columns manufactured by this method are used to separate the components of a mixture for later use.

The advantages of thermal 3D screen printing hydrogels using wax moulds as opposed to other additive manufacturing methods are its high-speed, high-resolution part fabrication, and the ability to fabricate large parts in large batches. Moreover, the wax can be recycled and reused. This makes hydrogel part fabrication economical with a low processing cost. This method enables casting of a large range of materials, such as polymers, metals, and ceramics. Current research efforts are investigating these applications of thermal 3D screen printing.

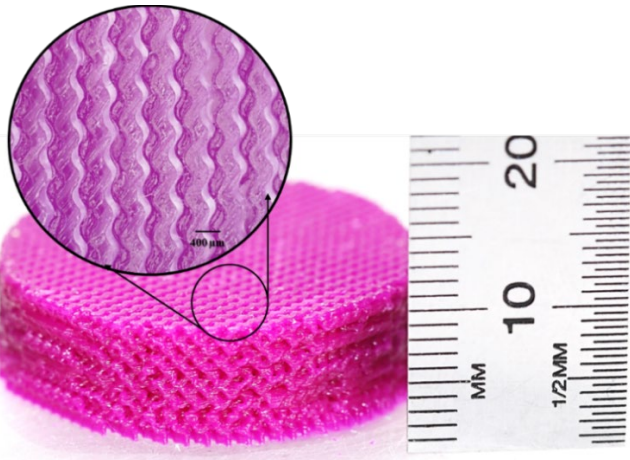

Hossein Najaf Zadeh obtained his PhD in engineering at the University of Canterbury and currently works as a post-doctoral researcher. He completed his M.Sc. and his B.Eng. in Mechanical Engineering at the University of Greenwich, England. His research interests are Additive Manufacturing, 3D printing of biobased materials and product design and development.

The design for additive manufacturing of compliant mechanisms for application in the aviation industry

Presenting Author
Singhal, Ishaan
Creative Design and Additive Manufacturing Lab (CDAM Lab), The University of Auckland
isin000@aucklanduni.ac.nz

Diegel, Olaf
CDAM Lab, The University of Auckland
olaf.diegel@auckland.ac.nz

Ferreira, Arno
CDAM Lab, The University of Auckland
arno.ferreira@auckland.ac.nz

Schutte, Juan
CDAM Lab, The University of Auckland
juan.schutte@auckland.ac.nz

Compliant mechanisms are flexible mechanisms that can apply force through elastic body deformation. Designs that use this ability can offer advantages such as increased performance (e.g. high precision, low weight, low friction) and low cost (e.g. simplified manufacture, reduced part count).

As compliant mechanism-based design is in the early stages in industry, this research and experimentation aims to showcase the value and various applications of compliant mechanisms that have been introduced into industry. As the adoption of part consolidation and weight reduction in the aviation industry is becoming more widespread, in part due to technologies such as additive manufacturing, this project aims to further the understanding and identify the value added by compliant mechanisms to the aviation field, through the innovation of morphing aeroplane wings.

To further improve part performance and weight reduction; smart design and manufacture through powder bed fusion will be used to create the compliant mechanism. This will allow for accurate testing of the parts and the ability to more rapidly and cost-effectively prototype compared to more traditional injection moulding and machining techniques.

The results and observations accumulated from this project thus far will be discussed; various 3D printed compliant mechanisms, morphing wings, and wing-like compliant structures will be demonstrated and explained. These observations will demonstrate the viability that the design for additive manufacturing of compliant mechanisms has in the aviation industry.

Ishaan Singhal is currently working at the Creative Design and Additive Manufacturing Lab (CDAM Lab), where he is pursuing a Masters in Mechatronics Engineering. His thesis will focus on the development of compliant mechanisms made using selective laser sintering technologies for innovations in the aviation industry.

3D-printed monolithic porous structures for biological separations

Presenting Author

Fee, Conan
University of Canterbury
conan.fee@canterbury.ac.nz

Feast, Sean
University of Canterbury
sean.feast@pg.canterbury.ac.nz

Huber, Tim
University of Canterbury
tim.huber@canterbury.ac.nz

Dolamore, Fabian
University of Canterbury
fabian.dolamore@canterbury.ac.nz

Houlton, Ben
University of Canterbury
ben.houlton@pg.canterbury.ac.nz

Gordon, Anne
University of Canterbury
anne.gordon@pgcanterbury.ac.nz

Clarke, Daniel
University of Canterbury
daniel.clarke@canterbury.ac.nz

Holland, Daniel
University of Canterbury
daniel.holland@canterbury.ac.nz

Since our first demonstration of 3D printing to create precise control of porous bed geometry for protein purification in 2013, there have been many advances in the area. The first cellulose and agarose hydrogel monoliths produced by this method comprised triply periodic minimal surface (TPMS) geometries, the Schoen Gyroid or Schwartz Diamond, with overall column dimensions of 1 cm diameter and 5 cm length. One such cellulose column, printed using a lost-wax process, with 300- μm , uniform internal channels, purified a virus from a cell culture in a single step, with a recovery of $69 \pm 4\%$. Further protein separations have also been achieved through chemical surface modifications of the materials.

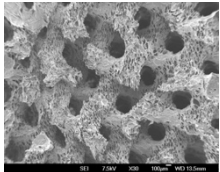

It took 28 hours to print templates for each of our original columns, while larger columns could not be produced because the associated

data files greater than a few hundred megabytes were too large for 3D printers and CAD software to handle. We have now developed software that can render complex designs of up to 10 gigabytes in minutes. Advances in printers now allow ten of the above column templates to be printed simultaneously in just 2 hours, a 140-fold increase in printing speed. We are now printing at better than 200- μm feature resolution through a lost-wax templating approach and can print multiple large columns in just a few hours, now putting designed porous structures within reach of industrial application.

Magnetic resonance imaging of internal flow velocity profiles have validated computational fluid dynamics for creeping flow, while at higher flow rates secondary flow features may explain enhanced heat and mass transfer rates observed in such structures.

Professor Conan Fee is Head of the School of Product Design at the University of Canterbury, where he leads a formulation design degree major. He pioneered research into 3D printed chromatography media and is now Science Leader of an MBIE Endeavour Programme “3D-Printed Porous Media for Process Engineering”.

Application of Additive Manufacturing for rapid product development – a case study

Presenting Author

Ferreira, Arno
Creative Design and Additive Manufacturing Lab (CDAM Lab), The University of Auckland
Arno.ferreira@auckland.ac.nz

Diegel, Olaf
CDAM Lab, The University of Auckland
Olaf.diegel@auckland.ac.nz

Schutte, Juan
CDAM Lab, The University of Auckland
Juan.Schutte@auckland.ac.nz

Yuk Lun, Chan
CDAM Lab, The University of Auckland
yzuo702@aucklanduni.ac.nz

Additive Manufacturing enables the fast, iterative design of products due to the short turnaround time to manufacture, modify and re-print. This ability to design a product or part and have a physical copy within a few hours drastically improves the product design lifecycle and aids in shortening the time to market for products.

This case study saw the design and manufacture of two versions of a medical cream dispenser in a period of less than a week. These devices aid New Zealanders and beyond suffering from cancer to apply the correct dosage of topical cream to the affected areas. Two variations of the device, a pure mechanical and an electro-mechanical version was developed relying on the user to actuate the dispensing mechanism. The electro-mechanical dispenser stores dispensing data locally and is downloaded onto the user’s computer via Bluetooth for review by their physician.

The rapid nature of the AM process allowed the designers to not only test their designs in rapid succession, but because of the properties of the Selective Laser Sintering process used, was also able to accurately test the design and its assembly for mass manufacture through traditional injection molding processes.

Arno Ferreira holds the position of Associate Director at the Creative Design and Additive Manufacturing Lab. He is part of a team whose purpose is to facilitate and educate adopters of AM on how to effectively implement this technology into various industries and their daily design methodologies

Energy absorption of FDM 3D printed TPMS structures

Presenting Author

Murton, Ben

University of Canterbury

benjamin.murton@pg.canterbury.ac.nz

Symons, Digby

Mechanical Engineering Department, University of Canterbury

digby.symons@canterbury.ac.nz

Energy absorbing materials have a wide variety of uses from packaging to crumple zones in automotive vehicles. Cellular materials such as foams and honeycombs are often used due to their ability to absorb a large amount of energy with minimal weight, but each require a compromise: foams have the advantage of isotropic behaviour but do not match the performance of the anisotropic honeycomb when crushed normal to its cells. Triply Periodic Minimal Surfaces (TPMS) have been shown by previous research to exhibit high energy absorption with a symmetrical, 3D structure. TPMS may have isotropic properties similar to foam but with energy absorption closer to the best honeycomb performance. Previously TPMS have been manufactured using metal laser sintering techniques. This is an expensive process that is limited to small scale testing. An investigation has therefore been conducted in using inexpensive polymer Fused Deposition Modelling (FDM) to manufacture TPMS and to study the effect of the nonhomogeneous nature of the process on energy absorption properties. In compression tests the energy absorption of the polymer TPMS was found to be in good correlation with existing models for metal laser-sintered variants. The Formula Student racing car at the University of Canterbury was used as an application case study. Test results show adequate performance while the polymer TPMS impact attenuator could be made for less than 10% of the cost of a laser sintered version and 45% cheaper than a commercial foam equivalent. This was achieved together with a weight reduction of up to 38% compared to a foam attenuator.



Ben Murton is a PhD candidate in Mechanical Engineering. He has a BE(Hons) in Mech Eng from the University of Canterbury. His research interests include high performance energy absorbing structures, additive manufacture, product design and prototyping.

Inkjet printing: adding value to traditional manufacturing

Presenting Author

Stringer, Jonathan

The University of Auckland

j.istringer@auckland.ac.nz

The use of digital printing technology in manufacturing is most commonly thought of in terms of 3D printing and additive manufacturing (AM), and the consequent transformational impact it can have. 2D inkjet printing, which uses the same fundamental technology as several AM techniques, is not often thought about in the same way. However, when applied appropriately it can achieve the same associated benefits (e.g. mass customisation, no need for specific tooling) in mass production of tangible products.

As an example of this, a case study is given of ceramic tile manufacture, an approximately 60 billion USD global industry. This industry, in the space of just 20 years, has adopted digital inkjet printing almost universally as a replacement for traditional printing techniques (e.g. screen printing), due to the numerous advantages it can bring. The talk will discuss how such adoption came about, and how the method of adoption can be applied to other industries, from customised cloth to aerospace composite manufacture.

Jonathan Stringer is a lecturer in the department of Mechanical Engineering, University of Auckland. His research interests and experience are in inkjet printing, printed electronics, and the 3D printing of functional materials.

Measurement of Dial Feel on appliances

Presenting Author
 Gibson, Stephen
 Fisher & Paykel Appliances
 stephen.gibson@fisherpaykel.com



Wright, Daniel; Fone, James;
 Boddy, Lochlan; Clapshaw, Richard
 University of Canterbury Students
 dwr39@uclive.ac.nz; jamesm.fone@gmail.com;
 lochlan40@gmail.com; rcl49@uclive.ac.nz



Fisher & Paykel's stated goal is to be the #1 Premium Appliance Brand globally. The perception of product quality is a key part of achieving this. In turn, the feel of the dials is one of the most important touchpoints for a product.

In the last few years Fisher & Paykel has started to analyse dial feel to aid in the improvement of perceived quality. A number of factors have been identified as contributing to a user's perception of dial feel with work being done to quantify these.

One key factor of dial feel is the torque profile, i.e. the torque required for a user to turn the dial. To measure this it was necessary to remove the dial mechanism from the product and place it in a dedicated test rig. While this works, it is unsatisfactory in having to disassemble a product.

A group of University of Canterbury students were set the task of developing a method of measuring torque profiles with the dial in-situ. This has two related uses:

- Benchmarking competitor products
- Quality checks for FPA products

This presentation will discuss the development of a mechanical gripping system and use of a strain gauge to measure torque with a good approximation of the dedicated test rig.

Torque profiles measured using dedicated rig (blue) and UoC device (red):

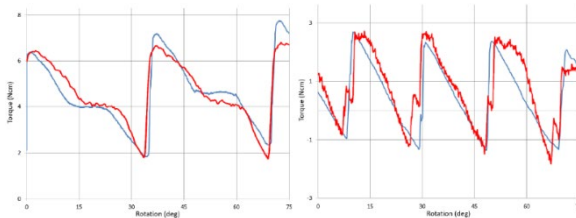

Stephen Gibson is a Product Development Engineer working in Customer Interfaces for cooking products at Fisher & Paykel Appliances, Dunedin. He has a MEng from the University of Sheffield, UK. Key areas of interest include data analysis and sensory design

The experience of prototyping for design students in a distributed world

Presenting Author
 Coutts, Euan
 University of Canterbury, School of Product Design
 euan.coutts@canterbury.ac.nz

Emerson, Nicholas
 University of Canterbury, School of Product Design
 nick.emerson@canterbury.ac.nz

The development of modern communication and online collaborative tools has helped to increase the diversity and distribution of product design teams. Where designers may once have shared a physical space, remote working and asynchronous design practices are rapidly becoming prevalent. As the world comes to terms with the events of 2020 and the post Covid-19 era, such working practices may become the norm. At the same time, the emergence of digitally-driven prototyping offers design teams a diverse range of approaches for rapid realisation during design development. Where physical model making was once the cornerstone of product design, modern techniques in computer aided design, rapid prototyping, augmented reality and virtual reality offer new opportunities to accelerate and enhance the design process and, at least in theory, lead to superior design solutions.

This study considers what constitutes a "prototype" in a contemporary design setting via a set of reflective case studies undertaken by students working in asynchronous globally-distributed teams. The students were tasked with a product design challenge and organised into teams across universities from New Zealand, the United Kingdom, Finland and Malta. The teams conducted the design challenges over eight weeks, culminating in completed design solutions. Teams were asked to reflect upon how the range of prototyping methods available to them might best be deployed, presented, and utilised and what the key differences and benefits from particular approaches might be. The study reflects upon their experiences of prototyping and how their choice of prototyping method shaped their solutions and learning throughout the design process.

Whilst a diverse range of prototyping technologies are available, the expenditure in 'buying in' to a particular methodology should not be underestimated. Understanding the most effective methodology for design development teams offers the potential to reduce capital expenditure and wasted effort during the contemporary design process.

Euan Coutts is a lecturer in the School of Product Design at the University of Canterbury, with a background in product design engineering and bioengineering, particularly medical device design. Research includes medical device design, how design methods impact solutions, and the education of technical subjects within a design context.

Design of a tandem racing bicycle

Presenting Author

Symons, Digby

*Mechanical Engineering Department, University of Canterbury
digby.symons@canterbury.ac.nz*

Brooks, Tom

University of Canterbury

tom.brooks@pg.canterbury.ac.nz

Alexander, Peter

Zenyth Projects Ltd

zenyth1970@gmail.com

For the 2016 Rio Paralympics the New Zealand women's paracycling team used a custom-built carbon fibre tandem bicycle frame that omitted the additional diagonal tube used in many tandem designs. This choice provides aerodynamic benefits but requires other parts of the frame to be enhanced to provide adequate stiffness and strength. The resulting 2016 frame design was stiff enough but was consequently also heavier than preferred. In preparation for the 2020 Tokyo Paralympics the Department of Mechanical Engineering at the University of Canterbury has collaborated with Zenyth Projects Ltd to design a new tandem frame that incorporates further aerodynamic refinements but is significantly lighter than the 2016 frame whilst retaining adequate stiffness. Computational finite element analysis has been used to assess a range of frame designs under a standing start load case. Preliminary analyses of the 2016 Rio frame and two other existing tandem designs provided benchmark values for frame stiffness and guided the design of the new 2020 Tokyo frame. Two iterations of geometry for the 2020 frame were analysed in detail, with the second giving significant improvement on the first. With the external geometry fixed the carbon fibre laminate lay-up was refined to reduce stress and optimise stiffness and mass. The final design for the 2020 Tokyo frame is 26% (1.1kg) lighter than the 2016 Rio frame whilst retaining 70% of the torsional stiffness.

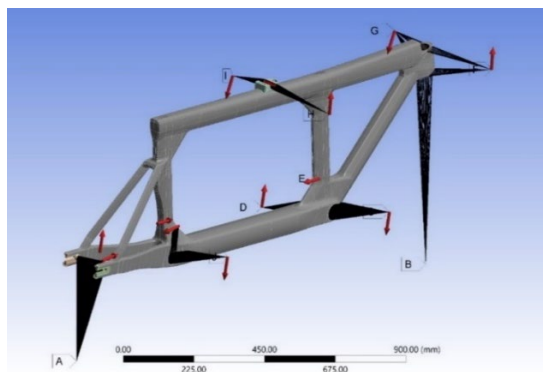

Digby Symons is an Associate Professor in Mechanical Engineering. His research interests include mechanical design, optimization, medical devices and sports engineering.

Development of magnetic inspection tool for insulated steam pipes

Presenting Author

Bailey, Joseph

*Robinson Research Institute, Victoria University of Wellington
joseph.bailey@vuw.ac.nz*

Long, Nick

*Robinson Research Institute
Victoria University of Wellington
nick.long@vuw.ac.nz*

Gouws, Gideon

*Victoria University of Wellington
gideon.gouws@vuw.ac.nz*

Insulated steam pipes are used in a wide range of chemical processing industries. One of their main failure mechanisms is corrosion under insulation. This occurs when water penetrates the insulation and corrosion initiates on the pipe surface. If not detected, this corrosion can eventually lead to pipes rupturing. Currently, plant owners have maintenance programs that physically strip the insulation layer and visually inspect it for corrosion. This is an expensive process as the insulation must be completely removed and replaced, often requiring a partial plant shutdown. With plants containing 100's of km of pipes, it can take a long time to complete a full inspection.

This presentation will review development of a new non-destructive testing tool to perform inspection of insulated pipelines without requiring removal of the insulation layer. This work has been performed in a commercial partnership between US company, QI2 and VUW's Robinson Institute. The tool developed uses an encircling coil which induces eddy currents to flow within the metal pipe walls. These eddy currents are distorted in regions where rust is present, which distorts the local magnetic field around the pipe. An array of magnetic sensors measures these distortions allowing corrosion to be detected. We will describe each stage of tool development including problem identification, proof of concept testing, prototype development, field deployment systems and blind trials. Success criteria were agreed between the project partners at each stage, and we will discuss how this approach has enabled the project to transition from concept to reality.



The system has been evaluated in blind field trials in USA and the UK, proving identification of all defect with greater than 3mm of wall loss. Testing speed reached 8.3 m/hr, indicating significant time saving compared to conventional visual techniques that require complete removal and replacement of insulation.

Image: Author undertaking testing of the non-destructive testing corrosion under insulation tool during field trials in Houston, Texas.

Joseph Bailey is a Research Engineer and PhD student at Robinson Research Institute, Victoria University of Wellington. He has spent the last 6 years developing non-destructive testing tools based on magnetic sensors. His work focuses on taking new technology and developing tools that are ready to be used by industry.

Engineering and marketing collaboration at the front end of innovation: a case study of a medical device company

Presenting Author
Gomes, Lizanne
The University of Auckland
lgom498@aucklanduni.ac.nz

Krull, Elisabeth
Research Fellow, Cass Business School, United Kingdom
elisabeth.krull@city.ac.uk

Innovation in the medical device industry has the potential to alleviate a growing burden on global healthcare costs through improving diagnostics, patient treatment, quality of life and, ultimately, saving more lives. While the overall innovation process for medical devices is well understood, the details of the front end of innovation (FEI) are not as well defined.

The FEI is the first phase of innovation where new ideas and opportunities are identified. It shapes the success of new products during later product development and commercialisation phases. Despite its importance, the FEI is not well understood due to high levels of uncertainty ambiguity and complexity. Two functions involved in medical device innovation that work closely at the FEI are engineering and marketing. Collaboration between the two in the literature has been characterised as both vital to successful innovation but also full of conflict and friction.

The objective of this study was to understand how engineering and marketing teams collaborate at the FEI in a medical device company. To address the objective, an exploratory single case study was conducted on a medical device company based in NZ. The findings uncovered three dimensions that influence collaboration between marketing and engineering: knowledge communication, resource allocation and coordination of collaboration. These findings were then used to develop a framework for improving collaboration between engineering and marketing at the FEI within the case company which involves developing a collaborative culture and improving resource allocation for better coordination of collaboration.

This research contributes to both FEI literature as well as collaboration literature by proposing a collaboration coordination framework for the FEI. The findings provide an avenue for research into evaluating the impact of successful collaboration at the FEI and exploring how collaboration between other roles at the FEI can impact the success of medical device innovation.

Through the Master of Bioscience Enterprise programme, Lizanne was interested in topics around engineering and marketing collaboration which led to the development of her thesis topic. She is currently an Associate Product Manager at Fisher and Paykel Healthcare and is involved across the medical device innovation and development process.

Kiwi innovation on the world stage

Presenting Author
Thomsen, Ben
Blender Design Ltd
ben@blender.nz

We have the capability in New Zealand to be leaders in product innovation and manufacturing, exporting high value IP to the world. We must focus on the right opportunities that are a good fit for New Zealand and leverage strong partnerships and design as a core strategy.

Fastmount is a world leader in panel mounting hardware in the marine and architectural industry. They solve industry problems by staying close to the market and continuously innovating, delivering high value, high quality, niche product solutions.

We have been Fastmount's design partner for more than 10 years, in my presentation I will share the story of working with Fastmount, utilising a robust design process, staying ahead of innovation, and becoming a New Zealand manufacturing success story.



Ben Thomsen is a Founding Partner of Blender Design with a deep knowledge of design and manufacturing in New Zealand and internationally. Ben has a keen eye and technical focus with a unique problem-solving ability which has led to many successful and award winning products.

Findings from over 50 NZ manufacturer innovation diagnostic surveys

Presenting Author
 Packer, Adrian
 IMS-Projects
 Adrian.Packer@ims-projects.co.nz

New Zealand culture is very much characterised by ingenuity and innovation and we hear many examples of world class innovators coming out of NZ. However, our history of sustaining competitive advantage through innovation is not great:

- 97% of NZ businesses have less than 20 people and roughly a quarter of NZ businesses close within three years;
- New Zealand's expenditure on R&D as a percentage of GDP is only 52% of the OECD average;
- output per hour worked in New Zealand remains around 40% below the average of the OECD benchmark; a trend which continues to track downwards.

A distinguishing feature in New Zealand manufacturing is the small size (12%) of the medium-high technology sector compared to the equivalent sector in comparative countries (typically greater than 20%) and the apparent lack of appetite and / or capability to use innovation to sustain growth and profitability.

The key question for NZ manufacturers and MaDE2020 delegates is:
 What must NZ companies do differently to be leaders in manufacturing, design, and entrepreneurship?

In collaboration with Callaghan Innovation and HERA, IMS-Projects has surveyed over 50 NZ manufacturing, food processing and construction companies benchmarking their performance in six dimensions of the innovation management system. This benchmark has enabled businesses to target areas of focus and improve their innovation capabilities and outputs.

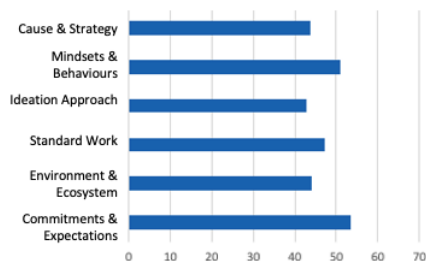

In this informative and data rich presentation we will show the results of the survey and share some practical case studies showing how NZ companies are succeeding by taking a systems approach to innovation.

Following the presentation MaDE attendees will be invited to complete the assessment and benchmark their own businesses against the other survey participants.

Adrian Packer has worked in business improvement for over 20 years. His areas of speciality include Lean, Innovation and performance coaching. He holds an MBA from Cranfield School of Management and a BSc Physics from the University of Bristol.

When an elephant walks into a room full of engineers: disjointed interpretation of innovation in engineering firms

Presenting Author
 Korber, Stefan
 The University of Auckland Business School
 s.korber@auckland.ac.nz

Husted, Kenneth
 The University of Auckland Business School
 k.husted@auckland.ac.nz

Siedlok, Frank
 The University of Auckland Business School
 f.siedlok@auckland.ac.nz

Innovation is widely recognised as a critical source of competitive advantage. At the same time, it remains one of the most elusive, misunderstood and misapplied concepts in academic and practitioner literature. Existing research has predominantly focused on output and process dimensions of innovation. Yet, little attention has been put on how innovation is understood and interpreted by individuals, teams and organisations in the first place. Drawing upon four case studies conducted with New Zealand based engineering project firms, we find that interpretations of innovation are shaped by institutionalised beliefs of professional groups, but also by macro-level narratives around emerging technologies, market disruption and innovation mindsets. Institutionalised assumptions, and associated practices and routines, lead to a narrow understanding of innovation and privilege incremental, and ad-hoc, forms. In turn, unreflective adoption of macro-level narratives, and related frameworks such as Design Thinking or Disruptive Innovation, pushes firms to pursue innovation either in a merely rhetorical (e.g., through vision statements) fashion or to focus on highly ambitious innovation projects that do not align with internal capabilities resources.

In turn, we call for a more reflective, contextualised and balanced application of innovation concepts. To translate innovation ambitions into reality, leadership needs to provide more clarity on what innovation means and what role it plays for the firm's overall objectives without relying on macro-level narratives in an uncritical manner. Understandings of innovation need to be aligned, communicated and supported by a clear innovation strategy and embedded in organisational structures and processes. Otherwise, innovation remains an elusive concept, much like the Elephant in the Indian fable where each blind man could only create his own version of reality (what an elephant is) from his limited experience and perspective.

Stefan Korber is a lecturer at the Auckland University Business School. His research interest includes Professional Service Firms, inter-disciplinary collaborations, and the influence of shared values and taken-for-granted assumptions on firms and social groups.

ATV tyre rolling resistance in agriculture

Presenting Author
Gooch, Shayne
University of Canterbury
shayne.gooch@canterbury.ac.nz

Petterson, Tim
University of Canterbury
tim.petterson@pg.canterbury.ac.nz

Electric vehicles are playing an increasingly important role in the New Zealand agricultural sector. The selection of tyres for reducing energy loss due to rolling resistance is an important consideration in determining the viability of these vehicles when compared to internal combustion equivalents. To date little is known about rolling resistance of small all-terrain vehicles, such as quads and side-by-sides. This study presents new data for rolling resistance of ATV tyres in an agricultural environment.

In this study, a test rig was towed across a Canterbury dairy farm, with rolling resistance data collected for seven ATV tyres. The study verifies the relationship between normal load and rolling resistance for the tested ATV tyres and gives insight into some of the important considerations when selecting tyres for small off road vehicles. It was found that an increase in tyre diameter had a significant impact on reducing rolling resistance, while excessive tyre width and tread depth were detrimental to tyre motion. Vehicle velocity was found to increase rolling resistance, even at low speeds (20km/h) due to the low operating inflation pressures of ATV tyres. An optimal inflation pressure exists for a certain combination of operational and environmental conditions, which minimizes rolling resistance.

A competitive, cost-effective EV cannot be developed without rolling resistance defined and minimized. This study provides important information for the selection of efficient tyres and the accurate determination of vehicle power and torque requirements.

Tim Petterson is a Master's student at the University Of Canterbury working on developing a small off road electric vehicle to perform tasks autonomously on a New Zealand dairy farm. He is supervised by Professor Shayne Gooch will present this abstract on his behalf since he could not attend MaDE2020.

Development of innovative cross-disciplinary engineering showcase

Presenting Author
Khanna, Jai
CEID, Waikato Institute of Technology
jai.khanna@wintec.ac.nz

Al-Rawi, Mohammad
CEID, Waikato Institute of Technology
mohammad.alrawi@wintec.ac.nz

Hartley, Carl
CEID, Waikato Institute of Technology
breen35@hotmail.com

The development of engineering education relies substantially on interactive showcases and practical knowledge. The cross-disciplinary engineering showcase is designed to be fully interactive by having user input, producing a tangible output, and to understand distinct elements from each of the engineering disciplines such as, civil, mechanical and electrical (CME). The showcase operates from the input of mechanical rotational energy by the user pedalling the exercycle. Mechanical energy is then transferred to the pump via a gear train, which converts the user input of 30 rpm to the optimal pump operating speed of 2900 rpm. Further, it is used to pump water from the lower reservoir to the upper reservoir via one of the three flow paths, which the user can select by opening or closing flow valves. Once the water reaches a given height, it then flows back to the lower reservoir via a micro-hydro generator. As a result, it generates electrical energy stored in a power bank that can be used by the user to charge a digital device. Also, the showcase has a QR code to digital media, which will provide an additional explanation/exposition of the presented engineering principles to the user/students. The aim of this project is to develop a cross-disciplinary engineering showcase to enhance student learnings by interpreting the CME engineering principles in schools, institutes and universities.

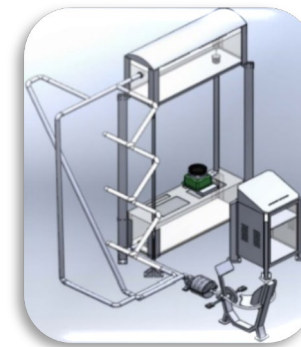

Jai Khanna is an academic staff member at Centre for Engineering and Industrial Design (CEID), Wintec. His research interest is in material science, manufacturing and design and he is currently developing innovative cross-disciplinary concepts for learners' engagement and enhancing engineering education.

Automated bandsawn plywood cladding prime and paint machine

Presenting Author
Al-Rawi, Mohammad
*Centre for Engineering and Industrial Design
Waikato Institute of Technology
mohammad.al-rawi@wintec.ac.nz*

Fangzhou, Ruan
*Waikato Institute of Technology
fanruao6@student.wintec.ac.nz*

Burley, Jordan
*Waikato Institute of Technology
jorburo8@student.wintec.ac.nz*

This design report proposes a solution for an automated linear paint spraying machine of band-sawn finish plywood sheets for TRICLAD, a Hamilton-based company looking to increase their output and quality control. The company wanted a solution that was cost-effective, environmentally friendly, and where possible, New Zealand made. There were already several automated spray-painting machines on the market, but none that TRICLAD felt suitably met their needs. The first part of this process looked into current systems available on the market and alternative ideas for paint application. As a result of this scoping process, it was decided that the base idea was to be a traditional type design, adjusted to meet the specific needs of TRICLAD. The design is illustrated in Figure 1 below. Due to cost and scale issues, a prototype was not built, but the proposed design may be prototyped in future. The proposed design employs mainly off-the-shelf items, for cost-efficiency reasons, and has been developed with flexibility and future add-ons in mind. From here, this design could be handed onto an automation company to refine and produce for use by TRICLAD.

The design used a range of ISO standard parts to ensure the accessibility of raw materials and components. The 304 stainless steel was selected as the core material. Compared to mild steel, stainless steel reduced the production time by saving processes such as coating and treatments. The frame of the machines can be either welded or bolted. The modular subcomponents are bolted for the ease of future maintenance.

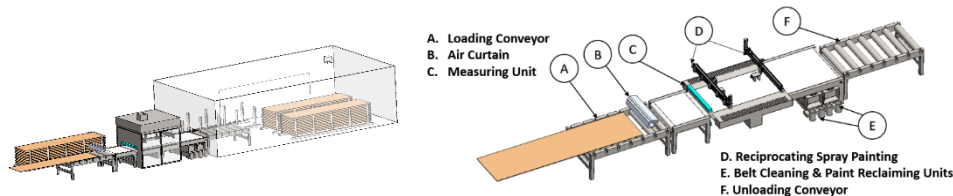

System Assembly

Core Components on the Automated Production Line

Mohammad AL-Rawi has a PhD in Biomedical Engineering from AUT (awarded in 2013). He is a Principal Academic Staff Member at Wintec's Centre for Engineering and Industrial Design (CEID). His current research is on improving air quality in residential environments. Interests include, applied computational modelling, design and advanced fluid mechanics and fluid power.

Glass-reinforced epoxy laminate electrodes for sensing applications

Presenting Author
Lal, Kartikay
*Massey University, Auckland.
k.lal@massey.ac.nz*

Arif, Khalid
*Massey University, Auckland.
k.arif@massey.ac.nz*

The world of sensors is growing at a rapid rate as the need for gauging physical phenomena in sensing applications becomes more in demand. Sensing covers a wide range of topics; from detecting variations in chemical reactions, such as changes in temperature or colour, to naturally occurring fluctuations, such as assessing humidity or CO₂ levels in the air. Decades ago, sensing was carried out on instruments, which were expensive and bulky. With the technological advancements, sensors today are lightweight, portable, easily manufactured and cost-effective. In recent years, thin-film or thin layer sensor electrodes have taken the realm of sensors/biosensors by storm, which are now very commonly used in detecting many physical world phenomena. These electrodes are usually fabricated in gold or silver because of their high electrical conductivity on substrates that are flexible like metal foil or polymer film or rigid like glass. These substrates are the most competitive and long-lasting for printing sensing electrodes.

A metal-foil can sustain high temperature, although, it has limited freedom of design and involves high cost. Glass substrate, on the other hand, is low cost but fragile in nature. For experimental purposes, polymer composites, such as glass-reinforced epoxy laminates (also known as FR4) have been used to detect resistance changes when dipped in various solutions ranging from deionized water to an ion rich solution, e.g. saltwater. The experiment was inspired by thin-film finger-like comb electrodes on non-flexible substrates such as glass slides, which are commonly used with microscopes in laboratories. The copper-clad FR4 boards were cut on LPKF PCB fabricator. The fabricator milled the finger-like electrodes on the copper surface on the FR4 board, which is about 150 μm in thickness, with approximately 30 fingers on each side of the comb. Three sets of comb electrodes were milled with finger pitch spacings from 8 mil up to 12 mil with 2 mil iteration. The electrodes were formed out of copper, which is a good conductor but prone to oxidization. Therefore the results may vary for every experiment carried out with water. Keeping this in mind, experiments were carried out with deionized water, normal tap water and varying levels of salt dissolved in water. The results showed a wider range of readings of resistance change in saltwater than deionized or tap water.

Kartikay Lal is a PhD student in the Department of Mechanical and Electrical Engineering, SF&AT, Massey University, Auckland. He holds a BE (hons) from Auckland University of Technology (AUT) and a Masters in Mechatronics from Massey University. He is a Massey Doctoral Scholar and his research interests include sensors, microfabrication, printed electronics and optics.

Fossils from the future

Presenting Author
Salter, Jessica
School of Design, Victoria University of Wellington
salterjess@myvuw.ac.nz

Guy, Bernard
School of Design, Victoria University of Wellington
bernard.guy@vuw.ac.nz

Stevens, Ross
School of Design, Victoria University of Wellington
ross.stevens@vuw.ac.nz

The future surrounding our world is unknown and difficult to foresee. There is a desire to communicate the innumerable amount of data produced from advanced scientific research about our present and predicted world into mediums that is comprehensible to the general public.

This research explores the opportunity for data to be translated into an easily interpretable visual and physical medium. By using a procedural system, this allows for an undetermined number of outcomes to be explored efficiently, including those of which that are initially unknown or cannot be perceived. This is in contrast to traditional 3D modelling software where the designer must have full control and manipulation of the finer details of a model.

In this research portfolio, a research through design methodology is utilised to enable practical experimentation based on a design criterion, incrementally developed alongside the progression of the experiments. Through screen-based visualisations, the possible products of a procedural system are presented as a morphological timeline. The designer's implementation and influence of this procedural system guide the direction of this timeline through parameter manipulation, without having a precise vision for the result.

Through extracting models at desired points along the morphological timeline and applying a voxel-based 3D printing approach on the Stratasys J 750 to encapsulate them in resin (VeroClear), the models are introduced to the tangible dimension. This translates the screen-based model into a physical fossil to communicate information through a tangible medium. These fossils intend to elicit discussion towards how possible products are produced that are not known or cannot be perceived. Acting as a viewpoint, the procedural system may visually anticipate these products before privileging the physical. Hence the 3D printed object is provided as a new spatial understanding to communicate information.



Jessica Salter studies a 'Master of Design Innovation' at Victoria University of Wellington. Her research explores the use of procedural systems and voxel-based 3D printing to create future fossils.

Continuous, high speed resin 3D printing by interface temperature control

Presenting Author
Collingwood, Jason
Massey University, Auckland
jasoncollingwood1@gmail.com

Arif, Khalid
Massey University, Auckland
k.arif@massey.ac.nz

This research investigates continuous high-speed resin 3D printing to answer the research question: 'Is the heat in the reaction of curing resin responsible for stiction in the cured resin to the substrate?' High-speed resin 3D printing has multiple benefits for the additive manufacturing industry, such as a better surface finish, increased strength and reduced printing times. This research is particularly aimed to benefit micro- and optofluidic research as these fields require very accurate, strong and complex components perfectly suited for continuous high-speed resin 3D printing.



Fig. 1- Interface temperature control 3DP system and printed samples.

By removing the heat in the substrate during digital light processing (DLP) 3D printing (as shown in Fig. 1), it has been found that continuous 3D printing is probable in a relatively inexpensive, and less complicated method compared to the technology currently available. The experimental system is able to continuously produce parts without slowly peeling them from the substrate as current DLP solutions require.

The results from the experiments are promising, however further investigations are needed to ensure that the hypothesis that the interface temperature control allows continuous 3D printing is correct. Similarly, only one resin has been used in the current experiments and more work with different resins is needed to see the impact of different resin characteristics on the systems' performance for continuous printing.

Jason Collingwood is a PhD student in the Department of Mechanical and Electrical Engineering at Massey University, Auckland. Jason holds a BE (hons) in Mechatronics from Massey University. His research interests include additive manufacturing, micro- and optofluidics, and robotics.

In-situ low power laser re-melting of Direct Metal Printed specimens for improved surface finish

Presenting Author
Pereira, Tanisha
Massey University
t.pereira@massey.ac.nz

Potgieter, Johan
Massey University
j.potgieter@massey.ac.nz

Kennedy, John
GNS Science
j.kennedy@gns.cri.nz

The rough surface finish of as-built Metal Additive Manufactured parts limits the industrial applications the manufacturing method can be applied to. The reduction of material used is one advantage offered by Additive Manufacturing, where subtractive tools can be used to smoothen the surface finish of a part. However, another advantage is designing complex geometries, which presents a problem in improving the surface finish; where subtractive tools cannot bend/access certain areas of the part. It has been proven that re-melting a metal surface, can improve the surface texture and finish with high laser power and varying speed.

This study analyses the effect of re-melting surface of a metal part with the low power laser within a DMP metal printer. The top layer of the printed specimen is hit with varying laser power, laser speed, layer pattern and repetitions. The main observation in the study is the part's change in surface roughness and stresses/deformations caused thermally. The reduction in post-processing outside the printer, the known location of the parts layers and shape for re-melting, is the main incentive in in-situ improvement of the surface finish. The affected specimens are examined using a RTD-210 Surface Roughness Gauge, Scanning Electron Microscopy and an in-situ thermography monitoring thermal camera.

Tanisha Pereira is a 3rd year PhD Student at Massey University. Her main area of research is in quality assurance strategies for Metal 3D printing, including; thermography, acoustic and ultrasound testing, and imaging.

Topology optimisation and generative design of products utilizing Selective Laser Melting

Presenting Author
Song, Daniel
The University of Auckland
hson558@aucklanduni.ac.nz

Diegel, Olaf
CDAM Lab
The University of Auckland
olaf.diegel@auckland.ac.nz

Schutte, Juan
CDAM Lab
The University of Auckland
juan.schutte@auckland.ac.nz

Topology optimisation and generative design are technologies that optimise the material layout in a given design space. The optimised model usually achieves lighter weight while keeping the functionality as required. These recent technologies have made an effect on how products are designed and manufactured.

Although both technologies share the same main goal of material reduction, their processes are still different from each other. Topology optimisation reduces the material of an existing model. Generative design defines the parameters and requirements that the imaginary product should satisfy, and its result is developed from an empty workspace. This research aims to determine the values of topology optimisation and generative design by applying both on the same products from various industries.

The Selective Laser Melting (SLM) technique will be used to manufacture the organic shapes with high complexity generated by topology optimisation and generative design. In contrast to conventional manufacturing, SLM is designed to use a laser to melt and fuse metallic powders layer by layer. This will also allow more accurate, rapid and cost-effective prototyping during the research.

This master's research will be completed in February 2021. The author has reduced the aeronautic parts' weight from 5.976 kg and 6.124 kg to 0.843 kg and 1.199 kg, respectively, by the change of material and topology optimisation. Both parts have passed the stress test simulation. Currently, the research is focusing on the testing and analysis of the generative design. The author will also conduct a cost-effective analysis to fill the lack of comparison between the performance of the same products utilising both technologies.

Daniel Song received a Bachelor of Honours degree in Mechatronics Engineering in 2019, and he is currently pursuing his Master's Degree at the University of Auckland. His thesis will focus on the cost-effectiveness analysis of topology optimisation and generative design of products utilising selective laser melting technologies.

Design and topology optimization of an autonomous driving shuttle body for additive manufacturing

Presenting Author
 Notoprodjo, Benedictus
 Massey University, Auckland
 benedictus.notoprodjo.1@uni.massey.ac.nz

Arif, Khalid
 Massey University, Auckland
 k.arif@massey.ac.nz

The design of a vehicle body plays a major role in ensuring the safety of passengers, especially when employing self-driving vehicles. However, advanced manufacturing capabilities of additive manufacturing have not yet been taken into consideration. Therefore, in this research, design and topology optimization for additive manufacturing of a fully electric autonomous driving shuttle body was performed.

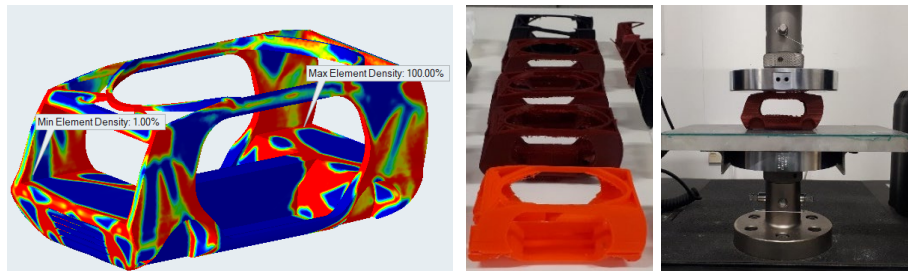

Fig. 2- Elemental density of the body design, scaled models, and compression testing.

Driving shuttle body design based on Interchangeable Modular Pod by Tesla was chosen. The body was modelled using SolidWorks and the topology optimizations and dynamic simulations were performed with SolidThinking Inspire software. The forces applied to the model were based on the actual operation and harsh environmental conditions. It was concluded that by observing the elemental density from topology an optimization solver, a lighter driving shuttle design could be achieved while maintaining the overall performance. However, only one optimization solver was used in the current research and more simulations with a different solver are needed to compare the impact of different optimization solvers on the model performance.

The final driving shuttle design was scaled before manufacturing with different orientations and properties. The samples underwent static testing to compare the performance under compression loading (as shown in Fig. 1).

Benedictus Notoprodjo is a research assistant in the Sensors and Smart Systems Lab at Massey University Auckland. He holds a Master's Degree in Mechatronics from Massey University and a Bachelor Degree in Mechanical Engineering from Bandung Institute of Technology. His research interests include finite element analysis, design optimization, and additive manufacturing.

Manufacturing hybrid composite parts using 3D printed continuous fibre reinforced polymers

Presenting Author
 Abdoli, Hamed
 Centre for Advanced Composite Materials (CACM), The University of Auckland
 hamed.abdoli@auckland.ac.nz

Bickerton, Simon
 CACM, The University of Auckland
 s.bickerton@auckland.ac.nz

Battley, Mark
 CACM, The University of Auckland
 m.battley@auckland.ac.nz

Diegel, Olaf
 CDAM Lab, The University of Auckland
 olaf.diegel@auckland.ac.nz

Composite materials are gaining popularity across multiple industries due to their high strength to weight ratios, high stiffness, and corrosion resistance. One major category of high-performance composite materials is fibre-metal laminates (FMLs), which are also known as Hybrid laminates. The manufacturing methods for FMLs was developed in the early 1980s, and the commercial standards are available for mass production. Examples of traditional composite manufacturing processes used to produce FMLs include Resin infusion Moulding (RTM), Hand Lay-up, and Vacuum Assisted Resin Infusion.

Additive Manufacturing (AM) technologies have advanced rapidly in recent decades, enhancing the process of bringing ideas into reality. Metal 3D printers have been developed as a tool to produce metal parts with highly complex geometry. More recently, AM technologies have enhanced the field of composites, with 3D printers of fibre reinforced polymers being introduced into the market. Solutions are available for short and continuous fibre reinforcement, providing for flexibility of design while reducing costs through elimination of moulds. The authors are exploring the combination of these technologies and in particular, the combination of metal, polymer and polymer composite 3D printing to manufacture hybrid composite parts.

This study is focused on direct printing of continuous fibre reinforced polymers onto a metal substrate. It is a challenge to join two or more materials cohesively, ensuring strong interfacial bonding in-situ during the manufacturing process. It has been demonstrated in the literature that the two main parameters affecting mechanical bonding strength are surface roughness and porosity. Initial results have demonstrated that presence of a porous layer on the substrate surface creates additional mechanical bonding with the resin. The long term aim of this research is a working unit cell in which a metal 3D printed part can be taken directly into a continuous fibre 3D printer, to create a hybrid component.

Hamed Abdoli is a PhD candidate at the Centre for Advanced Composite Materials (CACM) at the University of Auckland, working on novel composite manufacturing processes and inline quality measurement systems.

High-performance continuous fibre composite 3D printing: a process science-based approach

Presenting Author

Hares, Joshua

*Centre for Advanced Composite Materials (CACM), The University of Auckland
 josh.hares@auckland.ac.nz*

Bickerton, Simon

*CACM, The University of Auckland
 s.bickerton@auckland.ac.nz*

Kelly, Piaras

*CACM, The University of Auckland
 pa.kelly@auckland.ac.nz*

Battley, Mark

*CACM, The University of Auckland
 m.battley@auckland.ac.nz*

High-performance fibre reinforced plastics see widespread use across industries such as marine, automotive, and aerospace for lightweight, high strength and stiffness components. The manufacture of a component using current polymer composite manufacturing technology requires forming the part in a mould, incurring significant tooling costs, as well as the cost of the skilled manual labour required to laminate the part onto the mould. Automated Tape Layup and Automated Fibre Placement are recent technologies that are applied to automate composite manufacture, however they come with a range of their own limitations, and do not negate the need for a mould. Composite 3D printing of continuous fibre reinforced plastics is an emerging technology with the potential to both fully automate composite manufacture and remove the requirement of using a premade mould to form shapes. By incorporating continuous fibre reinforcement, significant improvements in mechanical properties are achieved, relative to polymers printed including chopped fibres. The technology has the potential to offer additional benefits, such as full 3D fibre steering, for highly optimised lightweight structures. While a few continuous fibre printing processes are commercially available today, applications are limited, as the resulting mechanical properties are significantly lower than those achieved using traditional manufacturing technologies.

A novel composite 3D printing process is being developed, which will have the ability to print carbon fibre thermoset polymers at a high fibre volume fraction, with mechanical properties comparable to traditionally manufactured composite materials. The approach used to develop this technology is based on fundamental process and materials science, which informs the ultimate design of the printing process. Fibre tows will be infiltrated in-situ, serving to minimise material costs. A modular prototype printing head will be constructed to test a range of variations on the process, as well as to demonstrate the capabilities of the composite 3D printing technology.

Joshua Hares is a PhD candidate in Mechanical Engineering at the Centre for Advanced Composite Materials (CACM) within the University of Auckland. His research is focused on the development of, and the process science surrounding, a novel composite 3D printing process.

Novel polymer material for wireless implantable sensors

Presenting Author

Blue, Simon

*University of Canterbury (Mechanical Engineering)
 sjb384@uclive.ac.nz*

Munro, Deborah

*University of Canterbury (Mechanical Engineering)
 debbie.munro@canterbury.ac.nz*

Current packaging choices for implantable wireless sensors have several limitations in terms of material selection, vapour permeability, biocompatibility, size, robustness, and lifetime. Packages based on metallic or ceramic enclosures guarantee mechanical and hermetic protection, therefore ensuring a long device lifetime, but they are limited in miniaturisation and flexibility. They are also opaque to electromagnetic waves, requiring the enclosed sensors to have battery sources of power and external antennae. Thus, universities and research institutions are exploring new polymer packaging materials to overcome these limitations.

The human body is a harsh environment: bodily fluids are highly conductive and contain many chemical and biochemical species that are potentially harmful to implanted electronic sensors. The packaging that encases the sensor directly interfaces with the body; therefore, it has to protect the sensor from bodily fluids while also protecting the body from any harmful effects from the sensor.

Polymeric packages, such as a liquid crystal polymer (LCP), offer mechanical flexibility, reduced size, weight and cost, biocompatibility, low vapour permeability, and hermetic seals. They can be injection moulded and are transparent to electromagnetic waves. This transparency allows for the transmission of wireless signals and/or power to an external device. However, LCP still has some drawbacks preventing its adoption for long-term applications. Although LCP has a low moisture absorption rate, the moisture from the human body will eventually pass through the packaging material, affecting the operation of the implanted electronic sensor.

Our research goal is to increase the lifetime and robustness of a polymer-based packaging technology that could provide an increased usable lifetime for an implanted sensor. This research investigates using particulate deposition techniques, such as sputtering, to incorporate a thin impermeable metal membrane to improve the moisture barrier performance of an LCP package. Moisture ingress is monitored with a wireless, internal relative humidity sensor.

Simon Blue is a research assistant for Dr Deborah Munro, Mechanical Engineering Senior Lecturer at the University of Canterbury. She leads the Minor in Biomedical Engineering. Half of her career was in the industry, designing orthopaedic implants and medical devices. Her current research is on wireless sensors for measuring fracture healing.

Micro-contact printed, self-assembled pattern-based arsenic detection

Presenting Author
Jaywant, Swapna A.
Massey University
s.jaywant@massey.ac.nz

Banerjee, Pinky Mal
Massey University
pinkymal1985@gmail.com

Arif, Khalid
Massey University, Auckland
k.arif@massey.ac.nz

Water contamination is one of the current global issues; the freshwater sources being extremely restricted are causing a drinking water crisis in many countries. An increase in water contamination continuously decreases water quality. The various natural sources such as precipitation, weather, basin physiography, soil erosion and man-made sources like urbanization, industrial and agricultural activities, etc., are responsible for water pollution. Generally, water pollution includes pathogenic, nutrients, and chemical (organic & inorganic) contaminants. Inorganic contamination involves metallic particles such as arsenic, lead, etc. Of these contaminants, arsenic (As) is a major concern due to its mutagenic and carcinogenic effects on human health.

We present a novel sensor with unique surface modification technique to detect dissolved arsenic contamination of water by measuring the density of immunomagnetic beads. It features self-assembled patterns of thiol ligand like glutathione (GSH) on the gold-coated glass. Thiol can easily bind with gold and As(III) has an affinity towards thiols. Hence, GSH binds with gold-coated glass and arsenic. The patterns are obtained through a micro-contact printing (μ CP) procedure. When these patterns are exposed to arsenic-contaminated water, the arsenic layer forms on the GSH pattern. Followed by the signal enhancement with the aptamer-based sandwich assay for arsenic detection with the help of image processing method. Our findings suggest that the proposed method can also be used for detection of a variety of other metallic and pathogenic contaminants like E. coli for water quality monitoring.

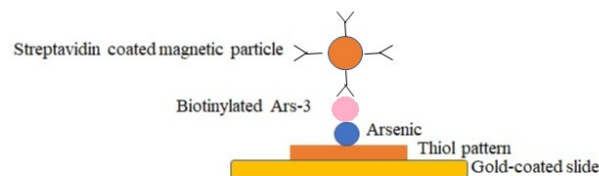

Fig. 1 Aptamer- based sandwich assay for arsenic capture.

Swapna A. Jaywant recently completed her PhD in Engineering at Massey University. Currently, she is working as a research associate in the Sensors and Smart Systems Laboratory at Massey University Auckland. Her areas of research interests include sensing technology, microfluidics, bioinstrumentation, and additive manufacturing.

Influences of ambient temperature on sintering of biodegradable polylactic acid (PLA) used in Fused Deposition Modelling (FDM)

Presenting Author
Ameer, Adel
University of Waikato
aaa45@students.waikato.ac.nz

ChiKit, Au
University of Waikato
chikit.au@waikato.ac.nz

Carson, James
University of Waikato
jkcarson@waikato.ac.nz

Fused deposition modelling (FDM) innovation is one of the popular methods for fabricating functional parts. The advantage of this technique is to build a complex geometrical shape in a single setup without human interventions. However, the mechanical properties of the thermoplastic materials used are low compared to those of other engineering materials; the bonding quality (sintering) among filaments determines the mechanical properties of the fabricated FDM part.

The objective of this work is to determine the influence of the ambient temperature on the sintering process. An experimental study on polymer sintering has been conducted for two samples; one extruded at room temperature and the other at higher ambient temperature. From the results it is evident that the samples extruded at high ambient temperature had a better bonding quality during sintering. A series of 3D printed samples were subjected to the three-point bending flexural test. Results showed that the parts fabricated using the filaments produced at higher ambient temperatures had significantly higher flexural strength compared to the parts fabricated at the average temperature with the magnitudes of 57.12 MPa and 53 MPa respectively.

This research positively impacts NZ design and manufacturing processes. 3D printing has great potential in the medical field particularly in human orthopaedics, dentistry and surgery procedures.

Adel Ameer is a PhD candidate in the Mechanical Engineering Department at Waikato University. Her areas of research interest are Manufacturing of Modelling, CAD and Additive Manufacturing.

Characterisation of the relationship between hydrogel properties and 3D printing parameters

Presenting Author

Ishii, Melissa

University of Canterbury (Mechanical Engineering)

melissa.ishii@pg.canterbury.ac.nz

Munro, Deborah

University of Canterbury (Mechanical Engineering)

debbie.munro@canterbury.ac.nz

With technological advancements in rapid prototyping and 3D bioprinting, biocompatible hydrogel materials known as 'bioinks' can now be fabricated using these emerging technologies. Traditionally, scaffolds for tissue engineering were produced using moulds which allowed for very little control over the microstructure and overall anatomy. By utilizing additive manufacturing principles, biomaterials and cells can be precisely deposited in a layer-by-layer fashion to produce scaffolds.

Bioprinters have many adjustable parametric settings that affect the printability of a material. However, little is understood about the optimal parameters to print a wide range of these bioinks. Currently, anytime a novel bioink is created there is a process of trial and error that is required in order to determine the optimal printing parameters for the bioprinter and desired application.

Though bioprinters are a very useful tool for many researchers, the usage is limited due to the discovery process required to optimise the printing parameters for each new material. If an established method existed to determine optimal printing parameters, this would make the technology more accessible for groups who do not study 3D fabrication as part of their research interests. Additionally, more studies could to move from 2D environments to more biologically relevant 3D cultures.

Our research aim is to characterise the relationship between rheological properties and printability of various bioinks. Then, by drawing connections between the material properties and the printing parameters, an established protocol will be developed for a range of materials. The viscoelastic and shear-thinning properties of the hydrogel will be measured using rheological studies pre and post gelation, so the shear and storage moduli can be calculated.

Melissa Ishii is a postgraduate student at the University of Canterbury supervised by Dr. Deborah Munro. Melissa's research interests include the use of 3D printing to manufacture tissue scaffolds for the repair of spinal cord injury and axonal propagation. She holds a Bachelor in Mechanical Engineering from the University of Portland and a MSc in Bioengineering from Imperial College London.

Protein-based biomaterials for 3D & 4D printing

Presenting Author

Agnieray, Heiana

The University of Auckland

hagn953@aucklanduni.ac.nz

Kaur, Manmeet

The University of Auckland

manmeet.kaur@auckland.ac.nz

Workman, Josh

The University of Auckland

j.workman@auckland.ac.nz

Domigan, Laura

The University of Auckland

l.domigan@auckland.ac.nz

Gerrard, Juliet

The University of Auckland

j.gerrard@auckland.ac.nz

The growing field of three-dimensional (3D) and four-dimensional (4D) printing is receiving particular attention due to its process flexibility and versatility. Along with the rapid growth of 3D and 4D printing applications, corresponding printable materials are in high demand and have become an intensive research area in the last decade. Various biological polymeric materials, including collagen, gelatin, hyaluronic acid, silk and so on, have been investigated as the main components of biomaterial inks by several research groups. Despite the abundant work on the development of biomaterial inks, the field is still struggling to develop biomaterial inks that satisfactorily meet bioprinting requirements, such as tuneable mechanical, rheological, and biological properties.

To address this issue, we are investigating whey protein isolate (WPI) – a by-product of cheese manufacturing as a biomaterial ink. Well-established gelation properties and abundant availability make WPI particularly interesting for this application. Furthermore, the quaternary structure of the main component of WPI, β -lactoglobulin, can be converted from its native globular form to long-stranded fibrils, under specific conditions. Thus, allowing us to modulate mechanical and rheological properties based on different quaternary structures of the same protein. The material (WPI-MA) is created by the methacrylation of WPI using glycidyl methacrylate. The material is then permanently crosslinked to obtain hydrogels via the process of photopolymerization, in the presence of a photo-initiator. The mechanical properties of the developed WPI-MA hydrogels can be adjusted by changing the protein content within the ink or by changing WPI-MA concentrations, with increasing concentrations correlating to increased Young's modulus of the cured hydrogel. Additionally, the WPI-MA hydrogels exhibit thermal and pH-responsive behaviours. Ultimately, the preliminary 3D printing results of WPI-MA demonstrate the promising printability of the material. As future work, mechanical and rheological properties will be explored further, along with cytotoxicity studies to demonstrate the biocompatibility of WPI-MA.

Heiana Agnieray is a PhD student at the University of Auckland. She holds a bachelor's degree in chemistry, a post-graduate diploma in food science (Merit) and a master's degree in chemistry (First-class honours). She is interested in protein chemistry, biomaterial development and additive manufacturing.

Assessing the design of bone interfacing additive manufactured titanium medical devices via imaging

Presenting Author

Baer, Kenzie

Christchurch Regenerative Medicine and Tissue Regeneration (CReaTE), Dept of Orthopaedic Surgery, Centre for Bioengineering & Nanomedicine, University of Otago, Christchurch
kenzie.baer@postgrad.otago.ac.nz

Amma, Maya Rajeswari

University of Otago, Christchurch
MARS Bioimaging Ltd, Christchurch
maya.rajeswari@marsbioimaging.com

Raja, Aamir

University of Otago, Christchurch,
MARS Bioimaging Ltd, Christchurch
aamir.raja@otago.ac.nz

Woodfield, Tim

CReaTE, University of Otago, Christchurch
tim.woodfield@otago.ac.nz

Imaging bone growth in and around additively manufactured (AM) titanium implants and medical devices is critical for “design for AM” strategies and clinical assessment of implant performance. Standard clinical computed tomography (CT) imaging of titanium and bone is challenging given that titanium creates significant artefacts, making it difficult to differentiate bone and titanium. Photon-processing spectral CT, a novel imaging technique, has been shown to reduce image artefact from titanium using a high energy binning technique. This study aimed to quantify calcium in and adjacent to solid and porous titanium implants to assess image artefact reduction techniques and measure calcium content information as a surrogate for bone.

A titanium surgical screw and porous electron beam melted (EBM) titanium alloy scaffold were submerged in five CaCl_2 concentrations and scanned using photon-processing spectral CT with five energy bins. Quantification of calcium was measured in and adjacent to implants. Titanium screw was also implanted into an ovine femoral bone to determine image artefacts on bone parameter values.

The linearity of calcium’s attenuation in each energy bin established that photon-processing spectral CT functions as five monochromatic beams, significantly reducing beam hardening artefact. Calcium concentrations outside the scaffold were accurately quantified whereas those inside the implant were overestimated, likely due to streak artefacts and partial volume effects. Bone parameters in the ovine femur were similar with and without the screw present. Reducing artefacts around AM titanium implants and quantifying surrounding bone represents a significant advancement in evaluating the effectiveness of AM implant integration capacity; thus allowing assessment of performance parameters to drive AM implant design process.

Kenzie Baer is a PhD student with a background in biomedical engineering, researching photon-processing spectral CT imaging of tissue quality through disease, regeneration and around implants.

Electrospinning of protein nanofibers

Presenting Author

Chen, Qun

Department of Chemical and Materials Engineering
The University of Auckland
qcheo98@aucklanduni.ac.nz

Domigan, Laura

Department of Chemical and Materials Engineering
The University of Auckland
l.domigan@auckland.ac.nz

Kaur, Manmeet

Department of Chemical and Materials Engineering
The University of Auckland
manmeet.kaur@auckland.ac.nz

Travas-Sejdic, Jadranka

School of Chemical Sciences
The University of Auckland
j.travas-sejdic@auckland.ac.nz

Amyloid fibrils, formed by structurally re-arranged proteins or peptides, are historically associated with human diseases. However, they have now been identified as a source of new materials. Their unique protein nanofiber structure of cross-beta sheets enables them to be strong and stable building blocks, and they have been studied in a variety of applications such as biosensors, nanowires, and cell scaffolds. Protein nanofibers can be constructed from a number of low-cost proteins that are common in the lab, and also from industrial protein by-products. In this work, we are using bovine haemoglobin, a low-value by-product of the meat industry, as an economical protein nanofiber source. After electrospinning with polycaprolactone (PCL, a common polymer biomaterial), a thin mat was successfully produced. The presence of protein nanofibers in the mat was confirmed by thioflavin T fluorescence assay and preliminary results also showed good cellular biocompatibility. This work indicates the feasibility of incorporating protein nanofibers in new materials, which may have better mechanical performance or programmable functions. Further work will explore the use of functionalised protein nanofibers (e.g. small molecules), and the utilization of other manufacturing techniques (e.g. additive manufacturing). This study encourages the use of industry waste proteins, such as bovine blood, as a source material to create functional protein nanofibers and their application.

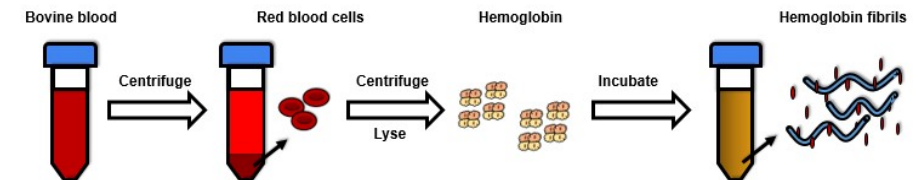

Qun Chen is a first-year PhD student in the Department of Chemical and Materials Engineering at the University of Auckland. She received a Bachelor’s degree in Biological Sciences from Jilin University and a Master’s degree in Biological Sciences from the University of Auckland. Her interests are proteins and biomaterials.

Development of a sheep knee finite element model to optimise the design of additive manufactured implants

Presenting Author
Shum, Josephine

*Christchurch Regenerative Medicine and Tissue Engineering (CReaTE), Department of Orthopaedic Surgery and Musculoskeletal Medicine, Centre for Bioengineering & Nanomedicine, University of Otago Christchurch
josephine.shum@postgrad.otago.ac.nz*

Fok, Wilson
*Auckland Bioengineering Institute
The University of Auckland
wfokoo7@aucklanduni.ac.nz*

Fernandez, Justin
*Auckland Bioengineering Institute
The University of Auckland
j.fernandez@auckland.ac.nz*

Tredinnick, Seamus
*CReaTE, University of Otago, Christchurch
seamus.tredinnick@otago.ac.nz*

Woodfield, Tim
*CReaTE, University of Otago, Christchurch
tim.woodfield@otago.ac.nz*

Sheep are commonly used as pre-clinical models to investigate the design and evaluation of orthopaedic implants and surgical strategies. Little effort has been concentrated on developing sheep finite element models (FEM) to streamline biomechanical research through *in silico* analysis. The purpose of this investigation was to develop a FEM of the ovine stifle in order to reliably and efficiently predict *in vivo* stress and strain of orthopaedic implants in a tibial tuberosity advancement (TTA) model. Through additive manufacturing (AM), porous titanium-alloy scaffolds can be fabricated with the desired mechanical properties and anatomically informed geometry, creating optimised AM implants to support early bone formation.

The model was developed using CT data to generate the skeletal anatomy of the sheep stifle, including physiological material properties. A bed of springs was modelled at the tibiofemoral contact patch to simulate the load-transferring capabilities of cartilage. Model position, angle and muscle forces were taken from literature to exhibit the peak axial load during gait. The model was then morphed to reflect the modified anatomy post-surgery, incorporating the desired AM implant geometry. Lastly, a tension band plate and four screws were incorporated to emulate the exact TTA surgical approach. FEA demonstrated that AM implant designs with a locally optimised stiffness, rather than homogeneous stiffnesses, had a greater region (13%) of the implant supporting the target strain range reported to improve bone formation. It is also common for tibial crest fracture to occur after a TTA procedure; when this scenario was modelled, the increased stresses did not affect the mechanical integrity of the implant, but did predict a 2% increase in the desired strain range of the implant.

In conclusion, FEA could be an effective tool to inform the design pathway of AM titanium implants, leading to better patient-specific treatments.

Josephine Shum is a PhD candidate with a background in Mechanical Engineering, researching how to optimise 3D printed scaffolds to encourage bone-to-implant integration for orthopaedic applications from conception to design and manufacture all the way through to implantation.

Adhesively bonded metal-composite structures for aircraft interior applications

Presenting Author
Xu, Shuo

*Auckland University of Technology
shuomk23@gmail.com*

Schaefer, Marcel
*Auckland University of Technology
marcel.schaefer@aut.ac.nz*

In this project, we explore metal-composite joints (T6061 aluminium alloy and T700 Carbon Fibre Reinforced Polymer (CFRP) for aircraft's interior applications. The hybrid structure is used to support a flight attendant seat. The primary purpose of developing this new metal-composite hybrid structure is to reduce weight in a cost-efficient context.

A demonstrator of adhesively bonded Aluminium-CFRP hybrid structure is built and tested to determine the feasibility of these aluminium-CFRP hybrid joint structures and if they can compete with existing aluminium structures in aircraft interior applications. The CFRP components are bonded to aluminium joints by high-performance adhesives. The epoxy adhesive (or thermoplastic adhesive) is designed for structural metal and composite bonds, such as metal to metal parts, metal to composite parts and composite to composite parts. Adhesive bonds can provide improved fatigue performance due to the ability to achieve a uniform stress distribution in the joint. Further, manufacturing advantages can be achieved as large structures do not need to be manufactured to tight tolerances.

This proposal illustrates the feasibility test for exchanging aluminium structures by aluminium - CFRP structures for aircraft interior applications. There will be structural tests performed to replicate the operational boundary conditions. Indeed, the main objective of these tests is to determine if the proposed solution can outperform the expectations experienced under operational conditions.

Shuo Xu is a Master's student at Auckland University of Technology and his research area of interests are mechanical design, product development, CAD, manufacturing technologies and composite material applications. His current research topic is related to adhesive-bonded metal-composite structures for aircraft interior components and adhesive performance.

A smart monitoring platform for machinery health management in the framework of Industry 4.0

Presenting Author
Choudhury, Madhurjya Dev
The University of Auckland
mcho491@aucklanduni.ac.nz

Hu, Roger
The University of Auckland
rh955@aucklanduni.ac.nz

Blincoe, Kelly
The University of Auckland
k.blincoe@auckland.ac.nz

Dhupia, Jaspreet Singh
The University of Auckland
j.dhupia@auckland.ac.nz

Machinery health management is necessary to avoid premature machine failures in order to ensure permanent plant availability, which in turn impacts the economic health of the manufacturing sector. It is noteworthy that this sector alone contributes around 12-15% to New Zealand's annual GDP. A recent trend in manufacturing and service sectors, referred to as Industry 4.0, emphasizes "smartness" through data exchange within different machines and components. An important aspect of this data exchange occurs when monitoring the health of a machine, using sensors mounted on the machine whose measurements need to be analysed in real-time, relevant health parameters automatically identified, and the fault information stored for appropriate maintenance actions.

This work discusses the design of a machinery monitoring system and incorporate it in the Industry 4.0 framework by developing a proof-of-concept online application for real-time monitoring of industrial assets. The proposed work is based on extracting robust health indicators (like RMS, Kurtosis etc.) from the vibration signals acquired from machine components under observation, using advanced signal processing techniques. A smartphone app is developed as a framework to visualize the time-series data and the health indicators of any monitored machine in real-time and receive alarms and notifications in case of any anomalies, which is determined by setting a pre-defined threshold. The outcome of this work will provide an integrated framework to the users facilitating them to continuously monitor the indicators, which are representative of the level or severity of failure in any machine element, and plan the maintenance of the equipment, prior to any impending failure event.

Madhurjya Dev Choudhury is pursuing his PhD in the area of condition monitoring and fault diagnosis at the University of Auckland.

Augmented Reality-enabled machine maintenance for Cyber-Physical Machine Tools

Presenting Author
Zhu, Zexuan
The University of Auckland
zzhu827@aucklanduni.ac.nz

Xu, Xun
The University of Auckland
xun.xu@auckland.ac.nz

Cyber-Physical Machine Tools (CPMT) represents a new generation of machine tools that are smarter, well connected, widely accessible, more adaptive and more autonomous. CPMT could effectively collect all the information through the lifecycle of the machine tool, and this information should be utilized by different users under different scenarios and on different purposes. As an effective approach to present the information and data from machine tools, augmented reality technology (AR) has been introduced into the manufacturing field for strengthened information in real-world scenarios through the integration of virtual information with physical world, and it has been approved as an efficient and intuitive method to present the information to different users.

Downtime is a significant factor that hinders the attainment of manufacturing efficiency. Therefore, the appropriate machine maintenance could effectively reduce the unexpected downtime and cost. AR technology has been widely applied into the maintenance related field to lower the difficulty of maintenance, reduce maintenance errors, and improve maintenance efficiency and quality. Applications could include remote maintenance, AR-assisted machine manual, etc. All these proposed applications are only capable of supporting the technician in one direction, without getting any feedback from technician. As such, the subsequent maintenance process may be delayed. Therefore, this study focuses on providing a solution for this problem.

The proposed system allows a technician to make use of information and data through AR technology to make decisions. The Machine Tool Digital Twin (MTDT) will also cooperate with technician to provide appropriate information to corresponding users, such as placing order, shop-floor scheduling, logistic information, etc. It will further improve the maintenance efficiency and reduce the unexpected downtime and cost.

Zexuan Zhu pursued his PhD study at the University of Auckland since 2018. He joined the LISMS research group under the supervision of Professor Xun Xu in Mechanical Engineering. His research areas include smart manufacturing, Augmented Reality (AR) in manufacturing, Cyber-Physical System (CPS) and Digital Twin technology.

Retrofitting strategy for manufacturing systems to Industry 4.0 standard

Presenting Author
Malvar, Dylan Luther
Auckland University of Technology
dl_malvar1995@yahoo.com.ph

Schaefer, Marcel
Department of Mechanical Engineering
Auckland University of Technology
marcel.schaefer@aut.ac.nz

Industry 4.0 has provided the manufacturing industry new paradigms in analysing manufacturing processes. Retrofitting strategies introduced quality monitoring which involves data loggers and remote monitoring using cloud servers. The previous strategy opened the possibility of remote access to areas which are not accessible to humans inside the machine and improved quality of work inside the production line. The strategy was effective but came with a high investment as millions of dollars were spent to implement the entire systems. The technology Industry 4.0 may only be accessible to large enterprises which will leave small to medium enterprises (SMEs) left behind.

The plan for this project is to introduce a retrofit strategy that will show SMEs that tapping into Industry 4.0 solutions will not involve investments of millions of dollars and show capabilities of sensors and diagnostic tools. Vibration sensors will be installed in areas near the linear bushings and Temperature sensors will be installed on motors and would show condition-based monitoring with the help of data analytics and cloud-based storage. The aim is to predict adverse vibration and temperature patterns in order to plan maintenance schedules and component failures and improve productivity.

The strategy also shows the capabilities of Data Analytics, Internet of Things and Cloud Computing in the improvement of machines. Data analytics provides small firms insight on maintenance planning for the future as prediction graphs are used to show real-time processes and patterns for the motors and linear bearings. Cloud Computing provides small firms of online storage of data for future use that can be shared to other stakeholders and Internet of Things proves the fast connectivity of sensors to diagnostic modules. Therefore, the Industry 4.0 retrofit strategy can be implemented by small companies without a substantial investment burden.

Dylan Luther Malvar is a final year Undergraduate Mechatronics Engineering Student at Auckland University of Technology. His research interests include aerodynamic materials, manufacturing processes, data process analytics and cloud computing.

Innovating in the age of AI, an exploration of human-AI cooperation in international business

Presenting Author
Yan, Jitao
The University of Auckland
mario.yan@auckland.ac.nz

Husted, Kenneth
The University of Auckland
k.husted@auckland.ac.nz

Brache, Jose
The University of Auckland
jose.brache@auckland.ac.nz

Artificial intelligence (AI) has emerged as an important and increasingly growing area of scholarly inquiry. However, an in-depth discovery of its implications in contemporary organizations remains insufficient. Some studies posit that the technological revolution driven by AI technology will stimulate new levels of value creation and change the business dynamic globally. AI's contributions to business innovation lie in its capabilities to accelerate innovation strategy development in conjunction with human effort.

Prior research embracing this emerging area of study is scant. Existing studies have contributed to this realm by establishing linkages between AI and firms from a few perspectives, for instance, innovation on knowledge management, marketing and business model. However, a research gap exists regarding the incorporation of AI in the innovation process of the international business firm. Therefore, a conscientious investigation of this phenomenon is imperative. The purpose of this research is to establish and articulate the relationship between AI, innovation and firm internationalization. Moreover, it is to examine the catalytic effects of AI in innovation and knowledge creation processes in AI-driven enterprises.

This research employs a qualitative methodology. A dedicated firm-level analysis for this research is appropriate because it allows researchers to probe into the focused AI-driven organizations through interviewing managers who steer the internationalization phenomenon while being directly involved in the AI-enabled innovation process.

The contributions of this research are to shed light on how firms embrace the usage of AI inventions and further transform them into competitive advantages on their path to internationalization. This study will also raise managerial awareness and offer managerial and public policy implications in the hope to deliver profound insights and knowledge to advance prospective business practices.

Jitao Yan is a PhD candidate in the department of management and international business at The University of Auckland's Business School. His current research is focused on exploring the extent to which AI can support innovation and new knowledge creation, thus leading firms to further growth internationally.

Development of an Operation Management System (CP-OMS) for Smart Factories

Presenting Author

Hamzeh, Reza

Mechanical Engineering Department
The University of Auckland
reza.hamzeh@auckland.ac.nz

Xu, Xun William

Mechanical Engineering Department
The University of Auckland
xun.xu@auckland.ac.nz

Due to the recent advancements in Information and Communication Technologies (ICT) in the current interconnected world, manufacturing enterprises are becoming more data rich. An enormous volume of data is generated on shop floors every day, hour, or even second, thereby presenting new opportunities to manufacturing companies. These opportunities need to be explored with the aim of improving the flexibility, efficiency, and quality of production systems and establishing factories: future so-called Smart Factories.

As the backbone of Smart Factories, intelligent manufacturing systems aim to improve the manufacturing processes through a combination of concepts such as the Industrial Internet of things (IIoT), Cyber-Physical Systems (CPS), Machine Learning, and big data analytics. The application of these technologies and the process of collecting, analysing, and manipulation of the generated data from manufacturing shop floors introduces a new set of challenges to manufacturing companies.

A project called Cyber-Physical Operation Management System (CP-OMS) was established, focusing on addressing these challenges. First, a set of requirements for building big data pipelines in Smart Factories are identified. Next, a cloud-based system was developed to facilitate the collection, integration, and analysis of generated data from a shop floor. An industrial testbed was then developed to examine the effectiveness of the proposed system. The results show significant improvements in management and analysis of industrial big data in the manufacturing industry.

Reza Hamzeh joined the Laboratory for Smart Manufacturing Systems (LISMS) in 2017 and since then he has been pursuing his PhD in Mechanical Engineering at the University of Auckland. His research involves the Industrial Internet of Things, Process Optimization, and Technology Management.

COMFlex designer: physical interaction and immersive visualisation with virtual products

Presenting Author

Ritchie, Annabelle

University of Canterbury
ari49@uclive.ac.nz

Kennelly, Sarah

sek40@uclive.ac.nz

Topliss, Jack

jto63@uclive.ac.nz

Bontilao, Joselle

jdb139@uclive.ac.nz

Dunn, Jessica

jdu56@uclive.ac.nz

Renaud, Andre

andre.renaud
@canterbury.ac.nz

Huber, Tim

tim.huber
@canterbury.ac.nz

De Gast, Barro

barro.degast
@canterbury.ac.nz

Piumsomboon, Tham

Tham.piumsomboon
@canterbury.ac.nz

The purpose of this work is to enhance product designers' experiences and make the process of product design less time consuming and expensive. Although virtual tools for product designers exist, they lack physical interaction, which is crucial for providing tangibility to designs. This means that physical modelling, materials and tools are usually required once the virtual model has reached a certain level of fidelity. This can be time and resource consuming as for each iteration an entire reproduction must be created. This paper presents a VR system, the COMFlex designer, which offers a handheld physical representation of products during the design process. Haptic feedback in the form of a weight distribution changing (COM) and shape-changing (Flex) device is offered while the designer observes a visual representation of their product in VR. Any changes the designer makes to their product is reflected by the COMFlex designer system, allowing live dynamic feedback from the product to the person.

The designed product shape is represented by a glove-like mechanical device (the Flex) which contains stiff plastic plates that move to restrict the user's finger flex as they hold an object in

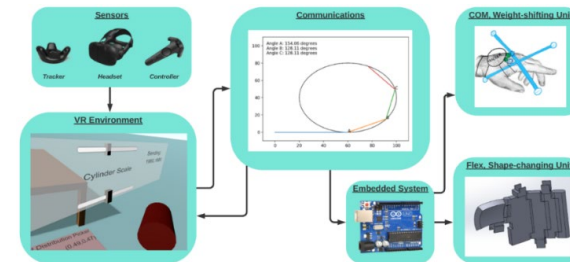

the virtual environment. The product's centre of mass (the COM) is represented by a mechanical device that allows weights to be moved to any position along two axes, supporting various weight distribution co-ordinates. An embedded system running on Arduino controls the stepper and servo motors controlling the

COM and Flex devices respectively. A communication system supports sending Bluetooth messages from a virtual environment to Arduino, and this virtual environment is linked to VR, containing controls for changing the weight distribution and shape of the COMFlex designer.

Annabelle Ritchie has just completed her bachelor's degree in computer engineering at the University of Canterbury. Her research interests lie in Human-Computer Interaction, particularly in haptics and their interaction with virtual reality.

Reconditioning FESTO manufacturing machines for use with Rockwell automation equipment

Presenting Author
Chand, Praneel

Waikato Institute of Technology (Wintec)
praneel.chand@wintec.ac.nz

Sepulveda, Joven

Wellington Institute of Technology (WelTec)
jvnsepulveda@gmail.com

Equipment such as programmable logic controllers (PLCs) become outdated and obsolete over time. Support for older devices becomes limited and they become incompatible with new computer operating systems. In the end, they are no longer used by industry. Hence, this project considers reconditioning a FESTO manufacturing machine by replacing the old PLC with a Rockwell PLC so that it's compatible with the mini industrial network in the mechatronics lab. This upgrade allows the machine to be used for student training in the automation courses.

Specifically, the FESTO MPS Storage and Retrieval machine is refurbished. The machine has three axis electromechanical gantries, a gripper, DC motors with encoder feedback, reed switches, and a pneumatic actuator. The IO connection from these components to the old PLC is traced and a new interface to the Rockwell PLC is established while keeping connectivity with the old PLC for legacy control.

After designing the new interface, some test programs were made in RS Logix 5000 using the Ladder Diagram (LD), Sequential Function Chart (SFC), and Structured Text (ST) languages. The machine was able to execute an automatic sequence of pick and place operations successfully. Future work will include designing a FactoryTalk View HMI and integrating the FESTO machine with other machines in the lab.



FESTO MPS System



Storage and Retrieval Machine

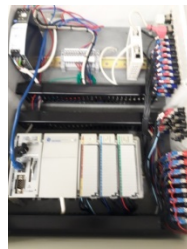

Allen-Bradley PLC

Praneel Chand is a Senior Academic Staff Member in the Centre for Engineering and Industrial Design (CEID) at Wintec. He holds a PhD in Electronics and Computer Systems Engineering from Victoria University of Wellington. Praneel's research focuses on the design and development of electronic and computer systems for control, automation, mechatronics, and robotics problems.

Human Capital 4.0: competences and skills for disruptive challenges

Presenting Author
Flores, Emmanuel

The University of Auckland
ntoro30@aucklanduni.ac.nz

Xu, Xun

The University of Auckland
xun.xu@auckland.ac.nz

Now more than ever before, there is a need to look deep into the study and research of human competencies, for they are the underpinning keystones for human performance. The current disruptive time forces society and companies to learn to adapt, not only to survival but also for future thriving. Thus, in this poster, we will present our research results so far in three summarised ways. First, we created a self-proposed researched model of human competences and critical considerations for the new Human Capital 4.0 era. A typology-competence of five primary skills, i.e., Soft, Hard, EI, IQ, Digital, is shown. Second, we have proposed a reference architecture model for the education/training of such competences at different stages and levels of the life of individuals, i.e., age and personal zones. Third, we have identified the difference between humans and machines 'skills' and have hightailed the main differentiator according to up-date practices of automation, i.e., intelligence/consciousness. Our research aims to support the upskilling and re-education of people and the workforce to embrace better and adapt Industry 4.0 vision, or any other challenging event, i.e., the Covid-19 situation.

Emmanuel Flores is pursuing a PhD at the University of Auckland (Nov-2017 – Oct.2021). He is under the supervision of Prof. Xun Xu in the Department of Mechanical Engineering, and his research interests include Industry 4.0, Operator 4.0, Human Capital, Human wellbeing and Social wellbeing.

Presenter Index

PRESENTING AUTHOR	ORGANISATION	PAGE
Abdoli, Hamed	The University of Auckland	121
Abdolmaleki, Sahar	University of Otago	88
Agneray, Heiana	The University of Auckland	127
Al-Rawi, Mohammad	Waikato Institute of Technology	114
Ameer, Adel	University of Waikato	125
Baer, Kenzie	University of Otago	128
Bailey, Joseph	Victoria University of Wellington	105
Barnett, Josh	University of Waikato	90
Beard, Catherine	Manufacturing NZ	28
Blue, Simon	University of Canterbury	123
Bubendorfer, Andrea	Callaghan Innovation	75
Bunnett, Charlotte	Peke Waihangā – Artificial Limb Service	91
Calloch, Pauline	Callaghan Innovation	35
Chan, Simon	The University of Auckland	53
Chand, Praneel	Waikato Institute of Technology	138
Chen, Qun	The University of Auckland	129
Chen, Zhan	Auckland University of Technology	57
Choudhury, Madhurjya Dev	The University of Auckland	132
Chuter, David	Innovative Manufacturing CRC	29
Claridge, David	ATEED	39
Cleland, Don J.	Massey University	34
Collingwood, Jason	Massey University	117
Coutts, Euan	University of Canterbury	103
Emerson, Nicholas	University of Canterbury	85
Ewart, Paul	Waikato Institute of Technology	80
Fee, Conan	University of Canterbury	98
Fehrer, Julia A.	The University of Auckland	36
Ferreira, Arno	The University of Auckland	99
Flores, Emmanuel	The University of Auckland	139
Fraser, Simon	Victoria University of Wellington	50
Fry, Mike	TIDA	51
Gade, Rohit	Auckland University of Technology	140
Garcia, Lorenzo	Auckland University of Technology	76

PRESENTING AUTHOR	ORGANISATION	PAGE
Gibson, Stephen	Fisher & Paykel Appliances	102
Gillen, Andrew	NETZSCH Australia Pty Ltd	70
Gomes, Lizanne	The University of Auckland	106
Gooch, Shayne	University of Canterbury	112
Grant, Lizzy	The University of Auckland	41
Gravatt, Paul	Motion Design Ltd	46
Hamzeh, Reza	The University of Auckland	136
Hares, Joshua	The University of Auckland	122
Horrell, Mike	Massey University	68
Imrie, Patrick	The University of Auckland	73
Ishii, Melissa	University of Canterbury	126
Jangali, Rahul	University of Waikato	81
Jaywant, Swapna A.	Massey University	93, 124
Johnston, Jim	Victoria University of Wellington	58
Kankariya, Nimesh	University of Otago	78
Kawiti, Derek	Victoria University Wellington/CILOARC Architecture Ltd.	45
Khanna, Jai	Waikato Institute of Technology	113
King, Nikk	NZ Controls	48
Korber, Stefan	The University of Auckland	109
Lal, Kartikay	Massey University	115
Le Guen, Marie-Joo	Scion	67
Leveueur, Jérôme	GNS Science	83
Lewis, Geoff	New Zealand Productivity Commission	63
Lu, Yuqian	The University of Auckland	43
Maletira Karumbaiah, Kariappa	The University of Auckland	86
Malvar, Dylan Luther	Auckland University of Technology	134
Marett, Kevin	LEAP Australia	44
Mark, Brittany	Victoria University of Wellington	55
McDermott, Oliver	Blender Design Ltd	66
McDonald-Wharry, John	University of Waikato	74
McGregor, Angus	University of Canterbury	89
McGuinness, Benjamin	University of Waikato	69
Millen, Caleb	Beckhoff Automation NZ	48

PRESENTING AUTHOR	ORGANISATION	PAGE
Miller, Tim	Victoria University of Wellington	72
Morgan, Hamish	Victoria University of Wellington	52
Murton, Ben	University of Canterbury	100
Naismith, Courtney	Victoria University of Wellington	65
Najaf Zadeh, Hossein	University of Canterbury	94
Nebel, Barbara	thinkstep-anz	64
Notoprodjo, Benedictus	Massey University	120
Olsen, Tava	The University of Auckland	40
O'Riley, Brett	Employers & Manufacturers Association	30
Packer, Adrian	IMS-Projects	108
Patterson, Alistair	Blender Design Ltd	60
Percasky, Rebecca	The Better Packaging Co.	31
Pereira, Tanisha	Massey University	118
Pickering, Nick	University of Waikato	37
Rehmani, Muhammad Asif Ali	Massey University	92
Riley, John	Fisher & Paykel Appliances	61
Ritchie, Annabelle	University of Canterbury	137
Salter, Jessica	Victoria University of Wellington	116
Sanjee, Ardeshir	Auckland University of Technology	82
Schutte, Juan	The University of Auckland	56
Sharplin, Nigel	InFact Limited	84
Shum, Josephine	University of Otago	130
Singamneni, Sarat	Auckland University of Technology	54
Singhal, Ishaan	The University of Auckland	95
Slocum, Alexander	Massachusetts Institute of Technology	96
Smith, Jo	New Zealand Productivity Commission	63
Song, Daniel	The University of Auckland	119
Stilwell, George	University of Canterbury	79
Stringer, Jonathan	The University of Auckland	101
Symons, Digby	University of Canterbury	104
Taore, Aryaman	Beckhoff Automation	42
Tatiparthi, Sundra R. Reddy	The University of Auckland	49

PRESENTING AUTHOR	ORGANISATION	PAGE
Thomsen, Ben	Blender Design Ltd	107
Tighe, Rachael C.	University of Waikato	47
Trompeter, Bill	GNS Science	59
Wells, Christy	Victoria University of Wellington	77
Wilson, Sophie	University of Otago	87
Woodfield, Paul	Auckland University of Technology	38
Wrigglesworth, Emma	Victoria University of Wellington	62
Xu, Shuo	Auckland University of Technology	131
Yan, Jitao	The University of Auckland	135
Zhu, Xexuan	The University of Auckland	133

The MaDE2020 Conference Committee thanks our partners, sponsors and supporters for acknowledging the significance of this event in our national manufacturing, design and entrepreneurial landscape; and especially for standing by with support following the requirement to postpone our event due to COVID-19.

Most importantly, thank you to all delegates for participating in MaDE2020. Following our MaDE2020 Closing Proceedings in Great Room 4 at 3.15pm on Tuesday 8 December, please join us for post-event nibbles and networking at 4.00pm.

Also, your post-event feedback is important to us.

Please complete the DELEGATE FEEDBACK form in your Conference Bag and deposit it in the labelled receptacle.

Alternatively, online feedback forms will be sent to all registered delegates immediately following MaDE2020.

There is a Lucky Draw Prize of \$500.

To be eligible to win you should include your contact details and your feedback must be:

- Submitted by the stated deadline
- Complete and of an acceptable quality



ENGINEERING



MaDE
Manufacturing, Design, Entrepreneurship
New Zealand