



---

# INTERNATIONAL RESEARCH SYMPOSIUM 2021

---

University of Vocational Technology

*"Fostering  
Opportunities  
for  
Technopreneurship  
in the  
New Normal"*

## PROCEEDINGS



# **Fostering Opportunities for Technopreneurship in the New Normal**

**INTERNATIONAL RESEARCH SYMPOSIUM 2021**

UNIVERSITY OF VOCATIONAL TECHNOLOGY

In partnership with  
COLOMBO PLAN STAFF COLLEGE

# **FULL PAPERS**

## **INTERNATIONAL RESEARCH SYMPOSIUM 2021**

### **DISCLAIMER**

Edited by ISSN 2602-8778: © University of Vocational Technology.

The papers published in these proceedings reflect the opinion of the respective authors. Information contained in these proceedings has been obtained by the editors from sources believed to be reliable. Authors of specific papers are responsible for the accuracy of the text and technical data. Neither the publisher nor the editors guarantee the accuracy or completeness of any information published herein, and neither the publisher nor the editors shall be responsible for any errors, omissions, or damages arising out of use of this information. Trademarks are used with no warranty of free usability.

All rights reserved. No part of this publication, including the cover design, may be reproduced, stored or transmitted in any form or by any means, whether electrical, chemical, mechanical, optical, recording or photocopying, without prior permission of the publisher.

## LIST OF REVIEWERS

Emeritus Prof. Andrew Ross	Liverpool John Moores University, United Kingdom
Emeritus Prof. Chitra Weddikkara	University of Moratuwa, Sri Lanka
Chair Prof. K.K.D.S. Ranaweera	University of Sri Jayewardenepura, Sri Lanka
Prof. Chandana Jayalath	University of Vocational Technology, Sri Lanka
Prof. Dayadanda Ambalangodage	University of Sri Jayewardenepure, Sri Lanka
Prof. Dharma Keerthi Sri Ranjan	Sri Palee Campus, University of Colombo, Sri Lanka
Prof. J. P. R. C. Ranasinghe	Uwa Wellassa Univeristy of Sri Lanka
Prof. M.A.J. Wansapala	University of Sri Jayawardanapura, Sri Lanka
Prof. Manjula Vithanapathirana	University of Colombo, Sri Lanka
Prof. N. M. M. G. S. B. Navarathne	University of Sri Jayewardenepure, Sri Lanka
Prof. Prachand Man Pradhan	University of Katmandu, Nepal
Prof. Shironica P. Karunanayake	The Open University of Sri Lanka
Prof. Udayanganee Kulathunga	University of Moratuwa, Sri Lanka
Prof. Yasangika Sandanayake	University of Moratuwa, Sri Lanka
Associate Prof. Nicola Naismith	Auckland University of Technology, New Zealand
Dr. A.S. K. Warahena	University of Vocational Technology, Sri Lanka
Dr. Anuradha Waidyasekera	University of Moratuwa, Sri Lanka
Dr. C.L. Amarasekara	National Institute of Education, Sri Lanka
Dr. Chaiyaporn Silawatchananai	King Mongkut's University of Technology North Bangkok, Thailand
Dr. Chamindi Malalgoda	University of Huddersfield, United Kingdom
Dr. D.D.D. Suraweera	University of Vocational Technology, Sri Lanka
Dr. Dominic Doe Ahiaga-Dagbui	Deakin University, Australia
Dr. Eng. Gayan Aravinda Abeygunawardane	University of Moratuwa, Sri Lanka
Dr. Eng. Petrus Sutiyasadi	Sanata Dharma University, Indonesia
Dr. Ganesh Devkar	CEPT University, India
Dr. Ganga Samarasekara	University of Sri Jayewardenepura, Sri Lanka

Dr. H. P. I. J. Kaldera	Gampaha Wickramarachchi University of Indigenous Medicine
Dr. J. A. E. C. Jayawardena	University of Vocational Technology, Sri Lanka
Dr. J. K. C. Dissanayake	University of Vocational Technology, Sri Lanka
Dr. J.R. Gamage	University of Moratuwa, Sri Lanka
Dr. Janaka Jayalath	Tertiary and Vocational Education Commission, Sri Lanka
Dr. Jayalal Wettasinghe	University of Vocational Technology, Sri Lanka
Dr. K.D.R.L.J. Perera	The Open University of Sri Lanka
Dr. Kalpani Dissanayaka	The Pennsylvania State University, USA
Dr. Kapila Kottegoda	General Sir John Kotelawala Defence University, Sri Lanka
Dr. Kaushalya Wijayasekara	Uwa Wellassa University of Sri Lanka
Dr. L.W. S. Kularatne	University of Vocational Technology, Sri Lanka
Dr. M.P.K.C. Nandapala	University of Vocational Technology, Sri Lanka
Dr. Madhura Jayasinghe	University of Sri Jayewardanepure, Sri Lanka
Dr. Malini Munasinghe	The Open University of Sri Lanka
Dr. Menaha Thayaparan	University of Moratuwa, Sri Lanka
Dr. Pournima Sridarran	University of Moratuwa, Sri Lanka
Dr. Prasanna Illankoon	University of Peradeniya, Sri Lanka
Dr. R. Koggalage	University of Vocational Technology, Sri Lanka
Dr. R. M. P. S. Bandara	General Sir John Kotelawala Defence University, Sri Lanka
Dr. R.S. Palliyaguru	University of Vocational Technology, Sri Lanka
Dr. Ravimal Bandara	University of Sri Jayawardanepura, Sri Lanka
Dr. S. H. K. Deepthika	Gampaha Wickramarachchi University of Indigenous Medicine, Sri Lanka
Dr. S. K. Wijayasekara	General Sir John Kotelawala Defence University, Sri Lanka
Dr. Sashinie M. Thenabadu	University of Colombo, Sri Lanka
Dr. Senesh Dissanaikie Bandara	University of Sri Jayawardanepura, Sri Lanka
Dr. Sondarangallage D. A. Sanjeewa	University of Vocational Technology, Sri Lanka

Dr. Sujeewa Ariyawansa	National Aquatic Resources Research and Development Agency, Sri Lanka
Dr. T. M. K. K. Jinasena	University of Sri Jayawardanepura, Sri Lanka
Dr. Thanuja Ramachandra	University of Moratuwa, Sri Lanka
Dr. Tharushua Ranadewa	University of Moratuwa, Sri Lanka
Dr. Uditha Gayashan Gunasekara	University of Kelaniya, Sri Lanka
Dr. Vipula Wanigasekara	Edith Cowan University, Australia
Dr. Waruni Tennakoon	Buddhist and Pali University, Sri Lanka
Dr. Wasantha Premarathne	General Sir John Kotelawala Defence University, Sri Lanka

**SYMPOSIUM COMMITTEE**

Prof. Chandana Jayalath (Symposium Chair)  
Ms. J. A. M. Buddhima Karunaratna (Co -Secretary)  
Mr. Indika P. Kaluarachchige (Co - Secretary)  
Dr. Ravindra Koggalage  
Mr. S. A. Liyanage  
Mr. H. P. A. I. Pathirana  
Dr. D. D. D. Suraweera  
Dr. L. W. S. Kularathne  
Mr. Dilantha Rathnayake  
Ms. W.P.G.C Pramila  
Ms. Shankani Gunarathna  
Ms. Muthuhari Priyanwada  
Mr. K. Shanmuganathan  
Mr. Dhanusha Premaratne  
Mr. Chandika Karunasekara

**EDITORIAL COMMITTEE**

Prof. Chandana Jayalath  
Ms. J. A. M. Buddhima Karunaratna  
Ms. Indrachapa Gunasekara  
Ms. A. A. Gunawardana  
Ms. H.M.J. Pradeepamali  
Ms. K. T. P. C. Somarathna  
Mr. Nalin Galkanda Arachchi  
Mr. H. A. Gayan Madushanka  
Ms. Dilini Ranasuriya  
Mr. S. Thusyanthan

## MESSAGE OF THE VICE CHANCELLOR

I warmly extend my best wishes for the International Research Symposium 2021 of the University of Vocational Technology. Research is the linkage among universities, industries, research institutes and the society. Research is creative and systematic work undertaken to increase the existing body of knowledge and a way out to find solutions to burning problems. According to the American sociologist Earl Robert Babbie, research is a systematic inquiry to describe, explain, predict, and control the observed phenomenon. In a way, research fosters collaboration among all the stakeholders of the university, namely students, academia and industry. It also has a clear potential to make a significant contribution to the quality of higher education in the country. Therefore, I strongly believe this symposium will help establish a good culture within the university where a platform is provided to present, publish and disseminate tangible research outcomes to a wider audience.

Most of the researches conducted are vocational technology oriented that address most of the issues directly related to the development of the country. It is evident that the quality of the research and symposium proceedings have reached a commendable level showing the commitment of the academic staff to develop the research culture in the University.

In conclusion, I wish to highlight that the University will move towards achieving excellence in all disciplines.

Senior Professor Ranjith Premalal De Silva

Vice Chancellor

University of Vocational Technology



## **MESSAGE OF THE DIRECTOR-GENERAL, COLOMBO PLAN STAFF COLLEGE**

As the former Vice-Chancellor of the University of Vocational Technology (UoVT), and the current Director-General of the Colombo Plan Staff College (CPSC), I take great pride in issuing this message on behalf of our organization as a partner of the “International Research Symposium 2021” currently being held at the University of Vocational Technology.

The University of Vocational Technology (UoVT) is the pioneer TVET University in Sri Lanka that offers degrees, provides teacher training, and conducts research and development activities in TVET. Meanwhile, Colombo Plan Staff College (CPSC) is a regional intergovernmental organization mandated to enhance vocational education and training in the member countries in Asia and the Pacific. Both institutions are committed to further developing the TVET sector of Sri Lanka and taking this collaboration to a larger scale.

Thus it is indeed a privilege for CPSC to collaborate with UOVT in this esteemed event that will bring TVET researchers, academics, and students to foster new opportunities for technopreneurship. In mind is the need for our society to adapt to the new normal and adhere to present health guidelines while focusing on gaining new knowledge and experiences.

Experts worldwide have predicted that the post-pandemic “New Normal” will be far more tech-driven and information-intensive than ever. Thus, there is a pressing need for TVET to face the reality of the “Fourth Industrial Revolution”, a profound transformation of manufacturing and service industries in a connected environment composed largely of big data, people, processes, services, and systems. This revolution is distinctly unique as it foresees the bridging of physical and industrial assets and digital technologies in so-called cyber-physical systems.

In the current context of Sri Lanka, this symposium is timely and relevant. It will give ample opportunities to the participants in enhancing their knowledge. These are needed to adapt to TVET that encourages research on “Technopreneurship”- a convergence of technology and entrepreneurship that often results in much improved outcomes.

I impart my good wishes to the participants and organizers of this symposium and I urge all stakeholders to consider this event as an important step towards the development of TVET in Sri Lanka and the region.

Prof. G.L.D. Wickramasinghe

Director General - Colombo Plan Staff College

President – Asia Pacific Accreditation and Certification Commission

## **MESSAGE OF THE SYMPOSIUM CHAIR**

This year, the number of submissions has continued to grow to 122, reflecting the continued growth in research interests. The 11 plenary sessions for finally selected 79 papers are perhaps a definitive symbol of high quality research outcome. All the papers have been subject to double blind review process and similarity check using a dedicated software. A pool of 166 authors and 60 reviewers contributed to this symposium. As the symposium has continued to grow, we have expanded the team responsible for its high-quality production and dissemination of tangible research outcomes in cross frontiers. We could give scholarly attire within an expanded structure and set of job descriptions as the symposium is clearly evolving into a full-fledged international conference. While navigating the challenges posed by Covid 19, we handed over managerial tasks to a professional event management company. Our sincere thanks go to all of them. Authors, reviewers, session chairs and best award panelists owe this appreciation.

I strongly believe this symposium will help establish a research culture within the university where a digital platform is now provided to present and publish research outcomes to a wider audience.

Professor Chandana Jayalath

Symposium Chair

UoVT International Symposium 2021

## MESSAGE OF THE KEYNOTE SPEAKER

Associate Professor James O. B. Rotimi, Massey University

### Fostering Technopreneurship: The Role of Academia

I would like to welcome you all to the 2021 International Research Symposium hosted by the University of Vocational Technology, Sri Lanka. I consider it an honour and a privilege to participate at this international research symposium on: fostering opportunities for technopreneurship in the new normal. I want to particularly thank Prof. Chandana Jayalath for extending this invitation to deliver this keynote. Having spoken with him about the international conference's vision, mission, and objectives, I have become more convinced that I could add my little worth to this very topical and contemporary discussion point.

#### Nature of Work (the New Normal)

Responding to the new normal, which currently is dictated by the Covid pandemic, is very apt in this year's symposium theme. The definition of work as we used to know it has been radically transformed. The requirements for one's physical presence in work environments is reduced and much of the work occurs in the cloud, as it were. Before Covid, workers' personal expectations had changed according to a UK report/study by Deloitte in 2016. Deloitte had indicated that four things in combination influence workforce expectations, these are: the *workforce demography*. The current workforce demography displays two age-related extremes, on one hand, are millennials, who are much more mobile, and hardly spend more than an average of 16 months at one employment. On the other hand, are the baby boomers (overs 60s), who are still working out of financial necessity. The second influencer of work is the rapid changes in digital technology (such as the internet of things, 3D printing, VR and AR, machine learning etc.), in combination, these are shaping the way work is done. Thirdly, the rate of change in business operational models and innovation that requires businesses and, more importantly, their management to become more agile, quick to change, and a lot more flexible in their approach to doing business. Thus we find a culture of collaboration, information exchange and pursuing a differentiation strategy appearing more in business sectors, compared to previous adversarial relationships amongst business competitors. Fourthly, the Deloitte study talks about the rise of a new social contract between employers and employees where workers now demand an enriching experience, demanding that employers contribute significantly to their personal development; in manners that allow them to grow/rise quickly through the ranks etc. There is also an increase in flexible working arrangements (part-time, contract works etc.) that could enhance workers aspirations for a work-life balance.

I dare add, that some of their submissions may explain the rise of the new set of entrepreneurial spirits that desire their independence, supported by digital technologies and more recently Industry 4.0. It is said, that over 30% of the global population is connected somehow, particularly through social media, where they can interact, learn and share information. The fourth industrial revolution has had a major impact on businesses. For instance, production environments require less human physical involvement to much more remote interactions between supply chains. Li et al. (2020) in their article titled: *Intelligent manufacturing systems in Covid-19 pandemic and beyond: Framework and impact assessment*; provide some descriptions of the possibilities offered by intelligent manufacturing systems that could help create safer working environments through automation. Li et al. were quite optimistic that the modern day production outfits could leverage on existing technologies wherein a combination of the cyber world (computers, artificial intelligence and networks), and the physical world (mechanical devices, equipment sensors etc.) within a closed system can work with very limited needs for human workers. In a nutshell, Li et al. consider that automated production assets (such as production robots, autonomous vehicles, and other intelligent control systems) can be interconnected with ICT that is based within a cloud server. Work activities can be scheduled through this complex system where sensors connected to the production assets determine their operational status and can vary production as may be required. Li et al. conclude that the critical applications required are *adaptive planning, big data analysis* and *sustainable production*. I encourage us to read more about these possibilities and what is

required to make this work further. What is highlighted from these studies is that current circumstances require a radical change in mindsets, changes in approaches at the demand and supply side of every venture in this day and age.

### **The Entrepreneur and Technopreneur**

It is necessary to rationalise that the modern-day entrepreneur needs to be more proactive. They will need to up the ante, see opportunities where others see challenges and act on them quickly. By nature, Entrepreneurs are individuals who pursue opportunities without regard to the resources that they currently control (Stevenson, 1983). In other words, Entrepreneurs are those who refuse to be limited or constrained by their circumstances, they pursue their dreams so long as there is profit to be made.

Normative literature has summed up the qualities or psychological characteristics of the entrepreneur to be *creativity*, *daring* and *aggressiveness*. Thus, Entrepreneurs are creative minded, they are imaginative, inventive, have the ability to think outside of the box. They tend to see further than others. Entrepreneurs are daring, they are brave, courageous, adventurous, bold and fearless, and most importantly not risk averse. They go head on, so long as they are convinced of a higher than average return on their efforts, they proceed. Finally, the Entrepreneur is naturally aggressive, they are success-driven individuals who confront ventures with determination. They do not take no for an answer, they will seek solutions, any solution to get to their goals. Hence an entrepreneur is not your everyday businessperson. Where one threads an old path the other creates new pathways. They are innovative, take massive risks and have tremendous endurance for uncertainties.

The Technopreneur is no different with these characteristics. However, they have an added-on quality of being able to create solutions using technologies. This blending between entrepreneurship and technology aligns with the new normal. Radical, innovative, and with a ravenous appetite for risks.

The theme for this international conference is therefore appropriate and fitting with the current realities, post-Covid. In the promotional for the conference, there were allusions to the challenges of creating technopreneurs for Sri Lanka. The aspirations to create individuals who could access foreign technologies, international markets and financial opportunities that could up-scale their ventures and consequently the general Sri Lankan economy.

### **Training Needs for Technopreneurship**

My focus in this speech is on the role of academia in cultivating this new generation of Technopreneurs. How Universities can create characteristics in individuals for creativity, daringness and aggressiveness. I approach these from three fronts: pedagogical approaches, curriculum review, and university-wide support for business incubation.

Under pedagogical approaches, I would like to address the big question, what needs to change in the way we train the new set of graduates, potential Technopreneurs? I believe there are three futuristic training pedagogies that could benefit the future Technopreneur, these are: *Immersive learning*, *gamification* and *blended learning*.

These three methodologies are based on active learning principles where you involve students more in the content being delivered, making the students more responsible to their learning by getting them to apply and transfer knowledge better. In active learning students retain knowledge better when they are more participative in the learning process through discussions, case studies, workshops, scenario-based role plays etc. Such training approaches are useful in opening up students' thinking horizon to many other possibilities and solutions that exist or could exist. Their training must mimic real life situations as much as possible, providing alternative solutions to situations as if the students were going through that situation.

*Immersive learning* relies on simulation or artificial learning to get the trainees to get immersed in the learning in a way that feels like experiencing an actual work situation. The content of an immersive learning methodology grabs their attention, they learn by doing in an atmosphere that could be

considered leisurely (as if playing). Two technologies that facilitate immersive learning are Virtual and Augmented Reality, VR and AR.

Both VR and AR use computer technology to simulate real-life situations. So an artificial environment can be created to make learners completely immersed in the learning process. For instance, in teaching construction technology courses, with VR, one could bring construction sites to students by using HoloLens'. With this device, they can walk through virtual construction sites, interact with construction forms, watch videos explaining construction systems and methods, and click to get more detailed information of 3D images visible through the HoloLens.

*Gamification* on the hand, involves game-playing of work scenarios. The use of games is not entirely new in training, but its use has expanded into learning situations, where games were never considered possible. Gamification opens up the creative minds of trainees to think outside of the box about the alternative solutions to real life problems. With gamification, one can simulate running a business, alter certain variables (e.g. risks and returns) and constraints in the business and check what effect suggested solutions may have on an organisation's bottom line for example. Such game-based exercises could provide teamwork skills for ensuring business performance and enables trainees to apply sound decisions to complex problems. There is already an explosion of a host of game-based educational at different levels of training that departments/universities can invest in.

Both *immersive learning* and *gamification* need to occur within a conducive learning environment, not the traditional learning environment where knowledge flows in one direction (from teacher to students). *Blended delivery* methodology, therefore, demands more self-directed learning. A flipping of the classroom mentality occurs with considerably higher levels of learner's involvement in their own knowledge development. Students engage in course materials before classroom sessions (lectures or tutorials), predominantly discussions, scenario-based activities, games and role plays. Again, the main idea is to create an expansion of knowledge and ideas beyond what has been provided in the University. Cultivating in the Technopreneur, a liking/habit for research and actively seeking knowledge from their training days and into real life.

Following on from pedagogical changes is the *curriculum* review that is necessary for all qualifications identified/selected for the cultivation of Technopreneurs in the University. Those qualifications must take account of the skillsets needed for Technopreneurship, some of which I have alluded to in my opening presentation. Skillsets such as: ability to take risks; creativity and innovativeness; leadership and visionary, subject matter expertise; technology-savvy; open-mindedness; are but a few of the skills that deserve mention. Creating graduate profiles (set of attributes attainable by a Technopreneur) for these qualifications requires a conscious but determined approach to reflect technological, professional and transferable skills into the curriculum. A greater than usual level of business acumen, finance, digital technologies, communication, and interpersonal relationships must be embedded in the curriculum. Furthermore, a curious (inquisitive) mindset needs to be developed through a whole range of research activities that the future Technopreneur will be involved in during their study programme in the University. You have rightly identified in the conference flyer the need to partner with agencies of change such as the Ministry of Skills Development, Vocational Education and Research and Innovations. All of the initiatives within the Sri Lankan systems are pivotal to University's curriculum design efforts because they have to align well with the goals of those change agencies.

Finally, I would like to conclude by pushing the case for the creation of business incubator, accelerator, and co-working spaces or schemes within the university systems in Sri Lanka. If they do not already exist, this is a good opportunity to develop strategic linkages and synergistic relationships with hi-tech businesses, whether local or international, new or existing. Partnering with deep tech start-ups or existing companies can elevate research within universities and create the necessary expertise amongst staff and students to think more commercially. In New Zealand, for example, the Callaghan Innovation (New Zealand's Innovation Agency) provides grants (stipends) for PG student fellowships when they partner with hi-tech (R&D type) businesses. A PG student jointly tackles solutions to a business problem, with their supervisor(s) and a partner organisation. Alternatively, Callaghan Innovation provides grants to the hi-tech organisations to foster relationships with universities. Co-working or collaborative spaces (of course this does not have to be a physical spaces) offer opportunities for the

meeting-of-minds to entrepreneurs, technopreneurs, the university community and other interest groups. Their coming together will be to connect, collaborate, innovate, and grow their respective ventures. Whichever form the incubator, accelerator or co-working spaces may take, they will result in a win-win for all participants.

At a much smaller level, Universities could encourage the development of business ideas and concepts by their faculties through contestable grants to students and staff. Furthermore, faculties could be provided support by their universities, through regular training/mentoring programmes and workshops that could cultivate innovation, entrepreneurship and Technopreneurship in their students and staff.

I hope by this, I have provided convincing arguments for the role of academia in fostering Technopreneurship in Sri Lanka. Thank you for your audience.

## References

Li, X., Wang, B., Liu, C. *et al.* Intelligent Manufacturing Systems in COVID-19 Pandemic and Beyond: Framework and Impact Assessment. *Chin. J. Mech. Eng.* **33**, 58 (2020). <https://doi.org/10.1186/s10033-020-00476-w>

Stevenson, H. H. (1983). A Perspective on Entrepreneurship. Harvard Business School Background Note 384-131, October 1983.

**International Research Symposium 2021**

University of Vocational Technology

**PROCEEDINGS**

## Table of Contents

### Advanced Mechatronics Applications for Humanity

Design and Analysis of Electricity Energy Generation at a Road Speed Breaker	2
<i>Ravindra Koggalage, S.R.M.P. Seneviratne, K. Pirathusha, D. Dineth Jayathunga</i>	
Design and Implementation of IoT Based Real-Time Toxic Gas Detector	9
<i>R.A.K.P. Akalanka, P.W.L.Y.R. Bandara, K.G.M. Jayasanka, Sondarangallage D.A. Sanjeewa</i>	
Design and Implementation of Smart Accident Assist Service	17
<i>M.Barathy, D.M.S.L. Dissanayaka, G.V.P.I. Weeraratna, K.A.N.I. Pushpakumara</i>	
Design and Prototyping of Environment Sensing and Seed Sowing Robot for Agricultural Applications	22
<i>W.M.T.M. Wasala, M.KI.Marasinghe, K.H.R.A.Senarathne, S.P.A.R.S.Jayathilake, M.W.P. Maduranga</i>	
Design of Automatic Sanitizer for Door Handles and Push Buttons	28
<i>S.R.M.P. Seneviratne, Ravindra Koggalage, K.A.H. Hasaranga Rasanjana, H. A. J. Srimal</i>	
Enhancing Air Quality and Controlling Indoor Air Pollution by Using Low-Cost Air Purification Strategy	36
<i>H.M.R.G Hearth, Sondangallage D. A. Sanjeewa</i>	
IoT Based Smart Home Control and Monitoring System	44
<i>H.S.N. Kumara, A.J.T. Sandaruwan, D.M.D.S. Bandara, Madhavi Perera</i>	
IoT Based Tile Sorting Machine Using Image Processing	49
<i>Viraj Narampanawa, P.D.M Tharaka, H.M.E.C Herath, Dilshan Ganegoda</i>	
Remote Controlled Solar Powered Grass Cutter	55
<i>Ravindra Koggalage, S.R.M.P. Seneviratne, R M C Lakmal, H W A Eshana , M. Aathawan</i>	

### Emerging Technologies in the Manufacturing Sector

An Economic Assessment of Rooftop Solar Photovoltaic in Northern Province of Sri Lanka	63
<i>Thushana Uruthiran, Sampath Ediriweera</i>	
Design and Development of Vertical Axis Wind Turbine for Power Generation in Expressways	70
<i>Dilan Manathunga, Tharindu Karurarathna, Ishani Kanchana, Jayalal Wettasinghe</i>	
Design and Fabrication of Multi-Functional Pipe Fitting Tool	76
<i>K. G. Alahapperuma, T. R. Paranamanaana, K. T. D. Kalansooriya, I. G. P. Darshana Gunarathna</i>	
Factory Observer Pneumatic Hybrid Vehicle	82
<i>T.D.C.S Abeywickrama, B.M.I.M.B Bulathge, A.A Thilina Lakmal, U.M.R.B Ulpunge, Dilshan Ganegoda</i>	
Gasified Oil Burner Prototype Development: Potential for Local Industrial, Commercial and Household Applications	90
<i>S. Sachintha, G.D.T.N Kumarasiri, B.A.V.M Bamunuarachchi, Aruna Warahena</i>	
Multiple Linear Regression Method for Predicting Mechanical Properties of Low Carbon Steel during In-Process Inspections	95
<i>K. G. Alahapperuma, N. Nandhakumar</i>	

### Harmonious Cohabitation of ICT in Vocational Technologies



Awareness of Internet Browsing Security among Undergraduates in Rajarata University of Sri Lanka	102
<i>D.N. Jayathunga, D.M.T. Madushanka</i>	
Challenges in the Use of Big Data Analytics	110
<i>M.I.M. Rifkhan, ZAM. Safzath, HPAI Pathirana</i>	
Concurrent API Communication and the Utilization of Circuit Breaker Design Pattern	117
<i>Diyanada J. Gunawardena</i>	
Online Management System for Large Scale Pharmacies	125
<i>M. Pavucsan, M.R.R. Banu, M. Gowthami, L. Pradeep Kalansooriya</i>	
Use of GIS Technology as a Tool for Locating Public Libraries	130
<i>S.C.D. Siyambalapitiya, R. C. Gamage</i>	
<b>Harnessing the Opportunities in Hospitality Industry through Advanced Technologies</b>	
Effectiveness of Digital Media Platforms in Promoting and Marketing Sri Lanka Tourism	139
<i>R.P.S.K.Rathnaweera, B.V.D.R.Dharmarathna, B.M.T.D.Jayasekara</i>	
Impact of Technological Amenities on the Operational Performance of Hotels: A Case Study Based on Galle District	144
<i>D.M.P. Madhushani, C.P. Danthanarayana, S.F Fazana</i>	
Motive for Community Involvement in Tourism Entrepreneurship: with Special Reference to Southern Province in Sri Lanka	152
<i>K.P.I.S. Jayasekara, G.T.W. Sriyani</i>	
Role of Perceived Organizational Support in Determining Turnover Intention: A SEM on Employee Awareness of Smart Hotels in Sri Lanka	160
<i>C.P. Danthanarayana, M.A.D.J. Jayathilake, R.M.P.D.K. Rajapaksha</i>	
Tourism Promotion in Sri Lanka Using Landscape and Scenery Photography	170
<i>U.A. Dhanusha Premarathna, M.M.K.S. Dissanayake</i>	
<b>Industrial Management through Innovative Technologies</b>	
An Analysis of the Relationship between High Tech Exports and Unemployment	179
<i>S. Niroshanth</i>	
A Review on Outsourcing Strategy and Firm's Superior Performance	185
<i>K. A. I. M. Amarasekara</i>	
Assessment of Municipal Solid Waste Management System in Colombo Municipal Council	192
<i>D.C.M. Abeyakoon* and T. Denagama</i>	
Crowdfunding Large Scale Solar Power Generation Projects	198
<i>J. K. Kanthi</i>	
Factors Influencing Brand Preference of the Cake Industry	205
<i>Shalika N. Wanniarachchi, U. G. Rajapaksha</i>	
Factors Influencing Cosmetic Buying Behavior of Males: with Special Reference to Galle Area	211
<i>H. G Dayal Shamin Samarasinghe, J.W.P Dilsha Chathurangi</i>	
Perceptions of Household Level Micro Scale Waste Disposal Methodologies among Apartment Dwellers in Sri Lanka	219

*S.R.M.P. Seneviratne, K.G.N.P Rajapaksha*

### **Innovative Construction Technologies**

Applicability of Modular Construction Innovation in Residential Buildings in Sri Lanka	227
<i>D.Dharmendra, S. Thusyanthan</i>	
Critical Barriers in Implementing Sustainable Construction Methods among Small - Medium Contractors in Sri Lanka	234
<i>K. D. M. Gimhani, P.L. Perera</i>	
Mechanical Behaviour of Concrete with Recycled Plastics	242
<i>D.U. Dayananda, Kasun Nandapala</i>	
Potential Species of Plants and Growing Substrates for Roof Greening in Tropical Regions	248
<i>B.G.R.R Bandara, M.P Charithangi, M.D.S.W Goonathilake, H.M.T.P Herath</i>	
Rain Water Harvesting System to Supplement Non-Potable Water Requirements - Designing Domestic Dwelling in Colombo Suburbs	256
<i>K.D.C Nimalka, B.B.L.R Rathmasena, D.D.D. Suraweera</i>	

### **Managing Construction Projects for Better Value for Money**

Construction Procurement Selection Factors: A Comparative Study on Traditional vs Design and Build Systems	265
<i>M. P. C. Kuruppu, V. Srivishagan, R. Thalpage</i>	
Employee Satisfaction with the Intrinsic and Extrinsic Motivation Factors in Sri Lankan Construction Industry	273
<i>I.H.P.R. Indikatiya, N.S. Karunasinghe, M.N. Dilhani, T.D. Weerasekera</i>	
Energy Benchmark Analysis of Supermarkets	281
<i>Chamila Sumathiratna, D.D. D. Suraweera, Anusha Wijewardane</i>	
Examining the Exclusive Nature of Construction Claims during the Covid-19 Outbreak	288
<i>Chandana Jayalath, Asitha Kanchana</i>	
Concurrent Delays in Sri Lankan Construction Industry: Challenges and Approaches	294
<i>W. A. C. R. Premakeerthi, R. Thalpage, V. Srivishagan</i>	
Site-Level Patronage Given to Covid-19 Health Protocols; A Sri Lankan Experience	300
<i>Thilini Andawala, Chandana Jayalath</i>	

### **Optimizing Value of Food Technologies**

Health Effects and Physicochemical Properties of Traditional Rice Varieties vs Improved Rice Varieties	308
<i>Yasintha Wickramasinghe, M. M. J. O. Wijekoon</i>	
Development and Evaluation of Orange Flavoured Fermented Buttermilk	314
<i>S. D. D. N. Indrajith, C. J. Abeywickrama</i>	
Development of a Colour-Based Quality Analysis Tool for Sri Lankan Bee Honey	320
<i>O.W.S. Madusanka, P.P.A.J. Rathnayake, G.M. Somaratne, D.H. Belligala, G.G.R. Wimukthi</i>	
Development of Ash-Plantain Based Sauce with Incorporation of Oyster Mushrooms Powder	328
<i>S.L.T. Kumarasingha, U.A.S.K. Edirisinghe, M.A.J. Wansapala, G.W.A.S. Lakmini</i>	

Development of Jackfruit Flesh Flour Incorporated Healthy Composite Flour Mixture with Selected Grains and Pulses	335
<i>M.L.P. Thathsarani, M. A. J. Wansapala, U.A.S.K. Edirisinghe, G.W.A.S. Lakmini</i>	
Marine Sponges as Anti-Inflammatory Drug Leads: An Overview	342
<i>N.P. Ranatunga</i>	
Non-Metalize Composite Materials on the Shelf Life of Hard Dough Plain Biscuits	347
<i>Praveen Kanakarathna, U.A.S.K. Edirisinghe</i>	
Organoleptic Properties of Curd Prepared by Alternative Starter Cultures used to Replace Existing Starter Culture	356
<i>J.H.I.G. De Silva, A.M.N.L. Abesinghe</i>	
Textural and Microstructural Properties of Semi - Hard Cheese, Processed Cheese and Milk	361
<i>Manoj Imbulegama</i>	
The Potential Contribution of Soy Isoflavones in the Health of Menopausal Women, Revealing the Avenues for Soy Food Manufacturing Industry	366
<i>J.M.C.M. Jayasekara, S.M.C.S. Samarakoon</i>	
Usage of Domestic Refrigerators for Safe Food Storage among Sri Lankan Families	372
<i>J.M.C.M. Jayasekara</i>	
<b>Teaching and Learning Environments</b>	
Collaborative E-Learning Applications in the Sri Lankan Vocational Education	381
<i>K.P.I.S. Jayasekara, C.P. Danthanarayana, K.A.I.M Amarasekara, A.P.R.P. Pathirana</i>	
Effectiveness of On-the Job-Training in Welding Trade	390
<i>D.H.U.Eranda, P.M.K.Kumarasinghe, K.K.A.S.S.R.Britto</i>	
Effects of Students' Attitude towards Online Learning in Covid-19 Pandemic with Reference to Management Undergraduates	398
<i>Indrachapa Gunasekara, Jayathree Herath, Uruthiran Sivachelvy</i>	
Factors Affecting Students' Performance in Mathematics: A Case Study based on Secondary Schools in Mawanella, Sri Lanka	406
<i>M.N Nafra Farwin, Jayalal Wettasinghe</i>	
Factors Influencing the Classroom Climate on Academic Performance	411
<i>Pragash Mithulaa, PadmaShanthi Y. Gamage</i>	
Factors Influencing the Usage of Physical Resources on Academic Performance	417
<i>G.G.W.E. Kumaradasa, Padma Shanthi Y. Gamage</i>	
Ground Reality of Emergency Remote Teaching during Covid 19 Pandemic: Experiences of Teachers of English in Uva Province, Sri Lanka	424
<i>M.P.S.P Dias, S.B.C. Rangana, J. A. M. Buddhima Karunarathna, A. A. Gunawardana</i>	
'I Hate Online Classes': Challenges and Perceptions of Students on Online Learning	431
<i>Suranmali Prananda</i>	
Impact of Cultural Affinity on Foreign Language Learning	437
<i>J. C. Munasinghe</i>	

Impact of Formative Assessment Mode on Summative Assessment of Upper-Secondary School Students	441
<i>M.M.N. Sarfa , S.A.N. Danushka</i>	
Online Teaching in ELT Class Room – A Survey on Government English Language Teachers of Sri Lanka	447
<i>D.S. Premarathne, L.H.D.L. Ranasuriya</i>	
Technology Teachers’ Professional Satisfaction and Working Environment	453
<i>D. K. Chathumi Nawanjana, Y.S. Manathunge, Prasanna Illankoon</i>	
<b>Techno - Social Sustainability</b>	
A Follow up Study on the Career Progression of the First Batch of Graduates of University of Vocational Technology	461
<i>D.D.D.Suraweera, L.W.S.Kularatne</i>	
Contribution of Technical and Vocational Education in Poverty Reduction: A Case from University of Vocational Technology	467
<i>N.L.B. Oshadie, Dilini Ranasuriya, Jayalal Wettasinghe</i>	
Delineating Elephant Corridors in North-Western Wild Life Region	474
<i>B.A. Asika Sewwandi, Malani Herath</i>	
Job Market Opportunities via Social Networking Sites	482
<i>A.W.K.G. Wijesingha, L.H.D.L, Ranasuriya</i>	
Establishment of an Energy Baseline: A Case Study on Possibility of Transforming University College of Jaffna (UCJ) to Near Net Zero Energy Building	488
<i>Ravindra Koggalage, Somasundaram Thuvaragan, S.R.M.P. Seneviratne</i>	
Issues and Challenges of Women in Sri Lankan Construction Industry	495
<i>Vijayaragunathan Srivishagan, Rasanthi Thalpage</i>	
Online News Consumption Behavior in Sri Lanka	501
<i>H. A. Gayan Madushanka, W.M.S. Sulakshi Rathnayake, Kishan Chaleendra Amarasinghe</i>	
Survival Strategies in the New Normal Adopted by Quantity Surveying Firms in the Gulf Region	508
<i>Chandana Jayalath, Iresha Gamage</i>	
<b>Technological Advances for Nurturing Education</b>	
Challenges in Using Online Learning Platforms by Undergraduates of the University of Vocational Technology during Early Covid-19 Pandemic Period	516
<i>R.M.A.C. Rajakaruna, Padma Shanthi Y. Gamage</i>	
Effectiveness in Online Reading during Covid-19	523
<i>A.W.K.G. Wijesingha, L.H.D.L,Ranasuriya</i>	
Experiences in Online Learning during Covid-19 Pandemic in a College of Technology in Sri Lanka	530
<i>M. Pirashanthan</i>	
Online Course Delivery during Covid -19 Pandemic in Sri Lankan Universities: Students’ Perspectives	537
<i>T. K. Malwatta, L.W.S. Kularatne</i>	

Propensity among the Undergraduates to Use Mobile Phones and its Impact on Academic Activities; A Case Study	542
<i>Ravindra Koggalage, M.A.A.S. Nazik</i>	
<b>Author Index</b>	549

**Note:** *After publication, the corresponding author is the point of contact for queries about the published paper. It is their responsibility to inform all co-authors of any matters arising in relation to the published paper and to ensure such matters are dealt with promptly. The corresponding author is responsible for the accuracy of all content of the intact research paper in the proceedings.*

# **ADVANCED MECHATRONICS APPLICATIONS FOR HUMANITY**

# Design and Analysis of Electricity Energy Generation at a Road Speed Breaker

Ravindra Koggalage<sup>1</sup>, S.R.M.P. Seneviratne<sup>2</sup>, K. Pirathusha<sup>3</sup>, D. Dineth Jayathunga<sup>3</sup>

<sup>1</sup>Department of Electrical and Electronics Technology, University of Vocational Technology, Sri Lanka

<sup>2</sup>Department of Quantity Surveying, University of Vocational Technology, Sri Lanka

<sup>3</sup>Department of Mechanical and Manufacturing Technology, University of Vocational Technology, Sri Lanka

## ABSTRACT

*As finding alternative ways for power generation is one of the immediate needs of Sri Lanka. In this study, electrical power generation appliances from the vehicle Speed Bumping used as a safety device on the road are identified. This would be very useful for temporary road construction sites in remote areas where roads were in dark and accidents can be occurred very often due to limited visibility. Electricity generated can easily light up the dangerous area. In this research, an experimental model is developed to identify a mechanism by using Rack and Pinion arrangement to convert motion at the road bump into rotational motion of a dynamo. A rack & pinion arrangement was used to rotate the dynamo, then the reciprocating mechanism was used to obtain better efficiency. Through a Dynamo the rotational energy is converted into electrical energy shown by the glowing of the LEDs. Output power to be expected to have 3-4 W in the designed prototype, and can be improved further depending on the requirement in the real implementation. The experimental prototype is simulated and the design parameters were shown.*

**Keywords:** Kinetic Energy, Power, Rack & Pinion Arrangement, Speed Bumps, Speed Breaker Power Generator (SBPG).

## 1. INTRODUCTION

There is a need identified in the research community to prone at the application of renewable energy sources to reduce pollution and save fossil fuels. (Rao D, V., Rao K.P., Rao S.C, Rao R.U., 2014). It was considered as the cheapest source for energy is gained by conversion one method of energy towards another source. As Energy conservation can be considered as the cheapest new source of energy, attractive technology is in search of optimal use in available sources. (Das C. K., Hossain S. M., Hossan M. S, 2013).

In this project, it attempts to show how the energy can be commissioned at a road speed breaker, constructed at roads surfaces to break the speed of vehicles. When the vehicle passes over road speed breakers considerable amount of energy is supposed to waste on speed breakers overheating and the form of friction force. By tapping this energy, electricity can be generated at speed breakers accommodated by a power generation unit. Therefore, in the project, the possibility of employing the wasted sort of energy at road speed breaker was explored by utilizing the wasted energy by converting wasted energy to electrical energy through energy conversion processes.

In the South Asian context, there are several attempts made in these aspects developing prototypes to be used for producing green electricity from speed breakers from road bumps, with experimental data at performance analysis in scopes for further improvements. In Bangladesh, there is a proto-type developed in this scenario specially established to generate electricity when a vehicle passes over the proposed mechanism, as the system compresses springs causes linear vertical motion at a rack. Further the rack movement develops a pinion to rotate therefore as the pinion is mounted on a generator input shaft will produce electricity. (Islam R., Faisal A. H. M., Abdul M., Motaleb, 2017).

In this way, prototypes are proposed to support the development of Green energy over wasted sources of such as electricity-generating at speed breakers, as a frequent archetype in the scientific frameworks.



## 2. PROBLEM STATEMENT

The applications of speed breakers and bumps on roads are utilized to reduce the number of accidents on road. Speed Bumpers work to force drivers to slow the speed. Yet, these speed bumps create noise with vehicle damage with great speed, and conversion and wastage of form of energy into other forms.

In Sri Lanka, the source usual use for electricity generation stations are from the hydro-electricity applied power plant or thermal electric power plant, and wind energy at most. The hydro-generated power is based on water and river sources of Sri Lanka, while for thermal type, sources such as coal petroleum are usually used.

Since fossil-based fuel sources are used in Sri Lanka, the overall cost for the energy systems is high. Therefore, non-conventional systems that would generate energy in renewable forms can be identified and highly recognizes in the context of energy consumption and generation. Renewable forms of energy on the other hand would also reduce environmental pollution caused by the consumption of fossil fuels. Efficient, easily applied, and innovative Energy generating systems to generate electricity in green forms are highly anticipated in the energy-generating context. In this project, means such as producing green electricity at road speed bump with mechanical means were identified. This could be considered as an effort in this means as a respectable solution for low-cost green electricity generation, by a wasted source of energy.

## 3. AIM

In this project converting Mechanical energy into Electrical energy and utilizing the energy, dissipation is identified in a convenient way.

The mechanism is to be identified with the Rack and Pinion arrangement transform motion of the bump into the motion of rotational of the dynamo. As the first footstep, the rack & pinion arrangement uses to rotate the dynamo. Later, the reciprocating mechanism to use to capture with better efficiency. Rotational energy through a Dynamo is to convert into electrical power. The electrical energy output will be shown by glowing the LEDs. The output energy is anticipated to have 3-4 Win prototype.

## 4. LITERATURE REVIEW

### 4.1 Wasted Energy Converted to Electrical Energy

Rao A.P., Kumar A.K., Suresh S., identified the importance of renewable sources of energy for nonpolluting energy (Rao A.P., Kumar A.K., Suresh S., 2014). It was understood the need to change aligned with the use of renewable energy means to reduce pollution and save fossil fuels. (Rao D, V., Rao K.P., Rao S.C, Rao R.U., 2014) Energy conservation can be considered as the cheapest new source of energy, as an attractive technology by Das C. K., Hossain S. M., Hossain M., in optimal use in available sources. The cheapest new source of energy by the change of one form of energy into any other source. (Das C. K., Hossain S. M., Hossain M. S, 2013)

### 4.2 Mechanisms of Speed Breakers to Appoint Wasted Energy

The option of determining the residual energy of a road reducer was studied, that is, the residual energy converted into electrical energy by a roller mechanism by means of an energy conversion process.

The electrical energy obtained is determined in the KW range, enough to turn on traffic lights and traffic lights. As the number of vehicles increases, the designed system can be used as an effective mechanism to solve energy crises. (Das C.K., Hossain S.M., Hossain M.S., 2013)

Speed breakers are designed for heavy vehicles which increase input torque and increase power as output. Within many mechanisms to enhance efficiency, Rao A.P., Kumar A.K., Suresh S., identified worked at a developed rack and ratchet (pinion) mechanism to use to develop the power from speed breakers. Generated power to use for the lamps near the speed breakers. (Rao A.P., Kumar A.K., Suresh S. 2014).

The possibility is found of beating the energy increasing since a number of vehicles that are passing and bumping at speed breaker on roads rises while generating power with speed breaker used at power generation unit. The components in the mechanism to fabricate and assembled. In the mechanism of lever linear motion to be transformed into rotary motion by at crankshaft, with theoretical calculations and speed obtained amplified by using set of gears used to run a generator (Rao D, V., Rao K.P., Rao S.C, Rao R.U.,2014)

It was seen by Mishra A., Kale P., and Kamble, how a vehicle uses wasted energy when passing through a speed bump. The energy generated from the road breaker is used as a power generation device, and the stirring vehicle kinetic energy is converted into shaft inclined mechanical energy at a rack-and-pinion mechanism. The generator is then used to convert mechanical energy into electrical energy which is stored in the battery. (Mishra A., Kale P., Kamble A., 2013)

Ullah KM, et al, 2016 defined a mechanism used by using the energy generated from a moving vehicle as a power generation to eliminate impact pressure when the vehicle passes through a road breaker. Here, the moving vehicle kinetic energy through a rack-and-pinion mechanism to converted into mechanical energy. Generators used to turn on street lights are used to convert mechanical energy into electrical energy. (Ullah K.M., Zaman K.M.A.U., Hosen S., Khan R.H., Parvin S., 2016)

(SBPG) Speed Bump Power Generator system generates electrical power applying the actions of traveling vehicles translates vertically is identified by Ramadan M., Khaled M., El-Hage H., (2015). Kinetic energy developed then converted into electrical power with SBPG systems types presented, with rack-and-pinion systems. Around 0.56 kW power produced with different masses carrying vehicles pass through the bumps. (Ramadan M., Khaled M., El-Hage H., 2015)

Maurya J., Gupta P., Shahab T., Srivastava A., emphasized power generated over speed breakers, with kinetic energy wasted on roads and stored in batteries. Generation of power is done using the method of rack-pinion converted to rotary motion by a linear motion, to generate electricity. (Maurya J., Gupta P., Shahab T., Srivastava A., 2016)

Energy generated system by Speed Breaker Power Generator (SBPG) produces electrical power identified by Azama A., Aslamb M.A., Alic S. as a study to generate electricity by SBPG, with a rack and pinions mechanism. (Azama A., Aslamb M.A., Alic S., 2016)

## 5. METHODOLOGY

An experimental prototype Modal is developed to identify a Mechanism to convert the wasted energy at a road bump with kinetic energy wasted on roads towards the rotational motion of a dynamo using a Rack and Pinion arrangement, and stored in batteries. Literature was studied to develop the experimental model, to identify as a rack & pinion arrangement used to rotate the dynamo, responding mechanism used to obtain better efficiency. Rotational energy is converted

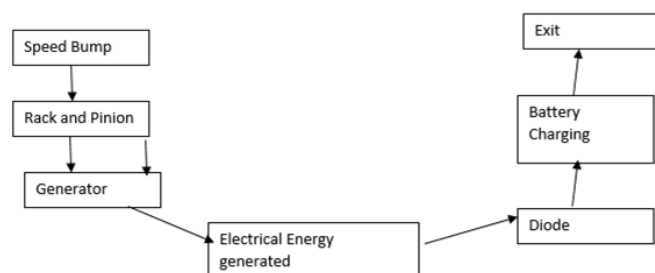

Figure 1: Block Diagram

into electrical energy through a dynamo indicated by the glowing of the LEDs. Output power to be expected to have 3-4 W in the designed prototype.

**5.1 Materials**

Materials applied are: Gear, Compression Springs, Light Emitter Diode/Multi-meter, Dynamo, Sprocket and Chain. Shaft and Bearing, Methods Rack and Pinion

**5.2. Experimental Design Modal**

As the vehicle touches the bumper, linear motion created with the rack moves downwards. The rotational motion created as changing the linear motion of the rack with two pinions connected to the rack. Together the two pinions movements have a directional state. Two gears are connected to the pinion shaft and mechanical power is transmitted to the shared shaft through the gears. The pinion shaft uses a flywheel to provide uniform motion. Submerge the entire gearbox in the lubricant to lessen friction losses. Brushless DC generators produce DC electricity which is stored in batteries.

**6. RESULTS**

**6.1. Assumptions at Design Prototype**

Table 1: Design Rack Table

Class BR basic rack	
ALANTA quality	10
Module	1
Total pitch error	200
Tooth thickness tolerance (µm)	110
Maximum length (mm)	990
kN	2.0
Series	21/23
Heat-treatment of tooth	Soft
Tolerance of teeth 8e 25	20
Page	ZB-28-35

Table 2: Design Gear

Gear	Calculation	Result
<b>Module(m)</b>		10
<b>teeth (No) (t)</b>		20
<b>Angle of Pressure (Q)</b>		20°
<b>Diameter of Pitch circle (PCD)</b>	$m \times t$	200m
<b>diameter of Base circle</b>	$PCD \times \cos\phi$	187.9 mm
<b>No of Addendum(a)</b>	$a = m$	10mm
<b>No of Dedendum(d)</b>	$1.25 \times m$	12.5m
<b>No of Clearance diameter of Tip circle</b>	$d - a$	2.5mm
<b>diameter of Root circle</b>	$PCD - 2d$	175m
<b>No of Circle pitch (p)</b>	$\pi \times m$	31.4m
<b>thickness of Tooth</b>	$p \div 2$	15.7m
<b>Angle of Pitch</b>	$360 \div t$	18 °

Table 1 and Table 2 depict the design parameters of the Rack Table and Gear. Graphical representations of them can be found Figure 2 to Figure 9.

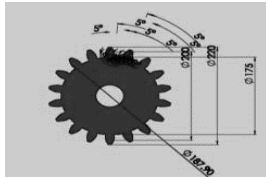

Figure 2: Gear

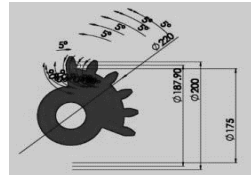
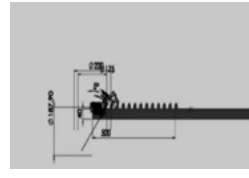

Figure 3: Pinion



Specification of pinion are shown in figure 13 and the Feed Force Assumed is shown in Figure 14.

Rack C45ind. hardened, straight tooth, module 3,  
pinion 16MnCr5, case hardened, 15 teeth, ZB-40  
with  $F_{u\ tab}=11.5kN$  ( $F_{u\ tab}$  –permissible feed force)  
 $F_{u\ zul. / per.}=F_{u\ Tab}/K_A * S_B * f_n * L_{k\ h\ \beta}$ ;  
 $F_{u\ zul/per.} = 11.5kN/1.10*1.2*1.10*1.1$   
 $=7.2kN$

Figure 14: Feed Force Assumed

Vehicle Weight =  $300Kg * 9.81 = 2983.00\ N$   
Therefore,  $P=2.983\ K\approx 3KN$   
Permissible shear stress = 0.5 of sut  
 $\tau=0.5*sut$  (ultimate tensile strength)  
 $\tau=0.5*1050=525\ N/mm^2$

Figure 15: Spring design parameters

### 6.3. Design of Spring

Spring design parameters for 300kg weight are shown in Figure 15, and Stiffness of the spring  $k$  and Wire diameter  $d$  calculation can be found in Figure 16 and Figure 17 respectively.

$K=(4c-1/4c-4) + (0.615/c) \dots \dots \dots$  std formula  
 $K= (4*8-1/4*8-4) + (0.615/8)$   
 $K=1.184$

Figure 16: Calculation of  $k$

$\tau=k*(8pc/\pi d^2)$   
 $525=1.184(8*3000*8/\pi*d^2)$   
 $D=12mm$   
spring Free length =230mm

Figure 17: Calculation of  $d$

Rack specification and design are shown in Figure 18 and Figure 19.

gear Pitch circle diameter = 72mm  
gear Circumference =  $\pi \times$  pitch circle diameter  
 $= \pi \times 72 = 226mm$ ,  
dimension taken for 360°rotations  
rack length for 180° rotations =113 mm

Figure 18: Rack design

Material specified: cast iron  
Module specified: 1.5mm  
Specified Cross-section:752 x 5mm Teeth on  
the rack is adjusted for 113mm

Figure 19: Rack specification

Output power has been calculated as shown in the Figure 20.

Considerations:  
body mass = 300Kg (Approximately)  
speed brake Height = 10 cm  
 $\therefore$  Work done calculation = Force x Distance  
Force = Body Weight = 300 Kg x 9.81 = 2943 N  
body Distance traveled = speed brake Height = 10 cm (0.10 m)  
 $\therefore$  Output power calculation = Work done/Sec  
 $= (2943 \times 0.10)/60$   
 $= 4.905\ Watts$  (For One pushing force)

Figure 20: Output power calculation

As the Stresses are below than the Yield strength of materials, the design has met its safety.

## 7. CONCLUSION

Identifying energy recovery systems that are pollution-free has become a significant goal within the research community. Numerous systems have been proposed that produces electrical power by

utilizing the movements of commuting vehicles on highways and streets while utilizing the jerking pressure wasted during the vehicles passes over bump speed breaker on the roadside.

In this paper, a prototype-experimental modal is proposed to exhibit electric power generation towards green energy development, in order to utilize the wasted energy at bump speed breaker in roadside considering the scope for further improvements. The prototype was designed to exploit the shaking pressure wasted while the vehicles pass over the speed breaker of the roadside and energy was generated using speed breaker as a power generating unit. In this project, energy was designed to be generated by using a speed breaker as a power generating unit, by the kinetic energy of moving vehicles, then converted into mechanical energy by a rack and pinion mechanism. The electrical energy output is shown by glowing LEDs. Output power is 3 to 4 W in this prototype.

Solid work and CAD software used in designing, modeling, and analyzing the parts before manufacturing. In the project, it has been found that Von-misses stresses, deformation, and shear stress for all materials obtained from ANSYS are very close to the theoretical values. As these stresses are below the Yield strength of materials, the design is considered safe. This technology would facilitate the future creation of new railway stations, bus stands, and airports capable of connecting movement for electricity generation in a green manner.

## REFERENCES

- Azam A, Aqeel M., Ali S and Zai Y (2016) Speed Breaker Power Generator. In *4th International Conference on Energy, Environment and Sustainable Development*.
- Das C.K., Hossain S.M. and Hossain, M.S (2013) Introducing speed breaker as a power generation unit for minor needs *International Conference on Informatics, Electronics and Vision (ICIEV) IEEE. DOI: 10.1109/ICIEV.2013.6572532 :1-6*.
- Islam R., Faisal A.H.M. and Motaleb, M.A. (2017) Power Generation from Speed Reducers Using Rack-Pinion Mechanism. *International Conference on Mechanical Engineering and Applied Science, ICMEAS Mechanism Department of Mechanical Engineering*
- Maurya J, Gupta P, Shahab T and Srivastava A, (2016) Generation of Electricity through Speed Breaker Mechanism, *The International Journal of Engineering and Science*, 5(4) :43-48,
- Mishra A, Kale P and Kamble A, (2013) Electricity Generation from Speed Breakers. *The International Journal of Engineering and Science*, 2(11): 25-27
- Speedbumps-vs-speed-hump (2012)
- Ramadan M, Khaled M and El-Hage H (2015) Using Speed Bump for Power Generation – Experimental Study. *Energy Procedia, Science Direct*, 75: 867-872
- Rao AP, Kumar AK and Suresh S (2014) Power Generation from Speed Breaker by Rack and Ratchet Mechanism. *International Journal of Current Engineering and Technology E-ISSN 2277 – 4106, P-ISSN 2347 - 5161*
- Rao DV, Rao KP, Rao SC and Rao RU (2014) Design and Fabrication of Power Generation System using Speed Breaker. *International Journal of Current Engineering and Technology*, 4(4)
- Singh AK, Singh D, Kumar M, Pandit V and Agrawal S (2013) Generation of electricity through speed breaker mechanism. *International Journal of Innovations in Engineering and Technology (IJIET)*, 2(2): 20-24.
- Ullah KM, Zaman KMAU, Hosen S, Khan RH and Parvin S (2016) Electrical power generation through speed breaker. *9th International Conference on Electrical and Computer Engineering (ICECE)*

# Design and Implementation of IoT Based Real-Time Toxic Gas Detector

R.A.K.P. Akalanka, P.W.L.Y.R. Bandara, K.G.M. Jayasanka, Sondarangallage D.A. Sanjeewa\*

Department of Electrical and Electronic Technology, University of Vocational Technology, Sri Lanka

## ABSTRACT

*New ways of life will accompany the advancement of mechanization in everyday life. When new problems arise, new solutions must be found, so people will be asked to design new solutions based on the implementation of sensor-based networks in order to achieve acceptable and improved living conditions. The primary objective of a toxic gas detector is to make efficient use of sensors to measure real-time toxic gas detection technology in combination with a security system that will activate when a toxic leakage is detected. Sensor-based systems are widely used in industry today because, when it comes to safety sensors, this type of real-time toxic gas detector creates a comfortable atmosphere in the workplace and makes employees feel more at ease. A 12v battery is used to power this system. When the toxic level rises and the warning system is activated, this detector sends a message to the responsible person. This detects even the tiniest difference and thoroughly analyzes it to look for anomalies. The results of the analysis are then displayed in real-time by the system.*

**Keywords:** *IoT based toxic gas detector, Leakage Detection, Real-time monitoring, Toxic Gas Detector, Wireless Network*

## 1. INTRODUCTION

Alongside the growth of the economy, the production and industry environments have been more active. So, they have tried new ways to make the production faster. As an effect of this, every process in a plant may emit toxic gases. So, when they make more toxic gases, the industrial environment is more dangerous to the workers. We only utilize H<sub>2</sub>S, CO<sub>2</sub>, NH<sub>3</sub>, and CO since these are the most potent hazardous gases. Typically, H<sub>2</sub>S is found during crude oil and natural gas drilling and production, as well as wastewater treatment, utility facilities, and sewage systems. (Seaman.n.d., no date) Most industries contain CO<sub>2</sub> as a toxic gas because most of the plantations emit CO<sub>2</sub> when the product is made. NH<sub>3</sub> means ammonia, and it is used in nitric acid production, as a fertilizer, and as a cleaning solution. Long-term exposure is caustic and harmful. (Harper and Croft-Baker, 2012) CO means carbon monoxide, and it is a poisonous, colorless, odorless, and tasteless gas. So when we work in a plant area or an industrial area, workers must know and feel safe when they work. Because of that, we designed and implemented this IoT-based toxic gas detection system that will help workers identify and contain a toxic gas leak quickly through the alarm system.

## 2. LITERATURE REVIEW

The people that work in the plant area is called plant workers. They are the ones that make the production line. So, their health is more important. Because industry contributed approximately 27.4 per cent to the Sri Lankan economy when the workers work in a plant area, the plant emits toxic gases, and the workers can get affected. If workers get affected by toxic gases, they might die or won't be working anymore. (Statista.n.d., no date) So, if a worker dies in a toxic gas affection, the other workers get scared or won't come to work, so this can get the economy down by like 7% because various societies connect all the workers. In this project, we try to ensure the safety of the plant workers and give them the confidence to make the product line more efficient. By this, we can make the economy go up as well. Most of the workers lost their valuable lives due to these toxic gases. Aside from that, workers may confront a variety of health issues. The most harmful hazardous air

---

\* Corresponding Author: E-mail- [sdasanjeewa@uovt.ac.lk](mailto:sdasanjeewa@uovt.ac.lk)

pollutants are those that have a significant impact on human health or affect a large population. Health problems include cancer, allergies, asthma, a nervous system disorder, and birth defects. A few days or weeks after inhaling harmful air pollution, some people begin to experience health problems. One of the most typical first-time reactions is watery eyes. They may even be fatal, such as if they affect the lungs. The onset of other health problems may take months or years after a person is first exposed to a hazardous air pollutant. Cancer is an example of a health problem that manifests years later. We can't stop the emitting of toxic gases. The only one we can do is to avoid leakages. But due to some reasons, leakages may happen suddenly it is not suitable for the health of the workers. (Statista.n.d., no date) So we must ensure their safety because we can't express the value of human life. So this will be an excellent solution to overcome the above problem. This system can be applied to any place according to their requirement after changing the sensors.

### 3. METHODOLOGY

#### 3.1. Toxic Gas Detection

Sensors are used to detect toxic gases, as previously stated. All over the plant, sensor arrays have been installed with the primary goal of computing and alerting the environment when a value 'y' (near and less than 'x') is detected by the system. A higher-level threat detection notice should be issued if the value exceeds 'x,' instructing people to leave the area immediately to avoid any possible consequences. To warn the workers, an alarm is set off.

#### 3.2. System Behavior

Carbon monoxide, hydrogen sulfide, carbon dioxide, and ammonia are all detected by the system. The system detects these gases in the air using four sensors: MQ-9, MQ-136, MG-811, and MQ-137. For processing, an Arduino board with an ESP 8266 microcontroller is employed. Arduino perceives the world by accepting inputs from the four sensors and controls the actuators to influence its surroundings. An alarm and an LED light are employed as actuators. The actuators are set up to only light up or make a warning noise if the gases in the air exceed a certain threshold amount. The Arduino programming language and the Arduino development environment were used to create the entire system. This board has built-in Wi-Fi technology, which allows us to send real-time sensor data and monitor real-time dangerous gas levels from a distance. The components of the gas detection system are as follows:

- Sensors
- The ESP 8266 base microcontroller
- Alarm system

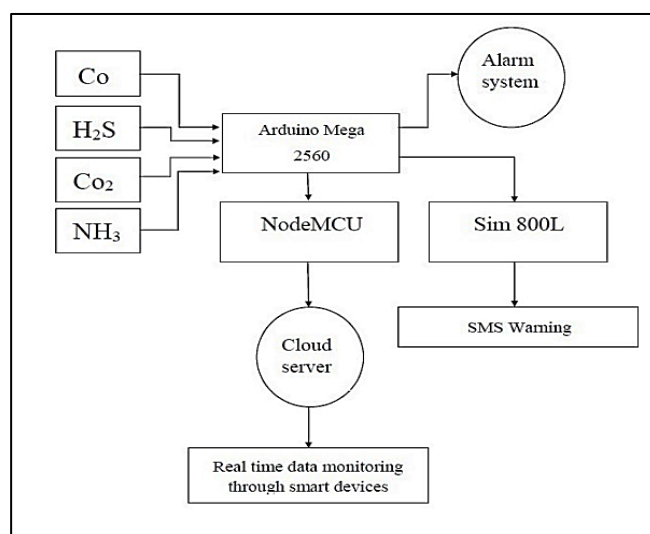

Figure 1: Block Diagram



### 3.3. Sensor Behavior

When exposed to clean air, the MQ-9 gas sensor's sensitive material, SnO<sub>2</sub>, has a lower conductivity. With the use of the cycle high and low temperature method, it detects CO even at low temperatures (heated by 1.5V). As the CO gas concentration rises, so does the sensor's conductivity. Cleans other gases that have been adsorb at low temperatures by heating them up (heated by 5.0V). The change in conductivity can be converted to the appropriate output signal of gas concentration using a simple circuit. (American, 2014).

The resistance of these sensors changes when they are exposed to certain gases since they are electrochemical sensors. Because of the heater inside, the sensor can react to gases and change its resistance value accordingly. Depending on the heater, a voltage of between 5 and 2 volts may be required, and the sensor works as a resistor, needing a load resistance (RL) to shut the circuit and provide a voltage divider that can be read from a microprocessor. For the output to be stable and have the qualities described in the manufacturer's datasheet, a warm-up period of 12 to 48 hours is required due to the heater. This varies by model. As a result, the connection component is simplified and their use is facilitated; all that is required is to feed the module with the sensor and begin reading it. We may adjust the threshold using a potentiometer, and then use the digital output to determine whether something is there or not. These modules include a digital output that functions internally using a comparator. Using Ohm's Law, we can derive a formula to find RS.:

$$I = V \div R \quad (\text{Eq: 01})$$

Which in our circuit is equal to :

$$I = VC \div (RS + RL)$$

$$RL = 47k\Omega$$

RO: sensor resistance in the clean air.

RS: sensor resistance at various concentrations of gases.

$$V = I \times R$$

$$VRL = [VC \div (RS + RL)] \times RL$$

$$VRL = (VC \times RL) \div (RS + RL)$$

So now we solve for RS:

$$VRL \times (RS + RL) = VC \times RL$$

$$(VRL \times RS) + (VRL \times RL) = VC \times RL$$

$$(VRL \times RS) = (VC \times RL) - (VRL \times RL)$$

$$RS = [(VC \times RL) - (VRL \times RL)] \div VRL$$

$$RS = [(VC \times RL) \div VRL] - RL$$

This formula will assist us in determining the sensor resistance values for various gases. The resistance ratio in fresh air is constant, as shown in the graph:

$$RS \div R0 = 3.6 \text{ ppm}$$

In order to calculate R0, we must first determine the value of the RS in the fresh air.

This will be accomplished by translating the sensor's analogue average readings to voltage.

Then we'll utilize the RS formula to figure out what R0 is. After the wiring configuration.

The graph's scale is logarithmic from 0 to 1. This means that on a linear scale, the gas concentration behaves exponentially with respect to the resistance ratio. This information is limited to concentrations between 100 ppm and 1000 ppm. However, despite appearances, there is no linear relationship between the resistance ratio and the gas concentration. To begin with, the lines will be handled as if they were straight. The ratio and concentration can now be linked linearly using a single formula. Even if the ratio value is outside the graph's boundaries, we can use this method to determine the gas's concentration.

The formula we'll use is the same as for a line but applied to a log-log scale. A line's formula is as follows:

$$y = mx + b \quad \text{Where:} \quad \text{(Eq: 02)}$$

y: X value

x: X value

m: Slope of the line

b: Y intercept

For a log-log scale, the formula looks like this:

$$\log(y) = m \times \log(x) + b$$

Note: the log is base 10.

To determine the slope, we must select two points from the graph.

Y interception Point Graph (20,1.2) y (40,1)

The formula to calculate m is the following:

$$m = [\log(y) - \log(y_0)] \div [\log(x) - \log(x_0)]$$

$$m = \log(1 \div 1.2) \div \log(40 \div 20)$$

$$m = -0.26303440583$$

Now for (30, 1.1)

$$\begin{aligned} \log(y) &= m \times \log(x) + b \\ \mathbf{b} &= \mathbf{\log(y) - m \times \log(x)} \\ \mathbf{b} &= \mathbf{\log(1.1) - (-0.26303440583) \times \log(30)} \end{aligned}$$

$$b = 0.42992639673$$

Now that we have m and b, we can find the gas concentration for any ratio with the following formula:

$$x = [\log(y) - b] / m$$

$$x = [\log(1.1) - 0.42992639673] / -0.26303440583$$

$$x = 1.47712$$

Where: on the air  $RS \div R0 = 3.6$

$$RO = 3.6 - 1.47712$$

$$RO = 2.2$$

### 3.4. Hardware Implementation

Table 1: Components and Software

Hardware Components		Software
Arduino Mega 2560	MQ-137 Sensor	Arduino
NodeMCU ESP8266	12v Alarm	Solidworks
MQ-9 Sensor	12v Fan	
MQ-136 Sensor	12v Relay Module	
MG-811 Sensor	16x4 LCD Display	

Data is collected, processed, and sent to a database using hardware components in the Internet-based real-time toxic gas detection system. This system's sensors include four different types. It was decided to use Arduino Mega 2560 and Node MCU ESP8266 to detect data from the sensors and transfer it to the internet. To send a text message to the person in charge, the SIM800L GSM module was utilised. The detector is equipped with a 12v alarm system to send out a warning.

### 3.5. Data Communication Methods

The ESP8266 has significantly more memory and runs at a maximum frequency of 160MHz. When working with an ESP8266 on an Arduino board, you'll want to have at least one of these libraries on hand. There's a chance there will be more. However, the given example is used in the majority of examples. When using this, our communication must be at least as good as Wi-Fi's. An access point (AP) / server and a client are required for communication. If you want to connect to a network, you use an access point (AP).

TCP and UDP are the two most commonly used protocols.

Using the Transmission Control Protocol, a server and client can exchange information without fear of data loss. Missing packets are identified and re-transmitted using "handshakes" (a series of flags and acknowledgements sent back and forth between the two parties). Additionally, the protocol prevents data loss caused by multiple packets being sent over the network at the same time by making use of all of these handshakes. There are data packets on their way.

In UDP, nothing happens except for one more data transmission (User Datagram Protocol). As a result, all handshakes were scrapped, saving the company a ton of money in the process. Some basic error detection and repair are included in UDP, but there is no repair functionality (the corrupted package is just dropped). It's risky to send information without first verifying that the recipient is available to receive it. Multiple packets can collide at the same time because data is delivered as needed by each side. Using UDP, all handshakes are omitted, allowing the "multicast" and "broadcast" features to be used. Broadcast sends data packets to everyone connected, whereas

multicast sends data packets to a predetermined group of members. Data transfer for streams that need to be received by a large number of people is drastically reduced as a result (e.g., sending a video feed to multiple receivers or sending the current time to multiple connected devices). (Codrey Electronics, no date). The sketches below have TCP and UDP in common: they show Are self-contained from any current Wi-Fi network. As a result, it will work even if you are not connected to the internet or routers.

- Are delivering ASCII data to the serial monitor to be printed.
- Are sending data from the Millis () function in order to figure out how fast the communication is.
- Are not tested for many clients (because of a lack of network gear at this time).

It is an acronym for Universal Asynchronous Receiver-Transmitter (or UART for short). Microcontrollers contain a variety of hardware peripherals such as this. The UART's goal is to create a serial binary stream from the data it receives and sends. An 8-bit serial device sends parallel data, which can be read by another device. It's possible to convert CPU parallel data by using a serial to parallel converter. The data is sent as modulating waves at a specific baud rate over the airwaves. Speedy communication is made possible by protocols such as SPI (serial peripheral interface) and USB (universal serial bus). When fast data transfer is not required, UART is used. A single transmitter and receiver are all that's needed for this low-cost mode of communication. For data transmission, only one wire is required, and the same is true for data reception. To connect it to a computer, use either an RS232-TTL or USB-TTL converter. (personal computer). A clock is not used by either RS232 or UART. That's the only thing they have in common.

For serial data transmission, the UART frame includes a start bit, one or more stop bits, and a parity bit. (Engineering Projects Hub, undated). Data is sent one bit at a time, sequentially, across a computer bus or communication channel in serial communication. It's the most common method of transferring data between computers and other electronic equipment. An indication of 5 Volts is given by the binary system, while a value of zero means that the voltage is low or that there is no voltage present at all. A computer or other device can communicate with the Arduino board using either of these methods. Serial ports, also known as UARTs or USARTs, are found on all Arduino boards. There are two digital pins on it: 0 (RX) and 1 (TX) (TX). To establish serial communication between the devices, connect them as shown below.

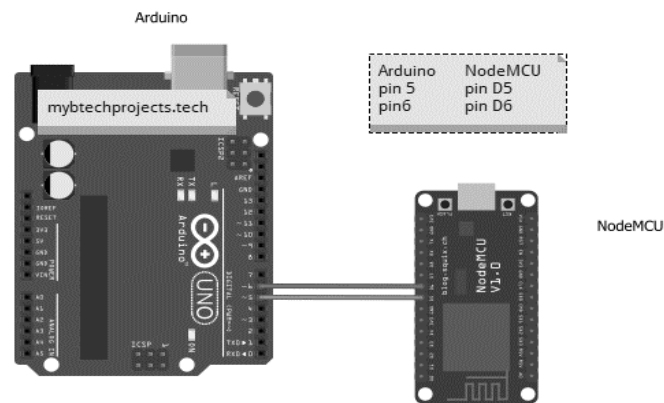

Figure 2: Serial data Connection

#### 4. RESULTS

Carbon monoxide, hydrogen sulphide, carbon dioxide, and ammonia levels will be monitored using separate sensors. The system design prototype is shown in Figure 3, below. Toxic gas levels were raised to dangerous levels, as shown in Figure 4, which depicts the SMS that was sent out as a result. Figure 5 depicts the final project setup. Figure 6 displays the gas values that are constantly being detected by the IoT platform's sensors.

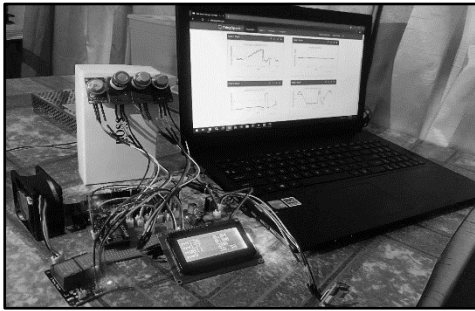

Figure 3: Complete experimental setup

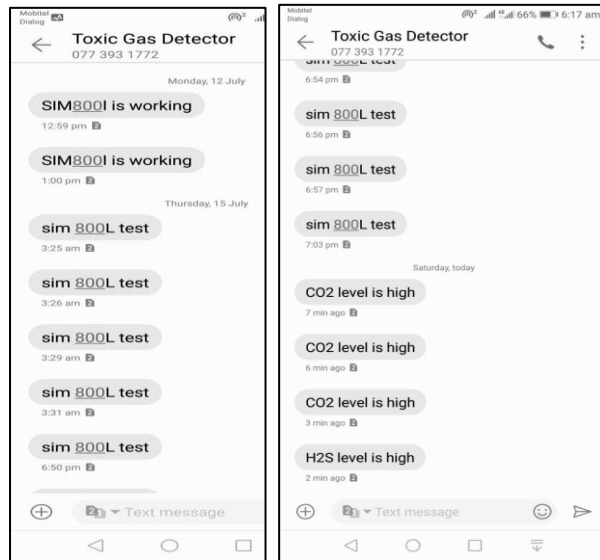

Figure 4: SMS alert results from different toxic gases



Figure 5: Complete final setup

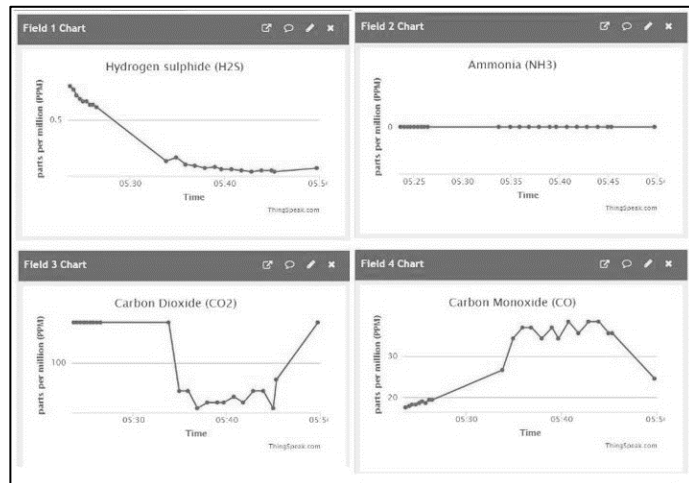

Figure 6: Graphical representation of different gases in IOT platform

#### 4. CONCLUSION

The end result of this project is a real-time toxic gas detector built on the Internet of Things. For plantation areas such as petroleum refineries, this was developed especially for use in the manufacturing process. This initiative helps workers feel less anxious, boosts their self-confidence, and ensures their safety on the job. Toxic gases in the working environment will be monitored by the Internet of Things system. Real-time monitoring at any desired location is more cost-effective than a traditional fixed monitoring system. The user interface shows the concentration of a poisonous gas in the workplace, so employees can decide whether it is safe to work there or not based on that information. The user interface is also cross-platform compatible, meaning it can be used on any computer running any operating system. The area covered by the alarm buzzer is about 100 square meters. People in the working area can be protected and their breathing air will be safe as a result.

#### REFERENCES

American, S. (2014) 'MQ-7 Datasheet', *Zhengzhou Winsen Electronics Technology CO.*, pp. 66–71.  
 Codrey Electronics, 2017 (no date) 'UART Communication Protocol - How it works?' - Codrey Electronics'. Available at: <https://www.codrey.com/embedded-systems/uart-serial-communication->

rs232/.

ENGINEERING PROJECTS HUB, 2018 (no date) 'Serial Communication between NodeMCU and Arduino'. Available at: <https://engineeringprojectshub.com/serial-communication-between-nodemcu-and-arduino/>.

Harper, A. and Croft-Baker, J. (2012) 'Carbon monoxide poisoning : undetected', *Age and Ageing*, 33(2), pp. 105–109. Available at: <http://ageing.oxfordjournals.org/content/33/2/105.full.pdf+html>.

Seaman. n.d. (no date) *H2S gas — what you need to know about hydrogen sulfide*. Available at: <https://www.blacklinesafety.com/blog/h2s-gas-need-know> (Accessed: 14 September 2021).

Statista. n.d. (no date) • *Sri Lanka - share of economic sectors in the gross domestic product 2010-2020 | Statista*. Available at: <https://www.statista.com/statistics/728539/share-of-economic-sectors-in-the-gdp-in-sri-lanka/>.

# Design and Implementation of Smart Accident Assist Service

M.Barathy\*, D.M.S.L. Dissanayaka, G.V.P.I. Weerathna, K.A.N.I. Pushpakumara

Department of Electrical and Electronics, University of Vocational Technology, Sri Lanka

## ABSTRACT

*Nowadays, the alarming rise of motor vehicle accidents has become one of the major concerns in Sri Lanka. Unconsciousness and disrespect towards traffic rules, reckless driving, the rapid growth of vehicles, etc. can be identified as major factors for this problem. The distress of the victims can be diminished if the notifying of accidents can be done on time. Often emergency supports cannot be provided immediately because of unawareness of the accident to the concerned persons. In this project, an automated system has been proposed to deal with this interrelated affair. The proposed system (SAAS) will help the wretched victims by informing the nearest necessary emergency supports. If somebody needs help in a motor vehicle accident, this will automatically send a text message to the 1990 Ambulance Service and the 119 Police Emergency Unit, which will assist victims. Therefore, this proposed system will be effective for developing countries like Sri Lanka to reduce the distress of the people.*

**Keywords:** Emergency Supports, Motor Vehicle Accident.

## 1. INTRODUCTION

Motor vehicle accidents are on the rise and have come to a peak in recent times with fatal accidents causing multiple deaths being reported almost daily in Sri Lanka. This is mainly because the person or group of people did not receive the necessary assistance at the right time rather than the accident itself. In the event of an accident, the person or group involved in the accident may not be able to call for others' help due to serious injury, fainting, or trauma. Traffic hazards and motor vehicle accidents have increased the suffering of people. One of the main reasons is the lack of emergency facilities available in our country. In most cases, when an accident occurs, relatives of that injured person get the news of his/her accident not in time and the emergency rescue teams reach late on the accident spot and the traffic in between accident spot and hospital sometimes increase the chances of death of the victim. Tracing the accident spot is the major issue faced by the emergency unit. Many patients have died in the past few years due to the late arrival of the ambulance to the scene of the motor vehicle accident. Almost every day, according to the news, people involved in motor vehicle accidents die due to delays in being admitted to the hospital. This is proved by checking the related CCTV footage. Besides, it is impossible to rescue a human who is drowning in water by stuck in the vehicle if the concerned persons are not notified immediately. Although many steps have been taken to reduce traffic accidents in our country, no successful steps have been taken to address the issue of delay in providing first aid to the injured parties. Therefore, the aim of this research is to provide a successful solution to this current problem. As a solution to these problems, a device called SAAS (Smart Accident Assist Service) has been offered.

## 2. PROBLEM STATEMENT

Nowadays, the death rate due to due to road accidents in Sri Lanka is very high. This is a major social problem for a developing and less populous country like Sri Lanka. Delayed hospitalization is the leading cause of death in motor vehicle accidents. This is because the ambulance services were unaware of the accident. That is, the accident occurred in an uninhabited area or people at the scene of the accident did not come forward to hospitalize the injured. When considering the current status of the research related to this, there are several kinds of research are done in several methods. But no successful design in this related has yet emerged in our country. Therefore, we carried out this project as a solution to the above problems.

---

\* Corresponding author: E mail - [baratyalahu@yahoo.com](mailto:baratyalahu@yahoo.com)

### 3. RESEARCH OBJECTIVES

The objectives of this study include the following:

- To reduce the number of deaths due to motor vehicle accidents.
- To identify the relatives of the victims and inform them as soon as possible.
- To expedite the ability to provide the necessary treatment to the affected parties (ex: If the victim needs blood, the blood group is entered in the SMS so that the required blood group can be prepared before being admitted to the hospital)

### 4. METHODOLOGY

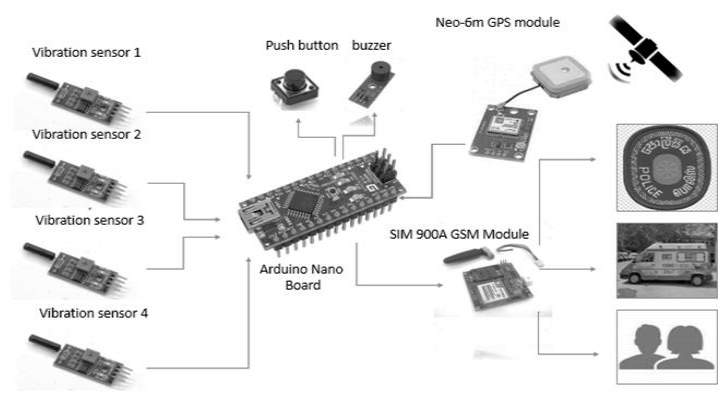

Figure 1: Components, Devices and Connections of the complete project

This section describes the components description and the software used for the study.

(i) **ARDUINO UNO:** The Arduino UNO is an open-source microcontroller board based on the Microchip ATmega328P microcontroller and developed by Arduino. The board is equipped with sets of digital and analog input/output (I/O) pins that may be interfaced to various expansion boards (shields) and other circuits. The board has 14 Digital pins, 6 Analog pins, and is programmable with the Arduino IDE (Integrated Development Environment) via a type B USB cable. It can be powered by a USB cable or by an external 9-volt battery, though it accepts voltages between 7 and 20 volts. It is also similar to the Arduino Nano and Leonardo.

(ii) **GPS Module:** GPS stands for Global Positioning System and is used to detect the latitude and longitude of any location on the earth, with the exact UTC. GPS module is used in our project to track the location of the accident. This device receives the coordinates from the satellite for each second, with time and date. In our project, we have used GPS module SKG13BL, which is an Ultra High Sensitivity and Low Power GPS Receiver Module

(iii) **GSM MODULE:** GSM/GPRS module is used to establish communication between a computer and a GSM-GPRS system. Global System for Mobile communication (GSM) is an architecture used for mobile communication in most countries.

(iv) **16\*2 LCD DISPLAY:** LCD stands for liquid crystal display. Character and graphical LCDs are most common among hobbyists and DIY electronic circuit/project makers. Since their interface serial/parallel pins are defined so it's easy to interface them with many microcontrollers. They are used to show the status of the product or provide an interface for inputting or selecting some process. Character LCD come in many sizes 8x1, 8x2, 10x2, 16x1, 16x2, 16x4, 20x2, 20x4, 24x2, 30x2, 32x2, 40x2 etc. We have used a 16x2 LCD for our project.



(v) **ADXL335 ACCELEROMETER:** An accelerometer is an electromechanical device that will measure acceleration forces. It shows acceleration, only due to the cause of gravity i.e. g force.

In this unit, four vibration sensors, one GPS module, and one normally open push button have been used as inputs of the system. One GSM module, one buzzer, and one indicator light as outputs of the system.

Once the vehicle faces the accident vibration sensors will detect the vibration and send that signal to the Arduino Nano board. Then the system will check the level of vibration is greater than or equal to the level which the researchers pre-entered into the program. If that requirement is fulfilled the sensor system will illuminate the indicating light and switch on the buzzer continuously for one minute. That period can be adjustable as per the requirement of the customer. Within that period, a driver can decide whether s/he needs or not help from accident assist agents. If s/he wishes s/he can manage the situation while pressing the push button. Then the system will stop the process. If the driver fails to press the push button, the system will send the message and correct location to the ambulance service, police emergency call Centre and another authorized person who pre-entered contact number to the system. In this case, the GPS module will help to control the unit to identify and to send the correct location.

In this case, one or two extra contact numbers and few details such as Blood group of the driver, registration number of the vehicle, insurance company, etc.can be added to the system as per the customer requirements.

## 5. RESULTS

To identify the triggering level of the vibration sensor the researchers have done some experiments. Different conditions have been used and the vibration sensor's output voltages have been used according to those conditions. To increase the accuracy, three tests have been done. Then we selected an average value of the readings for final analysis.

Table 1: Vibration Sensor Test Results

No	Observed moment	Observed sensor readings step 01 (mv)	Observed sensor readings step 02 (mv)	Observed sensor readings step 03 (mv)	Useful or not as an input signal
01	Engine starting	402	412	420	No
02	While engine running	379	382	390	No
03	Engine stopping	395	393	385	No
04	Door closing	325	311	365	No
05	Running on a carpet road	428	435	440	No
06	Running at low gear with high rpm engine	490	486	470	No
07	Sudden braking	378	357	315	No
08	Running on a rough surface road.	290	277	270	No
09	Hammering by a rubber hammer	130	158	102	Yes
10	Hammering by a steel hammer.	78	47	90	Yes

According to the above chart, according to the observations, last two conditions indicate the output voltage of a sensor is  $< 100$  mv. Therefore, researchers assume that the output voltage of the vibration sensor is  $\leq 100$  mv is the suitable triggering level for controlling unit. This level can be changed after the pre-test, according to the vehicle type.

While the finalizing the project researchers did some testing by making an accident in our demonstration car by knocking a rock. This was useful to adjust the triggering level of the system.

While the programming stage, few testing checks has been done to identify the location of the system. At this stage, the system took a few seconds to identify its current location. After that, it started to search its location according to the movements or travels.

The picture as shown in Figure 3 was captured when the end of the components installation and wiring of the smart accident assist service unit.

Figure 4 shows how the battery installation and wiring appeared in the demonstration car for our final demonstration. A 5Amph motorcycle battery and two power shutter motors has been used to drive the demonstration car.



Figure 3: Shows our team members are testing our final model location

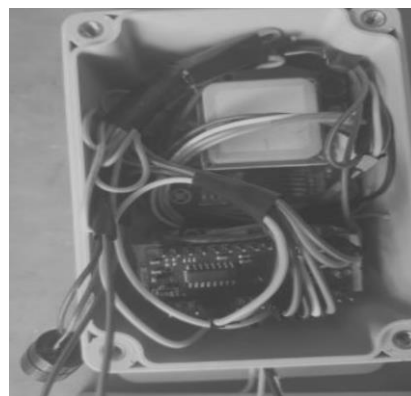

Figure 4: Shows the checking of GPS

The push button is fixed at top of the demonstration car for use to disable the system operation. That is the system method disabled by the driver of the car. If the driver decides s/he can manage the situation or if the driver requires any assistant services s/he can disable the system within the pre-entered period of the system.

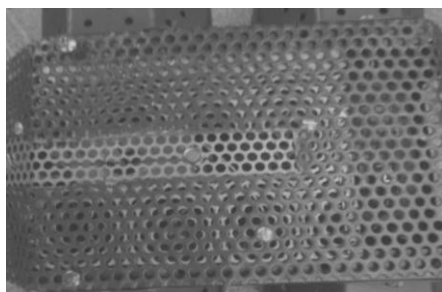

Figure 5: Shows the System disabling button at the center model

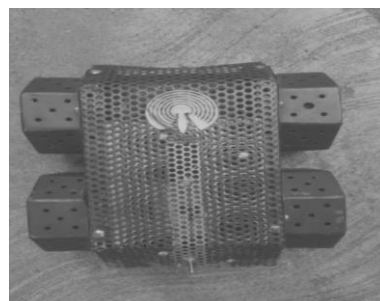

Figure 6: Shows our final designed

This was the end of the assembling of all components of the demonstration car. A toggle switch was fixed to switch ON/OFF the system and the travels of the demonstration car. And also one reminder

buzzer was fixed inside of the demonstration car to remind the driver to system disable as driver's wish. A demonstration of the model was tested by knocking a rock.

## 6. CONCLUSION

In this project, the main focus was to design and implement a smart accident assist service unit. Sometimes accidents take place in remote areas at night and serious injuries and deaths occur. The unfortunate situation of these accidents is that the delays of reaching of emergency services and traffic. Therefore, the researchers introduced a unit as a low cost, user friendly and an efficient device that can be easily attached and modified with any kind of a vehicle. Through this device, emergency services and traffic police can quickly respond and reach the location of such an accident.

The main target of this project is to reduce the number of deaths occurring from accidents due to getting late to first-aids, supporting activities, and medical treatments. Further, many extra benefits can be observed from this proposed device. One main thing is that, since the device is of low cost, it is highly suitable for the customers in a developing country of Sri Lanka.

Moreover, the ambulance services, traffic police, etc. can improve the efficiency of their services through this device. It is easy to identify the places in which serious accidents occur always and it will help them to take further actions to prevent or reduce such accidents. Another useful thing of this device is that it sends the message to other third parties. Therefore our family members and responsible persons can get correct information on time. Thus, self-confidence of the driver also improves through this device because the driver knows that the message will reach a selected person/group of people, if any accident occurs.

However, the network coverage of Sri Lanka affects this system. Because some areas of the country do not have good signal strength. Therefore, if this is implemented, we hope that systems will be updated by networking companies due to the expected higher number of users.

## REFERENCES

- Al-Mayouf, Y. R. B., Mahdi, O. A., Taha, N. A., Abdullah, N. F., Khan, S., & Alam, M. 2018. Accident Management System Based on Vehicular Network for an Intelligent Transportation System in Urban Environments. *Journal of Advanced Transportation*, 2018, 1–11. <https://doi.org/10.1155/2018/6168981>(accessed on 13<sup>th</sup> January 2021)
- Azeez, Raheem & Ogunrinde, Mutiat & Olaide, Adeleye. 2015. a web-based accident reporting and tracking system (artsy) using sensor technology. *International Journal of Advances in Engineering and Technology*. 8. 678-688.
- James, Amala. 2013. A seminar report on Accident Detection and Reporting System using GPS, GPRS, and GSM Technology.
- Jayathilaka, J., 2021, 07 02. Whether this system is available in European countries. (S. L. Dissanayake, Pushpakumara, & P. Weerathna, Interviewers)
- Kapri, Prashant & Patane, Shubham & Shalom, Arul. 2018. accident detection & alert system. 10.13140/rg.2.2.24034.89286.
- Kumarage, Amal., 2007. Impacts of Transport Infrastructure and Services on Urban Poverty and Land Development in Colombo Sri Lanka.
- L.P.Lokuranamuka., 2021, 07 03. Whether this proposed system is available in Japanese vehicles. (S. L. Dissanayaka, P. Weerathna, & Pushpakumara, Interviewers)
- Silva, B., 2021, 07 01. Whether this proposed system is available in vehicles of all countries. (S. L. Dissanayaka, P. Weerathna, & Pushpakumara, Interviewers)

# Design and Prototyping of Environment Sensing and Seed Sowing Robot for Agricultural Applications

W.M.T.M.Wasala<sup>\*1</sup>, M.KI.Marasinghe<sup>1</sup>, K.H.R.A.Senarathne<sup>1</sup>, S.P.A.R.S.Jayathilake<sup>2</sup>,  
M.W.P. Maduranga<sup>3</sup>

<sup>1</sup>Department of Mechanical and Manufacturing Technology, University of Vocational Technology, Sri Lanka

<sup>2</sup>Department of Electrical and Electronic Technology, University of Vocational Technology, Sri Lanka

<sup>3</sup>Department of Computer Engineering, General Sir John Kotelawala Defence University, Sri Lanka

## ABSTRACT

*This paper presents low-cost environmental sensing and seed sowing robot that could be used in agricultural fields. This robot can perform tasks such as real-time environment conditions monitoring and alerting users via an IoT server. The central controller is designed on ESP8266 microcontroller, DHT11 temperature-humidity sensor, FC 28 soil moisture sensor, motors, and motor controllers. This robot is also equipped with seed sowing capabilities. The chassis was designed using SolidWorks and manufactured appropriately. The performances of robots are presented in this paper.*

**Keywords:** Agricultural Internet of Things (AIoT), Autonomous Robots, Embedded Systems.

## 1. INTRODUCTION

Agriculture has a long and distinguished history that dates back thousands of years. It has also progressed due to several new systems, methods, technologies, and approaches. It employs about one-third of the global workforce. There are two forms of agriculture in Sri Lanka: non-plantation and plantation. Rice, maize, fruits, vegetables, and other non-plantation food crops are farmed on around 2.3 million hectares of agricultural land, mostly on small farms. Small-scale farmers contribute 80 % of total food production, with 1.65 million working on less than two hectares. Agriculture has been a major driver in poverty reduction, accounting for one-third of all poverty reduction over the last decade. Higher agricultural earnings helped alleviate poverty in rural Sri Lanka, which climbed by 57 % yearly from 2006 to 2013, whereas other sectors of the economy dropped faster. However, if agricultural production does not improve and the sector does not begin to modernize through diversification, commercialization, and value addition, income profits may not be sustainable. [1-3].

As humans progressed from hunters and gatherers to agricultural cultures, efforts have primarily centered on increasing plant yield and productivity through genetic changes, cultural or farming practices, managerial methods, or the development and implementation of plant protection measures. As a result, humans have begun to explore the potential by implementing various modern agricultural practices in the past and present centuries. In most cases, seed sowing is done by hand, which takes a lot of workforce and time. Furthermore, the plant thrives all year by intentionally altering and controlling the surrounding environmental variables within the limited facilities, such as temperature, CO<sub>2</sub> (carbon dioxide), humidity, light intensity, airflow, and nutrient delivery [4, 5]. Furthermore, compared to traditional (open-field) farming systems, such a system has a lower environmental effect and a higher crop output.

This project focuses on an integrated cloud and tracking line robot that monitors the environment utilizing the DHT11 sensor for temperature and humidity, a flame sensor for fire detection, and the soil moisture sensor for dangerous chemical detection. The robot's system was created and designed with a low-cost budget. In addition to sensing, the robot is also capable of doing seed sowing. The

---

\* Corresponding Author: E-mail - [tushanwasala@gmail.com](mailto:tushanwasala@gmail.com)

prototype of the robot was designed using SolidWorks and manufactured. Finally, the robot was tested in an actual agricultural field, and the results are discussed in this paper.

## 2. SYSTEM DESIGN

The connectivity of hardware modules, protocols and software tools are required for the designing of agricultural robots. This section explains the building blocks of the systems. The proposed farming robot's block diagram is shown in Figure 1.

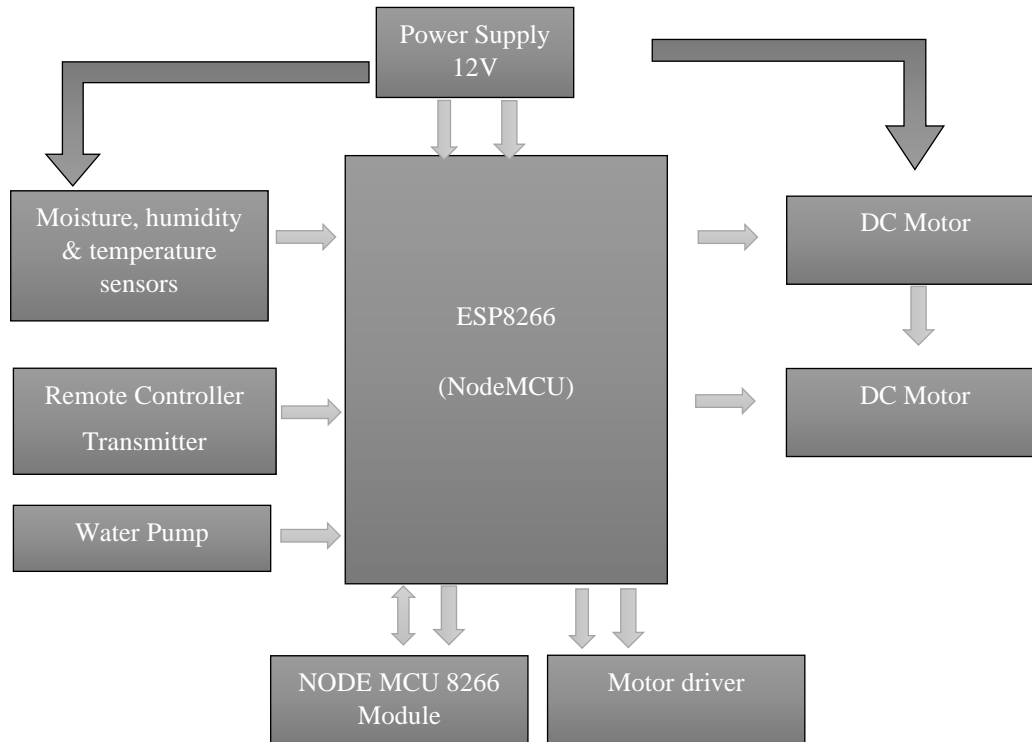

Figure 1: System Overview

### A. Main Controller Circuit Design

ESP8266 microcontroller is the primary controller of the developed robot [4]. The agricultural robot is a self-contained robot controlled via a wireless remote between the remote control transmitter and the robot. The robot for farming purposes is an autonomous robot controlled remotely through a wireless remote between the remote control transmitter and the robot. All the operations of the robot are managed through a remote control transmitter. The remote control transmitter is used to control every procedure of the robot. The receiver kit is placed on the robot that receives signals from the remote controller transmitter and sends these signals to the microcontroller to process tasks.

### B. Power Supply Design

The primary controller circuit is powered by a 12V DC battery, with a voltage regulator for regulating the controller's voltage input. The driver circuit receives a 5V supply from the microcontroller. DC motors cannot be actuated with this source. As a result, the driver circuit converts 5V to 12V and runs the motors connected to it.

### C. Motor Controller Design

In this design, the researchers have used several motors and motor controllers as the wheels of the autonomous robot and also to implement the seed sowing mechanism. The bidirectional motion is controlled by the L293D motor driver 1 circuit, which also receives signals from the microcontroller. DC motors control the robot's wheel mobility and other operations. The microcontroller sends signals like 00,01,10,11. When indications such as 00 or 11 appear, the motor is turned off, and the robot does not move. If the signal is anything other than 01, the motor will rotate backward. Otherwise, the motor will rotate in a forward direction (when the signal is 10). Two DC motors are controlled by the

L293D motor driver two circuits. A line marker is used to draw a line where seeds will be distributed. A single DC motor powers the line marker. Only one line is designated throughout the robot's path, and the pit marker has only one tooth. Seeds for seeding are stored in a cuboid-like structure called a seed storage device.

Seeds from the cuboid-like structure are dispensed for seeding through a seed wheel during the seed sowing process. The seed falls into the gap as a result of the seed wheel. A motor and a tube with a hole through it make up the seed wheel assembly. And is connected to the shaft of the motor. The axis of the seed wheel rotates as the engine continues to rotate. A leveler is used to seal and level the soil after the sowing operation. Another capability of the robot is the ability to apply water. Water is stored in the water tank. The water is pumped and piped to the robot's front, where it is then distributed.

#### D. Chassis Design

We used SOLIDWORKS for design purposes. Figure 2 denotes the main steps of the chassis design.

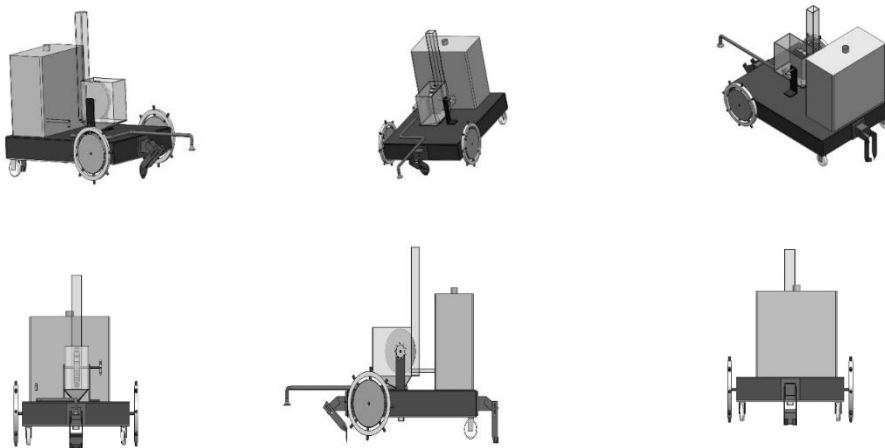

Figure 2: SOLIDWORKS Drawings

#### E. Sensor-based System Design

The system consists of a DHT 11 temperature/humidity sensor and a soil-moisture sensor. The connector of each sensor to the NodeMCU board is shown in figures 3 and 4, respectively. 5v comes to require separate power from the supply and ground. Soil moisture sensor data pin is directly connected to NodeMCU board PIN 3. The soil moisture sensor provides analog output voltage via ADC on the NodeMCU board.

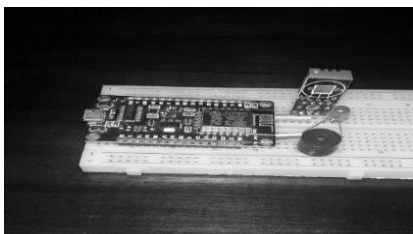

Figure3: NodeMCU - DHT11 Connections

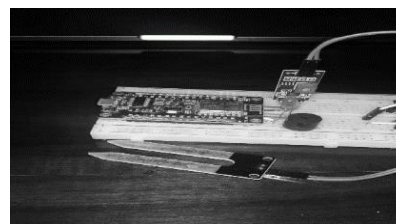

Figure 4:NodeMCU-Soil moisture sensor

#### F. Firebase Cloud Connectivity

Google Firebase is a fully managed solution for connecting and controlling IoT devices in a safe manner. IoT devices can use per-device public/private key authentication to connect to Google Cloud and exchange data using the MQTT or HTTP bridge. A Cloud Pub/Sub event stream is used to broadcast incoming device data [9-10]. The three Node MCU boards are connected with Firebase via the broadband router. All sensor data will transmit to the Firebase simultaneously with a fixed sampling rate.

Sensors can be used at every node of our project. The collected sensor data are activated locally. Firebase can be used to store data in our program cloud. Further, this data is stored in the cloud and can be easily viewed by customers by logging into their client's accounts.

### 3. RESULTS

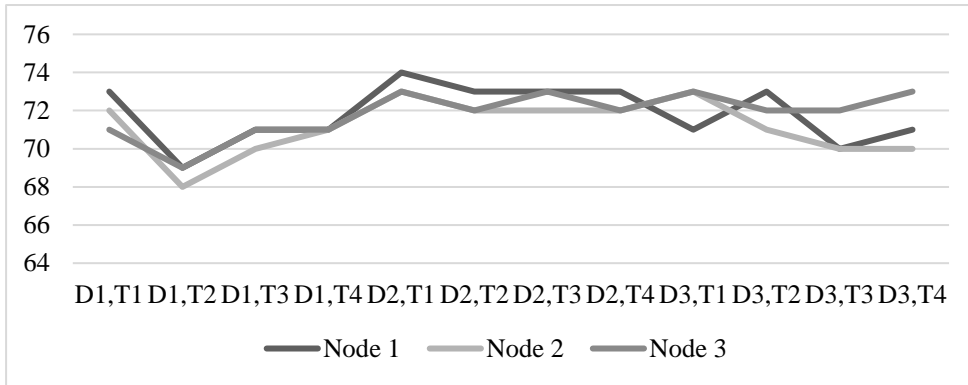

Figure 6: Humidity Time Series

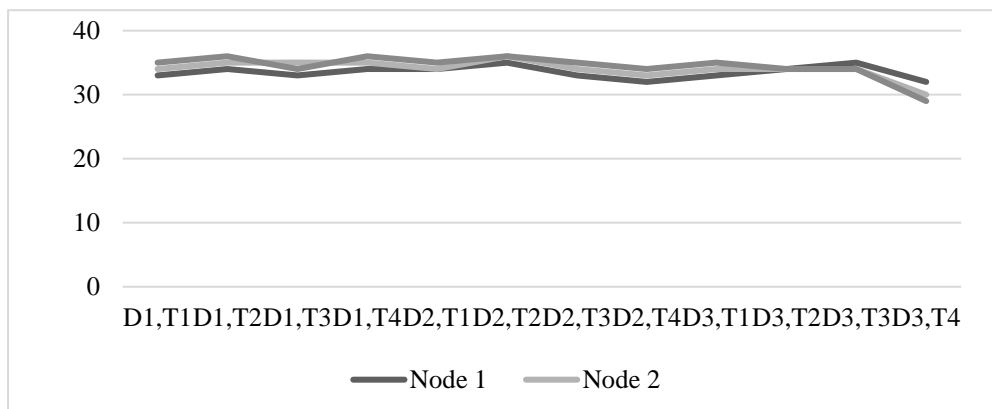

Figure 7: Temperature Time Series

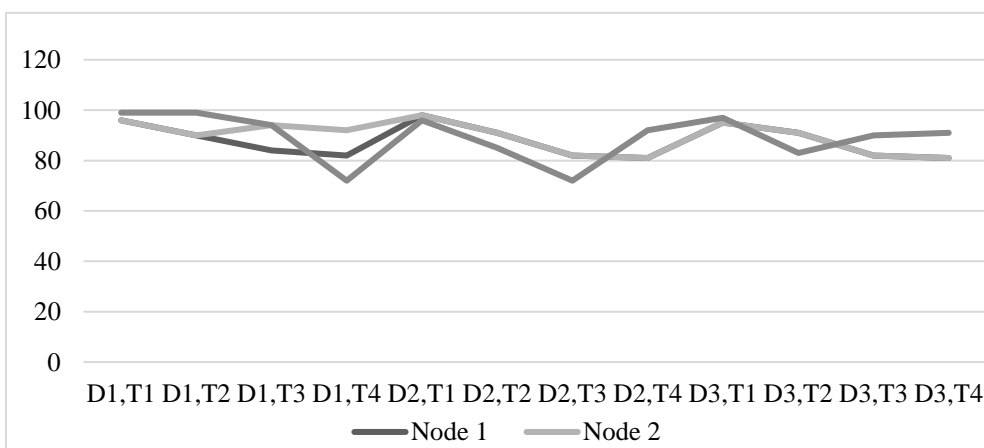

Figure 8: Moisture Level Time Series

As per figure 6, humidity measures the air's water vapor content at a given time. The amount of moisture in the air is compared to the maximum amount of moisture that the air can hold simultaneously, and the result is given as a percentage. The graph to the right shows the time and

humidity (%) readings. The average humidity is 71.5%. Figure 7 shows the temperature of the typical weather condition. The temperature sensor nodes monitor the Firebase. As per the results, the average temperature was 34.5Celcius in the tested field.

Moisture is defined as the presence of a liquid, most commonly water, in small amounts. Water can be found in small amounts in the air (humidity), meals, and some commercial products. Figure 7 shows the time and moisture readings. Where we observed that the average moisture was 91.5% in the testing field

Figure 9 shows the final overview of the prototype. The implemented robot is moving in the field using the RF remote controller. The pit marker has a single tooth, and only one cable is marked along the robot's path. The seed wheel causes the seed to fall into the gap. A leveler is used to seal and level the soil after the sowing operation. The water tank stores water. The mini submersible water pump pumps the water.

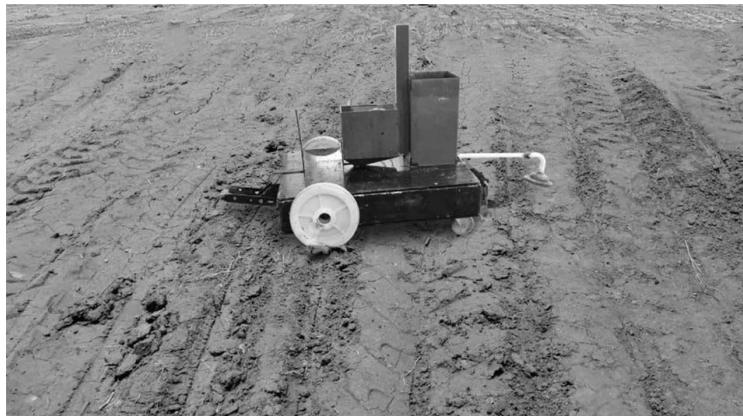

Figure 9: Final view of the prototype.

#### 4. SUMMARY

In this paper, a prototype for an environment sensing robot used for agricultural applications has been introduced. This robot's primary functions include real-time temperature measuring, soil moisture level measuring, and humidity measuring. Moreover, also capable of placing seeds on the soil. This primary design controller is the ESP8266 microcontroller. All the sensors are arranged inside the robot, and sensor reading can be accessed via a Fire Base IoT server. Test runs have been conducted with the prototype, and results of sensor parameters were reported.

#### REFERENCES

- Jirapond Muangprathuba, Nathaphon Boonnama, Siriwan Kajornkasirata, Narongsak Lekbangponga, Apirat Wanichsombata, Pichetwut Nillaor "IoT and agriculture data analysis for smart farm" *Computers and Electronics in Agriculture Journal* 2019.
- Chandana R, Nisha M, Pavithra B, Sumana Suresh, Nagashree R N "A Multipurpose Agricultural Robot for Automatic Ploughing, Seeding and Plant Health Monitoring" *International Journal of Engineering Research & Technology (IJERT)* 2020.
- S. Chandra, S. Khan, B. Avula, et al., "Assessment of total phenolic and flavonoid content, antioxidant properties, and yield of aeroponically and conventionally grown leafy vegetables and fruit crops: a comparative study," *Evidence-Based Complementary and Alternative Medicine*, vol. 2014, Article ID 253875, 9 pages, 2014.
- N.T Jayathilaka, RMCAB Rathnayake, M.W.P Maduranga "Design and Experimentation of a Wi-Fi-based Low-Power IoT System for Environmental Conditions Sensing" *International Journal of Computer Applications*, Vol 174, February 2021.
- M. S. Tajwar Haque, K. Abdur Rouf, Z. A. Khan, A. Emran and M. S. Rahman Zishan, "Design and Implementation of an IoT based Automated Agricultural Monitoring and Control System," 2019



International Conference on Robotics, Electrical and Signal Processing Techniques (CREST), 2019, pp. 13-16, DOI: 10.1109/ICREST.2019.8644212.

Vishnu Prakash K, Sathish Kumar V, Venkatesh P, Chandran A "DESIGN AND FABRICATION OF MULTIPURPOSE AGRICULTURAL ROBOT" International Journal of Advanced Science and Engineering Research, Volume: 1, Issue: 1, June 2016.

Kavita Zole<sup>1</sup>, Sanghasevak Gedam<sup>2</sup>, Aditya Dawale<sup>3</sup>, Kiran Nikose<sup>4</sup>, Jayant Hande "AGRICULTURAL ROBOT" International Research Journal of Engineering and Technology (IRJET) Volume: 05 Issue: 02, Feb-2018

Sanket Salvi, Pramod Jain S.A, Sanjay H.A, Harshita T.K, M. Farhana<sup>4</sup>, Naveen Jain, Suhas M V "Cloud-Based Data Analysis and Monitoring of Smart Multi-level Irrigation System Using IoT" International conference on I-SMAC (IoT in Social, Mobile, Analytics, and Cloud) (I-SMAC 2017) C. S. Patel and J. A. Gaikwad, "Design and Development of IOT Based SMART water distribution network for Residential areas," *2019 International Conference on Communication and Electronics Systems (ICCES)*, 2019, pp. 2019-2023, doi: 10.1109/ICCES45898.2019.9002053.

S. Roy, "IOT Enabled Security System for Android users," *2018 International Conference on Recent Innovations in Electrical, Electronics & Communication Engineering (ICRIEECE)*, 2018, pp. 2312-2317, doi: 10.1109/ICRIEECE44171.2018.9008874.

# Design of Automatic Sanitizer for Door Handles and Push Buttons

S.R.M.P. Seneviratne<sup>1\*</sup>, Ravindra Koggalage<sup>2</sup>, K.A.H. Hasaranga Rasanjana<sup>2</sup>,

H.A.J. Srimal<sup>3</sup>

<sup>1</sup>Department of Quantity Surveying, University of Vocational Technology, Sri Lanka

<sup>2</sup>Department of Electrical and Electronics, University of Vocational Technology, Sri Lanka

<sup>3</sup>Department of Mechanical and Manufacturing Technology, University of Vocational Technology, Sri Lanka

## ABSTRACT

*It is possible for certain viruses such as the COVID-19 virus to exist on different surfaces up to 24 hours or even a number of days on metal surfaces. Any high contact surfaces such as door handle posture a threat to unfold COVID-19 virus spreading by causing a surface to exchange the virus by touching. Elements such as door handles and push buttons can be considered as highly probable media of spreading viruses causing infection via touching such surfaces. On the other hand, the unfolding of the COVID-19 virus has been identified as frequently modifying into new variants so that it is difficult to control the speed of spreading using the existing facilities with traditional methods such as manual cleaning of such surfaces wherein the public places many making interaction. The need to have safety mechanisms to minimize the health risks of spreading the diseases is increasing accordingly. This research focuses on providing an automatic, low-cost and user-friendly sanitizing device that can be used to clean the frequently touching areas such as push buttons in lifts, door handles, and locks to minimize such spreading risks. The proposed device is capable of sanitizing the frequently used surfaces automatically with the application of an ultrasonic distance sensor and an Arduino-Nano microcontroller board hence safeguarding the users in order to minimize the spreading of viruses and bacteria such as the COVID-19 virus in society.*

**Keywords:** Automatic sanitizer system, Door handle, Hand sanitizers, Push button sanitizers, Ultrasonic distance sensors

## 1. INTRODUCTION

The recent spreading of the COVID-19 virus modified the method the society makes interaction at high interaction surfaces for example door handles, fuel pumps, pin pads, which posture a high danger to the unfolds of COVID-19 virus. To resolve this issue, an automatic system is needed, which is capable of routinely sanitizing the touchable surfaces after the usage of each user of the element. The system created applies a mist of cleansing for slaying microorganisms on the interaction surface and rapidly evaporates leaving a sanitized floor for the subsequent user.

The unfold of the COVID-19 virus is identified as demanding modified directives to reduce the risk of spreading. On the other hand, the increase of spreading the COVID-19 virus is influentially caused by transmitting it via touching surfaces such as door handles, pushbuttons as a media. Therefore, there is a need to have safety mechanisms to clean such surfaces from viruses to minimize health risks of spreading diseases such as COVID-19 among users, which is the problem of the study as well. The objectives of this study are:

- i. To study the mechanisms of smart hand sanitizers for entrance doors and push buttons connected to the door to controls
- ii. To design a mechanisms of smart hand sanitizers for entrance doors and push buttons

---

\* Corresponding author: E mail - [srmpseneviratnaunivotec@gmail.com](mailto:srmpseneviratnaunivotec@gmail.com)

## 2. LITERATURE REVIEW

### 2.1 Usage of Hand Sanitizers

Covid-19 pandemic as a global pandemic outburst identifies the importance of hand hygiene as a core preventive measure of spreading the disease as also counseled by the WHO (World Health Organization). It was advised to wash the hands by water with soap regularly, or using any hand sanitizing technique. Handwashing is identified as helping to prevent the spreading of diseases through contact. (Edozie E., Janat W., Kalyankolo Z., 2020).

The common remedy for the prevention of spreading of Covid-19 virus has been proposed with three common options: The usage of Alcohol-based hand sanitizers, usage of non-alcohol based hand sanitizer, and the frequent hand washing with commercially available liquid, bar, or foam soap (<https://www.cdc.gov>, 2020) prevention of spreading of the virus. Proper handwashing must be used to remove bacteria from hands. Application of alcohol-based handwashing as it is more resistant than handwashing or soap and water. It can effectively reduce hand bacteria (Edozie E., Janat W., Kalyankolo Z., 2020).

Hand sanitizer gels are liquid gels or foams and are often used to reduce the source of infection. Antiseptics are designed to kill bacteria on skin, objects, and surfaces (Edozie E., Janat W., Kalyankolo Z., 2020). The risk of infection occurs as more people interact by touching a number of pump handles. (Lee J et al., 2020) The application of a touchless automated hand sanitizer dispenser can be used to play a key role in reducing transmissible diseases. (Arnab Das A., Barua A., Mohimin A., Abedin J., Khandaker M.U., Al-mugren K.S., 2021)

Alcohol-free or Non-flammable sanitizer is a more positive in use as rinse-free hand sanitizer as a method for normal hand washing. (Dyer D.L., Gerenratch K.B., Wadhams P.S., 1998). The Alcohol-based hand sanitizers exterminate viruses rapidly, which deals with related diseases on respiratory and gastrointestinal terms. (Thomas J. Sandora et al., 2005). It has been identified as the hand sanitizers of Ethanol-based as a capable option of dipping transmission of transferrable viruses. (Marcinga D.R., Sattar S.A., Jaykus L.A., Arbogas J.W., 2020)

### 2.2 Application of Alcohol Based Hand Sanitizers

Hand hygiene is very important. This is because direct contact with airborne microorganisms through coughing and sneezing can easily cause contamination (Jing J.L.J., Bose R.J.C., McCarthy J.R., Tharmalingam N., Madheswaran T, 2020).

Especially like an epidemic, it is important to stop the chain of infection through proper manual disinfection, to be achieved by isolation from exposure and strict infection control measures to maintain proper hand hygiene in public places (Jing J.L.J., Bose R.J.C., McCarthy J.R., Tharmalingam N., Madheswaran T, 2020)

Infections such as COVID-19 are strategically distressed by the usage of tools as good Hand hygiene as it can reduce the outbreak of infections. Hand sanitizers are considered in this stage as an easy, versatile, and lower impact on the skin. Therefore, hand rub gels based on alcoholic and alcohol-free are identified as competitive in the market. (Villa C., Russo E., 2021)

In disinfectant qualities of antiseptic agents and hydrogels play a vital part in gaining steady formulations easy to disperse, and pleasant at the skin with good performance. (Villa C., Russo E., 2021). Studies conducted to investigate the effectiveness of alcohol-based hand sanitizers have added that the use of alcohol-based hand sanitizers can reduce infection rates, indicating relevant tools needed for infection control. (Hilburn J, Hammond C.S., Fendler E.J., Groziak P.A., 2003)

Hand sanitization accomplishment solely is a result of effective hand sanitizers come in many forms and shapes, such as antibacterial soap, Alcohol-based hand sanitizer or water, and often the most effective alcohol-based hand sanitizer.

With an alcohol content of 62-95%, it is a micro-organism capable of suppressing bacteria by focusing on the antibacterial effect of alcohol-based hands against the coronavirus. (Jing J.L.J., Bose R.J.C., McCarthy J.R., Tharmalingam N., Madheswaran T,2020)

### **2.3 Demand for Hand Sanitizers at Covid-19 Virus Outbreak**

WHO guidelines are provided instructions to be hygienic or sanitize hands repeatedly in order to decrease the risk of spreading and infection over diseases contaminated by contact.

A viral disease like Viruses COVID-19 is highly exchangeable in touch and by contact. (Gupta A., Kumar R, Nirjuli U.P, Pradesh A, 2020) The demand for hand sanitizers has heaved as per the spread of the coronavirus wide-spreading around the world. (Lee J et al., 2020). The provision of sanitizer by bottle and storage, which is a usual application needs manual usage. (Gupta A., Kumar R, Nirjuli U.P, Pradesh A, 2020)

### **2.4 Automatically Pumped Hand Sanitizers**

Certain hand sanitizers developed can be pumped automatically. Yet, since sanitizer bottles and pump devices were intended to facilitate the same manufacture, consumers have to again buy the container of liquid for hand sanitizer. (Lee J et al., 2020)

### **2.5 Automatic Hand Sanitizer System Mechanisms**

Lee J et al has suggested an automatic handwashing system that can be used with a variety of disinfectant containers and with an automatic hand washing system, when bringing hand close to the sensor of devising the handwashing tank is sucked in. (Lee J et al., 2020). Gupta A., Kumar R., Nirjuli U.P, Pradesh A., has proposed an invention design of a touch-less sanitizer mechanism reducing the risk over the contact. The mechanism of the system has an ultrasonic sensor that sends the signal to the microcontroller, as at a controller processes sense the sensor data & actuate the pump and solenoid valve. Accordingly, the sanitizer liquid will dispense through a mist nozzle (Gupta A., Kumar R., Nirjuli U.P, Pradesh A, 2020)

Lesmana J., Halim A., Irawan A.P identify a prototype of an automatic hand sanitizer to discharge sanitizing liquid without pressing the nozzle includes the change from a rotational movement towards a translation measure. The VDI 2221 method was applied at the strategy uses Arduino Nano microcontroller, in this the servo motor used for motor thereof the ultrasonic sensor at sensing the change of postures at the environment, rack/pinion scheme at of pressing the nozzle from hand sanitizer. (Lesmana J., Halim A., Irawan A.P, 2020) Srihari M. M. invented a hand wash sanitizer of automatic, as a sanitizer liquid pump by motor with detection of an IR Sensor sensing the human hand detection. The mechanism with the motor, as it is connected to a timer delay setup of RC with a tube related to a reducer to regulator the flowing of fluid of sanitizer. With Control LED's system, with the working mode of battery is in use and as the Red LED for charging mode of Battery and the Green LED for full charged mode with On/ Off switch control. (Srihari M. M, 2020)

Lesmana J., Halim A., Irawan A.P identify a prototype of an automatic hand sanitizer to discharge sanitizing liquid without pressing the nozzle includes the change from a rotational movement towards a translation measure. The VDI 2221 method was applied at the strategy uses Arduino Nano microcontroller, in this the servo motor used for motor thereof the ultrasonic sensor at sensing the change of postures at the environment, rack/pinion scheme at of pressing the nozzle from hand sanitizer. (Lesmana J., Halim A., Irawan A.P, 2020) Srihari M. M. invented a hand wash sanitizer of

automatic, as a sanitizer liquid pump by motor with detection of an IR Sensor sensing the human hand detection. The mechanism with the motor, as it is connected to a timer delay setup of RC with a tube related to a reducer to regulator the flowing of fluid of sanitizer. With Control LED's system, with the working model of battery is in use and as the Red LED for charging mode of Battery and the Green LED for full charged mode with On/ Off switch control. (Srihari M. M, 2020) Sunlight and vehicle sound are the key problematic of ultrasonic infra-red-based dispensers. (Arnab Das A., Barua A., Mohimin A., Abedin J., Khandaker M.U., Al-mugren K.S., 2021) when deployed in busy public places. Ananda Ajayan A. from Beevi has developed an inexpensive automatic disinfectant dispenser that uses ultrasound or infrared sensors to detect the presence of hands. K.S. They use ultrasonic sensors for identification. Ultrasonic sensors are more expensive than infrared sensors and require a microcontroller to function smoothly. They also found a problem with infrared sensors, as their sensitivity depends on the intensity of the sun. The solution identified is to change the traditional design of the infrared sensor into specific frequency.

The LED sends out infrared pulses of a certain frequency. Then, instead of a photodiode, an infrared receiver with a certain frequency is used, which only receives infrared pulses of a certain frequency, which solves the problem of sunlight. The battery life of this design is 24 hours and can be charged via the flow regulator, liquid level detector, and portable charger. (Ananda Ajayan A., Beevi. K.S., 2020). A Dispense sanitizer was developed by Arnab Das A., Barua A., Mohimin A., Abedin J., Khandaker M.U., Al-muggen K.S. with laser-based detecting device as automatic touchless process other than conventional ultrasonic and infra-red-based dispensers with problems at the environmental effect as with sunlight and noise.

The AT-mega328p Arduino microcontroller circuit uses a laser sensor (LDR) as a laser sensor for access to the breadboard-based distribution system, and the value of the LDR sensor decreases rapidly if it is blocked by a human hand. Compared to other dispensers on the market, this device has proven to be more efficient and cost-effective. (Arnab Das A., Barua A., Mohimin A., Abedin J., Khandaker M.U., Al-mugren K.S. 2021)

Harshil Sathwara H., Vaghela P., Joshi S developed an automatic hand cleaning dispenser with a non-contact temperature gauge. The device is equipped with a 12V, 1A adapter, LM7805 voltage regulator, two Arduino Uno, ultrasonic sensor, MLX90614 infrared temperature sensor, L298 motor driver, disinfectant container, DC submersible pump, display with I2C module, and with a buzz developer. A solar panel is used to power the device through a rechargeable DC battery. It connects to AC power via a 12V, 1A adapter for cost savings and a more compact design. Room temperature was measured together with the respondent's body temperature. The device is expected to reduce the impact of the risk of contracting coronavirus. (Harshil Sathwara H., Vaghela P., Joshi S, 2021)

## **2.6. Automatic Hand Sanitizer for Door Controls**

Edozie E., Janat W., Kalyankolo Z have developed an inexpensive intelligent hand sanitizer on the bank, school, and hospital gates that are equipped with microcontroller-based door controls, electromagnetic locks, and ultrasonic sensors. The smart hand sanitizer is on the front door and is connected to the door to control the door. Works with the ultrasonic sensor to check if there is a hand under the disinfectant and calculates the distance between the disinfectant outlets. If the distance is less than 10 cm, the microcomputer is notified to turn on the servo motor, instruct the disinfectant, and press. Use the electromagnetic lock to turn off the power (open the door), turn on the green LED, and display "Front door open". Then the second servo motor opens the front door (Edozie E., Janat W., Kalyankolo Z, 2020).

## **2.7 Placing of Automatic Sanitizer**

Location of a Manual sanitizer is complex use in realistic claims. A manual sanitizer location results in inconsistent multiple-sanitization errors and duplicated code. (Welearegai G.B., Hammer C., 2017). An automatic method for sanitizer location which is fully automatic. A run-time taint chasing

system was applied in tracking the cause at cost for suitable sanitization. (Livshits B., Chong, S., 2013)

Welearegai GB, Hammer C. Analyzing program data flow through static analysis and optimizing automatic disinfectant placement to reduce the number of locations needed for disinfection, suggest. Disinfect nodes that share different path priorities, investigating the dataflow program through static analysis which is the location of the disinfectant. This provides the same sterilization protection as the previous method which reduce the amount of disinfection and reduce the number of sterilization errors. (Welearegai G.B., Hammer C.,2017)

### 3. METHODOLOGY

In this study, an enhanced automatic sanitizer Mechanism is proposed to decrease the events of spreading the COVID-19 virus while allowing an automated sanitation mechanism with the conventional touchable elements such as Door handles and Push buttons with sanitization equipment. Literature reviews about existing works both locally and internationally were conducted to identify the existing work and its shortcomings. The new design is done to automate the process using sensors and controllers.

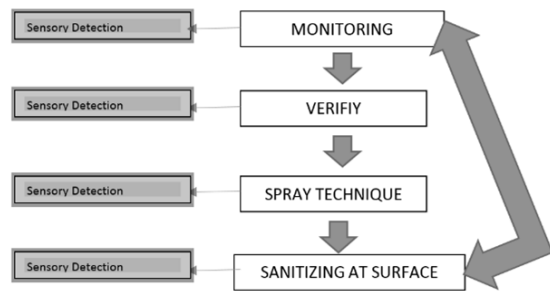
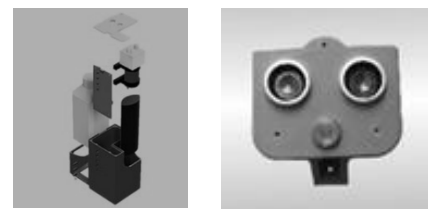

Figure 1: Sensory process of the entire design

In the Design Sanitization of the surface is done by a spraying technique. The spraying technique is a result of verification over the sensory technique happen after Monitoring the process with connection to the sensing of spraying time monitoring at the surface. The process is though being a cyclic one. Figure 1 elaborates the entire design and the process.

#### 3.1 PHYSICAL DEVICE DESIGN

The main aim at the design is to disinfect surfaces through covering a cleansing liquid automatically at the surface. Initial requirement is to detect the surface once used to supply the cleansing solution. The pump used need to be open immediately to the nozzle mister permitting in supplying a spraying with a high-pressure. Activated pump attracts the cleansing liquid from the container for a mist. Volume is managed obligation cycle of the pump.



(a) Pump assembly (b) Sensor nozzle assembly

To do this automatically, a sensor has been used to decide when to sanitize the surface. Kinds of sensors have been measured; however, ultrasonic sensors had been selected to use due to less cost and availability. Ultrasonic distance sensors have the advantage of having extra compactness than ultrasonic sensors. As depicted in Figure 2, the entire design consists of a pump assembly and sensor nozzle assembly.

Figure 2: Entire system assembly

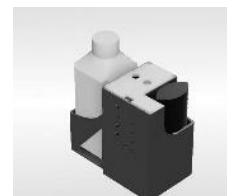

Figure 3: Modeling Frame

An enclosure designed to reside these parts are manufactured using the 3D printer in realistic print time. A hole for the cleansing fluid with battery has been additionally protected in the covering design. The system was established by using the zip draws or screws to fix into hole slots of the key to cover.

Manufacturability was considered to identify the good market, it was designed with ease and assembly in mind. Wires and hoses should appropriately connect. Screw terminals developed for electrical connections with the prototype. Hoses and nozzle epoxied and pressed to match to the pump, which would increase the speed of assembly.

The circuit cover is equipped with an insertion hole for the back of the board, and only needs to attach the two pinnacle mounting screws. The pump requires a bracket formed by the "cup" to slide into a soft interference fit. Connect the gable panel with four screws to complete the release assembly. Higher sessions require three screws to secure the trim panel in place. For mass production, snap fittings and cyanoacrylate glue (CA glue or super glue) can be the better answer to reduce meeting time and cost. The 3D rendering shows an exploded view of the device.

### 3.2. Circuit and PCB Design

Circuit and PCB design includes Arduino-Nano, ultrasonic sensor, diaphragm pump, push button and light emitting diode.

Arduino-Nano is one kind of microcontroller board and it is designed by means of arduino.cc. It can be constructed with a microcontroller like atmega328P.

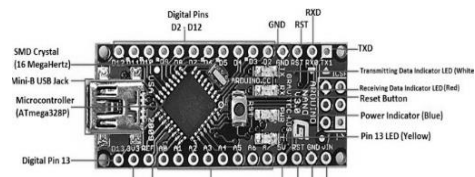

Figure 4: Arduino-Nano

Ultrasonic sound waves are vibrations at a frequency above the range of human listening to (>20kHz) that can travel through a range of mediums (air or fluid), used to measure flow patterns, observe objects, operate attention analysis, and measure distances and aware of a broad range of substances regardless of shape, transparency, or color. As the identity indicates, ultrasonic sensors measure distance with the aid of the usage of ultrasonic waves.

A diaphragm drive is an effective movement pump that makes use of an aggregate of reciprocation motion and both a flapper/ball valve to switch fluids. The pump is on occasion as a skin-like pump. These are self-pumping and good for viscous liquids.

A push-button or genuine button is an easy swap mechanism to manipulate some issue of a desktop or a process.

In the easiest terms, a light-emitting diode (LED) is a semiconductor that emits mild when an electric powered modern-day is exceeded thru it. Light is produced when the particles that raise the cutting-edge (known as holes and electrons) mix collectively inside the semiconductor material. Since mild is generated inside the strong semiconductor material, LEDs are described as solid-state devices.

The UI consists of four buttons and 7 LEDs. The buttons are as: power, Wi-Fi, spray, and fill/sense.

In the version a light-emitting diode (LED) is a semiconductor that emits light when it exceeds power. At the end of the particle, the semiconductor material contains a mixture of electrons and holes (holes and electrons). Then light is generated. LEDs are called solid state devices because they are soft to strong semiconductor materials. The UI comprises 4 buttons with 7 LEDs. On/Off Button, Wi-Fi, Spraying technique, and Charge/Detector.

## 4. RESULTS AND DISCUSSION

The code for this device used to be geared up the usage of a Finite State Machine (FSM). Figure 5 states the cyclic process of the device.

The design of the Sanitization surface is done by a spraying technique as a result of verification over the sensory technique done after Monitoring the process with the connection of sensing of spraying time monitoring at the surface. The process is though being a cyclic one Object-oriented code used to arrange the code, written in C++ (Arduino), with instructions for organization and readability. After being written in Arduino IDE; it is

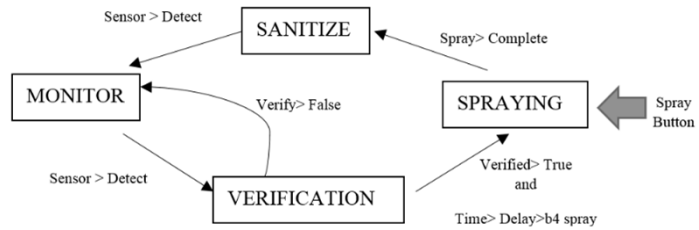

Figure 5: Cycle of Process

uploaded on the Arduino board for execution. It was identified six aspects of this device that would take this device to the next level with engineering as spray pattern, aiming spray, housing manufacturing, Wi-Fi configuration, level sensing, and power button.

With the support of the micro controller and pump assembly with sensors, it can automate the process of sanitizing door handlers whenever been used. If the distance is below 7 cm, the pump starts the relay for 100 ms, releases the liquid alcohol and detects the distance every 1000 ms. Hand sanitizers used in the test were isopropanol and chlorine. Hexidine gluconate in liquid form (0.3%) should also be used in gel hand sanitizers. The microcontroller holder with sensor and pump unit allows you to disinfect the door handle automatically after each use.

## 5. CONCLUSION

Outbreak of the COVID virus has modified the manner in which people interact with each other. High interaction areas such as pin pads, gasoline pumps, and door handles pose a hazard to the exposing of virus and generate problems for personnel to maintain. Hand sanitizers have been developed for use of cleaning of arms besides cleaning soap and water, gels comprise alcohol to kill germs existing on the skin. Sanitizer is low of price cheaply handy to use for cleaning of hands, convenient, portable, and handy to use and much less time-consuming. So, in this proposed design a hand sanitizer is connected to the door so that it can take care of and release the liquid automatically when the consumer touches the door handle. The device was designed in such a way that it can automatically sanitize the region between users, as a gadget created applies a mist of cleansing. It shortly vaporizes leaving a sanitized surface for the subsequent user.

## REFERENCES

- Arnab Das A., Barua A., Mohimin A., Abedin J., Khandaker M.U., Al-mugren K.S.,2021. Development of a Novel Design and Subsequent Fabrication of an Automated Touchless Hand Sanitizer Dispenser to Reduce the Spread of Contagious Diseases, MDPI, 10 April 2021
- Dyer D.L., Gerenratch K.B., Wadhams P.S., 1998. Testing a New Alcohol-Free Hand Sanitizer to Combat Infection, 68(2), pp. 239-251, First published: 01 August 1998, [https://doi.org/10.1016/S0001-2092\(06\)62517-9](https://doi.org/10.1016/S0001-2092(06)62517-9)
- Edozie E., Janat W., Kalyankolo Z., 2020. Design and Implementation of a Smart Hand Sanitizer Dispenser with Door Controller using ATMEGA328P. *International Journal of Engineering and Information System*,4(6), pp.14-18
- Gupta A., Kumar R., Nirjuli U.P, Pradesh A., 2020. Novel design of automatic sanitizer dispenser machine based on ultrasonic sensor. *Zeichen Journal India*, 6(8), pp. 228. ISSN No: 0932-4747
- Harshil Sathwara H., Vaghela P., Joshi S., 2021. AROGYAKAVACHAM—Automatic Hand Sanitizer Dispenser with Temperature Measurement. *Proceedings of the International e-Conference on Intelligent Systems and Signal Processing*. pp 785-796, 14 August 2021



- Hilburn, J., Hammond, B.S., Fendler, E.J. and Groziak, P.A., 2003. Use of alcohol hand sanitizer as an infection control strategy in an acute care facility. *American journal of infection control*, 31(2), pp.109-116.
- Jing J.L.J., Bose R.J.C., McCarthy J.R., Tharmalingam N., Madheswaran T., 2020. Hand Sanitizers: A Review on Formulation Aspects, Adverse Effects, and Regulations. *International Journal of Environmental Research and Public Health*, 2020
- Lee J et al., Design of Automatic Hand Sanitizer System Compatible with Various Containers, Accepted 20 July 2020, The Korean Society of Medical Informatics
- Lesmana, J., Halim, A. and Irawan, A.P., 2020, December. Design of automatic hand sanitizer with ultrasonic sensor. In *IOP Conference Series: Materials Science and Engineering* (Vol. 1007, No. 1, p. 012164). IOP Publishing.
- Livshits, B. and Chong, S., 2013. Towards fully automatic placement of security sanitizers and declassifiers. *Acm Sigplan Notices*, 48(1), pp.385-398. <https://doi.org/10.1145/2480359.2429115>
- Marcinga D.R., Sattar S.A., Jaykus L.A., Arbogas J.W., 2020. Improved Inactivation of Nonenveloped Enteric Viruses and Surrogates by a Novel Alcohol-Based Hand Sanitizer. *ASM Journals-Applied and Environmental Microbiology*, 74(6) 17 October 2020.
- Sandora, T.J., Taveras, E.M., Shih, M.C., Resnick, E.A., Lee, G.M., Ross-Degnan, D. and Goldmann, D.A., 2005. A randomized, controlled trial of a multifaceted intervention including alcohol-based hand sanitizer and hand-hygiene education to reduce illness transmission in the home. *Pediatrics*, 116(3), pp.587-594.
- Sitompul B.P., Saputra W., Gunawan I., 2021. Design and build of Automatic Hand Sanitizer using Arduino. STIKOM Tunas Bangsa Pematangsiantar, EDUWEST, March 2021
- Srihari M. M., 2020. Self-Activating Sanitizer with Battery Imposed System for Cleansing Hands. Institute of Electrical and Electronic Engineers, *International Conference on Inventive Research in Computing Applications (ICIRCA)*, 2020
- Villa C., Russo E., 'Hydrogels in Hand Sanitizers', MDPI, 2021
- Welearegai, G.B. and Hammer, C., 2017, July. Idea: Optimized automatic sanitizer placement. In *International Symposium on Engineering Secure Software and Systems* (pp. 87-96). Springer, Cham.

# Enhancing Air Quality and Controlling Indoor Air Pollution by Using Low-Cost Air Purification Strategy

H.M.R.G Hearth, Sondarangallage D.A. Sanjeewa\*

Department of Electrical & Electronics Technology, University of Vocational Technology, Sri Lanka

## ABSTRACT

*Air pollution is a major environmental concern these days, and it's more than just a fact; it's a painful fact that causes problems for humans, such as serious health problems. According to WHO data on indoor air pollution and health, indoor air pollution causes 3.8 million premature deaths each year, including stroke, chronic, ischemic heart disease, obstructive pulmonary disease and lung cancer. As a result, the majority of research has focused on various air purification methods. The most dangerous pollutants are PM 2.5 particles. The majority of these can be found both inside and outside of buildings. Because effective air filtration is an expensive process, the solution is to cut costs while maintaining efficiency. This paper discusses the current state of human air pollution problems, low-cost and effective air purification methods like HEPA filters, activated carbon, and ultraviolet light, and how they developed this system. In addition to that, the benefits of air purification in improving indoor air quality are discussed.*

**Keywords:** Indoor Air Pollution, Enhancing Indoor Air Quality, Air Quality Index, Air Purification System and HEPA.

## 1. INTRODUCTION

Air pollution has recently risen to the top of the list of factors contributing to death, and it is fair to say that humankind has been unsettled by its very existence. When it comes to air pollutants, the deadliest ones are those that have a diameter smaller than 2.5 microns and emit nitrogen oxides. The human body is designed to allow particles to enter when we breathe. Still, the problem arises when dealing with PM 2.5 particles (particulate matter), which are so minute that our body cannot catch them. For this reason, many respiratory disorders have risen recently. According to the WHO, it can be considered a very significant increase in respiratory diseases. Nearly nine out of ten people (92% of the global population) were living in areas where air quality was below WHO standards in 2014. (WHO, 2018).

A major public health issue that affects people in developed and developing countries alike is indoor and outdoor air pollution. Although there are several air contaminants, the most significant are PM<sub>2.5</sub> (particulate matter 2.5), CO (carbon monoxide), O<sub>3</sub> (ozone), NO<sub>x</sub> (nitrogen oxides), SO<sub>2</sub> (Sulfur oxides), and Pb (lead), all of which are prevalent in ambient atmosphere. The above pollutants that meet specific criteria can be found indoors as well as outdoor. Specifically, indoor pollutants such as PM, CO, SO<sub>2</sub>, NO<sub>2</sub>, cigarette smoke, formaldehyde, and polycyclic organic matter can be present indoor (Bruce, Perez-Padilla and Albalak, 2002) (Senevirathne, 2003)

Moreover, in Sri Lankan domestic houses, most of the time, windows are closed and rarely open. That is common in all developing countries. They are causing major differences in indoor and outdoor air quality. Because cooking is primarily done with firewood or charcoal, which is more suitable as an outdoor domestic activity, another component that affects indoor air quality is changing lifestyles, working environments, and home maintenance. Most people in Sri Lanka spend more time indoors. During the cooking process, the children also spend a lot of time with their mother or parents. The impact on children is highlighted by the fact that their airways are smaller and more responsive to inflammation. Breathe faster since their lungs aren't fully developed. Children need more air per body mass to breathe than adults. That is why an indoor air purifier has become so important, and now it

---

\* Corresponding Author: E-mail- [sdasanjeewa@uovt.ac.lk](mailto:sdasanjeewa@uovt.ac.lk)

is considered a necessity. Although air filtration devices are available on the open market, many of the benefits are insignificant when compared to the cost.

An air purifier is a device that improves the quality of indoor air by removing particles and allergens. Allergy and asthma sufferers benefit from these products, which are also touted as helping to reduce or eliminate exposure to secondhand smoke. Air handling units (AHUs) and HVAC units (heating, ventilation, and air conditioning) in the medical, industrial, and commercial sectors all use commercial air purifiers. It is common in industry to use air purifiers before a procedure to remove impurities like CO<sub>2</sub>. Indoor purifiers with HEPA are available on the market for the finest results in smoke and odor removal in varied locations. It combines efficiency and dependability with a trendy retro style. However, their market value is close to the \$500 price. However, this development is less expensive than the commercial system. In addition to the innovative technology, a low-power blower fan is used, and the outside cover has a simple column design. Furthermore, the Arduino microcontroller, DSM 501 dust sensor, and DHT 11 sensor are all available for around \$15 on the open market. The purification structure was more reliable and effective for low-cost development. Because the blower fan consumes 20W of power, the power consumption is low. In addition, there are no chemicals in the system, and it does not require maintenance.

## 2. LITERATURE REVIEW

Children are also influenced because they spend more time in the kitchen with their mothers. Pneumonia, bronchitis, asthma, and other respiratory disorders are very common among these two groups of people who cook with firewood or other types of biomasses. Indoor air pollution from wood-burning stoves is a severe health hazard that affects people's health. According to the World Health Organization, 4300 people died in Sri Lanka in 2004 as a result of indoor air pollution (WHO, 2009). Wood smoke contains extremely high quantities of air pollutants such as carbon monoxide (CO), fine particles, and polyaromatic hydrocarbons like benzopyrene, all of which are proven carcinogens. PM<sub>2.5</sub> concentrations as high as 122.3 g/m<sup>3</sup> have been found in houses using firewood, compared to 47.3 g/m<sup>3</sup> in households utilizing cleaner fuels (Nandasena, Wickremasinghe and Sathiakumar, 2011).

Moreover, mosquito coils and incense sticks are burned commonly inside residences. Mosquito coils are utilized by 2 billion individuals around the world each year, with approximate usage of 12 billion coils. Pyrethroids, coal dust/coconut husk, binders, and resins are all found in a conventional mosquito coil. (Liu *et al.*, 2003) According to the study, burning one mosquito coil produces the same amount of PM<sub>2.5</sub> as 100 °C and releases the same amount of formaldehyde as 50 °C. Furthermore, the quantities of polyaromatic hydrocarbons are high enough to harm people's health. Long-term exposure to these chemicals, even at minimal amounts, may raise cancer risk.

Microplastics, the latest air pollutant, have been a source of concern in recent years, with microplastics found in both outdoor and interior air. Although the long-term health effects of microplastics have yet to be determined, some of the tiniest microplastics with diameters of less than 2.5 micrometres (PM<sub>2.5</sub>) have been identified as seen in the bloodstream. These factors can contribute to arterial hardening, which can lead to heart disease.

Biological pollutants in the house also contribute to indoor air pollution. Biological pollutants are bacteria, mould, mildew, viruses, cockroaches and animal dander. And also, House dust mites are one of the most important bioactive allergens, grow in moist, warm conditions. Hypersensitivity pneumonitis, some cases of asthma, and allergic rhinitis are all caused by biological pollutants (US EPA, OAR, ORIA, IED, 2018). There are several procedures recommended in order to decrease exposure to biological pollutants such as dust mites, domestic pets, and cockroaches. Nonbiological sources include wood smoke, tobacco smoke, and volatile organic compounds (VOCs). New and effective measures, such as the development of indoor air purifiers, have emerged as a result of a greater understanding of indoor pollutants.

Analyzing further, the mechanical air purifiers have a smaller market share. Primary and intermediate filtration is still commonly utilized in the pre-stage filtration of highly efficient filters (Rice *et al.*,

2018). The impact of mechanical air filters on indoor air pollution was studied by (Vijayan et al., 2015). Contaminated air can pass through mechanical air filters because of their mesh structure. The size of the mesh pore is critical in determining the efficiency of mechanical filters. Due to the mesh pore size, pollutant particles larger than the mesh pore size cannot pass through. PM particles cannot be removed from indoor air by these air filters. Several large particles can be filtered through a single filter.



Modern air purifiers almost always use High Efficiency Particulate Air (HEPA) filters to filter out PM. Particulate matter smaller than 0.3 microns is removed from contaminated air with a flow rate of 150-400 CFM (cubic feet per minute), depending on the obstruction of their pores. Their effectiveness is 99.97%. Using the Brownian motion theory, HEPA filters collect dust using three different techniques: impact, interception, and diffusion.(Roy *et al.*, 2018).

Another study of air filtering technology is active carbon (Chambre, 2014). The gaseous pollutants in the air are cleaned out using activated carbon. According to (Chambre, 2014), there are two types of activated carbon: granular and bound. It has a high degree of porosity and a wide surface area for pollutant interaction. This allows it to have excellent adsorption properties. The principle guiding activated carbon's operation is based on the concept of adsorption.

This experiment was used to evaluate the formaldehyde purification performance of two air purifiers. The photocatalytic layer was also determined to be the purifier's most important component. The photocatalyst, carrier, and catalyst immobilization techniques are the most important aspects impacting the purifier's performance. Furthermore, the purifier's construction has an impact on its purification efficacy. The purifier structure should be designed with a suitable ratio of the radiation field, concentration field, and flow field in consideration (Deng and Zhang, 2018). Certain research has linked the development of indoor air purification technologies to the positive impact of cardiorespiratory health. (Allen *et al.*, 2011) develop the portable air filters by doing experiments by randomized crossover intervention study those who measured the effect on vascular function. Improved endothelial function and lower levels of inflammatory biomarkers were found in the study's findings. Claudia Sulser (Sulser *et al.*, 2008) studied the asthma outcomes by using the air purifying method of HEPA filters. Their study design was randomized controlled at home. They found a reduction in nocturnal symptoms by using HEPA filtering technology at the indoor air purification system.

## 2. METHODOLOGY

Table 1: Proposed Air filters and Their Feature

Filtering Method	Features	Appearance
<b>Mechanical Filter</b>	Massive volumes of dust particles, fabric fibers, and animal fibers are retained during mechanical filter separation. However, the drawback of this sort of filter is that it obstructs airflow.	 Source: (tofee.com.cn, n.d.,2021)
<b>HEPA Filter</b>	The air filter is responsible for effectively filtering even the most particle air. Its purpose is to capture dust particles from the atmosphere. Filters have a 99.97% effectiveness in eliminating particulate matter smaller than 0.3 microns	 Source: (Paul, 2020)
<b>Carbon Filter</b>	This is used to lower atmospheric concentrations of carbon dioxide and other polluting gases. The more micro pores a filter has, the more gas and odor it can arrest, and the longer time it can function before needing to be replaced.	 Source: (Sarah, 2014)

**UV Filter**

It kills bacteria in the air by using UV rays to eradicate fungus and other airborne ailments. An air purifier's UV mode is intended to kill germs in the air. The most effective way to clean the air is to use UV and/or HEPA filters together.

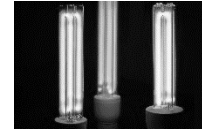

Source: (Gagne, 2021)

In this proposed method, first, the filtering structure with the highly effective low-cost method is created. After the literature review, the researchers observed that both biological and non-biological pollutants contribute to indoor air pollution. Table 1 shows an overview of the proposed air filters and their features.

Following filters are used in the filtering process to ensure that the air is cleaned properly, as shown in Figure 1 block diagram below.

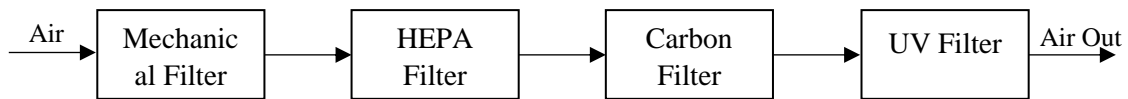

Figure 1: Block Diagram of Filtering Structure

Figure 2 shows a sensor detection hardware architecture that may be used to view all of the implementation details. The air pollution detection kit is created using the Arduino nano.

The air purification system is activated in two steps after it has been started. The first phase includes gathering data from DSM501 dust sensors connected to an Arduino board and monitoring the information on a display.

The DSM501 sensor detects pollution levels in the atmosphere. PM2.5 and PM10 are measured by the pollutant. The system is active depending on the quality of the air pollutants. It varies depending on the value of the Air Quality Index (AQI).

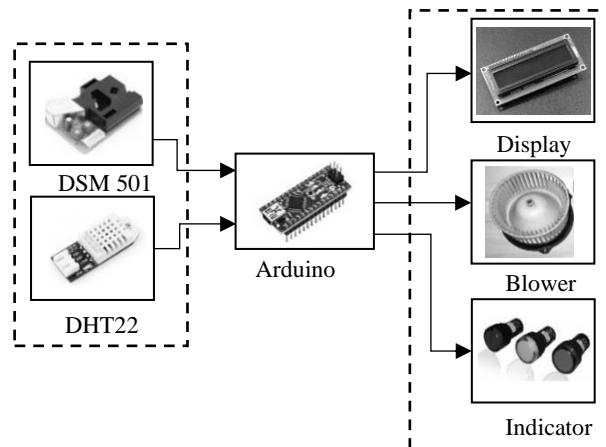

Figure 2: Sensor Detection Hardware Architecture



Figure 3: Final Design of the Purification System

The air purification system and the blower will not operate if the AQI value is less than 50. The air purification system is activated once it reaches an unfavorable level. This saves energy and allows the indoor air system to run sustainability. Table 2 (Katara *et al.*, 2017) shows the air quality index breakpoints.

Table 2: Air Quality Index

AQI category	AQI	PM <sub>2.5</sub> (24-h) (µg/m <sup>3</sup> )	PM <sub>10</sub> (24-h) (µg/m <sup>3</sup> )
Good	0–50	0.0–12.0	0–54
Moderate	51–100	12.1–35.4	55–154
Unhealthy for sensitive groups	101–150	35.5–55.4	155–254
Unhealthy	151–200	55.5–150.4	255–354
Very unhealthy	201–300	150.5–250.4	355–424
Hazardous	301–400	250.5+	425+

The hardware architecture is built up first, followed by the connections. Based on dust sensor readings, an Arduino program is written to determine air quality. The DSM501 dust sensor, for example, detects PM2.5 in the air. On the COM screen of Arduino, the DSM501 sensor's output is displayed as an analog value. The Arduino board is connected to the DSM501 sensor. The AQI value of the display is monitored by Arduino. Also, make a note of the hazard lamp.

If the air quality index reaches a hazardous level, the purifier will turn on. This purifier has a dust sensor that detects air pollutants. There are also sensors that detect things like temperature and humidity. The Arduino used in this sensor has been programmed. Polluted air is fed into the sensor, and the sensor's output is a reading of the concentration of pollutants in the air. When it detects air, it shows the area's air quality index and illuminates an indication indicating high pollution and the need to start the system if that value is harmful for inhalation. The whole thing is a mashup of different air quality sensors and filters.

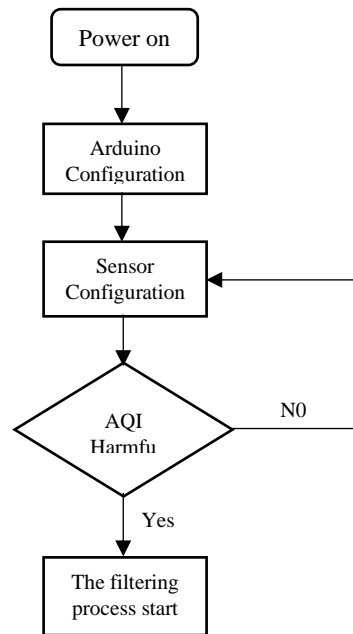

Figure 4: Purification System Process Flow Diagram

**2.1. Components**

For this project, the DSM 501 dust sensor is an excellent and cost-effective option. The DSM 501 is a sensor module that can detect dust levels. The dust sensor detects fine particles as small as 1µm and counts the number of floating particles in a room up to 30m<sup>3</sup>. The sensor creates a forced influx of sampling air and analyzes particle dispersion of reflected light. The dust sensor module operation supply voltage is 5.5V DC. The maximum current consumption is 90mA. Operation temperature range is -20C to 80C.

**2.2. Temperature and Rh Sensor**

The digital signal from the DHT22 is calibrated. In order to ensure its dependability and stability, it makes use of proprietary digital signal collection technique and humidity sensor technology. It has an 8-bit CPU on a single chip that's connected to various sensors. In this model, every sensor has its temperature rectified and calibrated in a precision chamber, and the calibration coefficient is stored in OTP memory as a type of software as a program. Upon detection, the sensor will pull the coefficient from its internal memory and display it. Because of its small size, low power consumption, and high transmission distance (20m), the DHT22 is well-suited for use in a variety of severe environments. Four pins per row in a single-row box make connecting a simple. (Liu, 2020)

### **2.3. Arduino Nano**

The ATmega328 microcontroller is used to power the LCD display. There are 14 digital pins, 8 analog pins, two reset pins, and six power pins on the Arduino Nano. Because it accepts analog signals as input, it is ideal for our purifier because all of the inputs are analog signals. The Arduino IDE is used to program it. It has a 5V operational voltage. However, the input voltage can be anywhere between 7 and 12V. The maximum current rating of the Arduino Nano is 40mA, so the load connected to its pins should not drain more than that.

### **2.4. LCD Display**

This LCD Keypad shield for Arduino and various Arduino versions is quite popular. A 2x16 LCD panel and six momentary pushbuttons are included. The LCD is controlled by pins 4, 5, 6, 7, 8, 9, and 10. To read the five pushbuttons, only one Analog Pin 0 is used. The LCD shield allows you to change the contrast and turn on/off the backlight.

### **2.5. Indicator**

LED is used for the indicator that is low cost-effective use. LED bulks are being used to indicate the AQI breakpoints. The LEDs that were used were red and green.

## **3. RESULTS**

Indoor environment AQI PM10 level was increased 3 times in three days, as per the project's objectives. The air quality measurement equipment occupies a 20 x 25 ft. space. There are no open windows in the kitchen. In the room, the purification system has been installed. Figure 4 shows at 12-02 p.m., about 04 individuals were working in the rooms, and the temperature was normal. The average AQI value in this area is 34. Figure 5 shows 07-08 pm time the 04 working people in the room and during this time, they burned coils to repel mosquitoes and turned on the gas burner for cooking. The average AQI value at the time was 53. The air filtration system was turned on because the AQI value had increased to a point where it was harming the average air value. The AQI value was found to be decreasing over time. During 10 pm - 12 am time, and the average AQI value is 26. That time the no work in the room and only burned to repel mosquitos' coil. When it comes to daytime work and when there is a lot of activity and human activity, this system is most useful. It can help maintain healthy indoor air quality.

## **4. CONCLUSION**

This project aims to study and develop a low-cost indoor air purifying system. People face a serious respiratory problem with air quality today. Inhaling unhealthy air has a negative impact on people's health and causes a variety of ailments. Indoor pollution is currently on the rise due to a variety of factors, including biological pollutants such as bacteria, mold, mildew, viruses, and animal waste. In addition, mosquito coils, wood, and microplastics are all burned and released into the air. As a result, For the purpose of reducing the amount of pollution coming from various sources and protecting people and the indoor environment from potentially harmful gasses, this air pollution purification system was created.

Incorporating Arduino technology into the purification system enables the user to estimate the level of pollution in their entire indoor space, and the purification system automatically kicks in when the reading reaches a dangerous level. The Arduino microcontroller and purification structure were more reliable and effective for low-cost development. To absorb PM 2.5 particles, HEPA filters were developed, which have a multi-layered structure of glass fibers. They do guarantee a 99.97% efficiency rate. Activated carbon is a traditional method of purification that has few to no disadvantages. UV light proves to be an effective strategy for combating bacterial contaminants, as long as the wavelength of light employed is not harmful to humans. This paper compiles a list of some of the air purification systems that are both cost effective and efficient.

People with respiratory diseases can gain a lot of benefits from this air purifying system, which also includes AQI monitoring. The system had the following features: indoor air quality index based on real-time monitoring, daily air quality forecasts, air quality dips associated with health risks, and specific reporting for indoor air quality measures.

## REFERENCES

- Allen, R. W. *et al.* (2011) ‘An air filter intervention study of endothelial function among healthy adults in a woodsmoke-impacted community’, *American Journal of Respiratory and Critical Care Medicine*, 183(9), pp. 1222–1230. doi: 10.1164/rccm.201010-1572OC.
- Bruce, N., Perez-Padilla, R. and Albalak, R. (2002) ‘The health effects of indoor air pollution exposure in developing countries’, *Geneva: World Health Organization, Report WHO/SDE/OEH/02.05*, pp. 1–40.
- Chambre, A. (2014) ‘Effects of Carbon Filtration Type on Filter Efficiency and Efficacy : Granular Loose-Fill vs Bonded Filters’, *Air science*, 1(March), pp. 1–5.
- Deng, Z. and Zhang, X. (2018) ‘Performance test and structural analysis of indoor air purifier’, *Chemical Engineering Transactions*, 71, pp. 817–822. doi: 10.3303/CET1871137.
- ISO-Aire Air Purifiers. (n.d.). *What is a HEPA Filter - How HEPA Filtration Works*. [online] Available at: <https://www.iso-aire.com/blog/what-is-a-hepa-filter-and-why-is-it-effective-against-covid-19> [Accessed 13 Sep. 2021].
- Katara, N. *et al.* (2017) ‘Interference Study of Pollutants Released from Various Industrial Areas in a Region: A Case Study’, *American Journal of Environmental Protection, Vol. 5, 2017, Pages 82-88*, 5(3), doi: 10.12691/env-5-3-4.]
- Liu, W. *et al.* (2003) ‘Mosquito coil emissions and health implications’, *Environmental Health Perspectives*, 111(12), pp. 1454–1460. doi: 10.1289/ehp.6286.
- Nandasena, S., Wickremasinghe, A.R. and Sathiakumar, N. (2011). Biomass fuel use for cooking in Sri Lanka: Analysis of data from national demographic health surveys. *American Journal of Industrial Medicine*, 55(12), pp.1122–1128.
- Rice, J. L. *et al.* (2018) ‘The feasibility of an air purifier and secondhand smoke education intervention in homes of inner city pregnant women and infants living with a smoker’, *Environmental Research*, 160(September), pp. 524–530. doi: 10.1016/j.envres.2017.10.020.
- Roy, A. *et al.* (2018) ‘A review of general and modern methods of air purification’, *Journal of Thermal Engineering*, 5(2), pp. 22–28. doi: 10.18186/THERMAL.529054.
- Sarah (2018). *Activated Carbon Filters: What They Are & How They Work*. [online] Allergy & Air. Available at: <https://learn.allergyandair.com/activated-carbon-filters/>.
- Senevirathne, S. (2003) ‘Air pollution : a case study of College of Community Physicians of Sri Lanka’, *Journal of College of Community Physicians of Sri Lanka*, 8.
- Sulser, C. *et al.* (2008) ‘Can the use of HEPA cleaners in homes of asthmatic children and adolescents sensitized to cat and dog allergens decrease bronchial hyperresponsiveness and allergen contents in solid dust?’, *International Archives of Allergy and Immunology*, 148(1), pp. 23–30. doi: 10.1159/000151502.
- US EPA, OAR, ORIA, IED (2018). *Biological Pollutants’ Impact on Indoor Air Quality | US EPA*. [online] US EPA. Available at: <https://www.epa.gov/indoor-air-quality-iaq/biological-pollutants-impact-indoor-air-quality>.
- Vijayan, V., Paramesh, H., Salvi, S. and Dalal, A.K. (2015). Enhancing indoor air quality –The air



filter advantage. *Lung India*, [online] 32(5), p.473. Available at: [https:// www.ncbi.nlm.nih.gov /pmc /articles/ PMC4587002](https://www.ncbi.nlm.nih.gov/pmc/articles/PMC4587002)

WHO (2018). *Ambient (outdoor) air quality and health*. [online] Who.int. Available at: [https://www.who.int/news-room/fact-sheets/detail/ambient-\(outdoor\)-air-quality-and-health](https://www.who.int/news-room/fact-sheets/detail/ambient-(outdoor)-air-quality-and-health)

# IoT Based Smart Home Control and Monitoring System

H.S.N. Kumara, A.J.T. Sandaruwan, D.M.D.S. Bandara, Madhavi Perera\*

Department of Building Services Technology, University of Vocational Technology, Sri Lanka

## ABSTRACT

*In the present context with the industrialization and busy lifestyle of the people the need to automate and remotely control certain routine chores has become very common. Since smartphones are becoming an integral part of human life they are also used as a tool to automate and control these routine chores. Therefore, people prefer to control the electrical appliances in the house using a smartphone and to quickly detect and correct any emergency such as a gas leak in the house. The purpose of this project is to establish an automated system to control all the essential tasks that are required for a Sri Lankan household. This is done using wireless technology these systems can be controlled from anywhere, even away from home. This system was developed because most of the devices and systems available today in the market are expensive and not developed to fulfill all requirements of Sri Lankan homes. The system will save the time of people, money as well as labor as they can easily meet the needs of their homes through automation.*

**Keywords:** Internet of things, Passive infrared ray, Smart Home, Voice command

## 1. INTRODUCTION

Today, smartphones are becoming an integral part of human life. Since the lifestyle of people has also become busier, they prefer to automatically control the routine chores in their houses and also remotely monitor them. It is easier to control the electrical appliances in the house using a smartphone while improving the energy efficiency and ensuring the security of the system and energy-saving manner. There are many technologies to develop such smart home systems. In this project, the IoT concept is used with a Wi-Fi connection and an android app (smartphone). It is an absolute home automation package for Sri Lankans with home appliances controlling including garden irrigation and system also water tank water level controlling system using which is a unique and essential requirement for Sri Lankan middle-class homes. The system can be controlled by touch commands given to the smartphone and also through voice commands.

## 2. OBJECTIVES

The main objective of this project is to design a smart home system suitable for the automation and remote-control requirements of Sri Lankan houses. In order to do so, the shortcomings of the smart home systems available in the Sri Lankan market have to be identified, and hence it is another objective of the project. Integrating the additional system features such as voice control, secure remote access and the facility to add and remove features as per the requirement of the customer is the other objective.

## 3. LITERATURE REVIEW

It can be observed that the advancement of technology has transformed how we operate and control the appliances in our homes. When electric appliances were added with advanced features in the 1990s, the smart control system was initiated however the smart home concept was popularized with the wide use of the internet.

“The smart home concept started with the invention of remote controls, unveiled by Nikola Tesla in 1898. 1901 – 1920 was the era when home appliances were invented. In 1966 the first home automation system ECHO IV was invented. In 1991 a concept called “gerontechnology” was introduced which combines gerontology and technology to make the lives of senior citizens easier.”

---

\* Corresponding Author: E-mail - [madhavigdy@gmail.com](mailto:madhavigdy@gmail.com)

(BCC Research, 2018) Today the smart home systems focus more on security features and increasing the sustainability.

Wagh & Wasnik (2014) observed that home automation can change the way people live. They further stated that some of these home automation systems target those seeking luxury and sophisticated home automation platforms; others target those with special needs like the elderly and the disabled. There are many Home Automation technologies are available but there are no standard practices among designers, installers and contractors to realize the systems which have lowered the quality.

### 3. METHODOLOGY

As the first step of the methodology, the drawbacks of existing smart home systems and the requirement that needed to be added to the systems were identified. The main drawbacks identified were security issues, difficulty in installing and maintaining and also the higher prices which are not affordable for middle-class homeowners. Also, it was noted that current systems do not cater to some of the automation requirements in Sri Lankan homes such as pumping water for overhead tanks.

This system is developed as four separate subsystems with 4 Node MCU controllers. The reasons for selecting such a modular architecture are to ensure better security (compared to the integrated systems), easiness in customizing the automation systems as per consumer need and easiness in repairing and maintaining.

The system can be applied to existing wired homes and also implement as a separate system as shown in the figure 1 and figure 2.

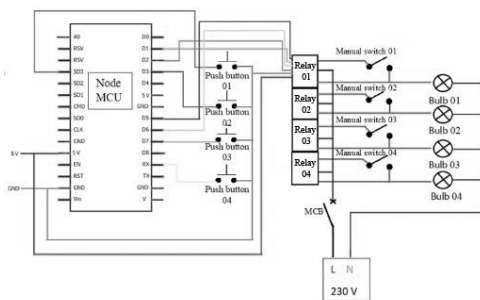

Figure 4: Circuit Diagram for Unit Installation to Existing Systems

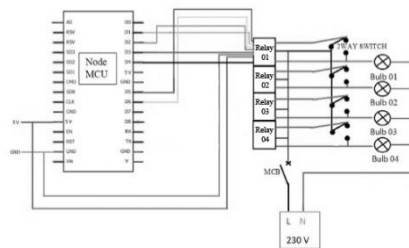

Figure 3: Circuit Diagram for Installing Unit as New Systems

### 4. IMPLEMENTATION

The system implementation is carried out in two sub-divisions, software and hardware implementation. The hardware implementation is to develop the main controller, sensor network and smart home arrangement. The software implementation is carried out for programming of the Node microcontroller through Arduino IDE and configuring the Blynk app and google assistant in the smartphone. The communication between the smartphone and the Node MCU is done in wireless mode and implemented over the internet.

The basic hardware required for the system are Node MCU – 32-bit ESP8266 development board with Wi-Fi SoC, relay module, IR sensor, gas leakage checking sensor (MQ-2), humidity & temperature sensor (DHT11) ultrasonic sensor (HC-SR04), soil moisture sensor, micro submersible mini water pump, DS18B20 temperature sensor and HC-SR501 passive infrared (PIR) motion sensor. The proposed system is implemented using Node MCU to overcome the drawbacks identified above. The sensors are connected to the Node MCU board and the status of the system can be observed from the smartphone. The Blynk app provides the web interface needed to view and remotely control all the processes that take place. The system is updated in every second therefore the real time data would

be indicated. All devices also integrated with voice control, making it easy for people with disabilities to control the system.

Blynk software configuration only changes from system to system depending on the number of the sensors being added and the number of controllable devices and device types. After entering the code needed to control those different devices into the Node MCU, the system connects to the smartphone via the WiFi network.

The Blynk software creates the necessary access to this connection between hardware and software.

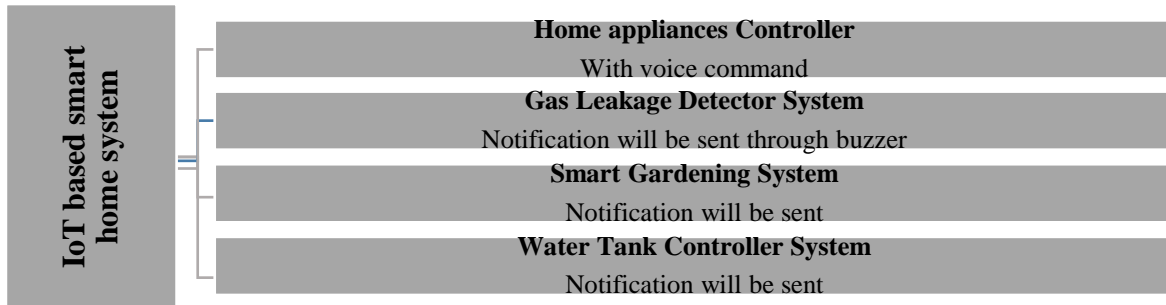

Figure 5: System Architecture

As mentioned above the system has a modular architecture which is illustrated in figure 3. The main advantage of the modular architecture is the low cost. According to the customer requirement the system units will be developed with relevant modules. The remote home appliances controller will be supplied freely with any other combination of modules since home appliances controller is in built. Therefore, this system is low cost for consumers. From the developer's side also it will be low cost due to the reason of separate unit equipment cost is low. When the system is expanded for whole house, additional cost would be for additional relays, therefore this entire system is low cost when comparing to the existing system in the market.

Sub system 1 is for the control of home appliances using a smartphone, using Google Assistant and also to control home appliances using manual switches in the absence of WiFi. The circuit is very simple; controller GPIO pins D1, D2, D5 & D6 were used to control the 4 relays and the GPIO pins SD3, D3, D7 & RX were connected with switches to control the 4 relays manually.

For multiple room implementation the same circuit will be repeated at for each room. There is no limitation for the number of Node MCUs that can be connected.

All Node MCUs will be connected to the Blynk server using the same authentication token. Therefore every NodeMCU can be controlled independently using Blynk App. Multiple smartphones also can be used to control the appliances with Blynk App by login to the same user account from all devices. The system can be controlled and the real-time status of the relays can be monitored from anywhere in the world with the Blynk App. If the WiFi is not available, the relays can be controlled from the pushbuttons.

Sub system 2 is for identification of a gas leakage at the home through a smartphone and set up a system to take action against it. If a leakage is detected the siren is activated to inform the residents and a notification will also be sent to the smart phone.

Sub system 3 is designed for a system to monitor the water capacity of the water tank in the house using a smart phone so that in case of water shortage the water pump automatically activated from the system.

Sub system 4 is developed for automatic irrigation in the garden using a smart phone.

## 5. COST CALCULATION

The smart home system introduced can be installed in an existing house or a new house under construction. This system is designed to target middle class customers and cost of the system may vary according to the requirement and size of the house. There we have, as a case study, estimated the cost of installing the system for a house of the type shown figure 4 and the estimated cost is given in the table 1.



Figure 4: Plan of Sample House Model

Table 1: Cost Estimation

Item location	installation	Item	Quantity	Retail price (Rs.)	Total cost (Rs.)
<b>Veranda</b>		ESP 12E WIFI Node MCU board	1	550.00	1100.00
		4-way relay module	1	350.00	
		Bread board	1	200.00	
<b>Living room</b>		ESP 12E WIFI Node MCU board	1	550.00	1100.00
		4-way relay module	1	350.00	
		Bread board	1	200.00	
<b>Bedroom</b>		ESP 12E WIFI Node MCU board	1	550.00	1100.00
		4-way relay module	1	350.00	
		Bread board	1	200.00	
<b>Dining &amp; pantry</b>		ESP 12E WIFI Node MCU board	1	550.00	1100.00
		4-way relay module	1	350.00	
		Bread board	1	200.00	
<b>kitchen</b>		ESP 12E WIFI Node MCU board	1	550.00	1100.00
		4-way relay module	1	350.00	
		Bread board	1	200.00	
<b>Garden &amp; flower tap</b>		ESP 12E WIFI Node MCU board	1	550.00	1520.00
		2-way relay module	1	190.00	
		Bread board	1	200.00	
		Moisture content sense	2	290.00	
<b>Gate external light</b>		ESP 12E WIFI Node MCU board	1	550.00	1100.00
		4-way relay module	1	350.00	
		Bread board	1	200.00	
<b>Total Cost</b>					<b>8120.00</b>

## 6. RESULTS

The final prototypes developed for the 4 sub-systems are shown in Figure 5 below, respectively. The advantages of the developed system can be listed as follows. Ability to achieve home automation function with minimum cost.

- Ability to remotely monitor the status of the controlled functions in real time through smartphone
- The system operates using Wi-Fi technology and has the ability to enable / disable it from remotely.
- Ability to manually operate the system even when the system is connected through internet /wireless technology.
- The system is designed to be simple and user friendly and can be operated by voice command
- The system cannot be accessed by anybody have the authentication credentials.

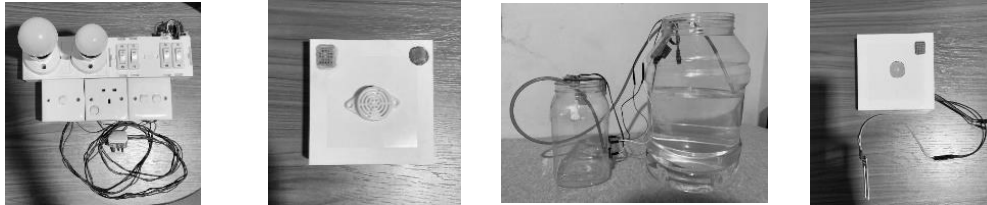

Figure 5: The Prototypes Developed for 4 Sub-systems

## 7. CONCLUSION

The paper has discussed the development of an IOT based home automation that can be controlled over the Wi-Fi through android app from any smart phone. The system implementation is explained in detail. The modular architecture of the system has enabled the system to be cost effective and customizable. The objectives of the project have been achieved through developing a system that addresses the issues of the prevailing smart home systems, This system has been developed specially concerning the requirement of middle class Sri Lankan home and it can be installed both for a new construction or for an existing home. Voice control and the ability to control the system remotely and securely are the main benefits of the system and when the cost of the system was compared with other systems in the market it was found that this system was cost effective than the others. Therefore this system can be recommended for the apartment buildings and other middle-class families which needs home automation with low cost.

## REFERENCES

- Ashraf I et al. (2020) Home automation using general purpose household electric appliances with Raspberry Pi and commercial smartphone. *PLOS ONE*.
- BCC Research (2018) *Smart Home Technologies: Global Markets to 2022*, s.l.: s.n.
- Wagh V and Wasnik P. M (2014) Different Technologies Used in Home Automation - A Review and Comparison. *International Journal of Engineering Research & Technology (IJERT)*, 3(2), pp. 130-135.

# IoT Based Tile Sorting Machine Using Image Processing

Viraj Narampanawa<sup>\*1</sup>, P.D.M Tharaka<sup>2</sup>, H.M.E.C Herath<sup>3</sup>, Dilshan Ganegoda<sup>4</sup>

<sup>1</sup>Green Leaf Threshing Plant, Ceylon Tobacco Company PLC, Kandy, Sri Lanka.

<sup>2</sup>Maintenance Department, Elegant Knitting International Pvt Ltd, Sri Lanka.

<sup>3</sup>Prime Tele Service Pvt Ltd, Sri Lanka.

<sup>4</sup>Department of Electrical and Electronics Technology, University of Vocational Technology, Sri Lanka

## ABSTRACT

*There's a wide utilization of items in our day-to-day life, and fabricating and dealing with of these products are drained numerous huge scales and small-scale businesses. Re-arranging them in to keep track is a quality consistency issue. These days the most trouble that's confronted after the generation is to sort and categorize their items concurring to their quality. In the majority of large industries, this process is done manually. The need of this type of machine is in the industries to help in sorting the products according to their height, size, color, shape, etc. Today industrial field requires demand for automation. Due to automation, human efforts are decreasing day by day since the last decade. At present industrial machines fabricated to detect color and sort items through image processing are widely used. This mechanism can be used to sort out the ceramic tiles and allocate them to specific places in a warehouse. In this research, designing and implementing an efficient IOT based color sorting using PC, Logitech c270 HD camera, Arduino mega2560, ESP32, drivers, motors and many more sensors and actuators.*

**Keywords:** HD, IOT, PC, PLC.

## 1. INTRODUCTION

There are various ways the generation chain of ceramic tiles can go off-base. Each disappointment straightforwardly reflects on the ultimate ceramic tile. The ultimate generation stage is the sorting of ceramic tiles. The reason of this stage is to dismiss flawed parts such as physical abandons and color shading. In most cases, the final stage of sorting tiles in classes of quality is based on human discernment capability. Human assets as controllers in this stage are exceptionally untrustworthy. The outlined programmed framework completely replaces the human assets and in collaboration, with suitable calculations, it can be more precise and proficient compared to people. The incredibly larger part of ceramic tile` issues are surface surrenders, such as splits, crazing, dry spots, pinholes, etc. (Boukouvalas et al., 1998) Therefore, surface inspection is one of the most important quality control tasks to be automated. Today digital image processing is used to extract various features from images. One of the most important operations on the digital image is to identify and classify various kinds of defects for classification. Therefore, automating the inspection stage of the product quality and classification them leads to the use of machine vision and image processing systems (Ahmadyfard et al., 2009).

Amid this entire extend we are attempting to completely computerize the method of sorting tiles and this can be contributing the tile sorting within the stockroom without any human review and it's doing the sorting handle of diverse kinds of tiles such as Glaze tile, Mat tile, and pattern tiles. And it's sorted to differently as its type of sort. This extend is most reasonable for tile sorting prepare in where house.

This is a fully automated machine associated with the electronics parts such as stepper motors. Stepper motors are used to rotate the conveyor to position and sort different tiles such as Glaze, Mate, or Pattern. Pneumatic actuators are working as a pusher. The pusher is pushing the tile towards the sorting conveyor from the main conveyor. There are auto driven conveyors and conveyers are operated integrating with the signals coming through the photocell sensors and materials associated with the smart device of IOT Arduino.

---

\* Corresponding Author: E-mail - [harshana\\_narampanawa@yahoo.com](mailto:harshana_narampanawa@yahoo.com)

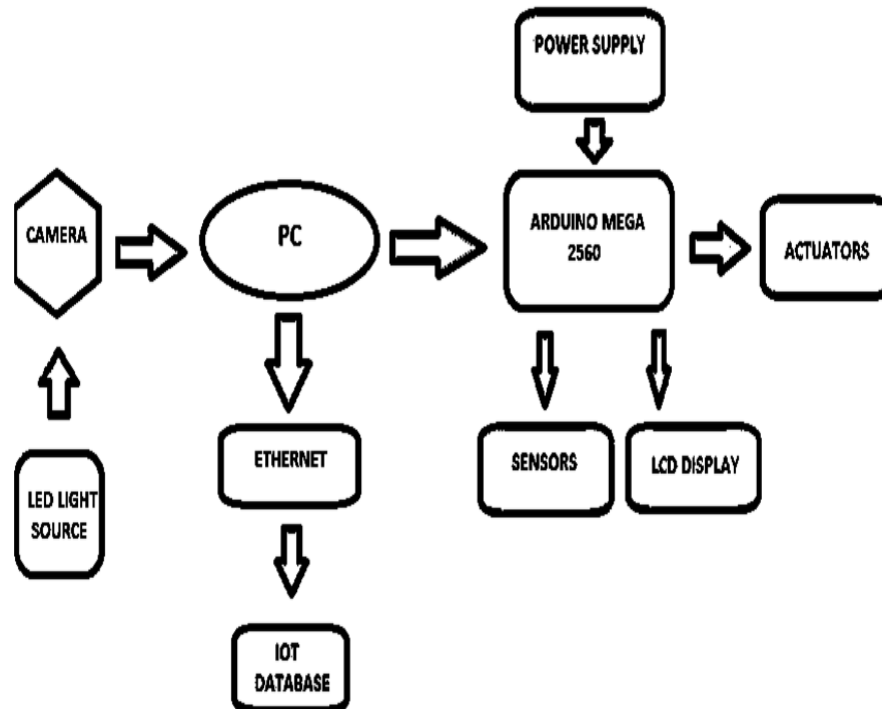

Figure 1: Block Diagram of the System Overview

The rest of the paper is organized as follows. Section 2 shows the methodology of the system. In section 3, results, section 4 results, discussion and conclusion of the paper.

## 2. METHODOLOGY

At the first stage, identified the ceramic tile using our computer vision with the help of our camera after successfully trained model on related with each tile category.

The researchers expect to do that identification and classification process with using open CV, tensor flow the image filtering techniques provided from teachable machine.

Then create a combination through visual basic or C++ to communicate input output signals via USB port to access external microcontroller which handle the sensors and actuators.

At the computer level, the researchers expect to upload our calculated number of tiles into IOT database which is freely accessible over internet.

System overview step by step,

Step 1: A personal computer user with a related image processing software program to process, compare and recognize the images taken by the camera.

Step 2: personal computer transmits signals over universal serial bus (USB) communication to Arduino mega2560 to take relevant commands.

Step 3: Arduino mega 2560 then operate the conveyor feeder mechanism and sorting mechanism with attached actuators and sensor network.

Step 4: Ceramic tiles from each category collects at a relevant location on the moving pallet.

Step 5: The counted data is uploaded into the IoT server through Wi-Fi.

Step 6: DC Power supply is used to power up the system & other components.

When the final prototype control system is powered up, at first it rotates the main conveyor with DC motor concerning the command given from Arduino mega 2560 into a relay module, while at that



time the positioning pallet recognizes its initial position with the help of the stepper motor and inductive proximity sensor.(Boukouvelas et al., 1998) Then the tile can feed into the conveyor and it comes under the camera lens and the IR photosensor recognizes the tile’s presence there and signals that into the mega 2560. Then the conveyor stops, and the PC program capture button needs to be pressed at this moment. After 5sec later, the conveyor starts again, and the tile comes into ejecting position and stops there using another IR photosensor. Simultaneously, the PC compute which type of tile arrived there using the image processing and filtering algorithm allocated with the teachable machine program. This is displayed on the side of the PC screen. Also, PC signals to Arduino mega 2560 via USB port to move positioning pallet into the preprogrammed position based on the type of tile. As a result, that stepper motor rotates with the mounted thread screw until the relevant number of steps are completed. After completion, the mega 2560 energizes the ejecting mechanism attached stepper motor and it also rotates based on preprogrammed steps and push out the tile from the conveyor into the pallet and reverse back to the initial position until it reaches that placed limit switch there in the mechanism. The next tile can then be fed into a conveyor for the sorting process. After the fabrication process, all the sensors and actuators are installed into the mechanism and all the wiring with those with Arduino board and power supply was completed. Final testing and tuning on both further programming and hardware implementations were completed.

### 3. RESULTS

#### Identification of tiles over computer vision

Here are some test results on sorted tiles on white tile and textured tile

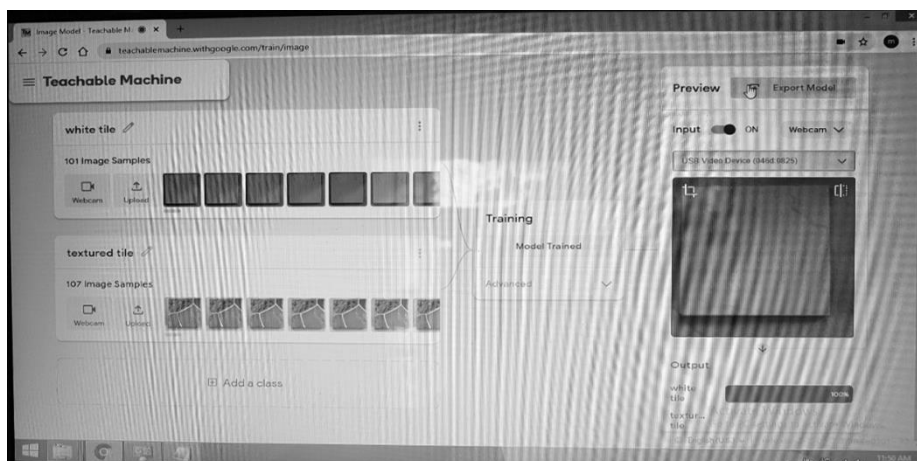

Figure 2: Computer Vision of Tile Sorting

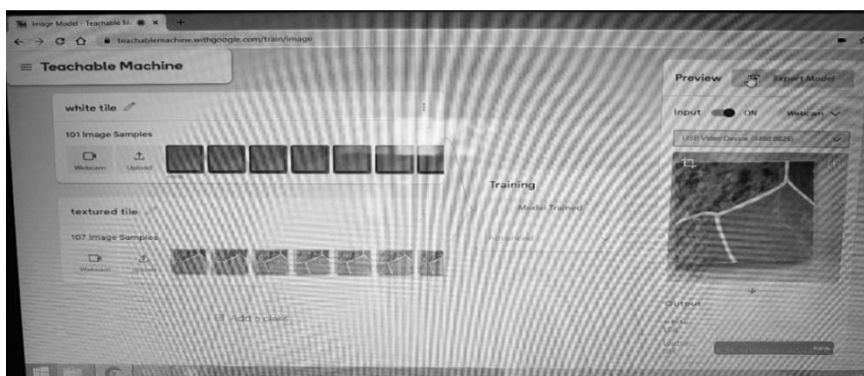
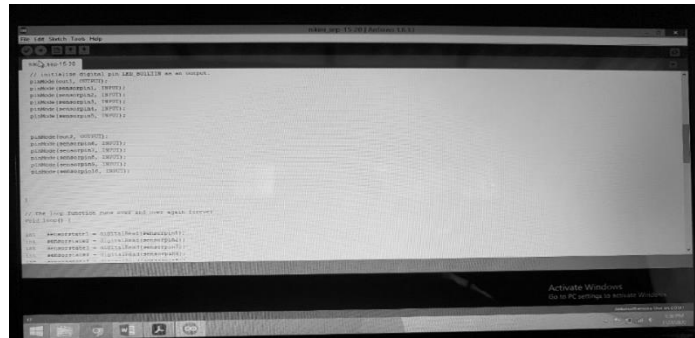

Figure 3: Computer Vision of Tile Sorting

Arduino programming interface for machine operation

Figure 4: Arduino Programming Interface



4. DISCUSSION

When it is in mechanical moving, it's better if the conveyor drive motor is replaced with the stepper motor or an encoder is a driven motor such as a servo motor. This helps to position the conveyor easily with the moving palette mechanism.

An image identification process is needed to maintain better light conditions and high accurately trained models with high-quality images. There should be a better camera to accomplish this task and that camera should be compatible with our programming platform. Otherwise, it may be a more complicated task in programming and making a trained model. This also will give some communication issues while communicating with a personal computer and lower end microcontroller interface. The project was initially proposed with a pixy2 camera for image processing, but in the local market it was unavailable and the attempt of ordering it online was also unsuccessful due to the situation worldwide.

The researchers choose a web camera as an alternate solution for the image processing task by using a personal computer and processing programming platform. It became a more complicated task in identifying cracks and damages in ceramic tiles using this method due to the lack of algorithms. Therefore, we used both colour spectrum sensor and web camera for better identification of tile category. It is better to select a raspberry pi motherboard for this kind of image processing project rather than Arduino at mega 2560 microcontroller because raspberry pi has a high-end microcontroller included with it and it's more suitable for image processing tasks.

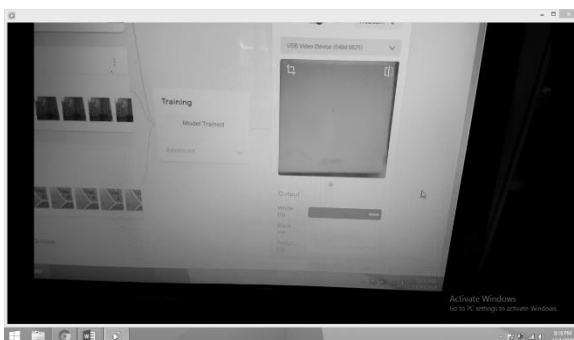

Figure 5: Detected Glaze Tile

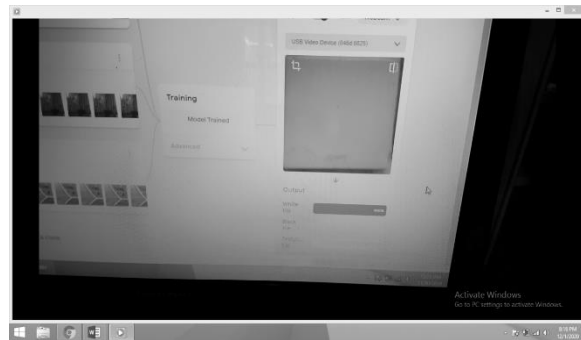

Figure 6: Detected Pattern Tile

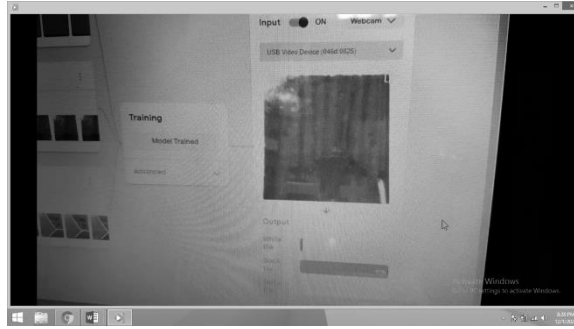

Figure 7: Detected Damage Tile

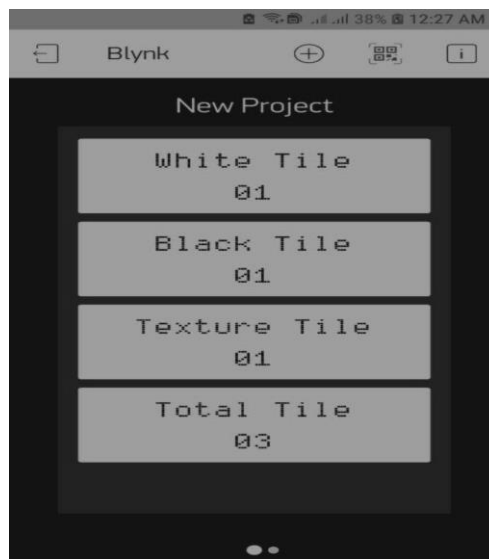

Figure 8: Detected Tiles

## 5. CONCLUSION

After our fabrication process the researchers are going to install all the sensors and actuators in to there and after complete all the wiring with those with Arduino board and power supply.

Then the researchers expect to do the final testing on both further programming and hardware implementations. There is a wide usage of products in our day-to-day life, and manufacturing and handling of these products are done in many large scales and small-scale industries. Re-arranging them in to keep track is a quality consistency issue. Nowadays the main difficulty that is faced after the production is to sort and categorize their products according to their quality.

According to our knowledge, we did this project, But with advanced future technology this OBJECT DETECTION will take place in the whole world not only object sorting but also transporting, medical science ETC. if it is used image processing with the higher advanced equipment such as high resolution camera, if ARDUINO replaced with RASBERRY PIE technology this object detecting machine will work very precisely.

## REFERENCES

- Ahmadyfard A, Alimohamadi H, Shariati A, Moghtader S (2009) A Novel Approach for Detecting Defects of Random Textured Tiles Using Gabor Wavelet 7.
- Boukouvalas C, De Natale F, De Toni G, Kittler J, Marik R, Mirmehdi M, Petrou M, Le Roy P, Salgari R, Vernazza G (1998) ASSIST: automatic system for surface inspection and sorting of tiles. *J. Mater. Process. Technol.* 82, 179–188. [https://doi.org/10.1016/S0924-0136\(98\)00044-2](https://doi.org/10.1016/S0924-0136(98)00044-2)

- Boukouvalas C, Kittler J, Marik R, Mirmehdi M, Petrou M n.d. Ceramic tile inspection for colour and structural defects 11.
- Dehler M (2003) Optical Sorting of Ceramic Raw Material 19, 4.
- Elbehiery H.M n.d. Surface defects detection for fired ceramic tiles using Monochrome and Color image processing analysis 9.
- Hocenski Z, Keser T, Baumgartner A (2007) A Simple and Efficient Method for Ceramic Tile Surface Defects Detection, in: 2007 IEEE International Symposium on Industrial Electronics. Presented at the 2007 IEEE International Symposium on Industrial Electronics, IEEE, Vigo, Spain, pp. 1606–1611. <https://doi.org/10.1109/ISIE.2007.4374844>
- Kukkonen S (2001) Color features for quality control in ceramic tile industry. Opt. Eng. 40, 170. <https://doi.org/10.1117/1.1339877>
- Mishra R, Chandrakar C.L, Mishra R (2012) Surface defects detection for ceramic tiles using image processing and morphological techniques. Appl. Sci, 2-17.

# Remote Controlled Solar Powered Grass Cutter

Ravindra Koggalage<sup>1</sup>, S.R.M.P. Seneviratne<sup>2\*</sup>, R M C Lakmal<sup>1</sup>, H W A Eshana<sup>1</sup>, M. Aathawan<sup>1</sup>

<sup>1</sup>Department of Electrical and Electronics Technology, University of Vocational Technology, Sri Lanka

<sup>2</sup>Department of Quantity Surveying, University of Vocational Technology, Sri Lanka

## ABSTRACT

*Mowing the grass is a long and laborious process. The technology available currently for cutting grass is primarily a manually operated gasoline/diesel mower. Such devices that use fossil fuels as an energy source emit greenhouse gases and pollute the environment, which can be responsible for climate changes that are negative. Grass cutters also behave as a source of noise pollution which adversely affects the health of the operator and the audibility of people in the environment. Another point to consider is the cost of fuel. To alleviate the problems associated with a conventional lawnmower, an automatic solar-powered trimmer has been designed. The designed device uses a remote-controlled HC-06 as a Bluetooth module applied in wireless communication in the mode of Bluetooth compatible devices, for communication on the Bluetooth frequency by microcontrollers with a sequential communication (USART). Because of renewable, non-polluting and free usage of energy Solar energy are chosen. The results show in test mode as it can be identified with a variety of cutting models and patterns as needed.*

**Keywords:** Battery, Cutter Blade, Sensors, Solar Panel.

## 1. INTRODUCTION

Grass cutting with a standard motor-powered device is not a process of pleasure. The process of cutting grass with existing machines cannot be easily accomplished users due to operational difficulty. The grass trimmer with the engine causes noise from the noisy engine and acts as a source of air pollution from the combustion process of the engine. In addition, a motorized engine requires regular maintenance, for instance, maintenance activities as changing the engine oil. While electric grass is environmentally friendly, it can also be a drawback. In addition to motorized lawnmowers, electric lawnmowers are also dangerous and not all of them can run smoothly. In addition, mowing can be problematic and dangerous when the electric trimmer is connected to the main power source by cords.

The presented prototype in this project as a substitute over the diesel-controlled grass cutter machine will be charged from the sun by using solar panels to avoid these problems. An automatic solar-powered grass cutter is designed to have a remote controller (HC-06 is a Bluetooth module used at wireless communication) as Bluetooth device enabled to communicate via Bluetooth frequency with microcontrollers using serial communication (USART) to control the device.

## 2. PROBLEM STATEMENT

Considering the grass cutting activity it is a time-consuming and also a labor-consumer process. Usually, as a method of grass cutting is a manually handled Diesel/ petrol operated cutter, as operated using fossil fuel as the sources of energy. Fossil fuel as a source of energy emits greenhouse gases (CO<sub>2</sub>) and could be responsible for negative climate changes, as well as the higher cost of fuel. At the same time grass cutters behave as a source of noise pollution that affects the operator's health and the adjacent listening group. Therefore, in this project mitigating these problems of the conventional cutter was considered to develop a solar-powered automatic grass cutter.

---

\* Corresponding author: E mail - [srmpseneviratnaunivotec@gmail.com](mailto:srmpseneviratnaunivotec@gmail.com)

### 3. LITERATURE REVIEW

Edwin Bading invented the first lawnmower in Gloucestershire, England, in 1830. Later after 20 years to make an animal tow for new updates and innovations, and more than 50 years to make a steam cutter. In 1850, Thomas Green introduced Silence Messer (silent cutter). He used a chain drive to transfer power from the rear roller to the cutter roller (Schneiderman M. n.d).

There is a number of studies and experiments going on in many countries on how to use solar energy to reduce bad environmental effects. Also with the shortage of human labor, many researchers focused on how to automate the machines which are used by humans. For instance, Refactoring engines automate a key component of the modern IDEs, the earlier the user selects a refactoring applied, later engine is inspected alteration safety, with sufficient situations transforming the program. (Daniel, Dig, Garcia., Marinov., 2007)

Frequent overcharging and discharging of battery might badly affect the life span of the battery and to overcome that problem a charging controller was experimented with by Amey. et al. (2017). The solar energy trapped in photovoltaic cells thus generates electricity has been used in this machine. In order to absorb the high-intensity rays coming from the sun solar panel is tilted at a 45-degree angle. It uses a circuit breaker to start or stop the engine mortar. Considering ground clearance, it can be in tune according to the height of the lawn. Solar lawnmowers in this context can be used with minimal effort. The given program is delivered to the computer and the robot moves according to the given pattern in the grass.

According to the design of Baltha (2017), a solar panel mounted on a grass cutter produces solar energy that is used at the device. It also uses the circuit of the driver to control motor speed when needed. To avoid overcharging and discharging the battery, the controller/regulator was built into the system and installed in series. It is equipped with an LCD display that emits electrical energy when it catches the sunlight. Due to seasonal conditions, an electric bank to charge the battery can be used if the battery is not charged.

Mudda (2018) discussed the way they made a hand-held grass cutter with a spiral rotary cutter, which improves the cutting efficiency by the spiral blade. A reel cutter is placed on the grass cutter to adjust the height. While the working battery can be charged and there is also an AC charging option. Place a container on the mower so that it can be placed outside the lawn to pick up the grass clippings. Lightweight and compact design.

Therefore, the objective of the research is to develop a solar-powered automatic grass cutter to mitigate the related problems of conventional grass cutters.

### 4. METHODOLOGY

An experimental design is advanced to develop a solar-powered automatic grass cutter with a remote controller. As shown in figure 2, the machine consists of a direct current (DC) motor, a DC battery, a solar panel, a stainless-steel blade, and a remote controller. In this device, power is generated through the solar panels mounted on the grass cutter was supplied through a battery Device, over a charger controller to the Microcontroller, which connects the devise Motor drive at a DC motor to work out the grass cutter.

#### 4.1 Principals of Design

The device is mounted on four wheels and at a plywood panel. The two front wheels are designed as rotating wheels in order to make the cutter turn in a direction. The solar panel is mounted on top of the model in a particular arrangement such that the angle of inclination is 45 degrees hence it can be received high-intensity solar radiation easily.

One of the basic principles behind this design is the photovoltaic aspect to develop electricity as Solar power.

#### 4.1.1. Photovoltaic Principles:

In various materials, the photovoltaic effect can be observed in nature, and the above semiconductor showed the best performance in sunlight. Photons of the sun are absorbed by semiconductors, to produce free electrons of higher energy, as at an electric field that allows these high-energy electrons to flow out of the semiconductor. Due to the interaction of semiconductor photons, the intersection of materials with different electrical properties provides an electric field for most solar cells. The solar cell consists of the following main parts; 1. A semiconductor as electron-hole pairs formed to the immersion of solar radiation. 2. Drift field for charge separation and 3. Charge to gathering front/back electrodes.

#### 4.2 Alternatives Solar Panel Design

Among the alternative replacement patterns of Solar panels, a pattern of 03 Solar Panels setting installed in the prototype was to arranged, in such a manner to arrange maximum possible sunlight. One panel is placed horizontally and the other 2 panels are placed at 45 degrees angle on either side of the first one, such that when the sun rays fall on the panels, more photons can be absorbed. External power supply and solar panel are used to charge the battery as required.

#### 4.3 Alternatives Directions of Cutting Blades

A DC controllable motor is used for changing the direction of the cutting blade. In order to test the selected design, the following procedure described in section 5.4 is followed.

#### 4.4 Testing

Final product of the solar powered grass cutter has been tested on a Lawn as shown in Figure 1, and it managed to cut various patterns. Carefully completing and delineating the existence of all modules contributes to the optimal functioning of the unit. Second, with the help of constantly evolving technology, the project was successfully implemented using advanced CIs. Therefore, the project was successfully designed and tested.



Figure 1: Testing the solar powered grass cutter on a lawn

### 5. COMPONENTS IN DESIGN

Components used in this equipment are described as a solar panel, device of battery, a power charger regulator, and a blue tooth module.

Solar panels use sunlight as a source of energy to generate direct current electricity. In the design as a 20-watt solar panel will not be capable to handle the equipment a battery is used to store the power, as solar power is used to charge a battery, then after a period of time, the accumulated stored energy can be used to operate the appliance.

Batteries are also used as solar energy storage devices, which convert solar power to electrical energy. The sunlight loads are considered for such as applications for irrigation pumps and drinking water jets, which are used to store small appliances with a power of under 1 kW. The only storage method that is technically and economically available in the battery. The capital cost of solar and battery systems is high, so the entire system needs to be optimized for available energy and regional demand patterns. Store economically attractive photovoltaic batteries with a combination of the special features as; 1. low cost, 2. durability, 3. reliability, and 4. high efficiency.

This solar grass cutter was designed as its battery could be removed. So that, on rainy days another pre-charged battery can be used and it was hoped to use this machine in rainy days.

Regulators for Power supply charge similarly called charge regulators and voltage regulators. The regulator is placed between the panel matrix, the battery and the device or load. The voltage regulator monitors the battery voltage to prevent overcharging or over-discharge.

Apart from the devices discussed above, a Bluetooth module was used. One of the Bluetooth unit used is HC-06 applied with wireless communication with compatible Bluetooth devices (such as smartphones and Bluetooth controllers, etc.). It uses serial communication (USART) to communicate with the microcontroller through the Bluetooth frequency.

A 45 ° angle placed for solar panels to obtain the maximum strength of solar radiation. Panel connects charge controller to battery to protect the battery from over-charging. The battery is connected to DC motor. The blades are fastened to the motor. Microcontrollers with remote controls are used for automation purposes. The ultrasonic sensor and temperature sensor is linked to microcontroller. Ultrasonic sensors are used to detect obstructions. Temperature sensors are used to detect temperature, sending signals, slow down the motor speed as needed to avoid overheating, and reduce damage caused for unbroken use. When the motor temperature rises above the threshold temperature, the microcontroller sends a signal to control the motor speed.

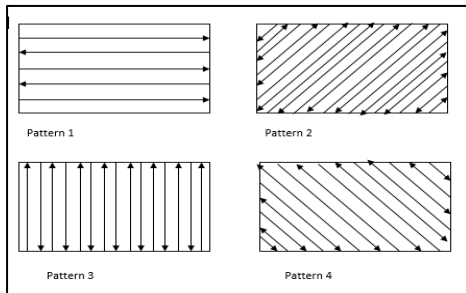

Figure 3: Cutting patterns of designed remote controlled solar grass cutter

This remote-controlled solar power grass cutter gets fully charged in 04 hours and after full charged it can be used for 07 working hours. It has front light for working at night time. The battery can charge with solar energy or normal power. This is similar to use of remote-controlled car with simple operational buttons, and can be used by any person without any additional skills. Cutting speed and running speed can be changed by the remote controller. DC motor (Cutting motor) can be adjusted to have two modes, on or off. Moreover, it is possible to select different cutting patterns as shown in Figure 3.

## 6. RESULTS

A Schematic diagram of the design is shown in Figure 4.

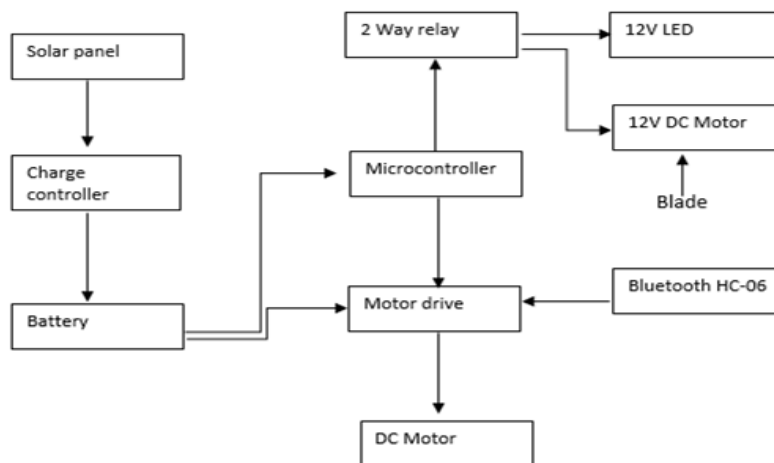

Figure 4: Schematic diagram of the design



Calculation for solar panel design is given in Figure 5.

- Load calculation, I = Current, V = Voltage, P = VI, P = Power  
 Solar panel rated power = 20W      DC motor rated voltage = 24V  
 DC motor rated current = 1.6A      DC battery rated voltage = 12V  
 DC battery Ampere hour = 7Ah  
 Assumptions are: Efficiency of  
 Solar panel = 18%, DC = 85%, Battery charging/discharging = 95%  
 Operate hour per day = 1hr
- Power for DC motor = Voltage \* Current  
 $= 24 \text{ W} * 1.6 \text{ A} = 38.4 \text{ W}$
- Wheel and the blades output power supply (DC motor)  
 $= \text{DC motor power} * \text{DC motor efficiency}$   
 $= 38.4 \text{ W} * 0.85 = 32.64 \text{ W}$
- Solar panel output power  
 $= \text{Solar panel rated power} * \text{Solar panel efficiency}$   
 $= 20$   
 $= 20 * 0.18 = 3.6 \text{ W}$

Figure 5: Calculation for Solar Power Design

Calculation for the battery design is given in Figure 6 and the DC motor design is given in Figure 7.

- DC motor Input power requirement (per day) = DC motor power \* Operate hour per day  
 $= 38.4 \text{ W} * 1\text{hr}$   
 $= 38.4 \text{ Wh}$
- Dc motor Number of days  
 operates as battery is full charged = motor/Input power requirement of the DC motor  
 (Output power of the DC battery supplied per day)  
 $= \frac{79.8 \text{ Wh}}{38.4 \text{ Wh}}$   
 $= 2.078 \text{ days}$   
 $= 2 \text{ days}$

Figure 6: Calculation for Battery Design

Fully charge of battery (Time required) = (DC battery rated voltage \* DC battery Ampere hour) / Output power of the solar panel  
 $= \frac{(12 \text{ V} * 7 \text{ Ah})}{3.6 \text{ W}}$   
 $= 23 \text{ hours}$

DC battery supplied to motor (Output power) = Battery charging \* DC battery rated voltage \* DC battery ampere hour  
 $= 0.95 * 12 * 7$   
 $= 79.8 \text{ Wh}$

Figure 7: Calculation for DC Motor Design

The final Product is shown in Figure 8 and Figure 9.

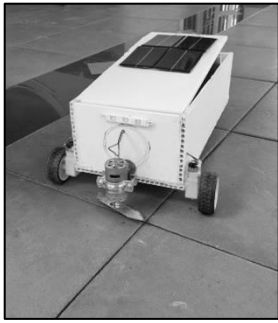

Figure 8: Remote controlled solar power grass cutter

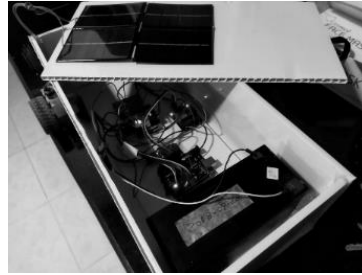

Figure 9: Inside of the remote-controlled solar power grass cutter

## 7. CONCLUSION

Design and implementation data about the solar-powered grass cutting machine was implemented in the paper. It has been designed in such a way that the solar panels produce solar energy for running the grass cutter motor. This has met the challenge of environmental protection and low cost of operation as no fuel costing. Therefore, the developed machine device provides a feasible replacement for a gasoline-powered grass cutter.

In this research, the device was designed to develop as a solar-powered automatic grass cutter that will mitigate the problems related to conventional grass cutters. The green energy produced by the solar panels mounted on top of the device will transfer the power through the Microcontroller to drive the device, through a battery conceive through a charger controller. Microcontroller connects the devise Motor drive at a DC motor to run the system devise. This solar-powered grasscutter can be used to obtain different cutting patterns as shown in the results. The solar-powered lawn mower has been developed to use in smaller areas where tractor-driven movers cannot be used. The developed machine surely reaches the average family because the grass can be trimmed with minimum cost and with minimum time. It also can easily be operated by anyone without any difficulty by using the remote controller at the Bluetooth module.

## 8. FUTURE EXTENSION

The project was successfully completed with the available resources to have a solar grass cutter as proposed. But the results and modifications are not up to the expectations due to various limitations with this pandemic situation. At alternative designs, certain attempts were identified in the Solar-powered grass cutter that is capable of alphabet printing mechanism in the grass, which in this machine certain parallel lines as patterns were detected as to implement over the testing. In certain devices for Solar-powered grass cutters pesticide sprayer was also attached with the grass cutter, yet in the device these applications are yet to develop. The device can be further improved by incorporating the following modifications to obtain better results. The efficiency can be increased by using some other improved mechanism. The operating speed of the motor has been reduced because of the heavy material used. This material can be replaced by using light weight material such as PVC. The design of blades should be done based on the types of grass to be cut. Another possibility is to use wind power motor for charging procedure. Finally, it is assumed that the project provides inspiration to the public to modify the device as per possible changes to obtain better results.

**REFERENCES**

- Amey, A., Shenai, Saurabh, S. D., & Ganesh, M. M. 2017. Solar Powered Remote Controlled Multipurpose Grass/Paddy Cutting Machine. *International Journal of Advance Research in Science and Engineering*, 1, pp.999-1003.
- Daniel B., Dig D., Garcia K., Marinov, D. 2007. Automated testing of refactoring engines”, Proceedings of the 6th joint meeting of the European software engineering conference symposium on The foundations of software engineering, 2007
- K, S. K., G, S. S., Baltha, M. K., & D, S. V. “Design of Remote Controlled Solar Grass”, *International Journal of Innovative Research in Science*, vol.12, 2017.
- Mudda, M. “Automatic Solar Grass Cutter.”, *International Journal for Research in Applied Science & Engineering Technology (IJRASET)*, vol.4, pp.1148-1151, doi:10.22214, 2018.
- Prabhat, K. D., & Jain, H. “Experimental Study of Solar Power Grass Cutter Robot.” *Journal of Advance Research and Innovative Ideas in Education*, vol.2, pp.69-73,2016.
- Sagar, V. P., Kunal, P., Rahul, C. A., & Ganesh, L. “Solar Powered Automated Grass Cutter Machine”. *International Research Journal of Engineering and Technology (Irjet)*, vol.4, pp. 2318-2321, 2018.
- Schneiderman M., “Edwin Budding and His Pepperbox: A 21st Century Update”, *Society of Arms Collectors Bulletin* 104:55-64 Additional articles  
<http://americansocietyoffarmscollectors.org/resources/articles/>
- T. Karthick, S. L. “Grass Cutting Machine Using Solar Energy.” *International Journal of Research in Mechanical, Mechatronics and Automobile Engineering*, 2016.
- Tanmay, B., Nikhil, B., Karan, D., Rahul, G., & Sheetal, J. “Environmental friendly solar grass cutter”, *International journal of research in engineering, science and management*, vol.7, pp.178-179, 2020.

## **EMERGING TECHNOLOGIES IN THE MANUFACTURING SECTOR**

# An Economic Assessment of Rooftop Solar Photovoltaic in Northern Province of Sri Lanka

Thushana Uruthiran\*, Sampath Ediriweera

Department of Electrotechnology, Wayamba University of Sri Lanka

## ABSTRACT

*As a result of the growing population, the demand now met by fossil fuels is gradually increasing. The depletion of fossil fuel supplies due to global warming, and rising power rates have introduced alternative energy technologies such as wind and solar. The Northern Province of Sri Lanka has a high solar potential and an excellent environment for solar power generation, and solar photovoltaic (PV) systems on rooftops have been brought to the household level by the government and the private sector. This study aimed at improving the knowledge of financial limits linked to solar PV in the Northern Province, Sri Lanka, such as the levelized cost of energy and payback period. To assess the cost competitiveness of rooftop solar systems, a case study on an existing rooftop solar system was undertaken. To evaluate the impact of external elements such as the electricity rate, discount rate, and energy usage on financial difficulties, a sensitivity analysis was employed. According to the payback duration and energy cost of the system, the rooftop solar systems built in the Northern region are cost-competitive. The findings also suggest that external variables such as the discount rate have a significant impact on financial problems.*

**Keywords:** Cost Analysis; Cost Competitiveness; Payback Period; Sensitivity Analysis; Solar Photovoltaic.

## 1. INTRODUCTION

Sri Lanka with a land space of 65,610 square kilometers is a small island located in the Indian ocean and it has 22 million populations (Fernando *et al.*, 2017). Thermal energy power plants, such as fossil fuel energy sources, account for the majority of Sri Lanka's current energy generation (diesel and coal). According to a recent study, solar is a more promising technology than wind in terms of environmental consequences if the country's energy mix is entirely made up of renewable energy sources. As a result, solar technology can account for an important role in the transformation of the future to carbon neutrality (Liyanage, 2020). The northern part of the country has a high solar electric potential, with daily radiation of around 3.8 kWh/m<sup>2</sup> and yearly radiation of around 1387 kWh/m<sup>2</sup> in the Northern Province of Sri Lanka. Many solar projects in the Northern Province have been approved until April 2021.

Several studies argue that economical and financial barriers play a vital role when it comes to adopting renewable energy systems. Although the solar potential is high in Sri Lanka and the growth rate of solar power is increasing continually, but there are many barriers related to solar PV. Solar PV technology requires relatively high capital investment and large areas for installation to produce a sufficient amount of electricity due to the low energy-generating efficiency (Painuly, 2001). According to a study, a long payback period is a financial barrier faced by rooftop solar investors, and components of the barriers include low profits, insufficient incentives, and high-income taxes (Almaktaret *et al.*, 2016).

This paper presents a study to deepen understanding of the two financial challenges that stop the households and investors in the Northern Province, Sri Lanka from investing and installing in grid-connected solar projects: Levelized cost of energy and payback period incorporating the fluctuation of electricity rates, discount rate, and energy consumption through conducting a case study. Section 2 presents the details on the existing rooftop solar installation in the Northern Province and the details of conducting the cost analysis and sensitivities analysis. Then, section 3 elaborates the results and finally, the conclusion of the paper is presented in section 4.

---

\* Corresponding author: E mail - [thushathushana@gmail.com](mailto:thushathushana@gmail.com)

## 2. METHODOLOGY

The research investigates whether a grid-connected solar system installed on a roof of a house in the Northern province is cost-competitive and can meet household payback period requirements. To solve the research problems, a case study and an electricity consumption analysis are used. Also, a sensitivity analysis is carried out. In addition, a comparison is done for the case study and electricity consumption analysis with a literature review. Details on the case study, Levelized cost of energy, the payback period, and the sensitivity analysis are elaborated in the following subsections.

### 2.1. Case Study in Jaffna District in Northern Province

A case study for a net accounting scheme was conducted from November 2017 to October 2018 for a building complex named Suharni Health Complex of which the owner is Dr. Sivansuthan and it is located in Jaffna district, Northern Province of Sri Lanka. The building consists of electric equipment such as refrigerators, computers, fans, and televisions other than the dental equipment such as MRI machines, ECG monitors, and dental patient chairs.

The grid-connected rooftop solar power generation project considered in this study was installed in the building on November 19, 2017. J Lanka, a leading solar distributor in Sri Lanka was chosen by the customer to install the solar panels on the rooftop. Solar panels rated at 300 W were offered and 140 such solar panels were installed on the roof facing south at an angle of  $10^0$  resulting in a total 42 kW capacity. Before the solar PV system is installed on the rooftop, it had the electricity supply from the grid under the general purpose-1 category which charges 18.30 LKR/ kWh with the consumption below 300 kWh and 22.85 LKR/ kWh with the consumption above 300 kWh with a fixed charge of 240LKR.

In the net accounting scheme, if the generation of the solar system (export units) is higher than the consumption (import units), the consumer will get 22 LKR per kWh for the first 7 years of the solar project life-cycle and 15.50 LKR per kWh after 7 years. Data such as installation cost of solar, monthly consumption, and monthly generation were collected for the analysis purpose.

### 2.2. Levelized Cost of Energy

Levelized cost of energy (LCOE) is the common method for comparing different power generation technologies. It is calculated by dividing the Total Life Cycle Cost (TLCC) of the energy-generating technology by the generated energy. The cost competitiveness of multiple power generation technologies can be analyzed by comparing LCOE between them. (Razaet *al.*, 2015). The formula for calculating LCOE is illustrated in (Eq:1).

$$LCOE = \frac{TLCC}{\sum_{n=1}^n \frac{Q_n}{(1+d)^n}} \quad (\text{Eq:1})$$

Where,

$Q_n$ - Unit (energy) consumption in month n.       $P_n$ - Unit (energy) production in month n.

P - Unit price.      I - Initial investment cost.      d – Discount rate

LCOE is an economic assessment of the cost of a power-generating technology, incorporating all costs over its lifecycles, such as capital cost, operation and maintenance, fuel costs, and capital costs. (Krebs, 2012). In this study, the initial investment cost and the cost of electricity taken from the PV system are considered as two main components of the cost. J Lanka offers free regular services and inspections resulting in a minimal maintenance cost. To define the cost competitiveness of grid-connected rooftop solar systems, comparing the LCOE in absence of the solar PV system is necessary. The formulas for calculating the TLCC in absence of the solar system and with the installed solar system are illustrated in (Eq:2) and (Eq:3) respectively. TLCC is calculated through energy consumption, electricity rate, discount rate, and analyzing period (years)

$$TLCC_{no-PV} = \sum_{n=1}^n \frac{(Q_n * P)}{(1+d)^n} \quad (\text{Eq: 2})$$

$$TLCC_{w-PV} = \sum_1^n \frac{(Pn-Qn)*P}{(1+d)^n} + I \quad (\text{Eq: 3})$$

Where,

$Q_n$  - Unit (energy) consumption in month  $n$        $P_n$  - Unit (energy) production in month  $n$

$P$  - Unit price       $I$  - Initial investment cost       $d$  - discount rate

Past investments in different energy technologies have shown that the discount rate depends on different factors such as taxes, interest rates, and planning horizons. Defining the discount rate is a difficult task so therefore, a real discount rate of 10 % has been used in this study (Short *et al.*, 1995). The efficiency of solar panels is getting decline due to different reasons such as chemical reactions and radiation (Krebs, 2012).

The degradation is an important aspect to be considered in evaluating LCOE and the payback period. So, a degradation rate of 0.5 % per year is considered (Jordan and Kurtz, 2013).

### 2.3. Payback Period

The payback period is the time required to recover the cost of the investment of the system. After solar installation, monthly savings depend on monthly production and consumption. If the production exceeds consumption, the monthly electricity cost is found by considering the difference between the production and the consumption and multiplying it by the electricity rate (unit rate). Monthly saving and the simple payback period are given by (Eq:4) and (Eq:5) respectively

$$S_n = Q_n * P1 + (Q_n - P_n) * P2 \quad (\text{Eq:4})$$

$$\text{Payback Period} = \frac{\text{Investment}}{\text{Savings in month}} \quad (\text{Eq:5})$$

Where,

$S_n$  = Savings in month  $n$        $Q_n$  = Energy consumption in month  $n$

$P_n$  = Energy production in month  $n$

$P1$  = Electricity rate (if  $Q_n$  units are taken from the grid)

$P2$  = Electricity rate (if  $Q_n - P_n$  units are taken from the grid)

### 2.4. Sensitivity Analysis

Sensitivity analysis was performed to see the effect of various inputs on the financial barriers of PV solar system installation and operation (Board, 2011). The parameters considered for the study are electricity rate, discount rate, and energy consumption. There are different ways to conduct sensitivity analysis. The technique used in this study is one-at-a-time (OAT) (Jovanović, 1999). OAT analysis determines which parameter affects the output and then it analyzes the behavior of the output while changing only one parameter with keeping the other parameters fixed.

## 3. RESULT AND DISCUSSION

LCOE values with the grid-connected PV system and without the PV system are found to be -11.46 LKR/ kWh and 23.16 LKR/ kWh. Investments in rooftop solar systems have resulted in lower LCOE costs than those without grid-connected solar systems. The net profit due to the surplus generation in every month of the year has made the LCOE of the PV system to be negative. At the end of the solar system's life cycle, consumers received a benefit for each unit of energy consumed.

Figure 1 illustrates the changes in the average cost of energy between the no-grid connected PV system and grid-connected PV system for 25 years. The average cost of a grid-connected solar system drops sharply to 7 years, even if initially the average cost of electricity is higher than that of a no grid-connected solar system.

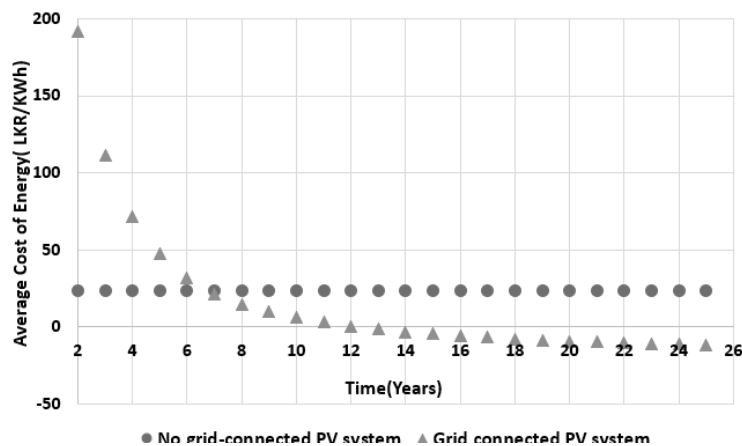

Figure 1: Average Cost of Energy with Time

Then it follows a gradual reduction which has been affected by the electricity rate change for surplus energy just after 7 years. The payback period for the grid-connected solar system is evaluated as 4 years and 9 months. However, the studies in Sri Lanka are not enough to get an idea about the acceptable payback period of rooftop solar systems. But, studies of the payback period on energy-related investment from Europe can be found (Moula, *et al.*, 2013). The researchers conducted in Switzerland estimated payback periods of 10 years or less to be acceptable, whereas studies in Finland and Denmark project 6-9 and 7-8 years respectively. Therefore, the cost competitiveness was achieved by installing the solar system in the Northern Province.

To find out the effect of the electricity rate on the LCOE values and the payback period, all electricity rates have been increased by 5%, 10%, and 15%. Figure 2 illustrates the effect of increased electricity rate on the LCOE values.

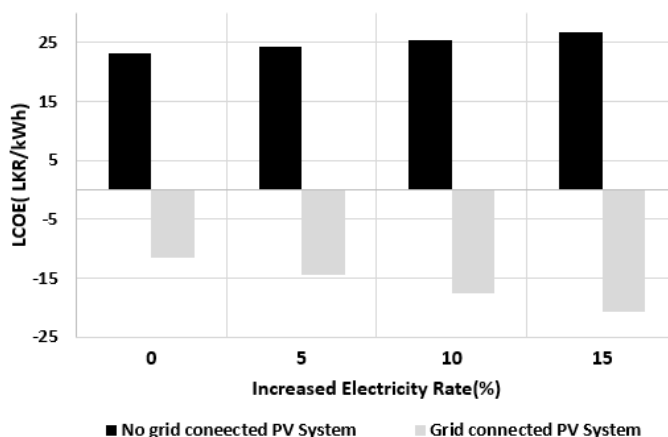

Figure 6: Variation of LCOE with Electricity Rate

LCOE without the grid-connected PV increases slightly with the electricity rates while LCOE with grid-connected solar PV system significantly decreases further. Since that the surplus energy units are higher than that the energy consumption every month, the present value of the total life cycle cost (TLCC) of the grid-connected solar system has been greatly affected by the increased electricity rate compared to the situation without a grid-connected solar system. Because this technology feeds excess energy into the power grid, higher electricity rates directly increase the cost the Ceylon Electricity Board pays consumers, increasing annual profits. Therefore, the payback period reduces with increased electricity rates. With an increasing electricity rate of 15% and 25%, the payback period becomes 4.2 years and 3 years respectively.

The discount rate has a significant impact on energy costs as it is important in determining the present value of cash flows occurring in the future. It is replaced by 15% and 18% to evaluate the effect on the



LCOE value. Figure 3 shows the variation of the LCOE with an increased discount rate. Even though the LCOE of the solar-connected system without grid connection is independent of the discount rate, the LCOE of the grid-connected solar system increases as the high discount rate lowers the present values of the future profits. Therefore, as the discount rate increases, the technology becomes less competitive. The simple payback period is independent of the discount rate as depicted in previous studies (Renn et *et al.*, 2003).

An analysis is conducted to determine the effect of energy consumption on cost competitiveness. Figure 4 and Figure 5 illustrate the variation of LCOE and the payback period respectively with varying electricity consumption. LCOE of grid-connected PV connected system and no-grid PV connected system varies quasilinearly with the electricity consumption holding almost same rate of changes in the considered range.

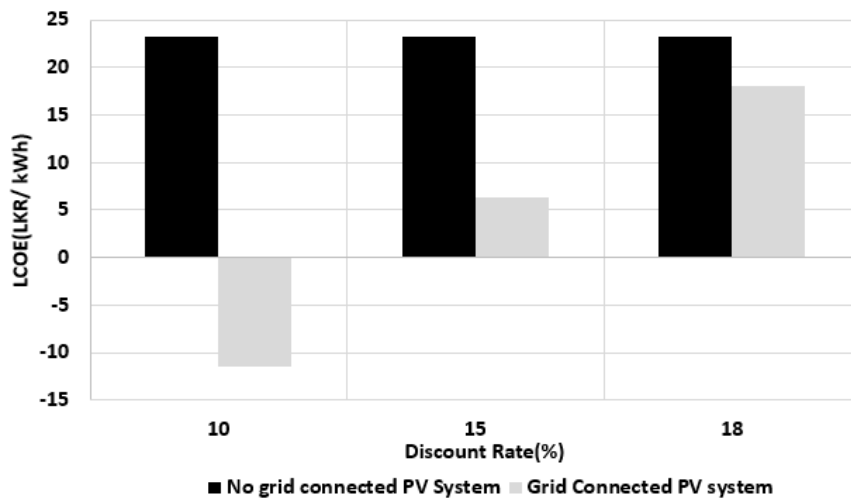

Figure 7: Variation of LCOE With Discount Rate

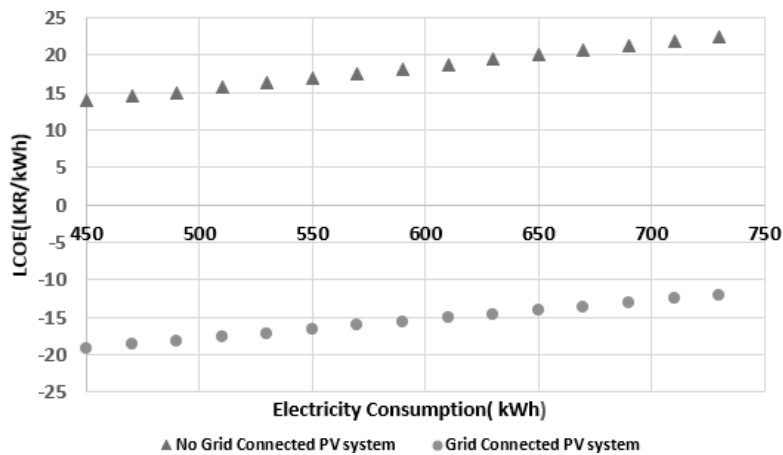

Figure 8: Variation of LCOE with electricity consumption

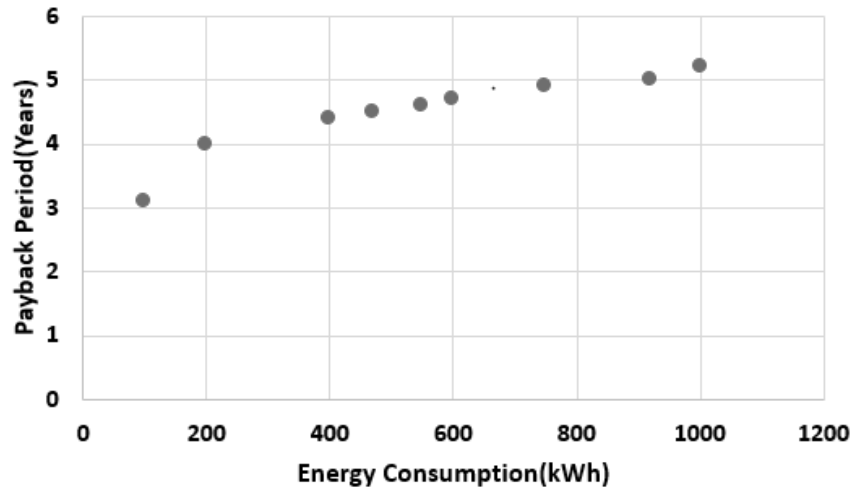

Figure 9: Variation of payback period with electricity consumption

LCOE of PV-connected system is lower than that no-grid PV connected system irrespective of the electricity consumption and the increasing energy consumption makes the value of LCOE increase in both systems. The payback period increases with increasing monthly energy consumption. When energy consumption is 100kWh, its payback period becomes 3-4 years and with energy consumption of 1000kWh, its payback period is 5-6 years.

#### 4. CONCLUSION

In this paper, two financial barriers that prevent households, in the Northern Province of Sri Lanka from investing in the grid-connected PV systems are addressed to increase the understanding of the viability of the rooftop solar system. Based upon a case study of net accounting scheme and assuming on several assumptions such as an annual discount rate of 10 % and same energy consumption pattern in every year, the rooftop solar system in the province is proven to be cost-competitive with a simple payback period of 4 years and 9 months. Sensitivity analysis has great importance on the cost competitiveness of grid-connected rooftop solar systems. Parameters such as electricity rate, discount rate, and energy consumption are changed to see the results of LCOE and simple payback period. The discount rate heavily affects the LCOE value of the grid-connected rooftop solar power projects in determining the cost competitiveness of the technology. The increase in energy consumption can increase the payback period. Therefore, factors affecting the discount rate in Northern Province should be considered in more detail to improve the accuracy. The finding of the study will be of great value to investors in Northern Province to get an understanding of whether existing systems are viable and how the external factors affect the viability.

#### REFERENCES

- Almaktar, M., Abdul Rahman, H. and Hassan, M.Y., 2016. Economic analysis using net present value and payback period: case study of a 9kWp grid-connected PV system at UTM, Johor Bahru campus. In *Applied Mechanics and Materials* (Vol. 818, pp. 119-123). Trans Tech Publications Ltd.
- Board, C.E., 2011. Statistical Digest 2013. *Internet: www.ceb.lk., [May. 15, 2012]*.
- Fernando, W., Gupta, N. and Özveren, C.S., 2017, August. The electricity infrastructure in Sri Lanka then, now and hereafter. In *2017 52nd International Universities Power Engineering Conference (UPEC)* (pp. 1-6). IEEE.
- Jordan, D.C. and Kurtz, S.R., 2013. Photovoltaic degradation rates—an analytical review. *Progress in photovoltaics: Research and Applications*, 21(1), pp.12-29.
- Jovanović, P., 1999. Application of sensitivity analysis in investment project evaluation under uncertainty and risk. *International Journal of project management*, 17(4), pp.217-222.
- Krebs, F.C. ed., 2012. *Stability and degradation of organic and polymer solar cells*. John Wiley & Sons.

- Liyanage, N., 2020. Private sector engagement in large scale solar power deployment in Sri Lanka: Role of green climate fund. *Bulletin of the Korea Photovoltaic Society*, 6(1), pp.21-34.
- Moula, M.M.E., Maula, J., Hamdy, M., Fang, T., Jung, N. and Lahdelma, R., 2013. Researching social acceptability of renewable energy technologies in Finland. *International Journal of Sustainable Built Environment*, 2(1), pp.89-98.
- Painuly, J.P., 2001. Barriers to renewable energy penetration; a framework for analysis. *Renewable energy*, 24(1), pp.73-89.
- Raza, W., Hammad, S., Shams, U., Maryam, A., Mahmood, S. and Nadeem, R., 2015. Renewable energy resources current status and barriers in their adaptation for Pakistan. *J. Bioprocess. Chem. Eng*, 3(3), pp.1-9.
- Renné, D., George, R., Marion, B., Heimiller, D. and Gueymard, C., 2003. *Solar resource assessment for Sri Lanka and Maldives* (No. NREL/TP-710-34645). National Renewable Energy Lab.(NREL), Golden, CO (United States).
- Short, W., Packey, D.J. and Holt, T., 1995. *A manual for the economic evaluation of energy efficiency and renewable energy technologies* (No. NREL/TP-462-5173). National Renewable Energy Lab., Golden, CO (United States).

# Design and Development of Vertical Axis Wind Turbine for Power Generation in Expressways

Dilan Manathunga, Tharindu Karurarathna, Ishani Kanchana, Jayalal Wettasinghe\*

Department of Mechanical and Manufacturing Technology, University of Vocational Technology, Sri Lanka

## ABSTRACT

*In our everyday lives, we require a lot of energy. The resources we utilize are limited, and many of them contribute significantly to environmental damage. As a result, there is a need to figure out how to use natural resources to generate energy. Wind energy is one such natural resource, and this research focuses on successfully harnessing wind energy at expressways in Sri Lanka through the usage of Vertical Axis Wind Turbines (VAWT). Several turbine blades were studied and compared using a simulation study to determine the optimal shape of turbine blades. The chosen VAWT blades were then designed and developed in a sevonius form, with reduced weight and stiffness, so that the air velocity generated by the driving vehicle is enough to cut the turbine blades. When the generator rotors are spinning at maximum speed, the output voltage is 20 volts. The VAWT's generated electricity is then stored in a battery. This energy may be utilized to light up street lamps and a variety of other things. The device was tested on the main roadway, and the results were positive. Those results lead to the forecasting of getting the intended results once implemented properly in an expressway.*

**Keywords:** *Sevonius Shape, VAWT, Wind Energy.*

## 1. INTRODUCTION

In everyday life, the electricity demand is far greater than the supply of electricity. The growing population and the shortage of natural resources are two key issues. Traditional fossil fuels such as oil, coal, and others provide for the majority of the global energy supply (Zheng, Song and Shen, 2021). As such a result, investing in renewable energy is more vital than ever. It was discovered that the world's fossil fuel supplies are quickly depleting, with no new sources detected. Carbon dioxide, a byproduct of fossil fuel usage, has been identified as significant to global warming. As a result, individuals are currently attempting to create alternative power-generating methods.

The use of renewable energy is critical to economic growth. Wind power has been recognized as a less expensive energy source that can be utilized to generate electricity, and because of its relevance, a great amount of research has been performed to enhance the related technologies (Aslam Bhutta et al., 2012). It is also advantageous for the environment to use abundant renewable energy sources and minimize reliance on fossil fuels. Researchers and practitioners are currently attempting to investigate new environmentally friendly sources of energy, and wind energy might be seen as a viable alternative in this regard.

This study focuses on designing and fabricating a Vertical Axis Wind Turbine (WAVT) for expressways in Sri Lanka to utilize the wind forces from moving vehicles, converting wind's kinetic energy into electrical energy. In VAWT, the turbine blades rotate perpendicular to the ground, around a vertical axis, and these types of wind turbines have been used for a very long period of time (Johari et al., 2018). In Sri Lanka, this approach has yet to be adopted. If this is successfully implemented in an expressway, the generated energy can be utilized to lighten the expressway without the usage of non-renewable energy sources.

Chapman and Wiczowski (2009) investigated the use of wind energy to power highway rest sites, weigh stations, and team section facilities with the goal of lowering electricity costs, increasing return

---

\* Corresponding Author: E-mail - [jayalal@uovt.ac.lk](mailto:jayalal@uovt.ac.lk)

on investment, reducing energy consumption, and providing educational opportunities. Natural wind resources accessible at (or near) these sites were gathered and evaluated as part of the study. These data were then utilized in combination with a variety of commercially accessible wind turbines. (Kulkarni *et al.*, 2016) designed and developed a VAWT for highway applications. Semi-circular blades are linked to a disc affixed to the shaft in this configuration. There, a bearing was used to connect the shaft to the pulley, and the pulley is linked to the alternator, which generates electricity. The energy produced is stored in a battery. (Tian *et al.*, 2017) designed a VAWT to be installed on highways and generate electricity from the wakes of passing vehicles on both sides. Five common scenarios are analyzed and studied: one car on the passing lane, one bus on the passing lane, two opposing driving automobiles on the passing lane, one car on the fast main lane, and one bus on the fast main lane. The findings of this study revealed that power production from car wakes in the passing lane can be done successfully, with the greatest average power coefficient corresponding to a power of 139.60W. Bani-Hani *et al.*, (2018) presented an experimental investigation of employing a three-bladed helical VAWT specifically developed for producing electrical energy from moving automobiles' wind energy for illumination applications such as highway lights, traffic signals, and light guidelines on highways. According to the results, the VAWT prototype produced up to 48 Watts of power from vehicles moving on the highway at an average wind speed of 4.4 m/s.

The objective of this study is to develop and manufacture a VAWT for use on Sri Lankan expressways. In Sri Lanka, this approach has yet to be adopted. If this approach is effectively applied in an expressway, the generated energy may be utilized to lighten the expressway without relying on non-renewable energy sources.

## 2. METHODOLOGY

### 2.1. Working Principle

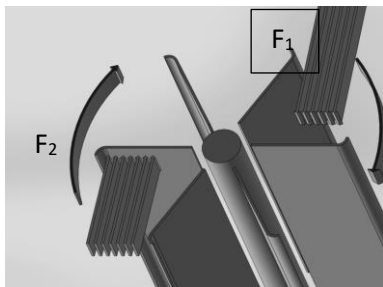

Figure 1: Blade rotating direction

Figure 1 depicts a savonius wind turbine with F1 and F2 sections. The wind strikes and gets trapped in the F1 portion, exerting pressure on the F1 part of the blade, causing a pressure difference between the F1 and F2 sections from upstream to downstream, causing the turbine to spin around its central axis shaft. The wind turbine is located in the divider of the highway. The pressurized air (air pressed from vehicles moving on both sides) is available at the divider. The blade of the vertical axis wind turbine is linked to the main shaft, which has a gear wheel system at the bottom. The generator is connected to a 1:7 ratio gear wheel system.

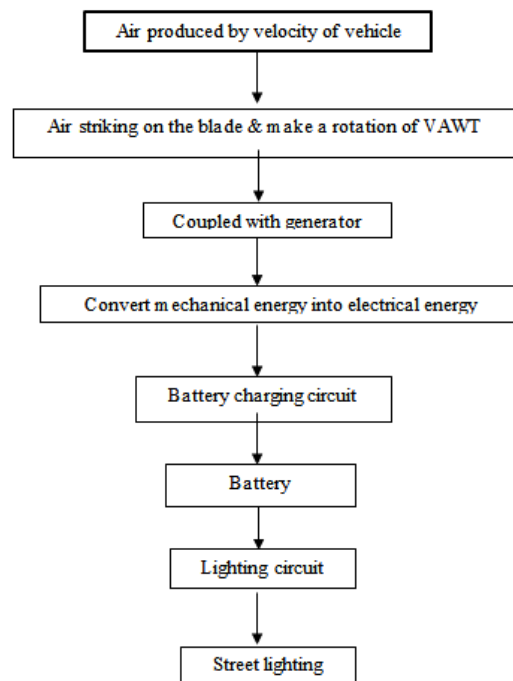

Figure 2: Methodology flow chart

The generator begins to generate A/C electricity when the wind turbine begins to rotate. The A/C power was then converted to D/C power using a three-phase to dc converter circuit. The battery may be charged using the converted D/C electricity.

Figure 2 illustrates the flow chart of the generation of electricity from VAWT. This shows how the electricity is generated, step by step and how it is used in street lighting.

**2.2. Fabrication of Parts**

Fabrication of vertical axis wind turbines (Savonius type) entails a variety of components that must be produced as part of the main assembly. Those parts of VAWT to be fabricated are listed in Table 1 below.

<b>Table 1: Parts of the VAWT</b>	
<b>Part</b>	<b>Description</b>
<b>Base</b>	The base is made of 132 cm height and 66 cm wide with 1.2mm thickness steel box bars. It is designed to reduce the vibrations of the turbine due to turbulent winds.
<b>Blades</b>	Aluminum is used as turbine blades. The blades are 1.2mm thick. Six blades of equal length 100 cm and width of 35 cm were used. These blades are attached perpendicular to the rotor.
<b>Main Shaft</b>	The main shaft was designed to minimize vibration and noise. Optimum efficiency can be achieved when the vibrations are kept to a minimum. The rod is fitted to the shaft with two bearings with nylon bushings on two corners of the shaft.
<b>Generator</b>	12V / 24V Three-phase generator was used to generate A/C power.
<b>Gear wheels</b>	The gear mechanism is used to transmit the power from the turbine to the generator. The gear ratio of 7:1 is used.
<b>Bearings</b>	Bearings support for rotating shaft and constrain relative motion and reduce friction between moving parts.

**2.3. Design and Simulation**

A simulation was conducted using solidwork to compare the various designs of turbine blades. The simulation was carried out based on the computation of velocity at 20 m/s and air pressure and velocity at different axes, blades, and pressure. Figure 3 shows the various designs used in the simulation study.

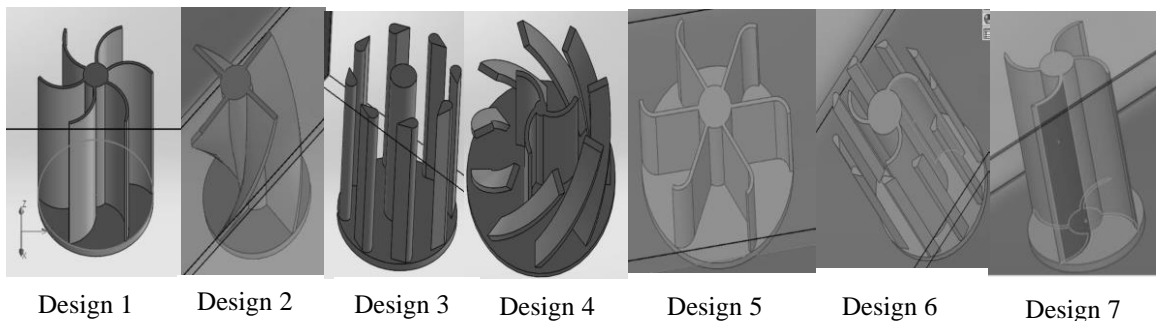

Figure 3: VAWT designs used in simulation

Table 2 shows the summary of the results of the simulation study, and Figure Figure 4 shows the design selected based on the results of the simulation.

**Table 2: Summary of the simulation results**

	Max velocity	GG Force	GG Max Total Pressure
<b>Design no 01</b>	49m/s	10.64N	103746.17Pa
<b>Design no 02</b>	37m/s	4.79N	102513.4Pa
<b>Design no 03</b>	36m/s	4.93N	102650.24Pa
<b>Design no 04</b>	34m/s	2.89N	102739.17Pa
<b>Design no 05</b>	44.399	8.675N	102101.49Pa
<b>Design no 06</b>	35m/s	3.69N	102802.31Pa
<b>Design no 07</b>	38m/s	4.863N	102657.12Pa

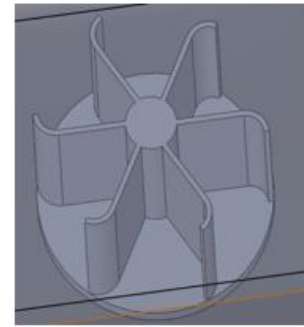

Figure 4: Selected design

When all designs are considered with the parameters concerned, design 01 and design 05 are the most suitable designs. However, when comparing design 1 and design 5 in terms of production difficulties, design 5 was considered to be better. Figure 5 shows the complete design of the VAWT.



Figure 5: Complete design of the VAWT

### 2.4. Power Calculation

In order to calculate wind turbine power, it is first necessary to estimate available wind power and the efficiency of wind power. Before finding the wind power, the swept area of the turbine was determined by using the following equation.

$$\begin{aligned}
 A &= D * H && \text{(Eq: 01)} \\
 &= 53\text{cm} * 60 \text{ cm} \\
 &= 3180 \text{ cm}^2
 \end{aligned}$$

Where, A = Swept area                      D = Diameter of turbine                      H = Height of turbine

After that the available wind power was calculated as shown below.

$$P_{\text{wind}} = 0.5 * \rho * v^3 * A \tag{Eq: 02}$$

P wind = Available wind power                      ρ = Air density

V<sup>3</sup> = Wind speed                      A = Swept area

For wind speed,  $V$ , it was assumed  $65 \text{ kmh}^{-1}$  as the average speed of vehicle moving in the selected testing area (Colombo – Horana highway, Kahathuduwa, Sri Lanka). (It is assumed that the vehicle moving speed as wind speed because the pressurized air is used from moving vehicle) ( $1 \text{ km/h}$  is equal to  $0.277 \text{ m/s}$ ).

$$\begin{aligned} V &= 65 \text{ kmh}^{-1} \\ &= 18.005 \text{ m/s} \\ &= 18.005 \text{ ms}^{-1} \end{aligned}$$

$$\begin{aligned} A &= \text{swept area} \\ &= 3180 \text{ cm}^2 \\ &= 0.318 \text{ m}^3 \\ &= 1.225 \text{ kg/m}^3 \end{aligned}$$

$$\begin{aligned} \mathbf{P \text{ wind}} &= \mathbf{0.5 * \rho * v^3 * A} \\ &= 0.5 * 1.225 \text{ kg/m}^3 * (18.005 \text{ ms}^{-1})^3 * 0.318 \text{ m}^3 \\ &= 1136.87 \text{ kg/s} \\ &= 1136.87 \text{ Ns} \end{aligned}$$

### 3. RESULTS

#### 3.1. Power Generation Testing

The developed VAWT was tested at Kahathuduwa area of Colombo-Horana highway. In the testing process the RPM of the turbine and voltage from the generator were observed. Table 3 presents some results of the testing process.

Table 3: Some testing results of VAWT

R.P.M of wind turbine	R.P.M of the generator	Voltage from generator	Current from generator
25	175	3V	0.3A
50	350	9V	0.8A
70	490	15V	1.1A

Table 3 shows R.P.M of the generator, voltage from generator and current from the generator. The results show how the outputs are varying with respect to the R.P.M. These results indicate that once properly implemented on an expressway, the desired outcomes can be achieved.

#### 3.2 Vibration Testing

Vibration and noises were tested when the turbine is rotating on the road divider. It was observed that there are no vibrations or noises because the rod is fixed to the frame with bearings, and the rod is placed in the main shaft. The bearings are fitted between shaft and rod with nylon bush. The design of the main shaft is therefore a success.

### 4. CONCLUSIONS

Wind forces from moving vehicles are unproductive unless they are utilized for something else. As a result, it would be advantageous if a method could be created to properly and efficiently use wasted air.



One possibility is to produce power from wind generated by moving vehicles. Thus, this study focused to develop and build a Vertical Axis Wind Turbine (VAWT) to produce electricity from wind generated by moving vehicles. The product was tested on a main highway rather than an expressway, and the results were good. Those findings led to the prediction that, once applied on an expressway, the desired outcomes would be achieved. It is ecologically beneficial because the electricity is generated by wind power. Furthermore, this is a cost-effective method of converting kinetic energy into mechanical power, which is subsequently converted into electricity. In Sri Lanka, this system has yet to be implemented. If this technology is refined and applied further, the usage of electricity generated from nonrenewable energy sources may be decreased, which would eventually assist to reduce the environmental pollution.

## REFERENCES

- Bani-Hani, E.H., Sedaghat, A., AL-Shemmary, et al. (2018). Feasibility of highway energy harvesting using a vertical axis wind turbine. *Energy Engineering*, 115(2), pp.61-74.
- Bhutta, M. M. A., Hayat, N., Farooq, A. U. et al. (2012) 'Vertical axis wind turbine - A review of various configurations and design techniques', *Renewable and Sustainable Energy Reviews*, 16(4), pp. 1926–1939.
- Chapman, P. and Wiczowski, P., (2009). Wind-Powered Electrical Systems-Highway Rest Areas, Weigh Stations, and Team Section Buildings. Urbana: Illinois Center for Transportation.
- Johari, M.K., Jalil, M. and Shariff, M.F.M., (2018). Comparison of horizontal axis wind turbine (HAWT) and vertical axis wind turbine (VAWT). *International Journal of Engineering and Technology*, 7(4.13), pp.74-80.
- Kulkarni, S.A. and Birajdar, M.R., (2016). Vertical Axis Wind Turbine for Highway Application. *Imperial Journal of Interdisciplinary Research*, 2(10). pp. 1–5
- Tian, W., Mao, Z., An, X. et al. (2017). Numerical study of energy recovery from the wakes of moving vehicles on highways by using a vertical axis wind turbine. *Energy*, 141, pp.715-728.
- Zheng, H., Song, M. and Shen, Z. (2021) 'The evolution of renewable energy and its impact on carbon reduction in China', *Energy*, 237, p. 121639.

# Design and Fabrication of Multi-Functional Pipe Fitting Tool

K. G. Alahapperuma\*, T. R. Paranamanaana, K. T. D. Kalansooriya, I. G. P. Darshana  
Gunarathna

Department of Mechanical and Manufacturing Technology, University of Vocational Technology, Sri Lanka

## ABSTRACT

*The advancement in the plumbing industry has transformed its simple operations into more complex operations, resulting in different equipment for each function. However, a collection of tools is required to complete a plumbing process. The objective of this study was to develop a single tool that would simplify the complexity of plumbing tasks. The designed tool consisted of three pieces with specialized functions for each. The main tool material was mild steel, while the middle piece possessed a nylon cover and the tool handle. The front and back pieces had three and two parts, respectively. The layout of the tool was constructed by SOLIDWORKS software, and fabrication was performed by a Computer Numerical Control (CNC) machine and a lathe machine. The tool was tested for functionality using two brands of Polyvinyl Chloride (PVC) pipes of different sizes. Statistical analysis was performed with the Analysis of Variance (ANOVA) test using Minitab software. The product proved to be an easy-to-use, portable and multi-purpose tool that can perform essential functions of cutting, heating, and burr removing operations of PVC pipes.*

**Keywords:** Multi-Purpose Plumbing Tool; Plumbing; Polyvinyl Chloride Pipes.

## 1. INTRODUCTION

Most of the modern buildings essentially consist of a plumbing system for the transportation of water for different human needs, such as day to day uses and different industrial operations. Plumbing systems carry other liquids, such as a variety of oil types. However, most of the plumbing systems are based on domestic water transportation. Most of the utility pipe systems consist of PVC usually soldered or glued. These systems have features such as safety, durability, cost effectiveness, environmental efficiency, and recycling capability, etc.

General operations in a plumbing system include cutting, heating, burr removal operations, and joining, etc. Among them, cutting, heating, and burr removing operations are major, which essentially need the support of another tool. For these three operations, conventional procedures are still used today, especially when connecting or repairing pipes in domestic use. Almost all automated or semi-automated modern plumbing aid tools are based on cutting operations only. Other main operations such as heating, burr removing, etc. are still done with manual and conventional techniques.

If a single device is available for all major plumbing operations, it will simplify the plumbing task, and minimize the number of parts inside the plumber's luggage.

## 2. LITERATURE REVIEW

The history of plumbing tools dates back to ancient Rome. In these early days, many cities were plagued by epidemics and diseases caused by the quality of drinking water or by dumping dirty water on the streets. Therefore, the first plumbing fixtures were designed to bring clean water to public bathrooms and maintain drainage systems that remove wastewater.

PVC became a popular plumbing material in the 20th century due to its durability, ease of installation, and low cost. PVC pipes are superior to metal for water and drain pipes because they do not rust or corrode. Due to the durable nature of PVC pipes, many of the original pipes installed in 1936 are still functional, and they have become a common choice for residential plumbing systems.

---

\* Corresponding Author: E-mail - [gayanthi111@yahoo.com](mailto:gayanthi111@yahoo.com)

Among the various tools and equipment used for plumbing, different cutting machines and tools have been given major consideration. Among them, Thorat (n.d.) has developed a special machine that can cut different shapes of objects such as circular, rectangular and polygonal shapes. Depending on the type of material being cut, the cutting tool can be changed, and the machine can be used in almost all types of cutting operations.

Generally, cutting machines are manually operated for medium and small-scale industries. A new machine produced can be used to feed and cut PVC pipes automatically. This machine could be used for several pieces with different lengths to be cut simultaneously. Another machine created by Vaibhav could be used to cut pipes to the desired length with minimal waste generated around the pipe. An automatic machine developed by Thandolwenkosi also aids in the plumbing sector by the reduction of total time required for the entire cutting process of PVC pipes.

Although multiple essential operations are to be performed during the plumbing process, only cutting tools with different capacities have been developed. The burr removing operation is performed with any other sharp tool, such as a knife, while the heating operation is performed with a flame, which may not result in a uniform heat. So far, no studies are found in literature on multifunctional plumbing tools.

The study aimed to design and develop a multi-functional plumbing tool for PVC pipe systems. With the findings of the project, such processes as developing pipe systems, replacing and maintaining pipelines are expected to perform more efficiently and easily than the current practices.

### 3. METHODOLOGY

#### 3.1 Project Design

The main components of the project design are given in the figure 1.

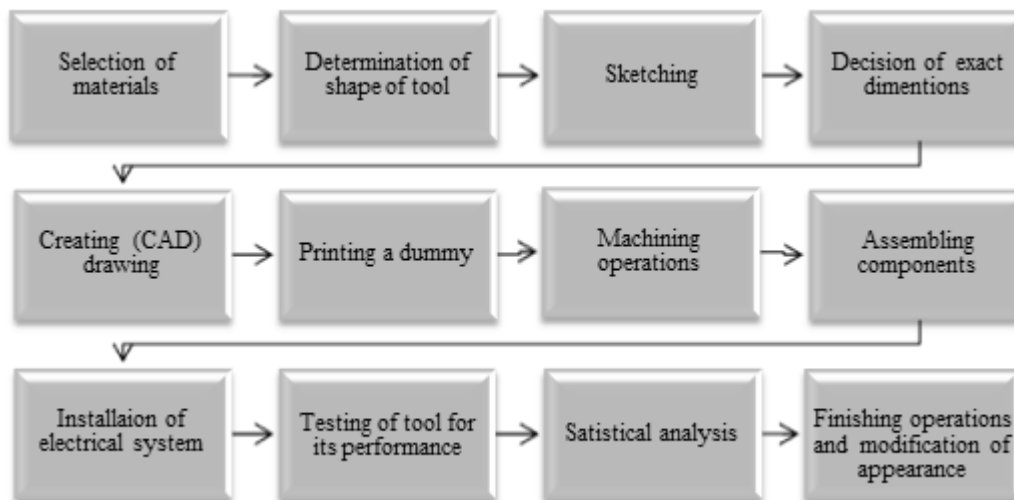

Figure 1: Flow Chart of the Project

#### 3.2 Main Steps

A rough sketch of the tool is shown in figure 2. The idea of sketching is to identify problems and suitable improvements for the design. A rough sketch with approximate dimensions helps to redesign a good sketch with correct measurements.

According to the design, the length can be changed according to the torque required to tighten the nut in the jaw. The surface of the jaws is designed to fit well with the pipe component, being worked. The width of tool jaws can be adjusted as required, while remaining parallel to each other. The adjustment is done by using a screw and slide mechanism that pushes one jaw towards another.



Figure 2: Sketch of the Tool

According to the designed dimensions, a drawing was created using SOLIDWORKS and Microsoft Project. Hardness, durability, and operating possibilities were tested with the use of SOLIDWORKS software. Design features of the tool with respect to main operations are shown in the figure 2.

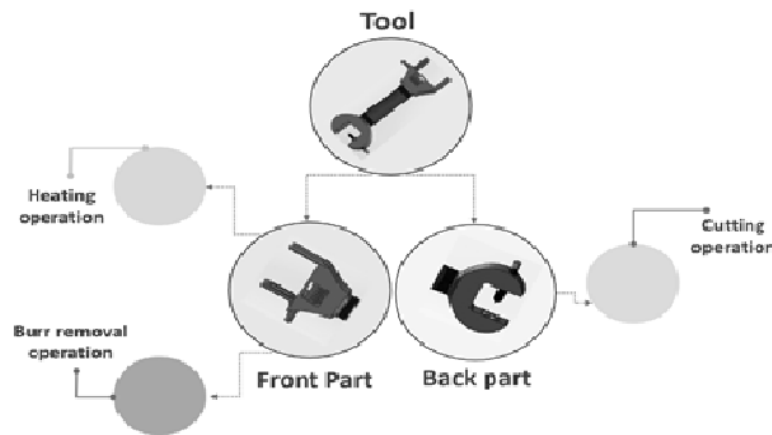

Figure 3: Main Operations done by Each Part of the Tool

Cutting of PVC pipes is performed by the tool bit fixed through the hole in one of the two jaws at the back side of the tool. After the pipe is mounted inside the jaws, it is rotated manually, while it is being cut by the tool bit. The rotating of the mounted pipe is facilitated by the two wheels mounted on the other jaw on the same side. The heating operation is performed by one edge of the front side of the tool, with an electrical power supply, given by the main source. Electrical wires are installed in the tool through a commercially available insulating material (MgO powder), and the connecting switch is mounted on the tool handle. The other edge of the front side of the tool has been sharpened by a file, enabling burr removing operation of PVC pipes.

There were two main machining operations in this system; a CNC machining operation and a lathe machining operation. According to the drawing, there were 10 parts to be built, and each part was cut, separately. Ten parts of the tool include four parts on the front side, middle part, and five parts on the back. Four parts of the front consist stable part, a moving part, an adjustable wheel (with an 18 mm diameter to control the moving part), and a nut used to connect the adjustable wheel to the stable part, while five parts of the back consist of two wheels (each with a 3 mm diameter), two nuts with similar dimensions (2 mm diameter) to connect the two wheels, and a tool bit (M8 size) used for cutting operation.

Initially, all parts were cut separately, by CNC machine. The external shape of the components was given by the CNC machine, and lathe cutting was followed. A lathe machine could cut certain sections that a CNC machine couldn't. Required milling, grinding, drilling, tapering and taping operations were followed, as required for each component.

After machining operations, the parts of the tool were assembled according to the CAD drawing. The front part and the back part were attached to the middle part. All three parts are made with threads to make it easier for assembling.

After assembly, an electricity supply point is installed in the tool handle, and the electricity is delivered through it to the front side of the tool to be used for heating operations.

The tool was repetitively tested for its performance, using pipes of two commercial brands, for cutting, heating and burr removing operations. Average periods consumed by the tool and by the conventional method for each operation were noted and the difference was compared. Cutting with a hack saw, heating with a fire flame, and burr removing operations with sand paper (waterproof silicon carbide-166) were the adapted conventional methods. The test was performed under the same environmental conditions. The tested pipes were of 1-inch standard size, and ten readings were obtained for each operation, representing five readings for each brand. All ten readings of each test were averaged to express the final reading.

Additionally, an ANOVA test was conducted three times using MINITAB 16 software, for three pipe sizes, for the three operations conducted by the tool, to observe whether there is a significant difference between the time spent, in between different pipe sizes, for each operation. Ten readings were obtained for each operation, for each pipe size, representing five readings for each brand.

Finishing operations such as modification of shape, sharpening edges, polishing the surface, and producing a cover box etc. were done as final steps of the project.

#### 4. RESULTS AND DISCUSSION

##### 4.1 Results

The final output of the tool is shown in figure 4.

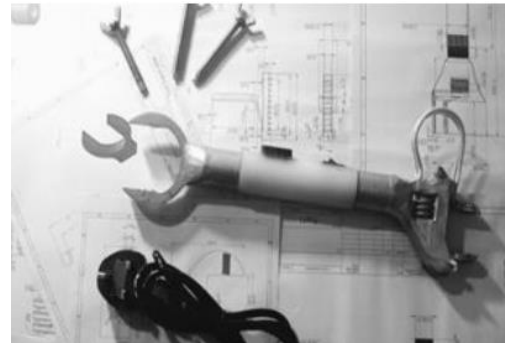

Figure 4: Final Output of the Tool

Figure 5 shows the average time periods consumed by each conventional method and the time periods consumed by the tool for the main operations of cutting, heating and burr removing of the plumbing process, for 1-inch standard pipe size.

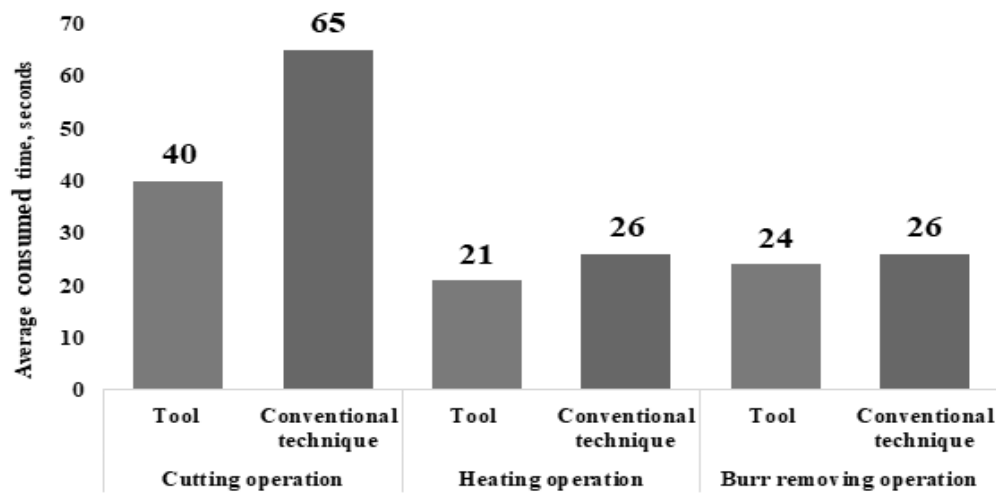

Figure 5: Comparison of Average Time Periods Consumed by the Tool and by the Conventional Techniques for Three Main Operations

According to the figure 5, the tool consumed less time for two tasks than for conventional techniques. The average time periods consumed for cutting operations by the tool and by the conventional technique were 40 and 65 seconds, respectively. Moreover, the average time periods consumed for the heating operation by the tool and by the conventional technique were 21 and 26 seconds, respectively and the time periods consumed for the burr removing operation by the tool and by the conventional technique were 24 and 26 seconds respectively. There is no observable difference between the readings of the two brands.

It is obvious that the best performance of the tool relative to the conventional technique is for cutting operations, and the percentage time reduction for the same was 38.4%. In addition, the tool shows a 19.23% and a 07.69%-time reduction compared to conventional methods, for heating and burr removing operations, respectively.

According to the ANOVA test results, the obtained probability (p) value in each case, conducted for each operation, is almost zero, implying a significant difference in the periods spent for each operation with the tool, in between the pipe sizes.

#### **4.2. Discussion**

The main objective of the study was to design and develop a plumbing tool that could perform the main operations of cutting, heating, and burr removing of PVC pipes, which was clearly achieved. With respect to cutting and heating operations, the tool also shows an observable improvement, compared to conventional techniques.

Additionally, uniform heating of the required pipe surfaces can be obtained with this tool, which is impossible with conventional flame heating. The tool can be used for PVC pipes of different standard sizes of  $\frac{1}{2}$ ,  $\frac{3}{4}$ , 1,  $1\frac{1}{2}$  and 2 inches.

Even though burr removing with the tool shows a time reduction compared to the conventional method of rubbing with a sand paper, it doesn't give a noticeable improvement. Proper shaping the edge of the tool used for burr removing couldn't be performed due to practical limitations.

The tool still shows certain limitations. The product works with direct current, which has 230 voltages. Wire code and the tool come with waterproof materials and fireguard technology. However, it is dangerous to use the tool in places in contact with water, and with water pipes. If a rechargeable battery is going to be inserted, it may cause the tool to be heavier for a single person to carry, easily. Apart from that, the usage of direct current comparatively ensures a uniform and continuous power supply. Anyway, usage of wired technology is a somewhat limited part of this tool.

Since mild steel is the main material used, the tool may get corroded easily if exposed to an aqueous or any other corrosive environment. Even though the equipment is coated with a paint layer, the coating on front side ends was detached due to the rubbing action of those surfaces with the working pipes.

Since the main tool material is mild steel, the tool is approximately 0.95 kg in weight, with which it is not easy for an average person to carry it easily with a single hand for a sufficient duration, till the end of a plumbing process.

In contemporary technology, all the devices and equipment are made to ease the work of people. With the updated technology, portability can be taken as one area of improvement. This tool doesn't have a reasonable probability during heating operation since it works with wired technology. Anyone who uses this tool can carry it only up to the length of the wire.

It is impossible to use the tool, if the user wants to work with pipes larger than the standard 2-inch size. Even with these limitations, the equipment consumes fewer time periods for all three operations, compared to the conventional methods. Apart from that, the tool is a straightforward and portable device, which causes little damage to pipes.

## 5. CONCLUSIONS

The study was a success by achieving its objective of developing a multifunctional tool for the plumbing process, in a user-friendly and cost-effective manner. This single tool can be used to perform three main operations involved with PVC pipelines, for which other devices aren't found. Additionally, the tool displays better performance for all three operations of cutting, heating and burr removing than the conventional techniques employed in domestic pipelines.

The susceptibility of the tool material to corroding and thereby reducing the efficiency of cutting and burr removing operations, risky use in places in contact with water, higher weight due to mild steel tool material for a single person to carry for a sufficient duration, limited portability with wired technology, and the inability to work with PVC pipes larger than the 2-inch diameter standard size are the limitations of the development.

Future developments of the study should pay attention to lightweight, non-corrosive tool materials. The jaw size of the tool should be made larger to enable larger size pipes to also be worked with. Since application of glue is also one essential operation practiced manually when joining PVC pipes, future plumbing tools' applicability to this performance should be considered.

## REFERENCES

- Davison Design, 2012. 'The history of plumbing tools', *Davison Design*, viewed 14 February 2021, <https://davison-design.blogspot.com/2012/09/the-history-of-plumbing-tools.html> .
- 2021, *Why PVC pipes*, PVC4Pipes, viewed 16 June 2021, <https://pvc4pipes.com/pvc-pipes/why-pvc-pipes/> .
- 2012, *PVC piping systems for commercial and industrial applications*, Plastic pipe and fittings association, Glen Ellyn, viewed 11 February 2021, <https://docplayer.net/13368261-Pvc-piping-systems-for-commercial-and-industrial-applications.html> .
- Creative Mechanisms, 2016, *Everything you need to know about PVC plastic*, blog, viewed 10 February 2021, <https://www.creativemechanisms.com/blog/everything-you-need-to-know-about-pvc-plastic> .
- Mohan, M., Sathish, M, Prakash, R., Kalil Rahiman, M., 2019. 'Design and fabrication of automatic PVC pipe feed and cutting machine', *International Research Journal of Engineering and Technology*, viewed 16 February 2021,
- Vaibhav, k., Prasad, M. K., Prasad, D. D, Gowthami, K., 2020. 'Design and fabrication of PVC pipe feeding and cutting machine', *International Research Journal of Engineering and Technology*, viewed 13 February 2021,
- Thandolwenkosi, E. and Mushiri, T., 2018, *Design of an automated poly-vinyl chloride (PVC) pipe cutting machine*, International Conference on Industrial Engineering and Operations Management, viewed 8 April 2021,
- 2021, *Lonestar College*, Energy, Manufacturing & Construction, viewed 17 June 2021, <http://www.lonestar.edu/departments/curriculuminstruction/PipeFittingNCCER.pdf> .
- Thorat. S., Learn Mechanical Engineering, Pune, Maharashtra., viewed 15 February 2021, <https://learnmech.com/design-and-fabrication-of-typical-pipe-cutting-machine/>

## Factory Observer Pneumatic Hybrid Vehicle

T.D.C.S Abeywickrama<sup>1</sup>, B.M.I.M.B Bulathge<sup>1</sup>, A.A Thilina Lakmal<sup>1</sup>, U.M.R.B Ulpenge<sup>1</sup>,  
Dilshan Ganegoda<sup>2\*</sup>

<sup>1</sup>Department of Mechanical and Manufacturing Technology, University of Vocational Technology, Sri Lanka

<sup>2</sup>Department of Electrical and Electronics Technology, University of Vocational Technology, Sri Lanka

### ABSTRACT

*The main objective of this project was to produce a small car that could be easily driven in factories using pneumatic and hybrid technology while minimizing pollution (guide vehicle). This project aimed at producing a vehicle that could travel in a factory to minimize environmental pollution. In this project, a pneumatic system and an electrical system were used to generate the mechanical energy required to drive the vehicle. Accordingly, the pneumatic system receives the required power by supplying the compressed air in the cylinder to a pneumatic motor. The electrical system is powered by a battery for a DC motor. After the vehicle leaves the electric motor at a speed of 14.4 km per hour from the start, the electric motor is deactivated and powered by the pneumatic motor. Once the power of the pneumatic system is reduced, power is supplied to the electric motor.*

**Keywords:** Electric Power, Hybrid Vehicle, Pneumatic, Pressure.

### 1. INTRODUCTION

In today's society, transportation depends on vehicles. Pollution has increased due to the reliance on automotive fuels. Transportation is not based on highways but is now used inside factories. The main objective of this research is to produce a small car that can move easily in the factories using pneumatic and hybrid technology while minimizing pollution (guide vehicle). It is very difficult to move from one part to another in an emergency in a large factory, and it takes a lot of time. This car uses an electric motor and a pneumatic motor to achieve rotational motion. After we reach a speed of 14.4km / h from the start of the vehicle by the electric motor, the electric motor is turned off and powered by the pneumatic motor. After the power in the pneumatic system is reduced, power is restored to the electric motor. The reasons we use this vehicle in the factory are the fact that we do not need to travel at high speeds in the factory, we operate this vehicle only in the area where the compressed airline of the factory is located and the fact that there are no mountains where it is difficult to travel in the factory affects the limits of our research.

The main objective of this project is to produce a small car that can be easily driven in factories using pneumatic and hybrid technology while minimizing pollution (guide vehicle). The best solution currently on the market is EV(Electric Vehicle).This is due to the lower carbon emissions of EVand the lower cost of running. But the downsides of the EV are that its battery life is shorter and I was able to run shorter distances. But we are testing to increase battery life and drive longer than EV. This is how the power of the electric system of our vehicle is transferred to the pneumatic system so that the battery of the vehicle can be minimized. This allows us to

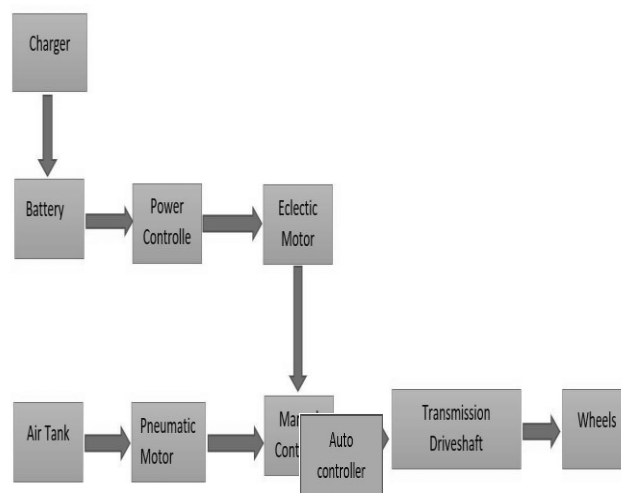

Figure 10: Block diagram

\* Corresponding Author: E-mail - [ganegodadilsh@gmail.com](mailto:ganegodadilsh@gmail.com)



get the most out of the battery and we can drive our vehicle farther than EV. Our vehicle emits less carbon.

The environment if recycling processes will continue to function in the current way. To this aim, by considering scientific works published from 2000 up to 2019. Results show that the experts have paid great attention to this topic, given both the critical and valuable materials embedded in EVs and their main components (especially traction batteries), by offering interesting potential profits, and identifying the most promising End-of-Life (EoL) strategy for recycling both in technological and environmental terms. However, the economics of EV recycling systems have not yet been well quantified. The cost of replacing a battery is high because the battery life of electric vehicles is rapidly reduced. Also, the more batteries discharged into the environment, the more pollution there is. We hope to extend the life of the electric battery here.

The remainder of this work is organized as follows: in section 2, the methodology of the research work, fabrications and system design with the simulation model. In section 3, results and discussion of the system model. Finally, section 4 concludes and recommendations.

## 2. METHODOLOGY

### 2.1 Working Principle

The rear wheels of this vehicle are powered by an electric motor and a pneumatic motor. The compressed air required for the pneumatic system is stored in a 100l tank. The air piping system in the factory is used to compress the air. The power required for the electric motor is provided by charging a battery. The main power of the expansion comes from Pneumatic power and an electric motor. Air is used for the Pneumatic system. This is environmentally friendly. The vehicle can start moving. As the energy stored in the tank decreases, the electric motor activates and powers the rear wheels.

#### 2.1.2 Electrical System

The starting rotation of our vehicle is done by the Electrical system and as soon as the vehicle starts running at a uniform motion (14km/h) the Electrical system will turn off and the pneumatic system will be activated. Power is transferred back to the electrical system as the vehicle slows down. To control this we use by programming an MICROCONTROLLER(Arduino). This requires the use of a speed sensor to detect the speed of the vehicle. Also, pneumatic electrical valve, Electrical motor controller have to be used.

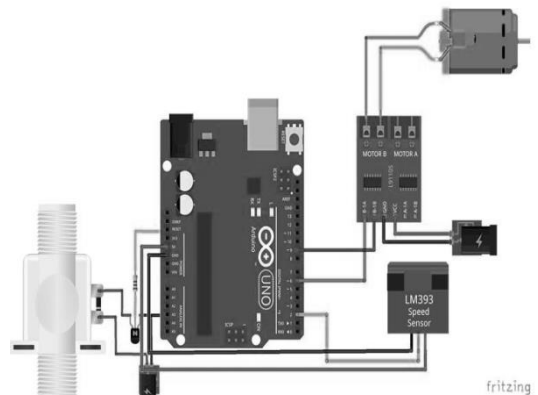

#### 2.1.1 Mechanical System

Our vehicle has 2 power systems. It is electric and pneumatic. The rotational power from the electric motor and the air motor is transmitted to the wheels by a chain.

- 1 Air Motor: - This pneumatic motor produces the kinetic energy required for our vehicle. Details of the pneumatic motor we use. 5.25 HP Gast 8 AM-FRV-2B rotary vane pneumatic motor is used. It has a maximum speed of 2500 rpm. The maximum operating pressure is 7 bar. Maximum torque used is 21 N-m. Air consumption is 175 cm and the corresponding pneumatic motor.

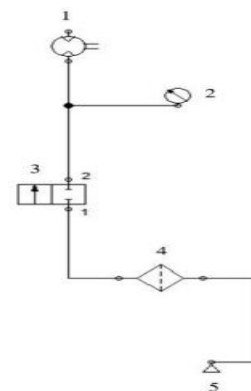

Figure 3: Pneumatic Circuit Diagram

- 2 Presser meter: - We have to use a compressor to compress the air into the cylinder. 3
- 3 Electro pneumatic valve: - Giving an electrical signal to this valve releases air to the desired pressure.
- 4 Air service unit: - This is used to remove dust particles, moisture, etc. in the air we compress.
- 5 compressed air supply: - The air for our project is sourced from the factory air pressure system. We use an air pressure tank to store this air.

For this, we use a carbon steel tank. The reason for that are;

- It has the highest rigidity and toughness of carbon steels
- Low ductility.
- High carbon steel is actually a wear resistant material
- That they are almost always hard and soft.

Details of the tank we use are as follows.

- Size: 800mm \* 400mm\* 932mm
- Net Weight: 30
- Thickness: 3mm
- Volume: 100L
- Pressure:150 bar 1.25MPA (12KG)

## 2.2. Resistance Types

There are four resistance types in our vehicle as; rolling resistance, acceleration resistance, grading resistance and aerodynamic drag.

Gradient resistance and aerodynamic drag resistances do not affect our vehicle. Our vehicle does not run fast because it is driven in a factory. Grading resistance is not affected as it is not run on hilly terrain.

### 2.2.1 Rolling Resistance

Vehicle weight + Human Weight = 200Kg /Pneumatic motor torque = 21Nm Wheel radius = 20cm

The weight of the vehicle will be equally divided into front wheels and rear wheels.

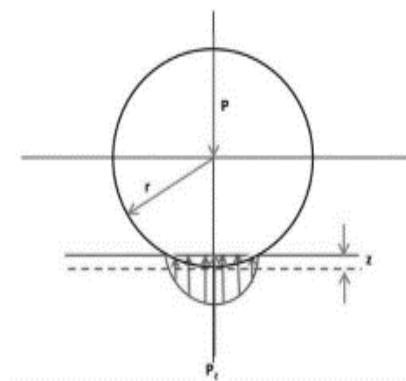

Figure 4: Rolling resistance

$$\text{Total rolling resistance} = \mu(RF+RR) \quad (\text{Eq: 01})$$

where,

$$\text{Front rolling resistance} = \mu RF$$

$$\text{Rear rolling resistance} = \mu RR$$

$$(FFR) = \mu Mg$$

$$P(Mg) = \text{Normal load acting on the rear rolling wheel (N)}$$

$\mu$  = rolling resistance coefficient  
 $Mg = 200 \times 9.8 \text{ N}$  RR RF a a  $Mg/2$   $Mg$   $Mg/2$  19  
 $\mu = 0.011$  (Rolling resistance is concrete road)  
 Total rolling resistance =  $\mu Mg$  (FFR) =  $0.011 \times 200 \times 9.8 = 21.56 \text{ N}$

**2.2.2 Acceleration Resistance for Wheels**

$$F_a = \lambda M * dv/dt \tag{Eq: 02}$$

where,

$\lambda$  = Rotational coefficient (0.1)  
 $M$  = Mass of the vehicle with passengers (200kg)  
 $a$  = Acceleration of the vehicle (0.4ms<sup>-2</sup>)  
 $F_a = \lambda M * dv/dt$   
 $F_a = 0.1 * 200 * 0.4$   
 $= 8 \text{ N}$

**2.2.3. Total Driving Resistance**

$$F_{AR} = \mu (RF + RR) + \lambda * M * a \tag{Eq: 03}$$

where,

Total resistance on the vehicle = FAR

Total rolling resistance =  $\mu (RF + RR)$

Acceleration resistance =  $\lambda * M * a$

$$\begin{aligned} F_{AR} &= \mu (RF + RR) + \lambda * M * a \\ F_{AR} &= \mu Mg + \lambda * M * a \\ &= 21.56 \text{ N} + 8 \text{ N} \\ &= 29.56 \text{ N} \end{aligned}$$

$$Ma = FT - (\mu * Mg + \lambda Ma) \tag{Eq: 04}$$

where,

Force received to accelerate = Ma

Tractive Force = FT

Total resistance on the vehicle the vehicle =  $(\mu * Mg + \lambda Ma)$

$$F_T = Ma + (\mu * Mg + \lambda Ma)$$

$F_T$  = (Tractive force required at the tires to accelerate (a) the vehicle.)

**2.2.4. Find the Torque**

$r_w$  = Wheel rading

$T_M$  = Motor torque

$$T_M = F_T * r_w$$

So,

$$T_M = [Ma + (\mu * Mg + \lambda Ma)] r_w \tag{Eq: 05}$$

where,

$\mu$  = Rolling resistance coefficient  
 $M$  = Mass of the vehicle with passengers (kg)  
 $g$  = accelerate to gravity (ms<sup>-2</sup>)  
 $\lambda$  = Rotational coefficient  
 $a$  = Acceleration of the vehicle (ms<sup>-2</sup>)

$r_w$  = Wheel radius(m)

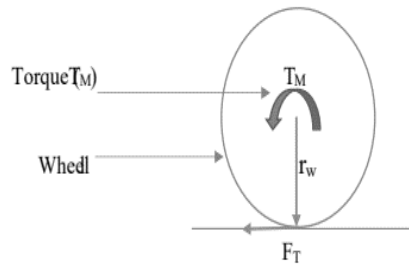

Figure 5: Find the torque

So, we can now calculate how much torque is required by the motor to 0.4ms<sup>-2</sup> speed using this formula.

$$\mu = 0.011 / M = 200\text{kg} / g = 9.8\text{ms}^{-2} / \lambda = 0.1 / a = 0.4 \text{ ms}^{-2} / r_w = 0.2\text{m}$$

$$T_M = [Ma + (\mu * Mg + \lambda Ma)] r_w$$

$$T_M = [(200*0.4) + (0.011*200*9.8) + (0.1*200*0.4)] * 0.2 = 21.91 \text{ Nm}$$

Calculate it need 21.91 Nm torque to go 0.4ms<sup>-2</sup> speed.

$$v = u + at$$

(Eq: 06)

where,

- v= final velocity
- u= initial velocity
- a= acceleration
- t= time

$$\begin{aligned} v &= u + at \\ &= 0 + (0.4 * 10) \\ &= 4\text{m/s} = 14.4\text{Km/h} \end{aligned}$$

### 2.3 Calculation of Rpm

Weight = 200Kg, Efficiency = 85%, Wheel size = 0.2m, length of car = 2400mm, Width = 1000mm, speed = 5kmph,

$$\begin{aligned} \text{Linear Distance Travelled} &= 2\pi r \\ &= 2 * 3.14 * 0.2 \\ &= 1.25\text{m} \end{aligned}$$

$$\begin{aligned} \text{Speed} &= 14.4\text{kmph} = 14400/3600 \\ &= 4\text{m/s} \end{aligned}$$

Find rpm, Rpm = Total Distance Covered Per hour / Linear Distance

$$= 14400 / (1.25 * 60) = 192\text{rpm}$$

The torque required to drive our vehicle is 21Nm, so we have to choose the motor torque which is 21Nm. We are using BLDC motor which is 2.5kw 48v, run at 192rpm because as our calculation shows that the mechanical output torque that need to move vehicle is 21 Nm and the motor provide torque to the wheel is approx.

### 2.4 Design and Simulation (Solid Works)

This is how we disassembled the body and frame required to make this vehicle.

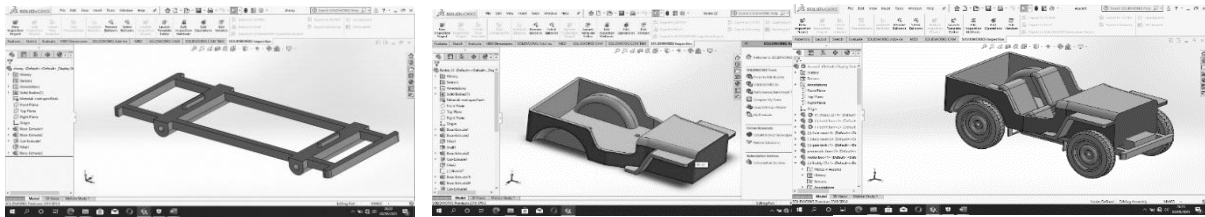

Figure 6: Simulation of frame and body

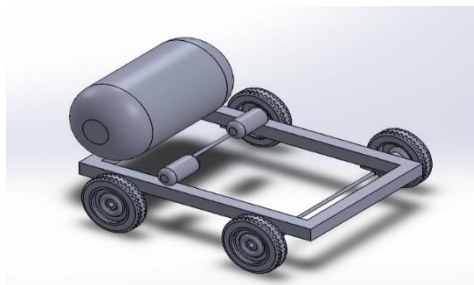

Figure 7: Prototype model

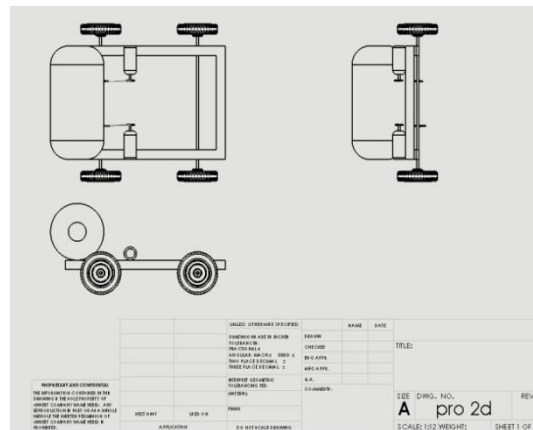

Figure 8: 2D Prototype design

### 3. RESULTS AND DISCUSSION

Our project is to produce a vehicle that can be driven in a factory. However, the devices we used to make the prototype for the test are as follows. The vehicle is powered by a pneumatic and electric system and uses a 10 L cylinder for the air system. The cylinder compresses about 200psi. The cylinder then applies 6 bar of pressure to the air motor. It converts the energy required to drive the vehicle into kinetic energy and powers the rear wheels of the vehicle. The speed of the vehicle is determined by the air pressure applied to the air motor. For the power electrical system, we use a 12 v battery and a 100 rpm motor. In this case the motor takes the required amount of voltage (v) from the battery and rotates the motor. The kinetic energy provided by the motor is given to the rear wheels of the vehicle. It drives the vehicle. The control unit controls the speed of the vehicle.

We were able to build our vehicle while minimizing pollution. Also, the pneumatic system was able to drive the vehicle at the speed we expected. We used to compress the 10L cylinder to around Air 200PSI and then apply the required pressure to the Air impact hammer through a control valve. When the amount of compress air in the cylinder decreased, our compressor was compressed again by a compressor. For the electrical system we used a high torque, 100RPM motor. We used a bicycle battery to power the motor.

#### 3.1 Speed as Weight Increases

The speed of the vehicle is checked by increasing or decreasing the weight of the vehicle when the pressure size given to the pneumatic motor is constant at 6 bar.

Table 17: Speed as weight increases

Weight	Speed
15	1.2m/s
17	0.97m/s
19	0.5m/s

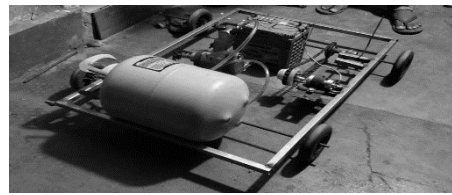

Figure 9: Prototype vehicle

### 3.2 Speed as The Pressure Increases

Keeping the weight (15kg) of the vehicle constant and testing the speed of the vehicle by increasing or decreasing the pressure (bar size) supplied to the pneumatic motor. Instead of an air motor we used a pneumatic impact hammer.

Table 2: Speed as the pressure increases

Pressure(bar)	speed
7	1.5m/s
6	1.2m/s
5	0.9m/s



Figure 10: pneumatic impact hammer

### 3.3 Cylinder Pressure Test

Compressing the air full to the cylinder we are using and testing the time it takes for the pressure in the cylinder to decrease. Time how long and how far the vehicle can travel.

Table 3: Cylinder Pressure test

Bar	Time(s)	Distance(m)
5	32	27
6	28	19
7	13	15



Figure 11: Cylinder

### 3.4 Battery Power Testing

After fully charging the 12 v battery we are using, testing how long it takes to reduce the battery charge and distance testing. We are using a 12V, 4Ah Lead acid battery. This battery is powered by an electric motor after full charge. The vehicle weighs 15kg and runs for about 25 minutes until the battery power is low.

## 4. CONCLUSION AND RECOMMENDATIONS

Our research is to produce a hybrid vehicle that can carry two people in a factory. The two technologies used to hybridize our vehicle are the electrical system and the pneumatic system. The technology we use for the electrical system is to produce the kinetic energy required for our vehicle by recharging an electrical battery and supplying the required power to the motor. The vehicle's starting motion is carried

out by this electrical system. Automatically switches to a pneumatic system once the vehicle is in uniform motion. The technology we use for the pneumatic system here is to activate the pneumatic motor by supplying air to the pneumatic motor under the pressure we need through an air compressed tank. Here the cylinder is recharged using the factory compressed airline.

We hope to develop a system to charge the battery while we are running our vehicle and create a solar charging system in the factory to charge our battery with that solar power. We also hope to create a system to store the exhaust gas in our vehicle's exhaust system in another tank and reuse it.

## REFERENCES

- Barr, A., 2006. *HYBRID VEICLES: MECHANICAL ALTERNATIVES* , Warwick Manufacturing Group (WMG), International Manufacturing Centre (IME), : University of Warwick, .
- Clement Layolam Fernandez, J. A. T. A. S. J. M. I. A. K., 2018. *Fabrication of Pneumatic Four Wheeler*, IJNTR: International Journal of New Technology and Research.
- Franco Antony, S. M. S. D., 2014. *Design and Development of Pneumatic Hybrid Vehicle (PHV)*, Thrissur, India: International Journal of Innovative Research in Science, Engineering and Technology.
- Fuad Un-Noor, S. P. , L. M.-P., 2017. *A Comprehensive Study of Key Electric Vehicle (EV)* , Department of Electrical and Electronics Engineering, University of Johannesburg, Auckland Park : MDPI.
- Idiano D'Adamo, P. R., 2019. *A Structured Literature Review on Obsolete Electric*, Department of Management, Economics, and Industrial Engineering, Politecnico di Milano: MDPI.
- Julio A. Sanguesa, V. T.-S., 2020. *A Review on Electric Vehicles: Technologies and Challenges*, University of Zaragoza, Atarazana: MDPI.
- Maiorescu, P., 2017. *Pneumatic vehical*, University of Tîrgu Mureş, str. Nicolae Iorga, no.1, Tîrgu Mureş, 54008, Romania : ScienceDirect.
- Mr.C.Naveenkumar, M. A. M. R. S., 2018. *Design, Fabrication and Simulation of Compressed Air Hybrid Vehicle*, Department of Mechanical Engineering, S.K.P Engineering College, Tiruvannamalai,: International Research Journal of Engineering and Technology (IRJET).
- Rahul Jeughale, S. R. S. P., 2017. *Design & Fabrication of Automatic Pneumatic Vehicle*, Department of Mechanical Engineering, Anantrao Pawar College of Engineering & : International Research Journal of Engineering and Technology (IRJET).

# Gasified Oil Burner Prototype Development: Potential for Local Industrial, Commercial and Household Applications

S. Sachintha, G.D.T.N Kumarasiri, B.A.V.M Bamunuarachchi, Aruna Warahena\*

Department of Mechanical and Manufacturing Technology, University of Vocational Technology, Sri Lanka

## ABSTRACT

*Thermal energy derived through combustion of fuel has wide varieties of applications in industrial, commercial, and household sectors. The efficient combustion of liquid petroleum and bio fuels for thermal process applications has a significant bearing on energy, environment, and economic aspects. Exploring gasification solution for liquid fuels prior to their combustion would be important, in this regard. This project focused on liquid fuel gasification based burner development to enhance the effective combustion of liquid fuels. The strategic process of oil or liquid fuel turning into gaseous form prior to combustion improves the effectiveness of combustion. A liquid fuel gasification combustion system was developed with basic operational features, as a functional prototype. This first basic prototype seemed to have an efficiency of 90%. In this initial development, the arts associated with combustion experiences became beneficial in the outlining of combustion system solutions.*

**Keywords:** Burner, Combustion, Fuel, Gasification

## 1. INTRODUCTION

### 1.1. Fire

Fire is recognized as one of the four-elements "Earth (Patavi), Water (Aapo), Fire (Thejo), Wind (Waayo)". The balanced Fire and Heat is vital for nature's life and existence. The usage of fire for lighting, warming or heating, and for cooking purposes were the earliest recognized usages or applications discovered [1]. With the technology evolutions and innovations, the processed-coal, bio liquid fuels (oils of different types), and the petroleum liquid fuels, and the gaseous type substances were derived and adopted as direct sources of fire, for industrial, commercial, and household applications [2]. With the science and technology advancements, the technological innovations in "electricity & magnetism, and radioactivity of materials" added further dimension into the evolutions of fire-equivalent sources.

### 1.2. Burning, Fuels, Combustion, Carbon-Dioxide and Emissions

"Burning" is called the general mean of making fire [1]. Burners are designed and made to facilitate the burning, in the industrial, commercial, and even in household applications, where the controlling of fire is essential. The ability to catch fire and burn easily, or in other words the combustibility is varying from substance to substance. The combustible substance which is specifically being utilized for making fire, is called fuels. Most of the commercial types of fuel are hydrocarbons coming as petroleum products. The ignition of fire using petroleum based hydrocarbon fuels and even plant based bio-fuels can be made with the presence of Oxygen (in the air).

For an efficient fire and its sustenance in industrial, commercial, and other applications, optimal proportions of air-fuel mixture, the effective mix of air and fuel, as well as the continuous supply of fuel and air need to be taken place for the assurance of continuous and effective combustion of fuel [3]. Even though the above fulfils the thermal energy needs in the industrial, services, commercial, and household applications, the emissions of Carbon dioxide and other air pollutants are a challenge for the human and environmental health including global warming [3,4]. Therefore, burner applications and technologies significantly bear the Environmental, Social, and Economic responsibilities [4, 5].

---

\* Corresponding Authors: Emails - [aruna.warahena@gmail.com](mailto:aruna.warahena@gmail.com)



## **2. BACKGROUND**

### **2.1. The Arts in Combustion Solutions, other than the Science and Technology**

The arts associated with the creativity, innovation, and problem solving experiences associated with fuels and combustion are quite important, in providing combustion system solutions. The equipment design to connect the fire with the specific fuel types, such as in the boilers and furnaces etc., involves both the arts and technologies.

### **2.2. Efficiency of Oil (Liquid) Burner vs. Gas Burner, and Turning Liquid Fuel into Gaseous Fuel for Effective Combustion – Gassified Burner**

Oil or liquid burners are common in industries. In the oil burners, oil is mixed under a control environment with air in an appropriate ratio, and sprayed with a nozzle with adequate pressure. The initial fire (ignition) is carried out by a spark or a pilot flame. In the oil burners the efficiency is reaching around 80 - 90% the maximum and there were efficiency drops with burner degradations [6]. For liquid fuels, other than the mixture of Air and fuel in proper ratios, the fuel atomization process is also very important for the enhanced combustion efficiency. The atomization process in liquid fuel burners may not have reached the 100% levels to achieve the highest efficient combustions. In gas burners, LPG gas is the most common fuel type, and the efficiency is easily exceeding 90% and even would reach 95%.

### **2.3. Development of a Gassified Petroleum Burner**

Fuel in the form of gas or fume is in the molecular form. Whereas, in the liquid fuel burners, the fuel is in tiny droplets or particles. The usage of gasification technologies in the liquid fuel combustion has an advantage in enhancing the affinity among air and fuel, in air-fuel mixtures, for effective and efficient combustion. Therefore, the strategic approach of oil or liquid fuel turning into gaseous fuel, prior to combustion, would improve the effectiveness and efficiency of burning. This would be important for minimizing fuel consumptions and for reducing carbon emissions. As a such, the project would contribute for environment health and sustainability. This project is focusing on liquid fuel gasification prior to make the fire, or in other words "gasified oil burner, for effective burning of liquid fuel". Here diesel is used as the fuel and is gassified by spraying on to a hot plate and try to keep flow rate by pressurising and using a flow control valve.

## **3. OBJECTIVE**

- To develop a functional prototype of liquid fuel gasification burner, for the local industrial, commercial, and household thermal applications.

Burners are mostly imported. It is important to have locally developed burners for the local use, as there are heavy usage of burners in industrial, commercial & light commercial, and domestic sectors in thermal applications. Liquid oil burners are the norm for the most of the industries. The efficiencies can be observed as 80-90% range as the highest seen in the specifications [6]. But when it comes to actual cases, the maximum would hardly reach the specified, because of the variation in the fuel qualities, and the level of atomization, and the deviations from the ideal testing conditions. Gasification of liquid fuel prior to combustion would bring positive results. Furthermore, the locally developed gassified burners could be produced in different capacities and sizes to suit the scale of application.

## **4. BASIC APPROACH IN THE DEVELOPMENT OF GASSIFIED PETROLEUM BURNER**

1. Diesel is used as the fuel.
2. Pressurize the misting nozzle (low-pressure high-quality atomizing misting nozzle spray injector) using a pressure pump because it is very important to break fuel liquid parts into very small (micro sizes) parts. That helps for the gasifying process.

3. When the diesel liquid is sprayed by the nozzle on to the hot plate (gasifier plate) which maintains the flashpoint of the diesel, it produces diesel fumes or gas.
4. The funnel enclosure collects the gas (gas enclosure) properly.
5. Then the blower supplies air which needs for the combustion.
6. Fuel flow rate and the air supply are controlled by using control valves.

## 5. THE DESIGN

### 5.1. Funnel and Hot Plate Design



Figure 1: Drawing of the funnel and the sub system assembly and structure

The above figure 01 reflects the design of funnel and the hot plate (gasifier plate). Mild steel is used as the material for the funnel and 5cm GI pipe is set to the upper part of the funnel. To control the temperature, a regulator is connected to the hot plate underneath the funnel. The above figure 01 also shows the drawings of the funnel and the sub system assembly and structure.

### 5.2. Fabricating the Funnel

After funnel fabrication, nozzle was fixed onto the side of the funnel and facing towards to the gasifier hot plate. A blower was connected to the funnel end pipe, to facilitate a draft of the gasified liquid, and also to mix with a primary air-supply, as to facilitate the combustion and to maintain a steady flame. The blower is mounted 30° angle with the GI pipe to collect the gas properly and avoid gases to go downwards and it provide enough air for the combustion. This system assembly is sealed to prevent gas leaks. Ebonite sheets are used to seal the hot plate and the funnel.



Figure 2: Fabrication of the funnel, Nozzle connection, Blower Connection, Complete assembly of standalone gassified liquid burner in operation.

Finally all the three assembled components, the nozzle, hot plate, and the blower are mounted in to a grid and a stand. Finally the pump, controller, and a liquid fuel storage is also mounted onto the same grid, to make it a standalone equipment. The above figure 2 shows the Fabrication of the funnel, Nozzle connection, Blower Connection, Complete assembly of standalone gassified liquid burner in operation.

### 5.3. Safety and Operational Considerations

- **Starting process:** Initially, the hot plate should be switched on because the hot plate should maintain flash point of diesel otherwise diesel liquid does not convert into gas form. Then fuel supply could be on, with the switching on of the blower.
- **Shut down process:** At first, pump should be switched off because it stops the diesel supply. Let the flame extinguished naturally. Next the air supply is cut-off, by switching off the blower. Finally switch off the hot plate.

## 6. RESULTS, TESTING AND ANALYSIS

In the prototype shown in the Figure 3, the burner shows a steady flame, with light yellowish in colour. The further improvement is possible with the better controlled air and fuels flows, and by providing a secondary air, and by installing a burner target.

### 6.1. Water Heating Test

With the available first flame, the below water heating test using 2 litres was carried out to evaluate the available potential of the efficiency of the burner.

#### Observation:

It took 14 minutes for 2 liters of water to increase the temperature from 30°C to 90°C. Diesel consumption is 125ml.

#### Data:

Specific heat capacity of water ( $c$ ) = 4200 J/kg.K

Density of water = 1000 kg/m<sup>3</sup>

Mass of 2L water = 2kg

Calorific value of diesel (CV) = 45.5MJ/kg

Density of diesel = 850.8 kg/m<sup>3</sup>

Mass of 125ml diesel = 0.1 kg

Water temperature rise during the heating  $\Delta T = 90^\circ\text{C} - 30^\circ\text{C} = 60\text{K}$

#### Energy Calculations:

Heat energy is taken by water =  $E_{\text{Water}}$

$$E = mc(\Delta T) = E_{\text{Water}} = (2\text{kg}) \times (4200\text{J/kg.K}) \times (60\text{K}) = 504000 \text{ J}$$

Thermal energy provided given by diesel =  $E_{\text{Diesel}}$

$$E = m \times (\text{CV}) = E_{\text{Diesel}} = (0.1 \text{ kg}) \times (45500000 \text{ J/kg}) = 4550000 \text{ J}$$

$$\text{Aluminum Pan: Mass 500g, Heat value - } mc(\Delta T) = E_{\text{Al Pan}} = 0.5 \times 903 \times 60 = 27090 \text{ J}$$

$$\text{Total heat } E_{\text{TH}} = E_{\text{Water}} + E_{\text{Al Pan}} = 531090 \text{ J}$$

## 7. DISCUSSION AND CONCLUSION

### 7.1. Burner Efficiency Evaluation

Water heating efficiency could be estimated as 20% = 0.20 of a standard heat exchanger. Even in a better heat exchanger efficiency would be around 65%. The above low-efficient water heating case, the efficiency is resulted as 20% of 65%. i.e. 13.00%.

$$\text{Heat supplied by the burner } E_{\text{BURNER}} = E_{\text{TH}} / 0.13 = 531090 \text{ J} / 0.13 = 4085307 \text{ J}$$

$$\text{Efficiency of the burner} = E_{\text{BURNER}} / E_{\text{Diesel}} = 4085307 \text{ J} / 4550000 \text{ J} \approx 90\%$$

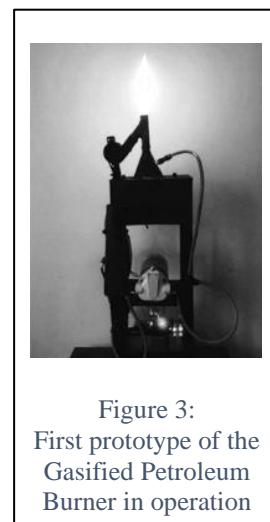

Figure 3:  
First prototype of the  
Gasified Petroleum  
Burner in operation

Considering 90% burner efficiency against 80% [6] of industrial oil burner efficiency, the gas burner prototype has exceeded the efficiency of the oil burner and has reached 90%. As the upper limit of the efficiency of newly commissioned oil burner based lab results would be 90% [6]. Yellow flame justifies the more room for improvements. Because the air-fuel mixture needs better ratios to achieve a blue flame. Also the secondary air-flow is yet to be introduced. Then we burner would be able to exceed even the laboratory based upper limit of the commercial oil burner efficiencies.

Because the air-fuel mixture needs better ratios to achieve a better combusted flame. Any 5% improvement of the burner efficiency would reach 95% combustion efficiency. Even during the situations like gas supply shortages, this solution could be a solution for commercial and industrial applications. There is a possibility of retrofitting such nature of systems to replace the gas burner systems. Compared to the liquid burners, the flame and emission would be less hazardous. This would be furthering into developing the customized burners for local household and industrial applications, including the bio-fuel oil varieties.

## REFERENCES

- Chilcott, R. P. (2006). *Compendium of Chemical Hazards*, Health Protection Agency, *Chemical Hazards and Poisons Division (HQ)*, Chilton, Didcot, Oxfordshire, OX11 0RQ, United Kingdom.
- Gowlett, J.A., (2016). The discovery of fire by humans: a long and convoluted process. *Philosophical Transactions of the Royal Society B: Biological Sciences*, 371(1696), p.20150164.
- Kumar, P. and Rehman, A., (2016). Bio-diesel in homogeneous charge compression ignition (HCCI) combustion. *Renewable and Sustainable Energy Reviews*, 56, pp.536-550.
- Majewski, W. A. (2012). *What Are Diesel Emissions*, DieselNet Technology Guide. PROGAS, *Properties of Diesel*, <http://progas.jo/lpg-vs-diesel/> [Accessed on 02 August 2021].
- Sarma V.P. (2003). *Fuel Chemistry*, *Encyclopaedia of Physical Science and Technology* (Third Edition), Pages 253-274.

# Multiple Linear Regression Method for Predicting Mechanical Properties of Low Carbon Steel during In-Process Inspections

K. G. Alahapperuma<sup>\*</sup>, N. Nandhakumar<sup>2</sup>

<sup>1</sup>Department of Mechanical and Manufacturing Technology, University of Vocational Technology, Sri Lanka

<sup>2</sup>Ashok Steel Company PLC, Ja-Ela, Wattala, Sri Lanka

## ABSTRACT

*Low carbon steel is regarded as a popular category of materials due to its attractive mechanical and fabrication characteristics. Chemical composition, physical parameters and mechanical properties should be maintained within acceptable limits, as per recommended standards. Usually, the composition of steel is tested during the melt stage while other properties are tested for finished products. If mechanical properties can be predicted during the manufacturing stage, it will help steel manufacturer save money and time spent on quality assurance. The study was aimed at predicting the tensile properties of low-carbon thermo mechanically treated (TMT) reinforcing steel bars within the manufacturing stages. Multiple linear regression analysis was applied to predict yield strength (YS), ultimate tensile strength (UTS) and elongation at break (EB), with chemical composition and mass per meter (MPL) as input variables. Linear relationships were derived for each property, and some correlations between input and output variables were positive, while others were negative. However, the relationship in each case was not statistically significant, since the P-value of each variable was greater than 0.05. Certain constraints faced and the assumed conditions might have affected the predictions. Since approximate values were sufficient, the derived relationships could be used to predict tensile properties during in-process inspections.*

**Keywords:** Chemical Composition, Low Carbon Thermo Mechanically Treated Reinforcing Steel Bars, Mass Per Unit Length, Multiple Linear Regression Analysis, Tensile Properties.

## 1. INTRODUCTION

Steel is the most widely used category of engineering metals, mainly due to its recyclability, strength characteristics, high strength to weight ratio and environmental favored characteristics. Its properties can be easily changed with heat treatments, as desired. The cost of steel is substantially low. Around 3500 different grades of steel are manufactured annually, by varying proportions and types of alloying elements (Texas Iron and Metal, 2021). In 2019, world crude steel consumption was figured as 1869 million tons (World Steel Association, 2020). As per other products, in manufacturing stages, steel properties should be maintained within acceptable ranges, as per the specified standards. In Sri Lanka, for steel reinforcing bars, chemical composition, physical parameters and mechanical properties should be complied with according to the SLS 375:2009 standard. Usually, steel chemical composition is tested during melt stages, and mechanical properties are tested for finished products. Tested mechanical properties essentially include tensile properties, while tested physical parameters include MPL, which means that steel bars are not necessarily aged, as in the case of testing for mechanical properties.

Of the tested tensile properties, YS is a critical property which determines the grade of steel. According to the standard, UTS is also highly important and the UTS/YS ratio should be a minimum of 1.05, according to the standard. The elongation property is measured at two points as per the standard requirements; at the maximum force and at the break point.

Although all, chemical composition and other specified properties need to be tested to comply with product requirements, there are instances in steel manufacturing processes where approximate values of mechanical properties are sufficient, when quick analysis is involved during in-process inspections.

---

\* Corresponding Author: E-mail - [gayanthi111@yahoo.com](mailto:gayanthi111@yahoo.com)

In this regard, if chemical composition and physical parameters can be used in determining mechanical properties of steel, it will enable steel manufacturers to save valuable quality assurance time and man power spent on experiments.

Use of data science techniques can be utilized in this regard, and related studies are found in the literature. Multiple linear regression was applied (Lim, 1991) to determine the mechanical properties of two grades of steel bars, with chemical composition as input variables. Seven different data science techniques of Random Forest, Neural Network, Linear regression, K- Nearest Neighbor, Support Vector Machine, Decision Tree, and Ensemble methods were applied (Sandhya et al., 2019) to determine tensile strength, with carbon percentage, bar diameter, processing temperature and manufacturing technique as input variables. In another study, artificial neural network (ANN) models were applied (Wang et al., 2020: 234) to predict tensile properties of austenitic stainless steel, and chemical composition, test temperature and heat treatment were the input variables. Those obtained models could be used as guidelines for design and development of austenitic stainless steels with expected properties. In a similar study artificial neural networks were implemented (Faizabadi, et al., 2014: 1993-1999), to determine the effect of chemical composition and tensile properties on the hardness and impact toughness of one micro-alloyed steel.

The specific purpose of this research is to approximately estimate the mechanical properties of final steel products, while those are still in production progress. The production process is usually held on a 12 hour shift basis, and testing of mechanical properties is a main component of the final inspection process. Especially in hot rolling mills having semi-automated systems or manual systems, it is preferable to test the same mechanical properties at some frequency in order to ensure that the product quality is sustained; generally, at a one hour interval, samples are drawn for testing. However, since the drawn samples are in hot condition, they have to be slowly cooled to room temperature, before testing for mechanical properties, which takes approximately 40–45 minutes. Since the production is in progress by this time, when the samples are tested and the results are found, the mill completes approximately one hour's production time. If the test results are not favorable, then further analysis should be carried out by quarantining that particular hourly production. If a method is applicable to estimate those mechanical properties, just after the samples are being drawn, it will be beneficial for those workforces involving production process.

Advanced data science techniques such as non-linear regression models or Artificial Neural Network (ANN) models are preferred for this sort of analysis. Since this is an initial study to observe the effectiveness of input variables on the predicted mechanical properties, multiple linear regression analysis was selected for the study. Accordingly, the objective of this study is to use multiple linear regression analysis to predict the tensile properties of YS, UTS and EB using carbon and manganese percentages and MPL as input variables.

## 2. METHODOLOGY

Forty mechanical test reports based on the fourth revision of SLS 375:2009 standard were collected from a steel manufacturing organisation<sup>1</sup>, for the 12 mm nominal diameter, TMT concrete reinforcing bars. Each test report was of 15 samples from the respective batch, as per the standard requirement. Corresponding physical parameters of each and every sample, and the chemical composition of each and every batch were also collected, and readings were averaged before being applied to the analysis.

The process parameters of billet temperature, flow rate of the water used for the thermo mechanical treatment, and its inlet and outlet temperatures were assumed to remain unchanged throughout the whole batch production process.

Multiple linear regression analysis was applied using Minitab software to 40 separate batches, to predict YS, UTS and EB, while C and Mn percentages and MPL were the input variables. Table 1 shows the input and output parameters with their relevant statistics used for the analysis.

Table 1: Input and Output Parameters and Their Statistics Used for Multiple Regression Analysis

Parameter	Unit	Maximum	Minimum	Average	Standard Deviation	Median	Variance
<b>Input</b>							
<b>C</b>	% by weight	0.24	0.18	0.213	0.0188	0.210	0.00034
<b>Mn</b>	% by weight	0.70	0.55	0.633	0.0504	0.635	0.00248
<b>MPL</b>	kg/m	0.905	0.887	0.900	0.0029	0.900	0.00001
<b>Output</b>							
<b>YS</b>	Nm <sup>-2</sup> *(10 <sup>6</sup> )	534.00	516.00	525.67	0.8747	525.00	23.1693
<b>UTS</b>	Nm <sup>-2</sup> * (10 <sup>6</sup> )	637.60	613.60	627.54	5.9831	627.00	34.9025
<b>EB</b>	% of original length	21	15	16.775	1.4586	17	2.0744

Note: Mechanical test reports of 12 mm nominal diameter, TMT concrete reinforcing bars of grade 12RB500, low carbon steel, supplied by one of the steel manufacturing organisations in Sri Lanka were the source of data. Each test report contained data belonging to 15 samples from the concerned batch.

### 3. RESULTS

The regression equation for YS is given in equation (01).

$$YS = 31 - 16MPL + 64.5(C\%) - 6.7(Mn\%) \quad (\text{Eq: 01})$$

The two graphs of expected values and experimental values of YS are shown in the figure 1.

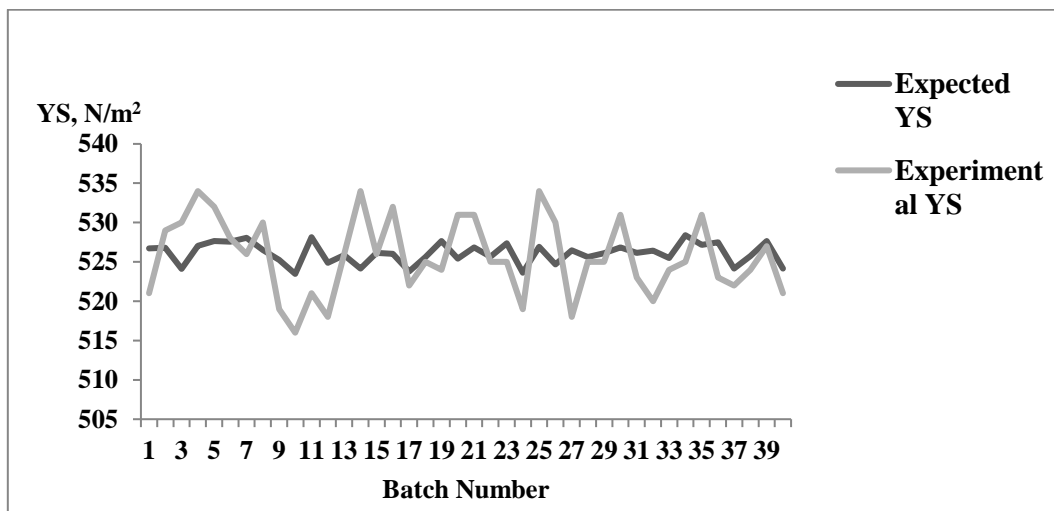

Figure 1: Expected and Experimental Values of YS

The regression equation for UTS is given by equation (02).

$$UTS = 853 - 233MPL - 17.5(C\%) - 18.9(Mn\%) \quad (\text{Eq: 02})$$

Figure 2 indicates the graphs of expected values and experimental values of UTS.

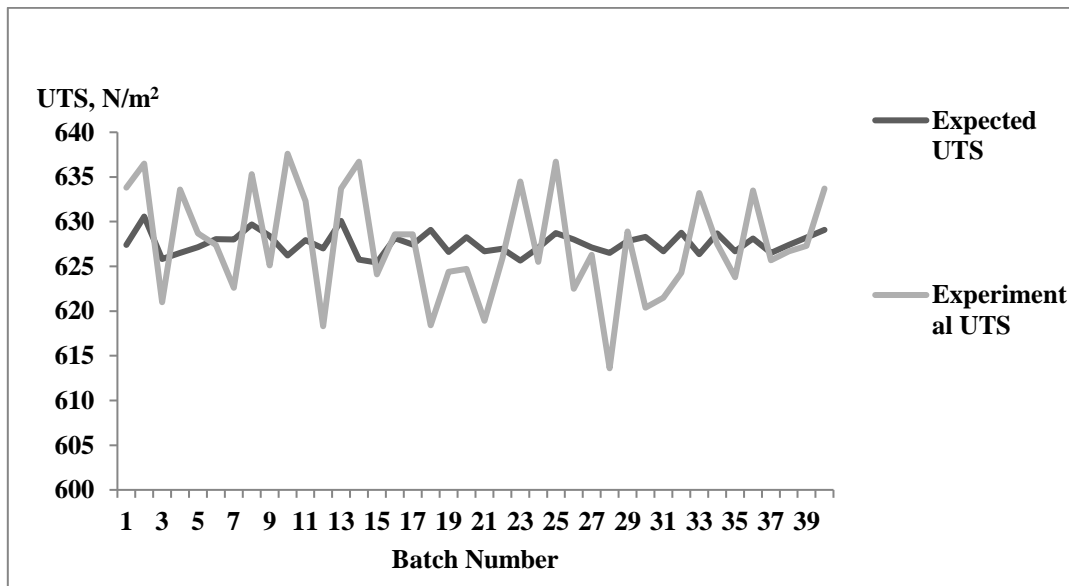

Figure 2: Expected and Experimental Values of UTS

The regression relationship for EB is given by equation (03).

$$EB = 41.6 - 31.9MPL + 21.6(C\%) - 1.04(Mn\%) \tag{Eq: 03}$$

Figure 3 shows the expected values and experimental values of EB.

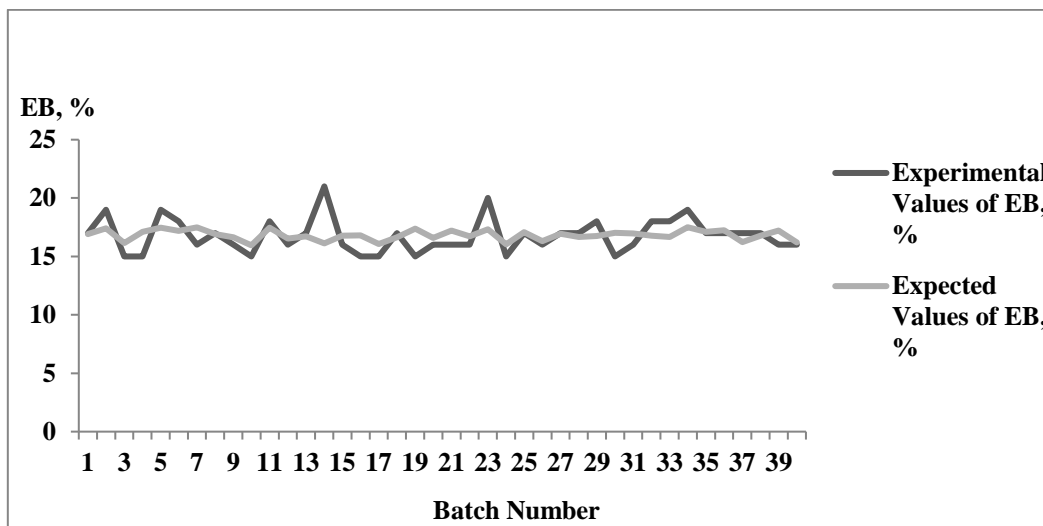

Figure 3: Expected and Experimental Values of EB

#### 4. DISCUSSION

According to the results, linear relationships were derived for all three properties. The yield strength shows a highly positive correlation with C%, and moderately negative correlations with MPL and Mn%. UTS shows moderately negative correlations with C% and Mn%, while its correlation with MPL is highly negative. EB shows a moderately positive correlation with C% and a moderately and slightly negative correlation with MPL and Mn%, respectively. The obtained P-value of each variable is greater



than 0.05 and the  $R^2$  values were 30.4%, 31.4% and 25.6% for the three tensile properties of YS, UTS and EB, respectively. These imply association in each case is not statistically significant. The study was conducted under several limitations and assumptions, which might have affected the results.

Only 40 test reports were taken for the analysis and the average values were taken into account in order to make the work easy, since this study is the first attempt to find the association of the known variables to predict the parameters expected. Also, chemical composition was taken for the batches and not for the individual bar samples.

Even though the process parameters such as billet temperature, flow rate of the water, inlet and outlet temperatures of water were assumed to remain unchanged, and that parameters were maintained as per the process requirements throughout the batch production process, there are possible variations in the time-line as per the operational manual of semi-automated hot rolling mills.

In the case of chemical composition, even though the major elements were taken into account, other elements such as Mo, Cr, Cu, V, S and P, which weren't considered in this analysis, are also available in this grade of steel. Even though the function of each alloying element is thought to be independent, there can be interactions between the functions of different elements. Therefore, the carbon equivalent value would have been considered as an input variable instead of each alloying element.

The analysis was also focused on only one type of product, which is the 12 mm nominal diameter ribbed bar out of the preferred range of products. However as per the SLS 375 2009 standard, the preferable range of products are those with the nominal diameters of 8 mm, 10 mm, 12mm, 16 mm, 20 mm, 25 mm, 32 mm and 40 mm.

This study was an initiation of the approach to reduce the time consumption during the in-process quick analysis. Since approximate results are sufficient, all these three relationships of tensile properties, with the main alloying elements and MPL as input variables, will help the teams of steel manufacturing process to make suitable adjustments to the process conditions within the required time of production.

## **5. CONCLUSION**

Nowadays, data science techniques help material science techniques to predict mechanical properties. This idea implies the replacement of conventional experimental methods with these data science based methods for determining the mechanical properties of final products. However, the reliability of data science based approaches in predicting the mechanical properties is solely dependent on the accuracy of the input data and the means of obtaining them.

This is an initiation of the research work with the linear regression model, and the study has certain limitations. However, the obtained results will be sufficient for the intended purpose of predicting approximate mechanical properties, for quick analysis during manufacturing stages.

## **6. RECOMMENDATIONS**

The model has to be further developed by considering the other chemical elements and other applicable variables, such as the process parameters and heat treatment conditions etc. It is recommended to consider other preferable range of products and apply a considerably higher number (minimum 100) of data sets when the study is extended, expecting a higher accuracy.

The analysis can be focused on non-linear multivariate relationships or any other preferable mathematical models, for the expected higher accuracy.

**REFERENCES**

- Faizabadi, M. J., Khalaj, G., Pouraliakbar, H. and Jandaghi, M.R. (2014). Predictions of toughness and hardness by using chemical composition and tensile properties in microalloyed line pipe steels. *Neural Computing and Applications*, 25(7), pp.1993-1999.
- Lim, W.T. (1991). Statistical analysis of reinforcing steel properties.
- Sandhya, N., Sowmya, V., Bandaru, C.R. and Babu, G.R. (2019). Prediction of mechanical properties of steel using data science techniques. *Int. J. Recent. Technol. Eng*, 8(3).
- Sri Lanka Standard Institution. (2009). *Sri Lanka Standards 375:2009 (Specification for Ribbed Steel Bars for the Reinforcement of Concrete (UDC 669.14-122.4:691.714:691.328., 4<sup>th</sup> ed., pp. 17)*. Victoria Place, Elwitigala Mawatha, Colombo 08.
- Texas Iron and Metal. (2021). *Five Most Popular Types of Metals and Other Uses*. <https://www.texasironandmetal.com/most-popular-metal-types/>
- Wang, Y., Wu, X., Li, X., Xie, Z., Liu, R., Liu, W., Zhang, Y., Xu, Y. and Liu, C., (2020). Prediction and analysis of tensile properties of austenitic stainless steel using artificial neural network. *Metals*, 10(2), p.234.
- World Steel Association. (2020). *World Steel in Figures*. Retrieved from <https://www.worldsteel.org/en/dam/jcr:f7982217-cfde-4fdc-8ba0-795ed807f513/World%20Steel%20in%20Figures%202020i.pdf>

## **HARMONIOUS COHABITATION OF ICT IN VOCATIONAL TECHNOLOGIES**

# Awareness of Internet Browsing Security among Undergraduates in Rajarata University of Sri Lanka

D.N. Jayathunga<sup>1</sup>, D.M.T. Madushanka<sup>\*2</sup>

<sup>1</sup>Faculty of Management Studies, Rajarata University of Sri Lanka

<sup>2</sup>Library Division, University College of Matara, Sri Lanka

## ABSTRACT

*Internet users have some issues as a result of their reliance on the internet for their needs, and they are particularly exposed to unwanted third parties. Students in higher education, in particular, use the internet for a variety of objectives without considering the safety of browsing. According to certain research, the majority of students have concerns with internet security knowledge. Based on the pilot survey, results obtained from the students in Rajarata University of Sri Lanka motivated the researchers to conduct the research intending to assess the levels of Internet Browsing Security Awareness among undergraduates of Rajarata University of Sri Lanka and to suggest security measures to overcome internet vulnerabilities. Data was collected from 300 undergraduates in six faculties of Rajarata University of Sri Lanka using a structured questionnaire. The questionnaire tested the awareness of students on four variables including knowledge of malware, use of strong password and knowledge of third-party security towards the Awareness of Internet Browsing Security. The collected data was analyzed using the statistical analysis tools SPSS and MS Excel. Hypotheses were tested using correlation analysis and regression analysis. All the hypotheses were accepted while supporting 52.3% explanatory power of independent variables to the dependent variable. The level of awareness on the secured browsing behaviour of the undergraduates was identified to be at a satisfying level. Further, based on the findings, the researcher recommends that the university should organize programs to increase the level of knowledge of undergraduates about safe internet exploration.*

**Keywords:** Internet Browsing Security, Safe Browsing Behaviour, Third-Party Security.

## 1. INTRODUCTION

Internet browsing awareness can be defined as a method of making users awareness about the safe browsing behaviour of the Internet. In organizational perspective, it is making aware the members working in the organization on the company data regarding the guidelines and protocols relating to the security, especially when they are connected to the company's network. (Alotaibi and Alfehaid, 2018)

With advances of technology and the way in how Information Technology (IT) is fast defining the global environment, there is a growing trend in the academic discourse on the need to fully incorporate IT into the academic environment to support learning, studying and teaching processes (Ndiege and Okello, 2018). Individuals' information security awareness (ISA) is a key factor in determining their security-related behaviour in both the workplace and at home (Jaeger, 2018).

When it comes to the field of the higher education sector not only in global with Covid 19 barriers all the higher education institute and even local government schools also moving to the integration of ICT for the teaching and learning processes. Especially the students who are in the universities and other higher educational institutes are doing self-learning by visiting the online educational platforms around the world. They become victims of being exposing their privacy to the third party if they do not follow the proper mechanisms to protect their browsing behaviour themselves. With the expectation of measuring the level of awareness and student's safe browsing behaviour who are studying in the local university network, this study conducted to test the above purpose using the undergraduates in the Rajarata University of Sri Lanka.

---

\* Corresponding Author: E-mail - [thilina.dmt@gmail.com](mailto:thilina.dmt@gmail.com)

## 2. RESEARCH PROBLEM

Almost every country on the earth has seen a rapid increase in the use of information technologies over the last decade. The rise in computer ownership and Internet access has impacted the lives of millions of people who go online every day at home, school, work, and other locations such as Internet cafés. They use the internet to send and receive e-mails, communicate, conduct school or work-related research, download music or images, and a range of other things (Ndiege and Okello, 2018).

Easily accessible computer hardware and software have made many people aware, but on the other hand, increasing the use of computers for illegal purposes. Information Communication Technology (ICT) bring together an alteration that makes ethical concerns. The future peers of ICT experts desires to be equipped to face the proper encounters of a technologically and an open-world (Horsman, 2020).

As a result of the prevailing situation emerge with the Covid 19 pandemic situation all around the world move to online methods of teaching and learning process. Including minor grade students, it spreading to the students who are studying for doctoral degrees also. Whatever the devices like mobile phones, tabs, laptops and desktop computers, the learners open to space and the information vulnerabilities are starting because most of the students are using their father's or mother's or siblings' devices to connect to the internet. In most cases, the devices might be using to do their job or businesses. All the information regarding job and business is there. But the students do not have an idea about the value of those information and the type of vulnerabilities they may face when they are browsing at the internet. How does it happen? Intruders are sending popup messages that showing numerous offers. Especially the kids and young generation tend to look on that and they become vulnerable once they just click such messages.

There have been a number of studies showing the progress and gaps of the ISA in the academic field, and the lack of studies focusing on students attending universities in developing countries is remarkably low in the information security literature. Keeping all these aspects in mind, the specific objective of this research is to contribute to the existing literature on ISA in universities in developing countries (Ndiege & Okello, 2018).

This study is launching to investigate awareness of Internet browsing security and the level of protection against ICT related vulnerabilities of undergraduates at the Rajarata University of Sri Lanka (RUSL). Similarly, it would be advantageous for institutions of higher education to have an ISA program as part of a particular subject or to conduct ICT-related security awareness workshops to increase the students' knowledge. Before the study, the researcher conducted a pilot survey to identify the current situation and get justification for the issue of this study. The researcher used the pilot survey to identify the current awareness of secure internet browsing behaviour of undergraduates in RUSL. The respondents of that survey were 30 undergraduates. It represented 5 (five) undergraduates from six faculties currently available in the Rajarata University. The result of that pilot survey can be summarized as follows.

According to the results of the pilot survey, 76 % of respondents stated that they are unaware of safe browsing, 59 % have not installed third-party security guards on their devices, and 81.1 % of students stated that they have not received any awareness of Internet Browsing Security training from the university or computer centres, and it seems to that the remaining respondents are aware of safe browsing based on the knowledge gained by self-studying.

According to the information provided above, Internet Browsing Security awareness among Rajarata University undergraduates is fairly low. Therefore, the researchers decided to observe and find out reasons which were affected the level of awareness of Internet Browsing Security among Undergraduates at the Rajarata University of Sri Lanka.

### **3. RESEARCH QUESTIONS**

#### **3.1. The Main Research Question**

What factors impact on the awareness of Internet Browsing security among Undergraduates in RUSL?

#### **3.2. The Secondary Research Questions**

- How does knowledge about the malware affect the Safe internet browsing of Undergraduates in RUSL?
- How does the awareness of Strong Password Usage affect the Safe internet browsing of undergraduates in RUSL?
- How does the knowledge about third party security affect the Safe Internet Browsing of undergraduates in RUSL?

### **4. LITERATURE REVIEW**

#### **4.1. Internet Browsing**

Every day, millions of people all across the world utilize the internet. They use it to “send and receive e-mails, chat, conduct school or work-related research, download music and photos, and a number of other things”. Over the last decade, the number of people who use the internet has risen tremendously and the same time some of them have become the victims of intruders (Ndiege and Okello, 2018).

#### **4.2. Internet Browsing Security**

Distance learning has forced students into online learning environments where they don't have time to ensure their online protection. It's one of the virtual classroom's obstacles, and it's a crucial one to overcome. Even though students are now digital natives, there is still a need to assist them in safely navigating the online world (Ndiege & Okello, 2018).

#### **4.3. Awareness of Internet Browsing Security**

The importance of information security awareness (ISA) in reducing the risks associated with data security breaches cannot be overstated. As a result, raising ISA levels among line users reduces the risk of them causing information security breaches, improving the effectiveness of countermeasures that universities implement to protect themselves and their constituents from information security-related issues. Those who use information technology (IT) assets must be aware of the necessity of protecting information systems and related resources (Wiafe et al., 2020).

#### **4.4. Risk Awareness**

Security and privacy are extremely relevant in the operation of the Internet. Other network users can use your presence on the Internet for malicious purposes. “Identity theft, lack of privacy, the transmission of unwanted information, profiling, and other threats” put sensitive data at risk. Trolling and hate are antisocial phenomena that describe certain activities (Laskowski, 2017).

#### **4.5. Security Measures**

As you all are aware that web browsers are the main portal that open users to vulnerability. But in case of avoiding these vulnerabilities, internet users can protect themselves from being victims of a third party. Especially the students who are engaging the learning process needed to be updated with the measures that protect the browsing behaviour. As such measures, awareness about virus protection, system backups, and use of removable media, Software installation and system access maintenance is important to be safe from such vulnerabilities.

#### **4.6. Self-Perception of Internet Browsing Security Skills**

Those with high self-efficacy who believe they can accomplish a task will be inspired to do so. As a result, self-efficacy is viewed as an antecedent of compliant activity in addition to the understanding of information security environment (Yıldırım and Mackie, 2019).

## 5. RESEARCH METHODOLOGY

### 5.1. Conceptual Framework

The conceptual framework is the establishment for this whole research and it considered knowledge of malware, use of strong password usage and knowledge of third-party security as the independent variables while checking the awareness of Internet browsing security as the dependent variable. The diagram is showing in Figure 1.

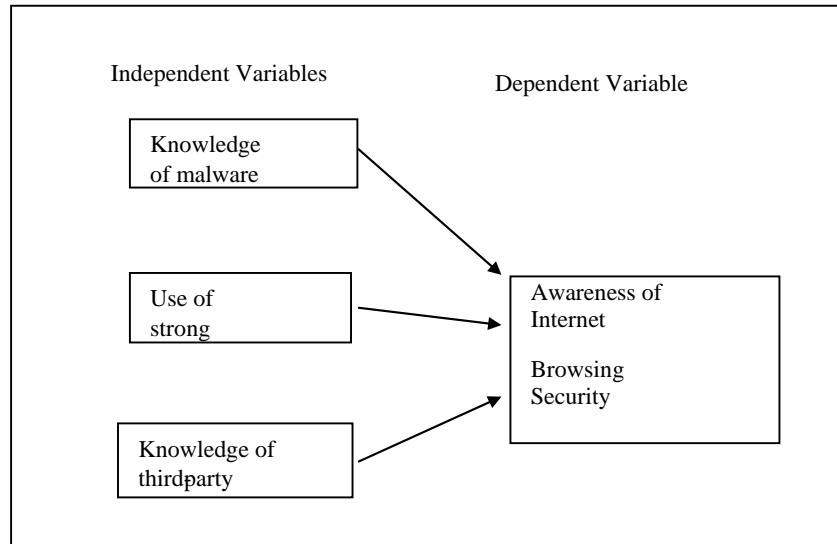

Figure 11: Conceptual Framework

### 5.2. Independent Variables

#### 5.2.1. Knowledge about the Malware

A collection of instructions for a computer to conduct a sequence of mathematical or logical operations is known as computer software. Computer software is divided into two categories: system software and application software. Application software is layered on top of business applications, allowing the system to do a variety of activities. Malicious software, commonly referred to as Malware, is software that is intended to harm a device, a user, or an entire system (Profile, 2019). Based on several studies there are some findings on students in higher education institutes face numerous issues on their digital privacy therefore researchers developed below hypotheis to test using the undergraduates in Rajarata University of Sri Lanka.

*H1: 'There is a significant impact on knowledge about the malware and secure internet browsing behavior of the Undergraduates in RUSL'.*

#### 5.2.2. Awareness of Strong Password

Before giving access, an entity's (human or non-human) identification must be confirmed through authentication. Anyone, from corporate system managers to home computer users, is affected. The most frequent type of authentication is a "username and password combination". The three sorts of authentication are "something you know (passwords), something you have (a card), and something you are (biometrics)" (Yıldırım and Mackie, 2019). Most of students are using their names, the number of their national identity card, birthday and mobile number so on. Intruders and third-party vulnerabilities can those things and it affects for the safety of students at the internet. Therefore, researchers developed below hypothesis to test the safety of undergraduate at the web.

*H2: 'There is a significant impact on strong password usage and secure internet browsing behavior of the Undergraduates in RUSL'.*

### 5.2.3. Knowledge of Third-Party Security

Users appeared to adopt and rely on off-the-shelf or third-party security tools, but privacy options were few. The usage of third-party tools may raise additional privacy concerns, as these programs may collect information about users that they are unaware of (Balapour, Nikkhah and Sabherwal, 2020). Most of the individuals are not motivated to use a third party security guard and if some are used they do not keep it up to date and do not enable advanced security modes, because of they might not well aware about managing their security guards (West and Zentner, 2020). Therefore researchers expected to test the level of awareness and its impact on the users security by developing and testing the below hypothesis.

*H3: 'There is a significant impact on knowledge third party security and secure internet browsing behavior of the Undergraduates in RUSL'.*

## 5.3. Dependent Variables

### 5.3.1. Internet Browsing Security

Security has a wide range of uses in today's digital world. The Internet and Internet-based social networking are becoming increasingly important to all. As the number of cyber-attacks against computers grows, security becomes more critical. Attacks are carried out in order to steal a web user's personal and financial details. For host systems, malicious content loaded into the device lacking the user's mindfulness is a common matter. The nature of the issues is the same for Smart-phones and Desktops. Infections, Trojans, ransom ware, and vulnerabilities in applications are all dangerous substances (Shital and R., 2017).

## 5.4. Method of Data Collection and the Sample

The purpose of this study is to look into the awareness of Internet Browsing Security among undergraduates at Rajarata University. This is “explanatory research that tries to build up the relationship among the factors using the available literature”. “Survey method is used as the strategy for this study as it is widely used in deductive researches”. As this research is conducted to investigate the awareness of Internet Browsing Security among undergraduates in Rajarata University of Sri Lanka, and data collected from each individual and treating each student's response as an individual data basis, the unit of analysis was at individual level. Undergraduates of Rajarata University of Sri Lanka were identified as the research population. Six faculties with the respective number of students are mentioned below.

Table 1: Population of the Study

Faculty	Student Population
Faculty of Agriculture	535
Faculty of Applied sciences	815
Faculty of Management studies	1612
Faculty of Medical and allied sciences	1080
Faculty of Social sciences and humanities	1642
Faculty of Technology	1046

Source : Students' Registration Department of Rajarata University (2020)

In this study, the researcher has selected three hundred undergraduates. That sample chosen by using a “stratified sampling technique” and then after using “convenience sampling technique” as follows. To identify the units that need to take into consideration of each stratum. The whole population of the study were divided into faculty wise and then decided to consider 5% of representation from each faculty. It was another sub group of the population and based on convenience technique, researcher distributed the questionnaire among list of undergraduates through online.

Table 2: Sample of the Study

Faculty	Student Population	Sampling	Sample
Faculty of Agriculture	535	535*5%	26



<b>Faculty of Applied sciences</b>	815	815 *5%	<b>40</b>
<b>Faculty of Management studies</b>	1612	1612*5%	<b>80</b>
<b>Faculty of Medical and allied sciences</b>	1080	1080*5%	<b>54</b>
<b>Faculty of Social sciences and humanities</b>	1642	1642*5%	<b>82</b>
<b>Faculty of Technology</b>	1046	1046*5%	<b>52</b>
			<b>300</b>

“Primary data” collected by a “structured questionnaire”. Secondary data collected through the previous research studies, documents, paper articles, magazines, reports and online published content.

### 5.5. Method of Data Analysis and Evaluations

Data gathered from questionnaires was analyzed by using the software IBM SPSS Statistics 21 version and descriptive statistics, Inferential Statistics, regression analysis were tested with other relative tests.

## 6. DATA ANALYSIS AND DISCUSSIONS

According to the time they have being with the technology for their education, Out of 300 students, 74 students using information technology within 1-3 years. Similarly, 101 students have been using information technology for more than 7 years. When considering the below the 1 year using information technology, It shows 15 of students.

The reliability results of both dependent and independent variables shows that Cronbach’s alpha value of all variables was ranged from 0.610 to 0.766, it fulfills the relevant accepted level of reliability and verify the internal consistency of the questionnaire.

In this study, descriptive analysis was calculated to identify the basic nature of the research variables. Mean, Standard Deviation the Skewness of the dependent variables and the independent variable was also calculated. mean value of the knowledge about the malware to Internet Browsing Security was 2.732 and the standard deviation was 1.11091. Mean value of the awareness of Strong Password to Internet Browsing Security was 2.898 and its standard deviation was 1.256. Mean value of the Third-party security to Internet Browsing Security was 2.479 and its standard deviation was 1.068. Likewise, mean value of Internet Browsing Security was 2.668 and the standard deviation was 1.109. Accordingly, above table indicates among respondents most of respondents Internet Browsing Security awareness but not much deviation among undergraduates answers about the Internet Browsing Security.

Regression analysis was used to explain how independent variables contribute to vitiate the dependent variable. Regression analysis shows the overall fit of the model. The researcher applied multiple regression analysis to test the hypothesis and adjusted R square to measure the overall fit of the model. R-value shows the simple correlation and it was 0. 723. The adjusted R square value indicates how much of the total variation in the dependent variable can be explained by the independent variables. According to the above result 51.8% of knowledge about the malware, awareness of Strong Password, Third-party security and Internet Browsing Security involvement was described by the independent variables taken under model 1 and the remaining 49.2 % of knowledge about the malware, awareness of Strong Password, third party security and Internet Browsing Security by other factors which are beyond in the study.

Table 3: Regression Analysis (Coefficient)

Model		Unstandardized Coefficients		Standardized Coefficients	t	Sig.
		B	Std. Error	Beta		
1	(Constant)	.640	.127		5.042	.000
	knowledge about the malware	.190	.043	.221	4.453	.000
	Awareness of Strong Password	.322	.044	.364	7.302	.000
	<b>Third party security</b>	<b>.257</b>	<b>.042</b>	<b>.295</b>	<b>6.062</b>	<b>.000</b>

The regression coefficient of knowledge about the malware indicates that it has a positive impact on Internet Browsing Security ( $\beta = 0.190$ ,  $p < 0.000$ ). That means it is reducing the Internet Browsing Security when reducing the knowledge about the malware. Then H1 was accepted.

The regression coefficient of awareness of Strong Password indicates that it has a positive impact on Internet Browsing Security ( $\beta = 0.322$ ,  $p < 0.000$ ). That means it is reducing the Internet Browsing Security when awareness of Strong Password not good. Then H2 was accepted.

The regression coefficient of Third party security indicates that it has a positive impact on Internet Browsing Security ( $\beta = 0.257$ ,  $p < 0.000$ ). That means it is reducing the Internet Browsing Security when Third party security behavior not good. Then H3 was accepted.

## 7. CONCLUSION, RECOMMENDATION AND FUTURE DIRECTION

Overall, respondents need to be familiar with the most common tools and techniques used to improve security, such as using antivirus programs, activating firewalls, opening trusted email attachments only, and the ability to identify spam emails. However, male and female awareness of new threats is insufficient and students need to build capacity to improve knowledge of online victimization. For example, the value of privacy should be taken into consideration, misuse of personal information by other means such as third party involvement.

The results of the current work concluded that there is a significant difference in the level of awareness of male and female users of Internet services, and it was found that female students pay more attention to internet browsing than their male colleagues. The findings showed that the level of internet browsing is not low among university students in Sri Lanka, but there are some knowledge gaps with new situations (R. T. S. Nagahawatta, 2020).

The study population was 6,730 undergraduates in Rajarata University of Sri Lanka and 300 undergraduates are selected as the sample from the population by using a simple random technique.

Primary data collected by using a “structured questionnaire”. It was used “Statistical analysis packages (SPSS package) (MS Excel package) to analyze data. Descriptive statistics including frequencies, a measure of central tendency (Mean, Median and Mode) and a measure of dispersion (standard deviation) use to analyze the gathered data from these questionnaires”.

The reliability analysis was carried out to determine the internal consistency of the research measurements. According to the reliability analysis results, the alpha value of knowledge about the malware, awareness of Strong Password, third party security and Internet Browsing Security were greater than 0.7. Therefore, this study finding explained all the measurements have high internal consistency. Out of 300 students, 44 of using information technology within 1-3 years. Similarly, 74 students using information technology within 3-5 years. 101 of using information technology within 5-7 years.

According to the correlation analysis results, it was there is a positive relationship between knowledge about the malware and Internet Browsing Security was 0.866. There is a positive relationship between Awareness of Strong Password and Internet Browsing Security was 0.866. Finally, there is a positive relationship between Third-party security and Internet Browsing Security was 0.924.

The regression coefficient of knowledge about the malware indicates that it has a positive impact on Internet Browsing. Because the significant value is below 0.05. Its significant value is 0.007. Furthermore, Awareness of Strong Password indicates that it also has a positive impact on and Internet Browsing Security. Because the significant value is below 0.05. Its significant value is 0.000. Finally, third-party security indicates that it also has a positive impact on and Internet Browsing Security. Because the significant value is below 0.05. Its significant value is 0.000. Therefore, all hypotheses were accepted. Based on the above details internet browsing security is moderate among undergraduate of the Rajarata University of Sri Lanka.

Undergraduates who are considered to be the spirit of the society will be appointed worldwide in various positions of employment and with the revolutionary change of the information technology in every aspect of the society It's required for the employers to have a manageable knowledge of information technology. At present, with the development of the Cloud concept, it's used everywhere in the world and every single individual is connected to the internet while working. Under these circumstances, undergraduates are in need of gaining the awareness of Internet Browsing Security as well as the knowledge of IT.

At present every student engaging with online learning platforms and they have unlimited internet access within the university premises and/or home. Therefore, they need to consider more about their safe browsing behavior and especially to protect their privacy against the third-party vulnerabilities. At least a firewall and third-party virus guard should be installed in their computers. Not only that there are some online portals that students can get aware about the safe internet browsing and researcher recommend students to follow them. Lecturers also have a responsibility to show the value of Internet Browsing Security awareness for undergraduates and should motivate them to aware on Internet Browsing Security. Better to arrange an awareness program as workshops.

Further this study should be launch all among the higher national educational bodies in sri lanka and should identify the students awareness on the safety at the internet.

## REFERENCES

- Alotaibi M and Alfehaid W (2018) 'Information Security Awareness: A Review of Methods, Challenges and Solutions', *Internet Technology and Secured Transactions*, (March), pp. 119–127. doi: 10.2053/ICITST.WorldCIS.WCST.WCICSS.2018.0016.
- Balapour A, Nikkhah H. R, Sabherwal R (2020) 'Mobile application security: Role of perceived privacy as the predictor of security perceptions', *International Journal of Information Management*, 52(July), p. 102063. doi: 10.1016/j.ijinfomgt.2019.102063.
- Horsman G (2020) 'The challenge of identifying historic "private browsing" sessions on suspect devices', *Forensic Science International: Digital Investigation*, 34, p. 300980. doi: 10.1016/j.fsidi.2020.300980.
- Jaeger, L. (2018) 'Information Security Awareness : Literature Review and Integrative Framework', 9(3), pp. 4703–4712.
- Ndiege J, Okello G (2018) 'Information Security Awareness amongst Students Joining Higher Academic Institutions in Developing Countries: Evidence from Kenya', *The African Journal of Information Systems*, 10(3), p. 4.
- Profile S. E. E (2019) 'Impact of Malware in Modern Society Impact of Malware in Modern Society Abstract ', (June).
- Shital P and R., C. (2017) 'Web Browser Security: Different Attacks Detection and Prevention Techniques', *International Journal of Computer Applications*, 170(9), pp. 35–41. doi: 10.5120/ijca2017914938.
- West T and Zentner A (2020) 'Threats and Major Data Breaches: Securing Third-Party Vendors', *SSRN Electronic Journal*. doi: 10.2139/ssrn.3532024.
- Yıldırım M and Mackie I (2019) 'Encouraging users to improve password security and memorability', *International Journal of Information Security*, 18(6), pp. 741–759. doi: 10.1007/s10207-019-00429-y.

# Challenges in the Use of Big Data Analytics

M.I.M. Rifkhan<sup>1\*</sup>, ZAM. Safzath<sup>1</sup>, HPAI Pathirana<sup>2</sup>

<sup>1</sup>Department of Network Technology, University of Vocational Technology

<sup>2</sup>Department of Software Technology, University of Vocational Technology

## ABSTRACT

*In this modern world, vast amounts of data which are found in billions are created every day through modern information technology systems that can be found in various sources. Big data especially dominates sectors such as agriculture, banking, data mining, education, chemistry, and global finance, cloud computing and marketing. Managing such unprocessed information through manual data handling methods is a hopeless task. Analyzing from such massive data requires a variety of initiatives to be used for organizational decisions. Similarly, big data analytic is a method used by enterprise decision makers to discover what is hidden in big data, detect inconsistencies in data that are incomprehensible, and identify sensitive data that is related to the source. Therefore, big data analysis is a current area of research and development. The main purpose of this study was to investigate the impact of big data and its potential impact on the development in the industry. Further, the paper discusses related applications, tools and challenges of using big data. As a result, this paper provides some understanding on platforms to analyze big data with inherent challenges. In addition, this study provides important findings in the big data context contributing other researchers involved in searching ways to overcome the challenges associated with big data and addressing related issues.*

**Keywords:** Apache Cassandra, Apache Hadoop, Apache Spark, Big data.

## 1. INTRODUCTION

In the modern world, data comes from different sources. The data thus obtained is further enhanced by various technological developments that lead to the conversion of such data into big data. Big data, which has been transformed, emerges from a wide variety of fields and appears as a set of massive Datasets in each sector. Big data is seen by traditional methods and used in existing tools. If you look at these types of Big data, they can be found in structured, semi-structured, and unstructured formats like Exa Byte. Typically this type of data is categorized into a number of attributes. Several types of analysts have classified it as 3V, 4V, and 7V. Of these, 3Vs refer to volume, velocity, value, veracity, variability, visualization, and variety. In addition, many characteristics have been noted by many researchers. Volume refers to the huge combination of data that can be generated during a day-to-day operation. Similarly, velocity is the rate of growth and how fast the data are used for the analysis and variability attribute of the data structure (Kakhani, Kakhani and Biradar, 2013). Similarly, the main objective of big data Analysis is to implement the above-mentioned characteristics using a variety of ancient techniques. Moreover, some of these extraction methods are obtainable helpful information was discussed by Gandomi and Haider (Gandomi and Haider, 2015). Which follows, gives a clear description of big data. But until now the exact definition of this has not been defined. This is because many studies have shown that there are many problems with this. However, it helps us to solve problems better, find sophisticated, efficiently manage issues, while optimizing and being innovative and cost-effective.

“According to their sixth edition of DOMO's report, more than 2.5 quintillion bytes of data are generated every day. This number is expected to increase further. It is estimated that by 2020, 1.7MB of data will be generated every second of every human being on Earth (Ahmad, 2019)”.

“In the last two years, 90% of the world's data has been generated” (Loechner, 2019). These are all considered to be data generated by Online Usage. Moreover, from the perspective of ICT, Big data will

---

\* Corresponding Author: E-mail- [mimirifkhan95@gmail.com](mailto:mimirifkhan95@gmail.com)

no doubt be a strong impetus for the upcoming generation. Not only that, it depends on cloud computing areas, internet of things sector and social media, weather prediction and social business.

In general, data warehouses have been used to manage large datasets. In this situation, the key issue is the extraction of important knowledge from the Big data available. It is impossible to obtain and manipulate data from these types of big data, using a systematic data mining system that can be evaluated and retrieved from an existing massive database. The most important issue in the analysis of big data is the lack of integration between the database system and the analysis tools. These practical applications for discovery and representation of knowledge we wish to perform when faced with challenges. The underlying problem is that it is unable to adequately explain the important characteristics of Big data. Nowadays, everyone needs to know about the evolution of data. In addition, by examining complexity theory of big data, it helps to understand the complexities of big data, its key characteristics, simplify its representation, gain complete knowledge of abstraction, and build algorithms on big data. Many researchers have carried out this study. However, no decision-making process or analysis can be produced by looking at big data. With this kind of Big data, many companies are interested in finding out the links between them. This paper focuses on Big data and its challenges. We also mentioned the open research issues that can be found in Big data.

## 2. METHODOLOGY

The study is a review and implemented a quantitative approach. Using a quantitative approach allowed us to quantify the draw backs of big data analyzing tools. This has been analyzed based on available literature relevant to the big data and its tool to find out effective implementation the proposed solution. All major components of big data tools and other related aspects are evaluated to emphasis proper function of big data tool's requirement in background study. Then proper ways of implementation big data tools' techniques are analyzed in different aspects.

To evaluate the accuracy of the results of big data tools and its future prospective analysis, a research design has been prepared and this research follows qualitative approach based on available literature.

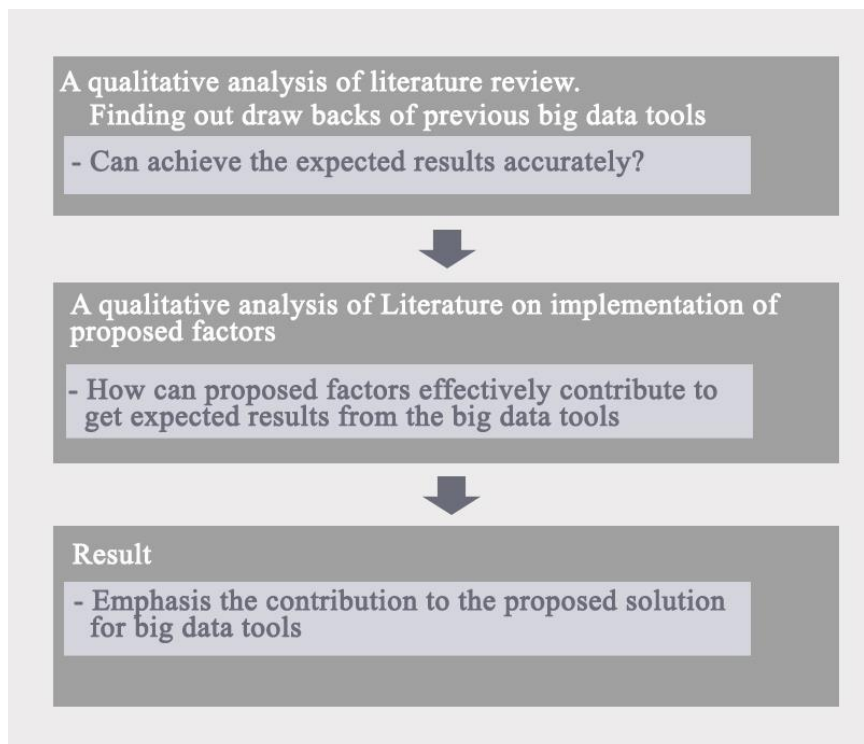

Figure 1: Research Design

### 3. RELATED WORK

Many papers have been surveyed that provide better understanding of the big data progressive techniques required for document analysis. It is summarized in Table 1.

S. No	Author Name(s)	Techniques/Tools discussed
01	D. P. Acharjya, Kauser Ahmed P	Apache Hadoop and MapReduce, Dryad,
02	Aaron M. Cohen1, et.al	Regarding Storage of the Information
03	Moustafa Sadek Kahil, Abdelkrim Bouramoul	Interactive Visualization
04	R. S. Raghav, et.al	Data Visualization, Big Data, SNA, BDA, BIA
05	Yasir Arfat, et.al	MapReduce, HDFS, Spark, YARN, Apache, Pig Hive
06	Nawsher Khan, et.al	51 V's of Big Data
07	Vaikunth Pai T	Google's Dremel, Apache drill,

Table 1: Literature Survey of Various Papers and Algorithms

### 4. CHALLENGES IN BIG DATA ANALYTICS

Big data needs to be analyzed in order to deal with these challenges, such as various computational complexities, information security, and computational methodologies.

At present, data is one of the most valuable assets. The value of a data is analyzed and determined by the idea available from it. Big data and analytics are still in the early stages of development but their importance cannot be underestimated. As Big data grows and expands, the importance of data and analytics continues to grow in business and personal life on a daily basis. In addition, as the size and capacity of Big data increases day by day, there is a need to explain the importance of it. Here we will discuss the challenges of big data analytics.

Through the use of big data analytics, companies monitor the day-to-day operations of their companies through surveillance conducted by large companies. Given the growing popularity of big data analytics, it is obvious that investing in this media is going to protect the future growth of companies and brands.

In fact, the value of a data product comes from big data analytics. That is why more and more companies are turning their attention to analytics. More and more companies are using more and more methods to analyze big data analytics. However, there is no valid solution to date. For a company, although data is important, the most important process is to get insights with their help.

Nowadays, cooperate companies are growing at a rapid pace and are making major technological advances. This means that brands must be prepared to pilot and adopt big data to become a combination part of the information management and analytics infrastructure. With amazing energy, big data is a growing unquiet force today, ready to become the next bigger thing in the field of integrated analytics, thereby changing the way brands and companies carry out their duties across positions and economic system.

However, even though these are seen with great potential and potential, there are major challenges and obstacles. This means that organizations must overcome all obstacles, and turn the full potential of big data analytics and related fields into a company's favor. Big data Analytics Challenges When properly carried out, the percentage of problems associated with big data analytics will decrease. Since Big data is a part of the world's top companies, overcoming its challenges is of paramount importance.

We think that the big data analytics program here today can present some of the biggest challenges ahead.

- 1 It is impossible to define the landscape of data management - because big data is not only an ever-expanding, new business and technology marketplace, but also an ever-evolving set of technologies. The biggest challenge for many companies at present is the use of technology that can be seen as problem-free and risk-free.
- 2 Set all Big data in One Platform - Data is increasing day by day. This means that more and more companies are looking to manage a certain amount of data on a day-to-day basis. The amount and variety of data available today makes it impossible for any data manager to manage, which is why making data access easy and convenient for managers and owners.
- 3 Integration of different types of data resources - Since each batch of data is viewed differently, there is a need to combine the elements together. If this is ignored, this will not only cause massive expansions between the data, but will also provide false insights and information.
- 4 Get Big Insights Using Big Data Analytics -. Getting the right and most accurate insights from Big data Analytics is critical. Moreover, it is very important that the right departments have the right information and the right information. One of the biggest challenges in big data analytics is how to bridge this gap in an efficient way.

## 5. WHAT COMES NEXT FOR BIG DATA

With the massive change in cloud technology, one of the key considerations of designing digital architecture is the need to fight back the ever-increasing demand for data. In the world where exchange, register, and even IT infrastructure can exist in a purely realistic state, a good big data approach creates a holistic overview by assimilate data from many sources, including; customer attitude and preference tracking, geolocation data, social channels data, inventory levels and shipment tracking, global network traffic patterns.

Even the most careful analysis of large data trends points to a steady decline in local infrastructure and increasing reliance on virtual technology. With this emergence there will be a growing reliance on tools and partners that can manage the world as machines are replaced by imitation bits and bytes.

Big data is not part of the future, it may be the future itself. The way businesses, companies and IT professionals who support them access their work will continue to be shaped by the change in the way we store, process, and understand data.

## 6. COMMON TOOLS FOR BIG DATA PROCESSING

In modern world, there are many tools to process Big data. In this section, we will talk about some of the important emerging tools that are currently widely used for analyzing big data. This includes more tools such as batch processing, stream processing, and interactive analysis. Most batch processing tools have Apache Hadoop infrastructure such as Mahout and Dryad. Likewise, most Stream data applications use real-time analytics. An example of a large-scale streaming platform is Storm and Splunk. The interactive analysis process allows users to contact them in real time for their own research. Dremel and Apache Drill are seen as big data platforms that can support interactive analysis. Moreover, these tools help us to develop big data projects. Many great Big data tools and techniques have already been discussed by many researchers.

Designers want to keep away from merchant lock-in and will, in general, flexibility for utility-free apparatuses, just like the likelihood of add-on to their dearest stage. Open source items are the equivalent of bragging, if not the worst degree of documentation profundity, along with considerably more committed help from the network, who are like-minded item engineers and big data specialists, who realize what they need. Having said that, this is the rundown of few hot Big data tools for use in 2019, including the light of fame, extravagance, and convenience.

### 6.1. Apache Hadoop

A long-time boss in the field of large-scale information processing, who is understood for his vast knowledge management skills. This open source data system can continue to operate in prem or cloud

and has very low requirements (Fan and Bifet, 2013). Important Hadoop Benefits such as HDFS-Hadoop DISTRIBUTED File System, which works with large data transfer capacity, Map Download-Model configurable for different big data management, YARN-Hadoop Asset Editor, Hadoop-Required Libraries paste to enable external modules to work with Hadoop.

## 6.2. Apache Spark

The Apache Spark is an option - and in many angles a fan - of the Apache Hadoop. Spark has been used to deal with Hadoop's vulnerabilities and it does this in an incomprehensible way. For example, it can process both cluster information and static information and process it many times faster than a map download. Spark provides memory information for preparation skills, which is a faster route than handling Map Reduce application plates. In addition, Spark works with HDFS, OpenStack and Apache Cassandra, both in the cloud and in the prem, adding another layer of flexibility and data operations for your business's Big Data (Shyam, Kumar, Poornachandran and Soman, 2015).

## 6.3. Apache Cassandra

Apache Cassandra is one of the behind-the-scenes successes of Facebook, as it allows for the processing of information that is being distributed as opposed to a large number of harps worldwide. It performs well under the many outstanding functions available due to its engineering without the sole purpose of disappointment and showcases the novel skills no other NoSQL or social DB has, for example, Unusual Liner Skills, Lack of functionality due to the basic questionnaire used, Stable applications that fall on the harp, Specific include and expulsion of harps in the running group, High adaptability and internal failure and High accessibility functionality (Bifet, 2013).

## 7. THE THINGS NEED TO BE CONSIDER WHEN DECIDE A TOOL FOR BIG DATA

Big data integration tools have the potential to simplify this process a great deal. The features should look for in a big data tool are:

- A lot of connectors: there are many systems and applications in the world. The more pre-built connectors our big data integration tool has, the more time our team will save.
- Open-source: open-source architectures typically provide more flexibility while helping to avoid vendor lock-in; also, the big data ecosystem is made of open source technologies we'd want to use and adopt.
- Portability: it's important, as companies increasingly move to hybrid cloud models, to be able to build our big data integrations once and run them anywhere: on-premises, hybrid and in the cloud.
- Ease of use: big data integration tools should be easy to learn and easy to use with a GUI interface to make visualizing our big data pipelines simpler.
- Transparent pricing: our big data integration tool provider should not ding you for increasing the number of connectors or data volumes.
- Cloud compatibility: our big data integration tool should work natively in a single cloud, multi-cloud, or hybrid cloud environment, be able to run in containers and use serverless computing to minimize the cost of our big data processing and pay for just what we use and not idle servers.
- Integrated data quality and data governance.

## 8. FUTURE OF BIG DATA

While technology is rapidly changing Artificial Intelligence and big data are interconnected and fulfill all the expectations that a company needs, enhancing the application of business data.

Artificial Intelligence and big data have been the epitome of much of this century. These two advanced technologies are seen as a driving force. For the new technology advances, such as real-time use cases and innovations. Artificial Intelligence allows computers to do things that are only the domain of the human. Moreover machine learning creates computers and software that can automatically learn from data to different data sets as needed (Faggella, 2019). Similarly, Digital Learning creates neural networks that is the human brains, which combines and process the data is a similar system. Similarly,



the basic of artificial intelligence is these big data. With the help of these artificial intelligence operations, the smart data analytics has become the key imperative organizations. Improved big data methods create information analysis for accessibility and visibility. Big data algorithms can reveal patterns and trends that facilitate predictive analytics.

Data such as audio, images and text can be found in a wide variety of disciplines such data is obtain as above. Most of the online shoppers already have ultimate in artificial intelligence technology with personalized shopping experience, bots for clients and curated product references. This artificial intelligence technology has the power to predict the age-old aspect of having a streamline operation and how it interacts with customer's future companies that will help us to learn how to go about inventory level in the company. Digital marketing is most effective when content is aptly targeted to the right audience artificial intelligence customize and analyze target email content. It also helps in analyzing the rustic content marketing companies.

According to the study, Artificial Intelligence is seen an important role for content creation. A lot only that it gives us the opportunity to easily access important data. One of the fundamental areas where Artificial intelligence will be the most growth and innovation in automation is the manufacturing spaces (Hackernoon, 2019). Artificial Intelligence also plays an increasingly crucial role in research and development. Its software can perform exercises such as product testing and creation of stimulation. In addition, the company can address issues such as maintenance need and cost companies that adopt Artificial Intelligence technologies to stay ahead of the curve.

Not only in this industry but also in variety of sectors, there are lot of changes to be made in big data. In the foreseeable future. Here are some of these,

- 1 Machine Learning will be the Next Big Thing in Big data: Machine Learning is at the forefront of several of advanced technology trends nowadays, and it is likely to take the place of the future (Brown and Manyika, 2011). According to Ovum, machine learning will be the big data revolution at the forefront. It is not only helping the companies to prepare data but also conduct to predictive analysis through this the company can easily overcome the challenge ahead.
- 2 Big data will be reestablished by quick and actionable data. By the big data research experts, big data is no more. They don't even consist of small quality of data to access or run and larger. One is not always indicated to be much better, soon the big data will be re-established. By quick and actionable data which will help to make the decision at the right moment. By having vast amount of data, it will have a good competitive advantage between the candidates, but also how fast and effectively we can verify and analyze data and filter the actionable result.
- 3 More developers will join the big data revolution: According to the statistics, nearly 60 million of developers are working on big data. They are also use for advanced analytics. This rate is seen by 33% of world's developers (Rasalan, 2009). What's even more amazing is that big data is just starting get bigger and a number of developers are coming up with big data for years to come.

## 9. CONCLUSION

This literature survey examines and discusses the evolution of big data from its inception to its present development. In addition, the research report briefly describes the concepts of big data and other related tools and challenges it faces. In addition, the paper discusses overall understand about big data analysis and how to be an effective tool focusing the future requirements. Big data is an emerging field, and there is still not much research to be done. Currently, Big data is handled by many software names such as Apache Hadoop, Apache Spark and Apache Cassandra. However, the use of such tools is inadequate due to the multiplication of data. In order to fully exploit the potential of big data in the future, extensive research and development of revolutionary technologies must be undertaken. Summarizing, it is essential to be agree with the statement of Geoffrey Moore; "Without big data, you are blind and deaf and in the middle of a freeway (Inc, 2019)."

**REFERENCES**

- Ahmad, I. (2019). *How Much Data Is Generated Every Minute? [Infographic]*. [online] Social Media Today. Available at: <https://www.socialmediatoday.com/news/how-much-data-is-generated-every-minute-infographic-1/525692/>
- Bifet, A., 2013. Mining big data in real time. *Informatica*, 37(1).
- Brown, B., Chui, M. and Manyika, J., (2011). Are you ready for the era of ‘big data’. *McKinsey Quarterly*, 4(1), pp.24-35.
- Faggella, D. (2019). *What is Machine Learning? | Emerj*. [online] Emerj. Available at: <https://emerj.com/ai-glossary-terms/what-is-machine-learning/>.
- Fan, W. and Bifet, A., (2013). Mining big data: current status, and forecast to the future. *ACM SIGKDD explorations newsletter*, 14(2), pp.1-5.
- Gandomi, A. and Haider, M., (2015). Beyond the hype: Big data concepts, methods, and analytics. *International journal of information management*, 35(2), pp.137-144.
- Hackernoon.com. (2019). *AI And Big Data: Two Major Parts of The Digital Future*. Available at: <https://hackernoon.com/ai-and-big-data-two-major-parts-of-the-digital-future-2f9c7c5e813a>.
- Inc, R. (2019). *20 Inspirational Quotes About Data*. RingLead. Available at: <https://www.ringlead.com/blog/20-inspirational-quotes-about-data/>.
- Kakhani, M.K., Kakhani, S. and Biradar, S.R., (2013). Research issues in big data analytics. *International Journal of Application or Innovation in Engineering & Management (IJAIEM)*, 2(8), pp.228-232.
- Loechner, J. (2019). *90% Of Today's Data Created In Two Years*. Mediapost.com. Available at: <https://www.mediapost.com/publications/article/291358/90-of-todays-data-created-in-two-years.html>.
- Rasalan, M., (2009). Global Developer Population and Demographic Study 2009 v1. *Evans Data Report*.
- Shyam, R., HB, B.G., Kumar, S., Poornachandran, P. and Soman, K.P., (2015). Apache spark a big data analytics platform for smart grid. *Procedia Technology*, 21, pp.171-178.

# Concurrent API Communication and the Utilization of Circuit Breaker Design Pattern

Diyanada J. Gunawardena\*

Department of Software Technology, University of Vocational Technology, Ratmalana, Sri Lanka

## ABSTRACT

*The software development industry plays a significant and dependable role in the cutting edge digitalized society. Particularly with the current global pandemic circumstance, the software development industry has rapidly improved. The accuracy of software engineers is an important and viable factor for the software development industry. This research study was carried out as a result of the researcher's observations on technical gaps existing in the concurrent Application Programming Interface (API) communication. Furthermore, proposing a proper solution for the above-mentioned technical gap was one of the aspects of this research study. For the affirmation of the observed technical gap, a questionnaire was distributed among software engineers from various companies in the software industry. To recommend a suitable solution for the technical gap, discussions and the researcher's experience was utilized. Because of the previously mentioned process, all participants were concurred with respect to the conceivable resource wastage because of the monitored technical gap. The participants recommend several options such as pessimistic or optimistic concurrency control (locking), microservices architecture and load balancing and REST architectural style as solutions to overcome the issue. In conclusion, consideration regarding the monitored technical gap were not sufficient in the software industry. Therefore, the researcher introduces an appropriate solution using a circuit breaker design pattern in an application controller layer to deal with concurrent (simultaneous) API transactions.*

**Keywords:** API Communication, API Transaction, Circuit Breaker, Concurrent Communication, Design Pattern.

## 1. INTRODUCTION

An application programming interface (API) is a type of programming interface. An API allows developers to access a business service or an enterprise asset while developing an application. Smartphones, tablets, kiosks, game consoles, connected automobiles, and other devices may all be used to install and access applications (De, 2017). API, in its most fundamental terms, is a mechanism that allows two or more pieces of applications to connect to each other and transfer information. A large portion of the enterprise-level applications still depends there on the execution interaction of the synchronization or objects locks. As a solution for the above-notice proclamation reactor programming has been presented. Be that as it may, the above-mention enterprise-level applications might have an issue. The majority of enterprise-level applications has the ability to perform their transactions asynchronously (parallel communication) in the controller layer (presentation layer). In most basic terms, the controller layer enables their communications in a parallel manner.

Creating threads necessitates the use of the Operating System. API, which is not necessarily a cheap procedure. The standard procedure is to construct a thread pool that may be reused for various activities (Díaz, Wali and Kumar, 2017). Remote calls to software operating in distinct processes, most often on various servers across a network, are prevalent in software systems. Remote calls might fail or linger without a response until a timeout limit is reached, which is one of the major distinctions between in-memory and remote calls. Worse, if you have a large number of calls and an inattentive provider, you may run out of crucial resources, resulting in many systems failure (Fowler, 2014) In a scenario like the above, resource wastage could be happened because of the concurrent (simultaneous) API

---

\* Corresponding Author: E mail - [diyanada@gmail.com](mailto:diyanada@gmail.com)

communication. When the long run of an application, the previously-mentioned synchronize or objects lock process drives the application into the unprocessable (application hang) status.

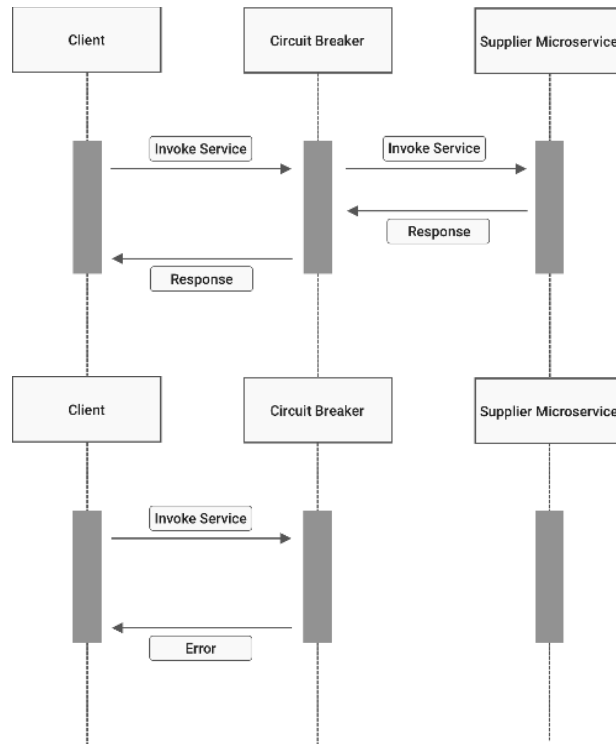

Figure 12: Circuit breaker pattern overview (open and close status) (Davis and Kim, 2019)

The basic idea behind the circuit breaker is very simple. You wrap a protected function call in a circuit breaker object, which monitors for failures. Once the failures reach a certain threshold, the circuit breaker trips, and all further calls to the circuit breaker return with an error, without the protected call being made at all. (Fowler, 2014)

Considering the above-mention points, this research study centers around two aspects. The first one was the software engineers that are associated in the software development industry are considering this sort of resource wastage? What are the methodologies, design patterns and techniques that are utilized? If not, researching an appropriate solution utilizing the fault-tolerant circuit breaker design pattern

**2. PROBLEM STATEMENT**

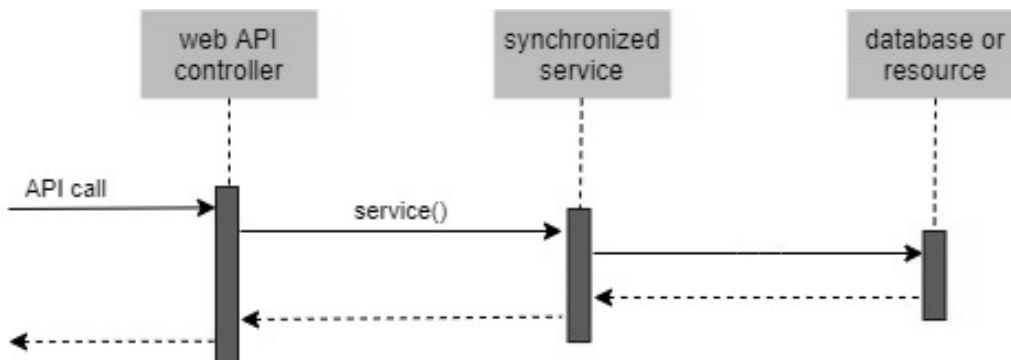

Figure 13 : Single API transaction

A single API transaction has demonstrated (figure 2) below. Single means there was no other transactions between the start to end. The previously mentioned same situation has elaborate with the concurrent (simultaneous) API transactions in the underneath section (figure 3). As indicated by figure 3 second and third API calls needs to delay until the first API call is executed because of the synchronized service method. Moreover, due to the databases transaction locks, API requests need to delay. Whenever the API transactions waiting for the opportunity to execute, a resource wastage could occur. As explained earlier this resource wastage can drive applications into unprocessable status.

Table 18 : Execution time consumption comparison between client-side and server-side

	Expected Delay	Client Execution Time	Server Execution Time
<i>API call 1</i>	1 sec	1 sec	1 sec
<i>API call 2</i>	2 sec	3 sec	2 sec
<i>API call 3</i>	3 sec	6 sec	3 sec

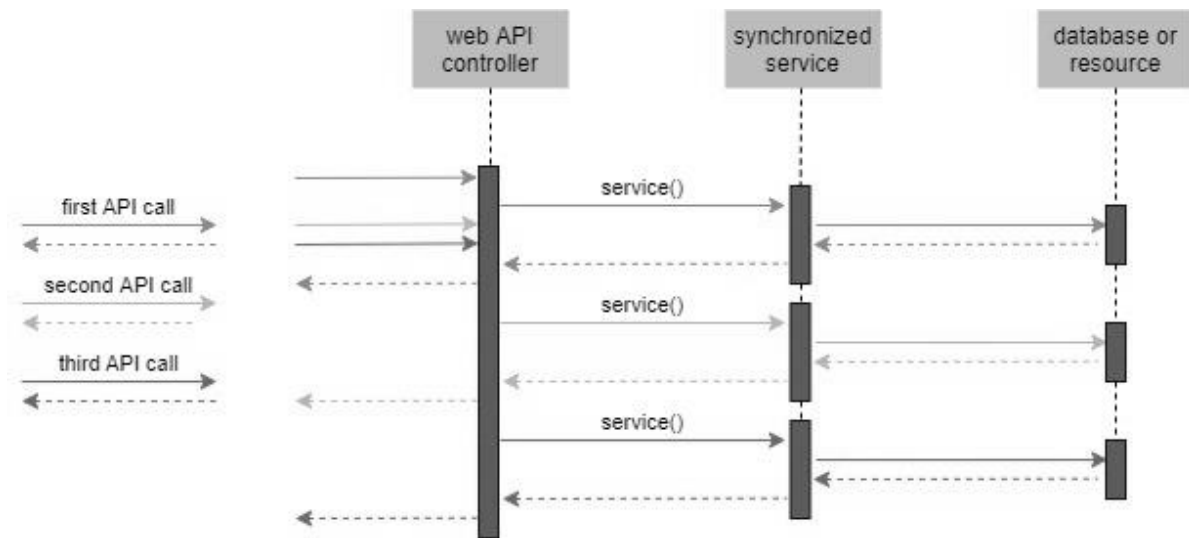

Figure 14 : Concurrent API transaction

### 3. RESEARCH METHODOLOGY

The first aspect of the research study is based on the quantitative research methodology. The collected data through a questionnaire survey conducted among 16 different level software engineers (described in figure 4) associated with the software development industry of Sri Lanka.



Figure 15 : Levels of the profession that participated in the questionnaire

All participants are actively associated with enterprise-level application development (software coding) from different companies. Before the questionnaire start, the researcher has explained the concurrent API transaction using below JAVA code fragments (attached in figure 5 and 6).

```
public static final String URL DELAY = "http://localhost:9090/delay/";

private final RestTemplate restTemplate;

@Override
public void run(String... args) {
    int calls = 10;
    List<Integer> delays = IntStream.rangeClosed(1, calls).boxed()
        .collect(Collectors.toList());

    Instant start = Instant.now();
    delays.parallelStream().map(this::call).collect(Collectors.toList());
    long duration = Duration.between(start, Instant.now()).getSeconds();
    System.out.println("execution time call: " + duration + " for calls: " + calls);
}

@Async
public CompletableFuture<Response> call(Integer delay) {
    String url = URL DELAY + delay;
    Response response = restTemplate.getForObject(url, Response.class);
    return CompletableFuture.completedFuture(response);
}
```

Figure 16: Asynchronous API calls from client-end

```
@GetMapping("delay/{delay}")
public Response delay(@PathVariable Integer delay) throws InterruptedException {
    return SynchronizedService(delay);
}

@Synchronized
private Response SynchronizedService(Integer delay) throws InterruptedException {
    TimeUnit.SECONDS.sleep(delay);
    return new Response(HttpStatus.OK, Boolean.TRUE);
}
```

Figure 17: Asynchronous endpoint and synchronous service of the server-end

To the second aspect (researching an appropriate solution utilizing the fault-tolerant circuit breaker design pattern) of the research study, the researcher has utilized discussion methodology for determining an appropriate solution with all selected software engineers after the problem was explained using the above JAVA code.

#### 4. RESULTS

As mentioned in the methodology section this study is essentially dependent on a questionnaire survey. The summarized consequence of the questionnaire has described below (Figure 7). As indicated by the outcome over 80% of the sample had experience with concurrent API transaction development. Besides, 13% of the sample believe that concurrent API transaction does not devour more resources. Fascinating factor among that, above-mentioned 13% only incorporates minor experienced software (associate) engineers.

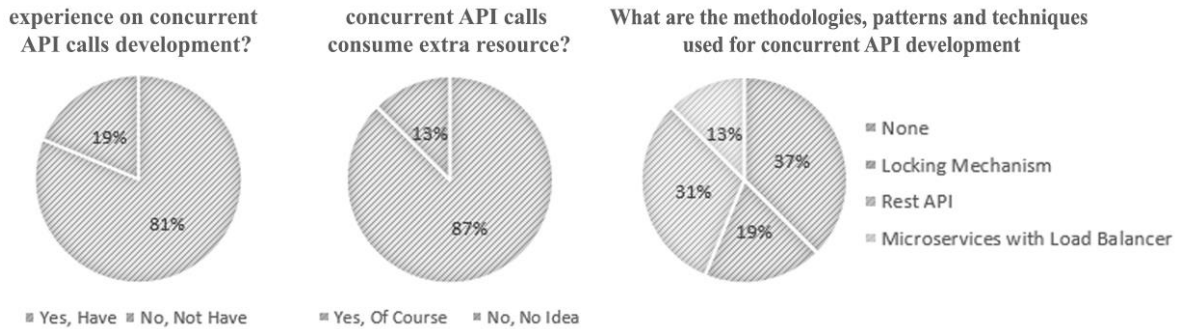

Figure 18 : Results of the questionnaire

Three suggestions were raised from the questionnaire to avoid additional resource consumption. Those are locking mechanism, rest API and micro services with a load balancer. But none of these suggestions does not resolve controller layer congestion (holding to execute). The genuine factor was 37% of the sample does not care about the above-mention resource wastage. Furthermore, according to the questionnaire, 87.5% of the sample does not have thoughts regarding the circuit breaker design pattern and 100% of them not have utilized this circuit breaker design pattern.

The conversations with regards to the circuit breaker design pattern and controller level API transaction congestion has raised several alternatives. Those alternatives were utilized to recommend the fitting solution for avoiding the controller level API transaction congestion in the following segment. Especially in the conversations, the importance of the usage of the retry design pattern with the circuit breaker design pattern was discussed. To protect against partial or whole cascade failures, we utilize a circuit-breaking design pattern. We want to limit/reduce/eliminate traffic to unstable systems so that they don't become overburdened and unable to recover (Posta, 2021).

### 5. RECOMMENDED SOLUTION

As indicated by the investigation carried out due to the questionnaire and the discussions that were held with the sample, there were a possibility of presenting a solution using the circuit breaker design pattern for the additional resource consumption (controller layer congestion) due to concurrent API transactions. The following illustration describes (figure 8) the methodology of the utilization of the circuit breaker design pattern to avoid controller layer API transactions congestion.

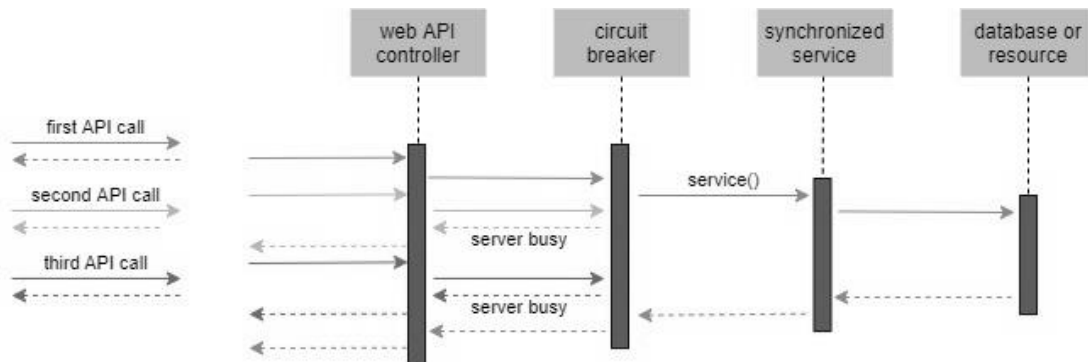

Figure 19: Concurrent API call with controller level circuit breaker

According to the illustration, second and third API transactions does not delay until the first transaction execute. When the circuit breaker is in open status the incoming requests would react with server busy status (503). When considering the entire environment of the API transaction, for a more accurate circumstance the transaction should wrap with the retry mechanism. The following code fragments (figures 9 and 10) has elaborated the real-world coding implementation of the above illustration (figures 8) using JAVA programming language and Spring framework.

```

public static final String URL_DELAY_BREAKER = "http://localhost:9090/delay/breaker/";

private final RestTemplate restTemplate;

@Override
public void run(String... args) {
    int calls = 10;
    List<Integer> delays = IntStream.rangeClosed(1, calls).boxed()
        .collect(Collectors.toList());

    Instant start = Instant.now();
    delays.parallelStream().map(this::breakerCall).collect(Collectors.toList());
    long duration = Duration.between(start, Instant.now()).getSeconds();
    System.out.println("execution time breaker: " + duration + " for calls: " + calls);
}

@Async
public CompletableFuture<Response> breakerCall(Integer delay) {
    String url = URL_DELAY_BREAKER + delay;
    Response response = restTemplate.getForObject(url, Response.class);
    return CompletableFuture.completedFuture(response);
}

```

Figure 20: Client-side code for concurrent API with circuit breaker pattern

```

@Synchronized
private Response synchronisedService(Integer delay) throws InterruptedException {
    TimeUnit.SECONDS.sleep(delay);
    return new Response(HttpStatus.OK, Boolean.TRUE);
}

Lock lock = new ReentrantLock();

@GetMapping("delay/breaker/{delay}")
public Response delayBreaker(@PathVariable Integer delay) throws InterruptedException {
    if (lock.tryLock()) {
        try {
            return synchronisedService(delay);
        }
        finally {
            lock.unlock();
        }
    } else {
        return new Response(HttpStatus.TOO_MANY_REQUESTS, Boolean.FALSE);
    }
}

```

Figure 21: Server-side code for concurrent API with circuit breaker pattern

The following code fragment (figure 11) portrays the recommended appropriate solution with the fault-tolerant approach. One of the best advantages of the circuit breaker design pattern is the fault-tolerant



approach. Utilizing the fault-tolerant approach API communication would proceed without an exception even though the destination service is not functioning.

```

public static final String URL_DELAY_BREAKER = "http://localhost:9090/delay/breaker/";

private final RestTemplate restTemplate;

@Override
public void run(String... args) {
    int calls = 10;
    Instant start;
    List<Integer> delays = IntStream.rangeClosed(1, calls).boxed()
        .collect(Collectors.toList());

    start = Instant.now();
    delays.parallelStream().map(this::fullBreakerCall).collect(Collectors.toList());
    long duration = Duration.between(start, Instant.now()).getSeconds();
    System.out.println("execution time full breaker call: " + duration
        + " for calls: " + calls);
}

@Async
public CompletableFuture<Response> fullBreakerCall(Integer delay) {
    try {
        String url = URL_DELAY_BREAKER + delay;
        Response response = restTemplate.getForObject(url, Response.class);
        return CompletableFuture.completedFuture(response);
    } catch (HttpClientErrorException | HttpServerErrorException ex) {
        if (HttpStatus.TOO_MANY_REQUESTS.equals(ex.getStatusCode())) {
            return CompletableFuture.completedFuture(
                new Response(HttpStatus.TOO_MANY_REQUESTS, Boolean.FALSE));
        } else {
            log.error(ex.getMessage(), ex);
            return CompletableFuture.completedFuture(
                new Response(HttpStatus.INTERNAL_SERVER_ERROR, Boolean.FALSE));
        }
    } catch (RestClientException ex) {
        log.error(ex.getMessage(), ex);
        return CompletableFuture.completedFuture(
            new Response(HttpStatus.INTERNAL_SERVER_ERROR, Boolean.FALSE));
    } catch (Exception ex) {
        log.error(ex.getMessage(), ex);
        return CompletableFuture.completedFuture(
            new Response(HttpStatus.SERVICE_UNAVAILABLE, Boolean.FALSE));
    }
}

```

Figure 22: Client-side code for concurrent API with fault-tolerant circuit breaker pattern

We understand the need of elegantly handling application failures and failure operations as software engineers. Combining the retry and circuit breaker design patterns may yield better results since it gives the program more options in managing failures (Subramanian and Raj, 2019).

## 6. CONCLUSION

As elaborately described in the above sections of this research study the researcher has recognized possible resource wastage (transactions congestion) due to the concurrent API transaction exchanges. Further, according to the results of the questionnaire survey, consideration of the above-mentioned resource wastage was not at a satisfactory level in the software development industry. Suggestions from the participants did not serve an appropriate solution for the above-mentioned resource wastage. The software development industry ought to consider this factor strongly. Besides, the utilization and knowledge of the design patterns are not sufficient in the software development industry.

A solution for the previously mentioned resource wastage was presented in the research study using the circuit breaker design pattern. The recommended solution has two approaches. The first one was a

controller level circuit breaker to handle the concurrent API transactions congestion. The second one has used the same process with the fault-tolerant strategy.

## 7. RECOMMENDATION

Maintaining the accessibility and operability when implementing the recommended solution (both approaches) in the applications should collaborate with the retry design pattern. In other terms, the utilization of the recommended solution should be covered with the retry design pattern. In the fault-tolerance approach of the recommended solution should define the appropriate retry threshold. Otherwise, infinity looping and unpredictable resource wastage could occur due to the API transaction exchange

## REFERENCES

- Ayeva, K. and Kasampalis, S., 2018. Mastering Python Design Patterns - Second Edition. 2nd ed. Birmingham, United Kingdom: Packt Publishing, pp.205 - 206.
- Carnell, J. and Sánchez, I., 2021. Spring Microservices in Action, Second Edition. 2nd ed. Shelter Island, New York: Manning Publications Co. LLC, pp.173 - 175.
- Davis, C. and Kim, G., 2019. Cloud native patterns. 1st ed. Shelter Island, New York: Manning Publications Co.
- De, B., 2017. API Management: An Architect's Guide to Developing and Managing APIs for Your Organization. 1st ed. Bangalore Karnataka India, p.1.
- Díaz, E., Wali, A. and Kumar, S., 2017. Clojure, high performance JVM programming. 1st ed. Packt Publishing, p.229.
- Fowler, M., 2014. bliki: CircuitBreaker. [online] martinowler.com.
- Goetz, B., Peierls, T., Bloch, J., Bowbeer, J., Holmes, D. and Lea, D., 2006. Java Concurrency in Practice. pp.283 - 287.
- Nurkiewicz, T. and Christensen, B., 2016. Reactive programming with RxJava. 1st ed. Sebastopol, California, United States: O'Reilly Media, Inc., pp.1 - 6.
- Posta, C., 2021. Comparing Envoy and Istio Circuit Breaking with Netflix OSS Hystrix.
- Subramanian, H. and Raj, P., 2019. Hands-on RESTful API design patterns and best practices: design, develop, and deploy highly adaptable, scalable, and secure RESTful web APIs. 1st ed. Birmingham, United Kingdom: Packet Publishing, pp.123 - 125.

# Online Management System for Large Scale Pharmacies

M. Pavucsan<sup>\*1</sup>, M.R.R. Banu<sup>1</sup>, M. Gowthami<sup>2</sup>, L. Pradeep Kalansooriya<sup>3</sup>

<sup>1</sup>Department of Software Technology, University of Vocational Technology, Sri Lanka

<sup>2</sup>Department of Multimedia Technology, University of Vocational Technology, Sri Lanka

<sup>3</sup>Department of Computer Science, General Sir John Kotelawala Defence University, Sri Lanka

## ABSTRACT

*Nowadays the technology improves at a top speed. It helps us to make our life easier and more comfortable. As we all know, the medical field is developed and well maintained with the help of different types of systems all over the world. Everyone wants the best medicine to cure and also the easiest way to have them on the door step. The Centralized Pharmacy System is one such system specialized to unite all pharmacies in Sri Lanka together with all the security. This helps the customers to buy their medicines easily on time without any interruptions. There is a home delivery as well as a case on delivery. Not only for customers but also for pharmacists, handling the system and controlling their inventory system and sales and distribution are easier. This System makes the owners and customers feel free to buy and sell products.*

**Keywords:** Home Delivery, Medicine, Pharmacy, Sales and Distribution.

## 1. INTRODUCTION

This project is concerned about the Centralized Pharmacy System, which is going to be a user perfection. The purpose of this project is to unite all the pharmacies in Sri Lanka together to make the customer feel free to buy their medicines on time. The person can order the item which they want and there will be a home delivery and also case on delivery. Still in Sri Lanka most of the pharmacies are maintaining their records by hand. That is the availability of the medicines, their prices, their bills and etc. This type of data records may not have perfect security. Therefore, these data records may have a data loss. Through this project all the pharmacies can have their records perfect and also, they can maintain their own profiles. This system makes them easy to work with.

Centralized Pharmacy is a system which consists of opening an account with the user's name and password, data entry, retrieval and monitoring stocks, sales, customer records, Inventory records, vendor's records, salesmen records and determining the minimum quantity of each drug. String searching techniques also applied in this system. This technique is referring by drug's name, drug's barcode and drug's description. Beside that the system also provides two methods which are quantity and expired date of drugs. This system will always check the date to remind the sales man whether the certain drug's date was expired and also will be triggered to remind the certain drug's quantity was minimized. This will help the administrator to maintain and monitor the drug stocks effectively. (Aisha A-Shibli, Safiya Al-Jaradi, 2017)

The system will have a special service that is to provide a home delivery for the customers at any time even in the quarantine days. (Ashwin Kumar, 2011) Also, case on delivery is available for them. This will help the customers to be relaxed without getting unwanted tension about their health.

Due to the best service of the pharmacy, there will be a very large customer base. Therefore, the quick increase of the customers might make the pharmacist pretty tired of writing the data of the customers. This system will solve this kind problems easily by entering the data of the customers in the system. Meanwhile the pharmacist has to ensure satisfaction in services to keep their records effectively in a reasonable time. (G. Prashanthi, S. Sravani, Saleha Noorie, 2017)

Centralized Pharmacy System deals with managing the medicine stocks and selecting the suitable medicine needed by the customers. The core of the pharmacist profession is to maintain the quality and the subsequent implication on medical monitor and the control in the pharmacy activities. The domain of this project is information technology in health care. Within the growth of the information

---

\* Corresponding Author: E-mail - [smpavucsan@gmail.com](mailto:smpavucsan@gmail.com)

communication technology and the medical technology, the system developers take this opportunity to help the pharmacist to manage the stocks and the customers to take care of their health even in the insufficient situations. (Ashwin Kumar, 2011)

Therefore, the Centralized Pharmacy System will be a very helpful system for all the pharmacists as well as the customers.

## 2. PROBLEM STATEMENTS

Uniting all the pharmacies in Sri Lanka and improving the performance and efficiency of the pharmacies is the major goal of Centralized Pharmacy System. The customers can order their medicines through this system and get them through home delivery and also there will be a case on delivery too.

The following are some of the problems in creating the Centralized Pharmacy System, the number of pharmacies are not accurate, because some pharmacies are not registered under the medical council. Some pharmacies don't maintain the drug details effectively, it is hard to determine the stock balance. Its bit difficult to find some medicine's name and their descriptions.

## 3. AIMS

To unite all the pharmacies together and get the medicines in the easiest way. Easy management and maintenance for all the pharmacists and to make the customers feel free of their health in any situation.

## 4. METHODOLOGY

A methodology is a combination of a logically related method for step-by-step techniques for a successful planning, controlling and delivering of the project. It is scientifically proven that systematic and discipline approach will help the project in development and implementation.

In this system I have used System development life cycle (SDLC) methodology, SDLC is a traditional methodology for developing, maintaining and replacing information system. This methodology consists of different phases that describes the procedures for successful system development. (Boyde.J, 2014)

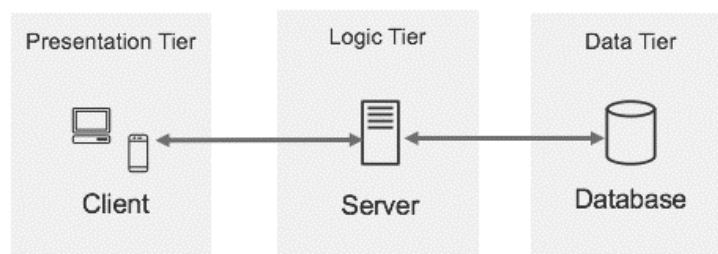

Figure 1: Three Tier Architecture

In this system we are using the concept of three tier architecture. Figure 1 shows the concepts of three tier architecture. One is presentation tier which will be the front-end. The second one is the logic tier which will be the Back End. The last one is the data tier which will be the database in our system. (Halvosen, Hans-Peter, 2021)

The Front End will be created using ReactJS (TypeScript and JavaScript and React strap library and other library). This is one of the popular front-end developments frame work which is used in Facebook. This will help to build rich user interface. The key benefits of ReactJS are speed, flexibility, performance, usability and also mobile app development. These qualities are very important to develop a user-friendly application. (riptutorial.com, 2021)

The back End is Spring Boot 2.0 (Java 8.0). The Spring Boot framework is to reduce overall development time and increase efficiency by having a default setup for unit and integration tests. The database is PostgreSQL which is one of the most advanced open-source relational database system. It is characterized by many features that help developers build applications, administrators to protect data

integrity and help data analyst and data scientist to manage their data regardless of the size of the data set. (Bodnar.J, 2021)

Postman is an API client that makes it easy for developers to create, share, test and document APIs. API testing is a software testing practice that test the APIs directly. (Despa, Valentin, 2021)

The last one is Project compiler. The compiler we are using in this project is Docker which is essentially a toolkit that enables developers to build, deploy, run, update, and stop containers using simple commands and work-saving automation through single API. (Raj, Pethuru, 2021)

## 5. DESIGN AND IMPLEMENTATION

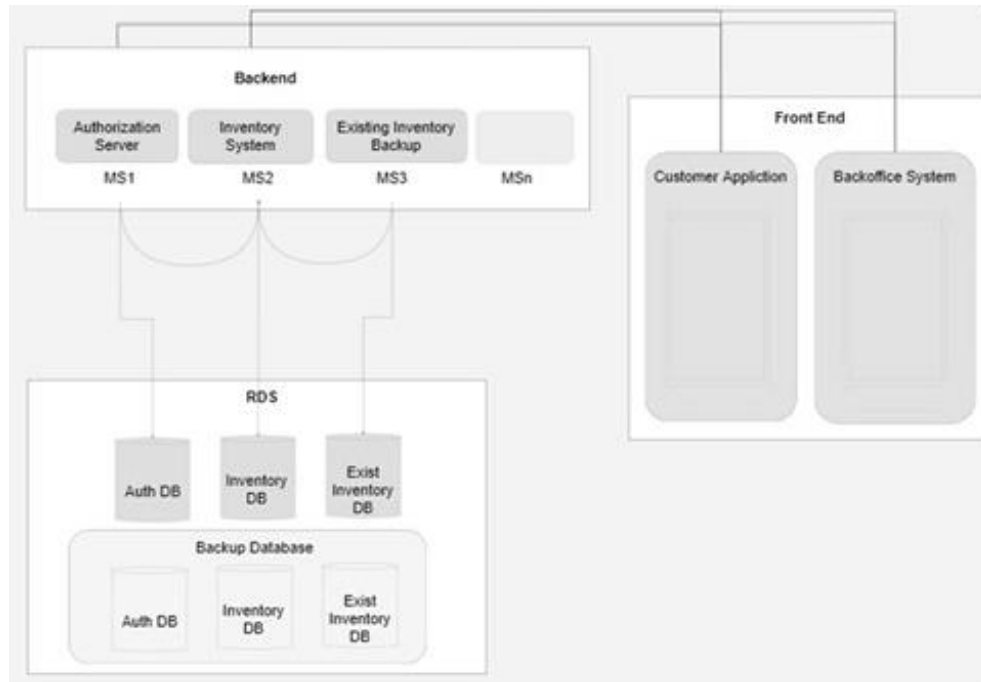

Figure 2: Block Diagram of the Centralized System

The concept of three tier architecture is used in this system. According to the Figure 2 three main parts are playing the major role in the system. They are front-end, back-end, and Rational Database System (RDS).

In the back-end process Micro Services (MS) are connected. The importance of using the MS is we can add any number of services and they will be working independently. Even if a single service is not working the other services will work without any interruptions. They don't dependent on each other.

Here the MS<sub>1</sub> is Authentication Server which is providing user management service under the concept of Role base access control. The next one is MS<sub>2</sub>, this is inventory service which is working under the credential base between each pharmacy. Therefore, every pharmacist can have their private pages. They can control their own inventory. The third one MS<sub>3</sub> which is existing inventory backup. This will have the inventory backups. The last one which is mentioned as MS<sub>n</sub> that is any number of services that can be added. In future we will be adding some more services to update our system. For an example, next we are going to add payment services which will have the credit card payment method and so on. This is the concept for the back-end.

In the front-end there will be two parts. They are customer application and the back-office System. The front-end will be in web, mobile and tab which will have different platforms. Also, in future it will be used in smart watch as well. With the help of back-end API this will be developed.

The last one is the database. Here we are using Relational Database System (RDS). That is PostgreSQL. The database will be separated for each service.

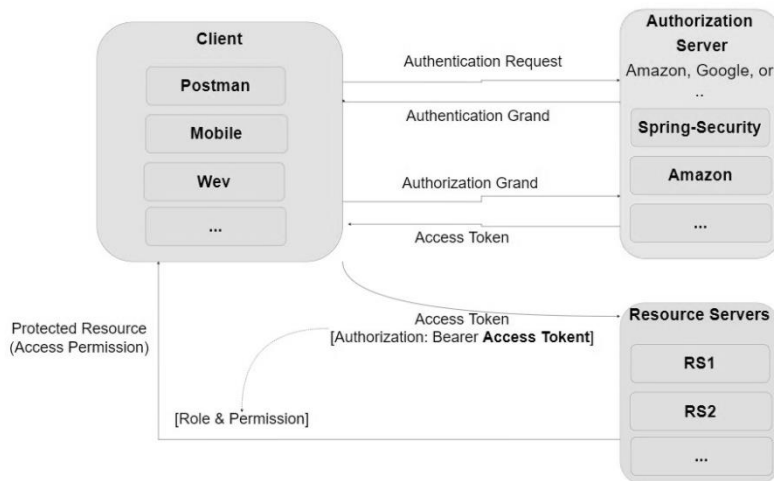

Figure 3: oAuth2 Security Concept

The figure 3 shows the special features of the Centralized Pharmacy System, that is the security concept of the system. Here we are going to use the Token method through Authorization Server. When we Log in to the system the authorization server will send an authentication to access. If the accessibility is NO then it returns. If the accessibility is YES then the server will provide an access token to get into the micro service. The Micro service call and the access token will access the micro service when the MS grand permission. If not, the access will be denied. Also, there are two more token available in the concept, they are expired token and reverse token. The Expired token will have the access until the date which is given to Log in without entering username and password which is already accessed.

The other token is Reverse token which will work after expire date. The system will ask to login again with the Username and Password to confirm whether the authorized person is accessing the system or not. This is how the security concept will work. This concept is used in Google, Facebook, Windows Live, and GitHub and so on. (Parecki, 2012)

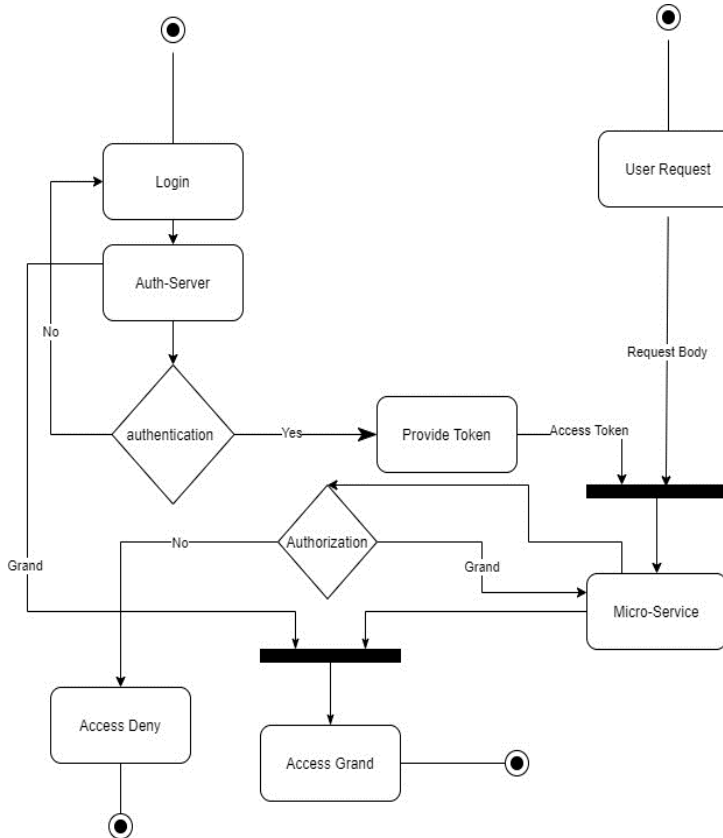

Figure 4: oAuth2 Security Concept Activity Diagram

## 6. EXPECTED RESULTS

The system will provide an easily accessible way to get registered into the system for the pharmacists. The inventory system will be maintained well. The best customer satisfaction in purchasing their drugs, an easy way to identify the drugs which the customer

need. The details of the vendors and the salesmen can be identified easily. The system will reduce the human errors.

## 7. CONCLUSION

The “Centralized Pharmacy System” is presented in the paper to overcome existing problems, and assist in Pharmacy management. This system provides quick and easy access to general users. Now a days everyone is using mobile phones to do everything in their present life. So, the user interface for the system will support for the Mobiles. It can protect the information which we insert. This system will help the admin to login and control the inventory management. This System will help both the customers and pharmacists. The security concept will be the best part in this system which will secure all the details which we insert to access the System. Overall, this system will be the good solution to upcoming pharmacy applications.

## REFERENCES

- Aaisha A-Shibli, Safiya Al-Jaradi, 2017. Electronic Pharmacy System. International Journal of Computation and Applied Science, 3(3), pp. 284-291.
- Ashwin Kumar, U. K. A. K., 2011. Online Pharmacy - An E-Strategy for medication. International Journal of pharmaceutical Frontier Research, pp. 146-158.
- Bodnar.J, 2021. Spring Boot. s.l.:Jan Bodnar.
- Boyde.J, 2014. A Down-To-Earth Guide To SDLC Project Management (2nd Edition): Getting your system / software development life cycle project successfully across the line using PMBOK adaptivel. s.l.:Joshua Boyde.
- Despa, Valentin, 2021. Postman Quick Reference Guide Documentation. 1.8.0 ed. s.l.:Valentin Despa.
- G. Prashanthi, S. Sravani, Saleha Noorie, 2017. A revivew on Online Pharmacy. IOSR Journal of Pharmacy and Biological Sciences (IOSR-JPBS), 12(3), pp. 32-34.
- Halvosen, Hans-Peter, 2021. 3 Tier Architecture. Norway: Ramkumar.
- Parecki, A., 2012. An Introduction to OAuth 2. 1st ed. s.l.:Aaron Parecki.
- Raj, Pethuru, 2021. Learnig Docker. 1st ed. s.l.:Pethuru Raj.
- riptutorial.com, 2021. ReactJs. [Online] Available at: <https://riptutorial.com/reactjs> [Accessed 2021].

# Use of GIS Technology as a Tool for Locating Public Libraries

S.C.D. Siyambalapitiya\*<sup>1</sup>, R. C. Gamage<sup>2</sup>

<sup>1</sup>University College of Kuliyaipitiya, Sri Lanka

<sup>2</sup>National Institute of Library and Information Science, University of Colombo, Sri Lanka

## ABSTRACT

*Due to its versatile nature, GIS provides a vast platform for the managers in decision making. GIS can be used in the management of public libraries too. Public libraries play a major role in the development process by upgrading educational levels in general and the literacy level in particular. Sri Lanka has 1199 public libraries. However, the public libraries must be correctly located in order to cater to the society at large with the notion that no any segment of the society could be marginalized in terms of access to information, and each citizen has the right to access information without being discriminated. It is believed that public libraries are publicly utilized when they are located in the correct places wherever deserved. This paper is aimed at analysing some key literature findings which forms only a part of a bigger research area, addressing the question whether public libraries are accessible to the population in local authority domain areas of the Uva province. The study fulfilled this knowledge vacuum by using GIS technology in locating public libraries. The Uva province was selected for the study considering its socio-economic status with the minimum provincial population in education attainment, low literacy rate and poverty incidence. Through this study, the service areas of public libraries in the Uva Province were identified and this will help most of the users to use this service qualitatively.*

**Keywords:** GIS, Library Management, Location-Allocation, Public Libraries.

## 1. INTRODUCTION

One of the smartest ways of assigning locations for libraries is by using the merits of GIS technology. Geographic Information System (GIS) is a computer-based information system based which enable digitally represent and analyse geospatial and geographic data (Bhatta, 2011). There are many definitions produced by many authors and all of them are correct in an appropriate context. However, there are two definitions which are matching to the present study. As per the Rhind (1989) GIS is a system consisting of hardware, software, and procedure which are designed to support the capture, management, manipulation, analysis, modelling and display of spatially referenced data for solving complex planning and management problems” as cited as (Lo & Yeung, 2007) while Burrough (1986) defines GIS in a similar manner but to address a particular set of purpose as cited by (Bhatta, 2011).

A dictum is that an estimate of 80% of all governmental data having a geographic component and public libraries too share this same character (Koontz, 2005). Therefore, GIS can be effectively used in research regarding assigning locations for libraries as appropriate. As per the Burnett, Jaeger & Thompson, 2008 as cited by (Adkins, et al., 2014) information access can be divided into three categories as physical, intellectual, and social. Accordingly, public library outlets provide the physical access and this in fact determines whether a user gains access. IFLA (2010) too highlights the physical accessibility as a major concern over the successful delivery of public library services. Even if library services are of high quality there is no use if not accessible without locational difficulties. Therefore, location is an important factor which largely determines the effective utilization of public libraries that are funded by public money.

However, in Sri Lanka, service areas of public libraries is the geographical area inside the respective local authority and there are several public libraries lies within the same local authority. This leads to an underutilization of public libraries as well as over utilisation due to the overlapping of service areas. Further, in Sri Lanka the technology of GIS has not been used previously in demarcating library service areas. Hence, the purpose of this paper is to offer key literature findings with regard to use of GIS

---

\* Corresponding author: Email: [Deshani\\_siyambalapitiya@yahoo.com.au](mailto:Deshani_siyambalapitiya@yahoo.com.au)



technology as a tool of public library location decision. Hence, the basic research question considered in this paper is ‘what is the suitable method in GIS to demarcate the service areas of public libraries to serve public at an optimum level?’

**2. RESEARCH AIM AND OBJECTIVES**

The aim of this research is to introduce a model that effectively allocates locations for public libraries using GIS technology so that the majority of the communities can be better served in terms of information access. This essentially requires determining the physical accessibility to the public libraries in local authority domain areas and identify the literature with regard to spatial distribution of public libraries. The main objective of this study was to identify a most suitable method that can be used to locate public libraries and associated neighborhood.

**3. RESEARCH METHODOLOGY**

A literature review is systematic way of collecting and synthesizing previous research (Baumeister & Leary, 1997; Tranfield, Denyer, & Smart, 2003). Therefore, an effective literature review will create a rigid foundation in progression of knowledge and enable development of theories (Webster & Watson, 2002). A research question can be addressed with much power by the integration of findings of many other empirical studies. (Hannah Snyder, 2019). This study conducted a comprehensive and systematic literature survey based on a review protocol which is consisting of three main stages namely planning, conducting and reporting the review as described by Xiao & Watson, 2019.

The review was planned by developing a review protocol and formulating a research question. This literature survey was consisting of searching the literature at the outset, screening for inclusions /exclusions criterion, assessing the quality and extracting, analysing and synthesizing data at the end. The latest literature findings have been accessed using electronic databases available in UGC consortia such as EMERALD, WILEY ONLINE and SAGE and Google Scholar. Keywords were used for the search which were derived from the research question with BOOLEAN operators. Apart from electronic databases, The Library Review being the official journal of Sri Lanka Library Association was searched. In addition, text books on library science and GIS were read. Further, institutional repositories such as in the Department of Census and statistics, Central Bank were also investigated.

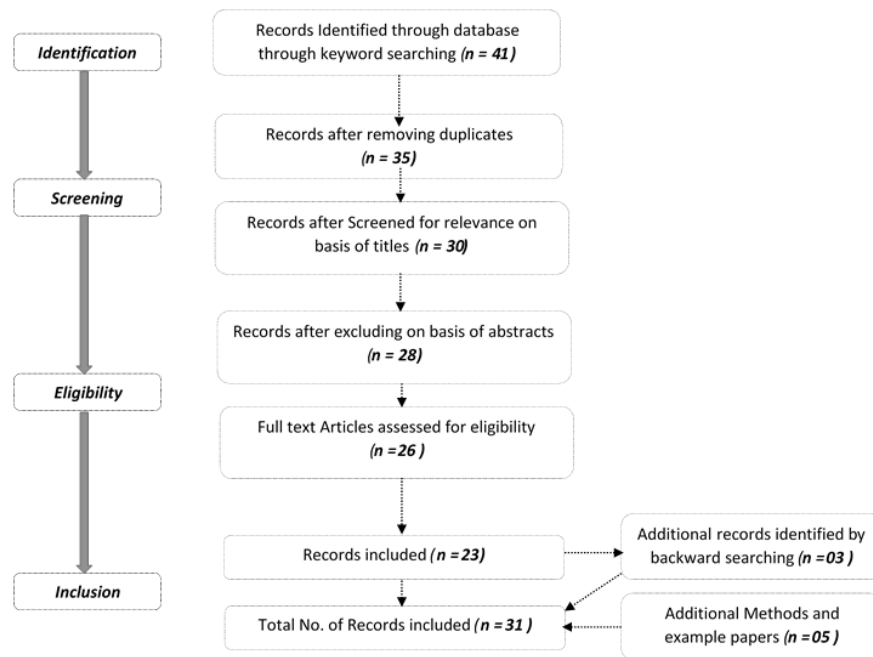

Figure 01: Summary of the Process of Literature Survey

After preparation of the master list of references, inclusions and exclusion were identified by reading the abstracts. Quality was emphasized by referring to the methodologies of the studies. Since most of

the research articles were obtained from recognised journals dedicated for library science, a need to assess the quality did not arise. As the final stage synthesized information was reported. Summary of the process of literature survey is shown in Figure 1.

#### 4. FINDINGS AND DISCUSSION

In 2010 Bishop and Mandel identified two categories of library research types that used GIS as use of GIS in managing library facilities and collections and analysis of library service area using GIS based on two main library databases namely, Library Literature and Information Full Text and Library, Information Science and Technology Abstracts (LISTA). Therefore, findings of this literature survey were summarized based on above two categories and visualized in a tabular form to enable the researchers to go through very conveniently and to provide background information in prior approach to the core of the study.

Use of location-allocation model in service area analysis; the core literature of this study was described in details next to the summary table of findings & discussion in two categories of research types that used GIS in LIS

##### 4.1 Use of Gis in Managing Library Facilities and Collections

Table 01: Summary of findings & discussion in two categories of research types that used GIS in LIS

Ref. No.	Author	Findings	Further Research
1)	Alan D. Jones (1993)	Identified active and inactive users by evaluation of library services and mapping circulation patterns.	Linking the circulation patterns with census data at an aggregated level to identify the needs of the local population.
2)	David Deckelbaum (1999)	Described what a GIS is and its implications for incorporation into a library environment	Standards for geospatial metadata
3)	Elizabeth M LaRue (2004)	Identified the population served by the library and collection type based on the mapped demographics of populations associated with the public libraries.	Incorporating results of GIS analyses in collection purchasing decisions
4)	Jingfeng Xia (2004)	Incorporation of GIS to analyze data relating to daily operations of libraries.	To integrate RFID with GIS.
5)	Jingfeng Xia (2005)	Analysed and presented spatial data of collection locations dynamically in maps and introduced a GIS item-locating system.	Integrating GIS item-locating system into current online catalogue system enabling users to have search results in both textual display and visual demonstration.
6)	Sedighi (2008)	Demonstrated the use of GIS in cataloguing library documents.	Use of customization features of GIS other than the editing and updating to provide access to the available data as per the requirements and to fill the research gaps in different geographic regions

7)	Lauren H. Mandel (2010)	Introduced an open source GIS called “Mapwindow” to analyze and display library usage patterns.	Use of GIS as tools in evaluation of library facility, research in in-library use and valuation and justification of library.
8)	Bradly Bishop (2011)	Revealed the ability of GIS to convey information other than the other means and the ability in spatial analysis of library services	Promotion of experimenting using open source GIS products and applications as additional research tools among LIS researchers, practitioners and stakeholder groups
9)	Ann L. Holstein (2015)	Capture information regarding geographic needs of their respective campuses	Standards for geospatial metadata

#### 4.2 Analysis Of Library Service Area Using Gis

Ref. No.	Author	Findings	Further Research
1)	C.M Koontz (2005)	Developed a web based Public Library Geographic Database which contains all public library data in USA including user data.	Library planning in future.
2)	Japson & Gong, 2005	Investigated the relationship between public library use and associated demographics using theissen polygons.	Improving the use of library branches with the assistance of GIS.
3)	Preiser & Wang (2006)	Analyzed the branch library performance by delineation of service area by geocoding the location of active users based on their home addresses.	Incorporating GIS in master plans for library facility management as a rational decision-making tool
4)	Hertel & Sprague (2007)	Used GIS to analyze the population or demographic characters for establishing two branches for Boise Public library in Boise, the capital of Idaho called west and east branch respectively using buffer zones.	Analysis of demographics of will allow to critical analysis of collection of the new libraries and quantitatively and visually provides methods for prioritize resource allocations future.
5)	Abazari, Babalhaveaji, & Jahangirifard (2012)	Examined the locations of existing public libraries in four regions of Tehran in order to find more suitable locations for new libraries to be constructed by considering the terrain, distance etc. to find appropriate locations other than the population demographics.	Recommended to maintain a minimum distance of 1600m between two libraries in order to avoid overlapping of service areas.
6)	Adkins, Haggerty, & Haggerty, (2014)	Identified the patron base of two branch libraries using buffer zones.	Incorporating census tract-level data to determine the accessibility of poor.

### 4.3 Service Area Analysis Using Location Allocation Model

There are key customer markets such as Consumer markets, Business markets, Global markets and Nonprofit and Governmental markets which are physical places where buyers and sellers interact and transact over a particular product or product class (Kotler, Keller, Koshy, & Jha, 2013). Libraries fall in to the category of nonprofit and governmental markets simultaneously. Further a market is a system in which manages profitable customer relationships with the aim to create value for customers and capture value from customers and the marketing process includes understanding the marketplace and expectations of customer, designing of a marketing strategy based on the customers' expectations, constructing a marketing program delivering higher values, build profitable relationship and make the customer delightful and finally capture value from customers to create profits and customer equity. (Kotler, Armstrong, Agnihotri, & UL Haque, 2010). When considering the all above marketing processes, operations inside a library each resembles the same. In this case marketers are the library staff and customers are the patrons.

The geographic area that most of users can be captured is the market place of a library. (Koontz & Jue, 2000). In turn this is the service area owned by the public library. The public library services should be adapted accordingly to the different needs of communities in both urban and rural areas since needs and expectations will change with time and this adaptation will have to carry on continuously (IFLA, 2010). Since public libraries are places for serving public there is a possible challenge facing by libraries to know the public base and types of services and collections will best fit the expectations of associated public (Hertel & Sprague, 2007).

Authors have adopted several methods to demarcate public library service areas in order to analyze the service areas of public libraries and Koontz & Jue, (2000) described five ways to determine the library market/service area as listed below.

1. Assigning each library, a definite number of census tract or block group.
2. Demarcating the service area of a library through overlay of zip code boundaries based on customer/user addresses.
3. Determine the service area of a library by assign a certain mile radius to be served.
4. Determining actual service area by geocoding user address data.
5. Determining service area by assigning equal quotas of the population to the nearest existing library by the modeling technique "location-allocation".

Location-Allocation model can be used to form structural form of services of facilities to demand optimally and this model help spatial planners to choose optimal locations of public facilities and to plan for new facilities and as well as to evaluate and improve the efficiency of prevailing location decisions (Tali, Malik, Divya, Nusrath, & Mahalingam, 2017). Public facilities such as schools, hospitals, libraries, fire stations, and emergency response services (ERS) centers will be able to provide services of high quality to the community at a low cost if they are established in appropriate locations. Location-Allocation model simultaneously locate facilities and allocate demand point to the located facilities (ESRI, 2019).

To work with Location-Allocation model there are some data layers needed as Network Analyst extension in Arc GIS, a network dataset, a demand point feature class and a facility feature class (Schietzelt & Densham, 2003). When solving a location-allocation problem there are two parameters to be predetermined. They are location-allocation problem type and impedance cut-off. There are seven location-allocation problem type namely; minimize impedance, maximize coverage, minimize facilities, maximize capacitated coverage, maximize attendance, maximize market share and target market share (ESRI, 2019). For studies related public facilities mostly used problem type is maximizing coverage (Buzai, 2013) & (Tali, Malik, Divya, Nusrath, & Mahalingam, 2017). Maximize coverage chooses the maximum number of demand points as far as possible within the given impedance cutoff (ESRI, 2019). Largest amount of demand points will remain assigned within these surfaces (Buzai, 2013).

$$\text{Maximize } \{F = \sum_{i \in I} a_i x_i\} \quad (\text{Eq:01})$$

I is the group of demand points (indexed by  $i$ ) and  $a_i$  is the population in the demand node  $i$  and  $x_i$  are 1 if the center of demand  $i$  is located inside the area of coverage ( $x_i \leq R$ ) and 0 in a contrary case.  $R$  is the coverage ratio prefixed for the supply points (Buzai, 2013). As per the Shia, (2003) as cited by (Abazari, Babalhaveaji, & Jahangirifard, 2012), the public library is a democratic place responsible to serve all the people in the society with a book and to fulfill this responsibility, location of the library in terms of distance and time is a main condition that should be satisfied in order serve maximum people in charge of books. Therefore, maximum coverage model of the location allocation best suited for the current study.

The other important factor is the impedance cut-off which specifies the network cost attribute used to define the traversal cost along the elements of the network in terms of time (minutes) or distance (meters) (ESRI, 2019). Considering the decision-making requirement type of impedance cut off can be selected. Determining library market areas is done by assigning equal proportions of populations to the nearest facility (Koontz & Jue, 2000). According to Hertel & Sprague, (2007) many libraries assign a one-mile radius (1600m) for libraries in urban areas and two mile radius (3200m) for libraries outside the urban area.

In the primary research service areas of public libraries in UVA province were demarcated using the location-allocation model.

## 5. CONCLUSION

Most of the studies have been carried out in various countries to analyze public library service areas and associated Population demographics using several approaches to demarcate the service areas. Location –Allocation model is one of the best methods to demarcate the service areas. However, for the 1199 public libraries in Sri Lanka the service areas are the domain area inside the local authority from which the public library is governed. Therefore, this literature survey has provided a solid framework for the successful use of location-allocation model in GIS for demarcating service areas by the public libraries in Sri Lanka.

## 6. SIGNIFICANCE OF THE STUDY

The primary research investigated the present status of public library system in the Uva province and provided a strong basement upon which the development of the Uva province could be built upon. Further, this study has been carried inside a GIS framework which is novel to studies in Library and Information Science in Sri Lanka and at the same time this study reveals the versatile nature of GIS in the discipline of Library and Information Science. Therefore, this study will be a turning point in the discipline of Sri Lankan LIS being the first attempt to using GIS in LIS.

## REFERENCES

- Abazari, Z., Babalhaveaji, F. & Jahangirifard, B., 2012. GIS- Based evaluation of public libraries locations for more sustainable building site selection (An Iranian experience). Helsinki, IFLA.
- Adkins, D. K., Haggerty, K. C. & Haggerty, T. M., 2014. *The influenc of demographics on new public library facility*. s.l., Wiley Online, pp. 1-8.
- Baumeister & Learly, 1997. Writing Narrative literature reviews. *Review of general Psychology*, Volume 1, pp. 311-320.
- Bhatta, B., 2011. *Remote Sensing and GIS*. 2nd ed. New Delhi: Oxford University Press.
- Bishop, B. W. & Mandel, L. H., 2010. Utilizing Geographic Information Systems (GIS) in library research. *Library Hi Tech*, 28(4), pp. 536-547.
- Bishop, B. W., Mandel, L. H. & McClure, C. R., 2011. Geographic Information Systems (GIS)in Public library Assessment. *Information Science Faculty Publications*.

- Buzai, G., 2013. Location-Allocation models applied to urban public services. Spatial analysis of primary health care centers in the city of Lujan, Argentina.. *Hunagrian Geographical Bulletin* , 62(4), pp. 387-408.
- Deckelbaum, D., 1999. GIS in Libraries: An overview of concepts and concerns, *Issues in Science and technology librarianship*.
- ESRI, 2019. *Location-allocation analysis*. [Online] Available at: <http://desktop.arcgis.com/en/arcmap/latest/extensions/network-analyst/location-allocation.html>
- Hannah, S., 2019. Literature review as a research methodology; An overview and guidelines. *Journal of Business Research*, Volume 104, pp. 333-339.
- Hertel, K. & Sprague, N., 2007. GIS and census data: tools for library planning. *Library Hi Tech*, 25(2), pp. 246-259.
- Holstein, A. L., 2015. Geographic Information and Technologies in Academic Libraries: An ARL Survey of service and support. *Information Technology and Libraries* .
- IFLA, 2010. *The Public Library Service*. Hague: Internation Federation of Library Associations and Instutions.
- Japson, A. C. & Gong, H., 2005. A Neighborhood analysis of public library use in New York City. *Library Quarterly*, 75(4), pp. 446-463.
- Jones, A. D., 1993. Where do all the good books go? Geographic information systems and the local library. *The Australian Library Journal*, 42(4), pp. 241-249.
- Koontz, C. & Jue, D. K., 2000. Use of New Technologie for better library management: GIS (Geographic Information SYstem Software)and PDAs (Personal Digital Data collectors).. Jerusalem, IFLA.
- Koontz, C. M., 2005. Serving Maps of Public Library Data over the Internet ([www.geolib.org/PLGDB.cfm](http://www.geolib.org/PLGDB.cfm)). *Library Hi Tech News*, 22(1), pp. 23-26.
- Kotler, P., Armstrong, G., Agnihotri, P. Y. & UL Haque, E., 2010. *Principles of Marketing : A South Asian Perspective*. 13 ed. New delhi: Dorling and Kindersley.
- Kotler, P., Keller, K. L., Koshy, A. & Jha, M., 2013. *Marketing: A south Asian Perspective*. 14 ed. New Delhi: Dorling Kindersley.
- LaRue, E. M., 2004. Using GIS to establish a public library consumer health collection.. *Biomed Digital Library* , 1(3).
- Lo, C. P. & Yeung, A. K., 2007. *Concepts and Techniques of geographic information systems*. 2 ed. New Jersey: Pearson Education.
- Mandel, L. H., 2010. Geographic Information Systems: Tools for Displaying In-Library Use Data. *Information Technology and Libraries*, pp. 47-52.
- Preiser, W. F. E. & Wang, X., 2006. Assessing library performance with GIS and building evaluation methods. *New Library World*, 107(1224/1225), pp. 193-217.
- Schietzelt, T. H. & Densham, P. J., 2003. *Location Allocation in GIS*. [Online] Available at: [web.pdx.edu/~jduh/courses/geog492w11/Week8a.pdf](http://web.pdx.edu/~jduh/courses/geog492w11/Week8a.pdf)
- Sedighi, M. E., 2008. Use of geographical information system (GIS) in the cataloging of documents: A case study of earth quake document collection. *Library Hi tech*, 26(3), pp. 454 - 465.
- Tali, J. A. et al., 2017. Location-Allocation model applied to urban public services: Spatial analysis of fire staions in Mysore urban area Karnataka, India. *International Journal of Advanced Research and Development*, 2(5), pp. 795-801.
- Tranfield, D., Denyer, D. & Smart, P., 2003. Towards a methodology for developing evidence-informed management knowledge by means of systematic review. *British Journal of Management*, Volume 14, pp. 207-222.
- Webster & Watson, 2002. Analysing the past to prepare for the future: Writing a Literature review. *Management Information Systems Quarterly*, Volume 26, p. 3.

- Xia, J., 2004. Using GIS to Measure In-Library Book-Use Behavior. *Information and Technology and Libraries*, pp. 184-191.
- Xia, J., 2005. Locating Library Items by GIS Technology. *Collection Management* , 30(1), pp. 63-72.
- Xiao, Y. & Watson, M., 2019. Guidance on Conducting a Systematic Literature Review. *Journal of Planning Education Research*, 39(i), pp. 93-112.

**HARNESSING THE OPPORTUNITIES IN HOSPITALITY INDUSTRY  
THROUGH ADVANCED TECHNOLOGIES**



# Effectiveness of Digital Media Platforms in Promoting and Marketing Sri Lanka Tourism

R.P.S.K.Rathnaweera\*, B.V.D.R.Dharmarathna, B.M.T.D.Jayasekara

Department of Management Studies, University of Vocational Technology, Sri Lanka

## ABSTRACT

Tourism takes an important place in Sri Lanka's foreign exchange. In 2019 expected number of foreigners was 3 million, but it was 1.9 million, and in 2020 it fell again. Because after the Easter attack and then Covid - 19 pandemic, the tourism sector of Sri Lanka has fallen because they are fearful of being here, and some foreign countries banned Sri Lanka as a threatened country. Sri Lanka also restricts for months to foreigners. However, those problems can be solved by marketing positive things about Sri Lanka. The main objective of this research is to promote Sri Lanka tourism through digital marketing effectively and find the most effective digital media platform. However, this marketing should be done online because tourists are remote from us, and this should be long-term because they are restricted from visiting Sri Lanka. However, most marketers doing digital marketing by using one or two platforms. So using more platforms and connect them together can be very strategic. As the result lot of audience gather around us by publishing tourism related contents and Instagram is the most effective platform to promote tourism according to analyzed data in this project.

**Keywords:** Covid – 19, Digital Marketing, Platforms, Sri Lanka, Tourism.

## 1. INTRODUCTION

Tourism is regarded as a significant economic activity around the world because of its direct economic impact as well as considerable indirect and induced effects. According to the World Travel and Tourism Council, the travel and tourism industry is one of the most important economic sectors in the world, accounting for 10.4% of global GDP and 313 million jobs, or 9.9% of overall employment in 2017. Tourism is Sri Lanka's third-largest export earner, and the industry has experienced exceptional growth in the last five years.

Sri Lanka had been in lockdown for a while due of the Covid-19 pandemic. According to the latest data given by the Sri Lanka Tourism Development Authority (S.L.T.D.A.), visitor arrivals in Sri Lanka plummeted by 70.8 % from a year earlier to 71,370 in March 2020, due to the COVID-19 issue.

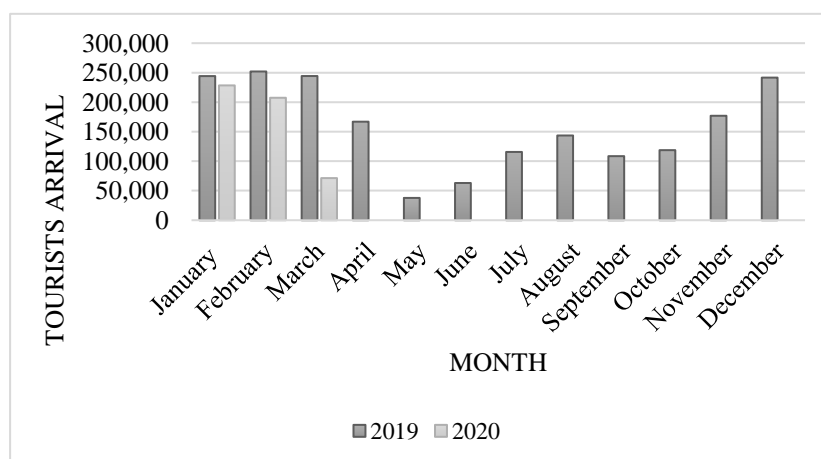

Figure 1: Tourism Arrival data in 2020 & 2019

\* Corresponding Author: E-mail - sndunkavinda@gmail.com

Tourist arrivals fell for the third month in a row in March. Arrivals decreased by 6.5 % in January to 228,434, and by 17.7 % in February to 207,507. Following the Easter Sunday terror attacks in April 2019, Sri Lanka has seen a monthly fall in tourist arrivals compared to 2018 and 2019.

Figure 1 shows how tourism arrivals were decreased due to the Covid – 19 in 2020 than 2019 and how tourism attraction decreased in May & June of 2019 because of the Easter Sunday attack.

Table 1: Digital Marketing Usage

<b>Total Population – 21.37 Million</b>		
<b>Mobile Phone Connection</b>	<b>Internet Users</b>	<b>Active Social Media Users</b>
<b>31.80 million</b>	10.10 million	6.40 million

The main idea is to proper marketing to solve those problems in Online Marketing / Digital marketing. The above table shows how many people were used digital marketing in past years because the new generation finds products and services through digital media whether they can buy online or physically. So digital marketing is the best way to promote tourism in Sri Lanka.

Digital Media platforms, such as Facebook, Instagram, Pinterest, Linked In, Twitter, YouTube, and Website, are used in that project.

## **2. LITERATURE REVIEW**

Several authors (Buhalis, 2003; Buhalis & Law, 2008) believe that the Internet is a potent and successful tourism marketing instrument. Maintaining a corporate website is critical for the maintenance of relationships created between organizations, through establishing relationships with the public, particularly with customers, and so capturing a wider market segment (Law et al., 2010).

Traditional Marketing involves collecting data through market research and then analyzing the same to help understand the audiences better. The digital nature of Internet technology provides a comprehensive and detailed insight into the characteristics of consumers and their behaviour in the electronic environment. (Batinić, 2015) This information has transformed the way business decisions are being made. The impact of each marketing initiative can be studied in real-time along with being customized for every customer.

Millions of people experience the natural environment every year, and the size of this movement gets disturbed or damaged inevitably visited the site. While directly or indirectly attributable to their activities, this damage to the tourist, whether the actual behaviour responsible for the major negative effects on natural activities and related such as the construction and development of infrastructure and facilities are often unclear (Deng et al., 2002).

## **3. OBJECTIVES**

### **3.1. Broad Objective**

- To promote Sri Lanka tourism through digital marketing effectively.

### **3.2. Specific Objective**

- To find the most effective digital platform based on the type of content.

## **4. METHODOLOGY OF THE STUDY**

The main problem is Covid - 19 pandemic in Sri Lanka. It affected the economy of Sri Lanka from the Foreign Income in tourism, apparel and etc. The best way to promote it by using Digital Marketing because it is easiest and strategic way for reach to the audience. Promoting Sri Lanka tourism industry to local people is the solution for that and it may be a help to maintain industry until foreigners are free

to visit here. The problem is fallen down tourism after COVID-19 and Easter Attack, and the need is to Promote Sri Lanka tourism through Digital Marketing. Several Digital Media platforms were created in this project. The brand name is "Ceylon Sri Lanka." Word Press developed website (www.ceylonsrilanka.com) is the main thing and then developed other platforms such as Facebook, Instagram, Twitter, etc.

Before creating contents to that platforms, it is needed to know the audience's wants, needs, and requirements related to tourism and travel. Then the contents can share and promote to the right audience at the right time. Both primary and secondary data collection methods were used in this project. Questionnaire is the primary data collection method in this. This questionnaire prepared by using Google forms and link of this were shared on the travel related Facebook groups and among friends. 100 samples were collected and analyze the behaviors, needs and wants, popular destinations, reservation methods of the audience by using this. As the secondary data, annual reports of tourism board and other related articles that shows the analysis of tourism arrivals in past months were used in this project.

After analyzing the data of the Google form and contents were published to the all the platforms and several strategies in the platforms when publishing contents are used to reach and engage more audience. The marketing channels have to categorize according to a few segments, such as generation, level of society, internet users, employees, non-employees, etc. User-friendly sizes, quality, and the most engaging content of each platform are considered when creating content. The platforms are selected by considering the type of content. Ex-: YouTube for videos. Photos, videos, Digital Broachers, instant articles, blog posts related to the tourism were published in that platforms to promote tourism.

Analyzing stage of the project was started after launching and maintaining the digital media platforms. Platforms were monitoring time to time for getting better output over the content types. The tools that are provided from each platform are used to analyze the project. Engagements, views, and other content counts can be analyzed by using those tools. Finally the results of the project were finalized from the data sourced from the each tool.

## 5.1 RESULTS AND DISCUSSION

### 5.1. Promoting Sri Lanka Tourism through Digital Marketing Effectively

In the project research period, more contents related to tourism, like destinations and industries were published in the created platforms such as Facebook, YouTube, Instagram and etc. As the results of the project the following table revealed the total audience of each platform in around a year.

Table 2: Total Audience

Digital Platform	Followers / Subscribers
Facebook (Ceylon Sri Lanka)	6,664
Facebook (Rakagamu)	1,372
Youtube	352
Twitter	18
Instagram	1,104
LinkedIn page	78
Pinterest	158

## 5.2. Most Effective Digital Platform Based on the Type of the Content

Table 3: Click through Rate

Platform	Reach	Engagement	C.T.R. (%)
Facebook	1,217,201	167,718	0.0014
Instagram	21,086	4,809	0.0023
Twitter	4,520	109	0.0002
Pinterest	1,080	25	0.0002
Youtube			6.1

Click – through rate (CTR) is the KPI for this analysis. The ratio of users who click on a single link to the overall number of users that view a page, email, or advertisement is known as the click-through rate. CTR is calculated by using engagements of the contents and reach of the contents published on platforms around a year.

$$CTR = (Engagement / Reach) \% \quad (Eq : 01)$$

From the above analyzing CTR for the Instagram is 0.0023%. So Instagram is the most effective platform because the highest C.T.R. goes to Instagram in all types of content.

If the content type is video, the best platform is YouTube because it has the highest C.T.R. of 6.1%.

## 6. CONCLUSIONS AND RECOMMENDATIONS

### 6.1. Conclusion

This study supports getting a great analysis regarding promoting Sri Lanka tourism through digital marketing effectively. The platforms that created in this project, Reached many audiences by this project. There are lot of digital media platforms to promote tourism. Contents were published daily in all the platforms around a year according to the collected data. The objective of this project was promoting Sri Lanka tourism effectively in Digital Media Platforms and Finding the most effective digital media platforms through that.

As the result of it lot of people gather around the all platforms. So as the results of the project, tourism was promoted effectively in Sri Lanka But according to the collected data Instagram is the most effective platform for promoting tourism among the all platforms because many people engage with this than others.

After the study, all the objectives were achieved and this project research can be a great effort for Sri Lanka tourism.

### 6.2. Recommendations

It is recommended that the Ministry of Tourism focuses on Digital marketing by giving opportunities to content creators. They are the people who promote tourism to the various types of audience segments. Further the Cleaner Production Policies should regulate strictly among the Firms, and the practices should also regulate foreign travelers and locals. Considering the content type when publishing and promoting through each digital media platforms to take the advantage over the audience preferences should also be regulated.

## REFERENCES

- Pitana, I.G. and Pitanatri, P.D.S., (2016). Digital marketing in tourism: the more global, the more personal. In International Tourism Conference: Promoting Cultural and Heritage Tourism. Udayana University, Bali (pp. 1-3).
- Adaderana Biz. (2020). COVID-19 impact: Sri Lanka tourist arrivals down 70.8% in March 2020. Adaderana Biz English Sri Lanka Business News. <http://bizenglish.adaderana.lk/covid-19-impact-sri-lanka-tourist-arrivals-down-70-8-in-march-2020/>
- Data Reportal. (2020). *Digital 2020: Sri Lanka*. <https://datareportal.com/reports/digital-2020-sri-lanka>.
- Kaur, G. (2017) "THE IMPORTANCE OF DIGITAL MARKETING IN THE TOURISM INDUSTRY", International Journal of Research -GRANTHAALAYAH, 5(6), pp. 72–77. doi: 10.29121/granthaalayah.v5.i6.2017.1998.
- IPL. (n.d.). *Literature Review on Ecotourism*. <https://www.ipl.org/essay/Literature-Review-On-Ecotourism-P3JEEGHEAJF6>
- Ramaj, B. and Ukaj, F. (2018). Review of literature for internet marketing and social media in tourism. Acta Universitatis Danubius. Communicatio, 12(2).
- SLTDA. (2019) Sri Lanka Tourism Development Authority. <https://www.slt-da.gov.lk/en>

# Impact of Technological Amenities on the Operational Performance of Hotels: A Case Study Based on Galle District

D.M.P. Madhushani<sup>\*1</sup>, C.P. Danthanarayana<sup>2</sup>, S.F Fazana<sup>3</sup>

<sup>1</sup>Department of Tourism Studies, Uva Wellassa University of Sri Lanka, Sri Lanka

<sup>2</sup>Division of Management Studies, University College of Matara, Sri Lanka

<sup>3</sup>Department of Management Sciences, Uva Wellassa University of Sri Lanka, Sri Lanka

## ABSTRACT

*Technology is embedded with the hospitality industry as a contributor to expanding the industry globally. Hotels are using different innovative technological amenities and there is a problem whether these amenities are actually influencing the hotel's operational performance. Mainly the study objective is to identify the impact of technological amenities on the hotels' operational performance. Data has been collected from department heads in sixty hotels that are registered under Sri Lanka Tourism Development Authority and located in Galle district. A cluster sampling technique has been used to select the sample and to collect primary data, it has used a structured questionnaire. SPSS statistical software has been used for the data analysis and Descriptive statistics, Karl Pearson's coefficient of correlation and multiple regression analysis have been used. Based on the results, the researcher has identified that all the identified technological amenities; Reservation Technology, In-Room Technology, Comfort Technology, Business Essential Technology, and Internal Assess Technology have strong positive correlations with the operational performance of hotels. It can be concluded that reservation technology has the most influencing relationship with hotels' operational performance. Moreover, Internal Assess Technology has no significant relationship, and all other amenities have a significant relationship with the operational performance of hotels. Technological amenities impact the operational performance of hotels by enhancing time-saving, maintaining cost efficiency, and enhancing service quality.*

**Keywords:** Hospitality Industry; Operational Performance; Technological Amenities

## 1. INTRODUCTION

According to the World Tourism Organization (WTO), the tourism and hospitality industry is an accelerated augmentation industry. Most of the industries obtain innovative technologies to become accelerate the augmentation industry. Today, most of the hotels often utilize innovative technologies to attain the below-mentioned outcomes: increase efficiency and quality of performance, reduce the cost & time wastage, value-adding for operational activities, problem-solving, unique way of producing and delivering the tourism products in the hotel industry, providing a competitive advantage, enhanced organization performance, improve guest satisfaction and build loyalty among clients and employees (Hjalager, 1997; Desouza et al., 2008; Schramm et al., 2008; Bilgihan et al., 2011). Sri Lankan business firms also acquire innovative technologies to enhance productivity and increase overall performance. In the present and past Sri Lankan governments also paid attention to the tourism industry to develop economic growth by implementing and formulating tourism strategic plans, (2011-2016, & 2017-2020). The Tourism & Hospitality industry acquires innovative technology to provide unique, quality, and quick service since it plays an important role within the industry. Cobanoglu et al. (2011) assessed the effect of innovative technology amenities on customer (guest) satisfaction. It has measured guest satisfaction using four types of innovation: in-room technology innovation, comfort technology innovation, business essential innovation, and internal assessment innovation. These technologies are influencing guest satisfaction, and however, those are not the only factors that affect the hotel's operation. Past literature has focused on the relationship of innovative technology with service quality, customer satisfaction, and consumer loyalty. However, these studies, it has not explored the

---

\* Corresponding Author: E-mail - [promodikamadhushani@gmail.com](mailto:promodikamadhushani@gmail.com)

relationship between innovative technologies and hotel operational performance, which is the gap concerning this study.

Previous researches over the past few years focus primarily on innovation with the different industries. Han, Kim, & Srivastava (1998) researched the banking industry and Maydeu-Olivares & Lado (2003) conducted their study in the insurance industry and conducted research in the hospitality industry (Sandvik & Sandvik, 2003). However, according to Enkel, Gassmann, & Chesbrough (2009), studies on service innovation are less compared with studies on product innovation. Researches on hotel performance is also less compared to guest satisfaction. Most of the scholars are concerned with or measure the relationship between guest satisfaction and innovative technologies and how innovative technologies impact guest satisfaction (Ranasinghe et al., 2020). In the present years, competition depends on innovative technologies in the hotel industry. In Sri Lanka, there was a lack of studies in this area. Therefore, there is an empirical gap in the effect of technological amenities on a hotel's operational performance. The current study will provide empirical knowledge on identifying the impact of technological amenities on the hotel's operational performance.

The study is focusing on the research objectives as;

To identify the current level of innovative technological amenities in SLTDA registered hotels in Galle district.

The relationship between innovative technological amenities and hotel operational performance in SLTDA registered hotels in Galle district.

## **2. LITERATURE REVIEW**

### **2.1. Sri Lankan Hospitality Industry**

The services industry has reached prompt development at the international level and it has greatly supported the overall economy in the world in terms of economies of scale. The tourism industry, as the third-highest foreign income earner in 2019, is playing a significant role in the Sri Lankan economy while providing 173,592 employment opportunities for Sri Lankan job market (SLTDA, 2019). Initially established tourism industry on the south coast has focused on mass international tourism based on the "Sea, Sun and Sand" concept (Danthanarayana and Arachchi, 2020). Galle is one of the major tourism hubs in the southern coastal belt and there are a large number of hotels and tourist attractions are located in Galle.

### **2.2. Innovative Technological Amenities**

Iwai (1984) has built a theory about innovation. He defined innovation as "new ways of doing things". The concept innovation covers novel and creative concepts on top of the practical applications of findings. Apart from that, service innovation is presenting novel ways into one's personal life, overall organization, placement, and timing of individual and collective service delivery process (Weiermair, 2004). However, it is originally resulting from the Latin verb "innovate", denoting for converting a thought or a process into a novel product or service that can be marketable which is adding value to it (Peters and Pikkemaat, 2015, Pirnar et al., 2012). Cobanoglu et al (2011) emphasize that it is a positive relationship between innovative technologies and customer satisfaction. The study identified comfortable technologies influence guests' satisfaction. Moreover, this study highlights comfortable technologies and business-related technologies that influence professional MICE travelers.

### **2.3. Organizational Performance**

There are large amount of technological amenities in the hotel industry, which are straightly influencing the performances of hotels. As per the past researchers, organizational performance links to the success of an organized set of individuals with a specific goal to achieve a task. Generally, based on the financial performance, new services and products are evaluating (Montoya-Weiss and Calantone, 1994). However, financial evaluation neglects different benefits to the organization as it limits to only one area. The results of past researches have revealed that effectiveness of one particular performance

evaluation element does not essentially relate to the effectiveness of the other performance element (Cooper and De Brentani, 1991). Brentani (1991) evaluates the operational performance through six measures: “market share, new services innovation, cost efficiencies, customer satisfaction, positive employee feedback, and service quality”. As per the Pirnar et al. (2012), operational performance is assessed by market share, new service introduction, quality of service, effectiveness of marketing, and customer satisfaction. (Ottenbacher et al., 2006) examined the dimensions affecting innovation performance in the hotels and it measured the performance by using total sales, market share, profitability, developed loyalty, enhanced organizational image, improved profitability, newly opened markets, newly attracted customers, cost efficiencies, positive employee feedback, and employee competencies.

#### **2.4. Technological Amenities in Hotels and Hotel Performance**

Cobanoglu et al (2011) emphasized the positive association between innovative technologies and the satisfaction of customers and it revealed guests’ overall satisfaction influenced by comfort technologies. Moreover this study highlighted comfortable technologies and business-related technologies are influencing professional MICE travelers and that study identified the main amenities which are satisfying customers such as; in-room voice mail/ messaging, in-room guest control panel, in-room fitness system, and in-room universal battery charger. Furthermore, technological amenities which cause the least customer satisfaction are automated check-in and check-out system, in-room telephone, in-room alarm clock, in-room PC, and easily accessible electronic outlets. Beldona and Cobanoglu (2007) highlighted innovative technologies have only a minimal effect on hotel’s operational performance and it has assessed the top five technological amenities as; “in-room temperature control system, online reservation capabilities, easily accessible electronic outlets, wireless internet access in the hotel and the business center amenities”. Sorescu et al. (2011) have highlighted that IT abilities and IT competencies can assist hotels to reach competitive advantage and it has classified IT-based technological amenities into four sections;” front-office applications, back-office applications, restaurant and banquet, and guest-related interface applications”. Current Information applications are benefited in the employee recruitment and selection, training and development, empowerment, low formalization, behavior-based performance evaluation, and a strategic direction to Human Resource Management. The current study identified the technological amenities and their impact on hotels’ operational performance.

### **3. METHODOLOGY**

#### **3.1. Research Population and Samples**

The research population is all (474) Sri Lankan hotels that are registered under Sri Lanka Tourism Development Authority (SLTDA). Sixty hotels have been selected from SLTDA registered (one-star to five-star) hotels and unclassified hotels in Galle district (03 one-star hotels, 06 two-star hotels, 06 three-star hotels, 09 four-star hotels, 05 five star hotels, and 31 unclassified hotels). By using the cluster sampling technique, the sample has been identified for this study.

#### **3.2. Data Collection Method**

Structured questionnaire to be filled by the managerial level employees (department heads in operational departments) to collect data. However, in ascertaining the questionnaire on internal consistency and validity of questions, a pilot research was performed, and beforehand questionnaire was tested for the content validity for the supervisor, and the hotels. Cronbach’s Alpha value has measured to identify the internal reliability of the indicators used in the questionnaire. According to the results of the reliability test, all dimensional variables are at the accepted level of 0.5.

#### **3.3. Data Analysis Technique**

SPSS software has been used for statistical treatment of data and to assess the proposed hypotheses in the conceptual model. Researcher has used descriptive statistics techniques to summarize the data. In addition to that Pearson’s correlation coefficient (“r”) was used to evaluate the association among study



variables. Besides, the relative contribution of the independent variable towards the dependent variable was analyzed by using the multiple regression analysis.

#### 4. DATA ANALYSIS AND DISCUSSION

According to the statistics, one-star hotels represent the smaller number of SLTDA hotels in the Galle district. In numbers, the percentage of one-star hotels are 5.2%, two-star hotels are 10.3%, three-star hotels are 8.6%, four-star hotels are 15.5%, five-star hotels are 6.9% and unclassified hotels are 53.4%. So, the response rate of the questionnaire is 96.7%.

##### 4.1. Descriptive Statistics

Table 1: Descriptive Statistics of Independent Variable

Technological Amenities	N	Mean		Skewness	
		Statistic	Std. Error	Statistic	Std. Error
Reservation Technological Amenities (RT)	58	4.1621	.07051	-.607	.314
In-Room Technological Amenities (IRT)	58	3.9397	.09189	-.265	.314
Comfort Technological Amenities (CT)	58	3.9207	.07476	-.164	.314
Business Essential Technological Amenities (BET)	58	4.0259	.07056	-.117	.314
Internal Assess Technological Amenities (IAT)	58	4.0259	.07891	-.220	.314

As per the above descriptive statistics, all the mean values of variables are close to Likert scale 5 except IRT and CT, however, those two technologies are belonging to the agreed level. Therefore, hotels' operational performance responses somewhat agree with the level of RT, BET, IAT, IRT, and CT.

##### 4.2. Karl Pearson Correlation Coefficient Analysis

The Karl Pearson correlation coefficient analysis technique is used to accept or reject the hypothesis. The correlation coefficient (-1 to 1) is determining the direction (positive/ negative) and strength (strong/ moderate/ weak) of the linear relationship among two variables.

Table 2: Correlation Statistics of Innovation technologies

Operational Performance (OP)	Pearson Correlation ( $\beta$ )	Sig. (2-tailed) (P)
RT	0.889	0.000
IRT	0.742	0.000
CT	0.617	0.000
BET	0.816	0.000
IAT	0.794	0.000

According to Table 2, the correlation between the RT and OP is 0.889 and it suggests the strong positive linear relationship among RT and the OP. Moreover, it illustrates the correlation between IRT and OP. It denotes a 0.742 amount of correlation between IRT and the OP, there is a strong positive linear relationship among variables. It explains a 0.617 amount of correlation between CT and the OP, which has suggested the moderate positive linear relationship among variables. Correlation between BET and OP denotes a 0.816 amount of correlation among BET and the OP, which has suggested the strong positive linear relationship among variables. It illustrates the correlation between IAT and OP and denotes a 0.794 amount of correlation among IAT and the OP has suggested that there is a strong positive linear relationship among variables. All these relationships are statistically significant at 0.000 p value.

##### 4.3. Multiple Regression Analysis

In regression, there are some assumptions to be proved before run a regression analysis. These all assumptions are tested and prove to improve the validity of the regression results. Multiple regression analyses has conducted to recognize the relationship between variables.

Table 3: Multiple Liner Regression Analysis

Model	Unstandardized Coefficients		Beta	T Value	P Value
	B	Std. Error			
	.487	.188		2.593	.012
<b>RT</b>	.682	.093	.718	7.332	.000
<b>IRT</b>	.299	.050	.410	5.976	.000
<b>CT</b>	-.250	.068	-.279	-3.697	.001
<b>BET</b>	.308	.110	.324	2.785	.007
<b>IAT</b>	-.151	.094	-.177	-1.598	.116

Based on the regression analysis results regression equation can be illustrated as follows,  
 $OP = 0.487 + (0.682 * RT + 0.299 * IRT - 0.250 * CT + 0.308 * BET - 0.151 * IAT)$  (Eq.01)

The coefficient of RT is 0.682. It explained that when RT has increased by one unit, OP increase by 0.682 times. Moreover, it implies a positive relationship between RT and the OP. The coefficient of IRT is 0.299. It explained that when IRT was increased by one unit, OP increased by 0.299 times. It implies a positive relationship between IRT and the OP. And the coefficient of CT is -0.250. It explained that when CT was increased by one unit, OP decreased by 0.250 times. It implies a negative relationship between CT and the OP. The coefficient of BET is 0.308. It explained that when BET has increased by one unit, OP increased by 0.308 times. It implies a positive relationship between BET and the OP. The coefficient of IAT is -0.151. It explained that when IAT has increased by one unit, OP decrease by -0.151 times. It implies a negative relationship between IAT and the OP. Its significant value is more than 0.05. That is rejecting in the multiple regression.

Table 4: Regression Analysis-Model Summary

Model	R	R Square	Adjusted R Square	Std. Error of the Estimate
<b>1</b>	0.944	0.891	0.883	0.17431

As per the above model summary, the multiple correlations (R) is 0.944. As the coefficient is larger than 0.7, there is a strong relationship among independent variables RT, IRT, CT, BET, and IAT and the dependent variable, OP. It indicates that there is a strong association among above mentioned technological amenities and hotel operational performance. The coefficient of determination (R<sup>2</sup>) assesses the correctness of fit of the regression line to the set of data. It explained that measure the proportion or % of total variation independent variable; it was explained by the independent variables. When considering the summary of the linear regression model the R<sup>2</sup> value was 0.894, the adjusted R<sup>2</sup> value was 0.883 and the standard error estimate was 0.17431. It suggested that how data differed from the fitted regression line. As per the regression result, the R Square value explains the 0.891 impacts of technological amenities on the hotel OP. The other 0.106 not explain in this research. As the regression ANOVA result is significant, the model has been said to be appropriated.

Table 5: Regression Analysis-ANOVA

Model	Sum of Squares	Df	Mean Square	F	Sig.
<b>Regression</b>	13.274	5	2.655	87.374	0.000
<b>Residual</b>	1.580	52	.030		

In the ANOVA table, F-ratio assesses model fit of the overall regression model. F, 87.374 explains that the overall statistical significance of the regression model. This indicates that the overall model can predict the dependent variable significantly. And it is supported by the p-value of the model which is 0.000 ( $P < 0.05$ ), and the regression model is statistically significant. Hence the regression model is appropriate. It indicates that all the five independent variables (technological amenities) have been jointly influenced by the hotel operational performance development. As per the above ANOVA table, it can conclude the model is statistically significant.

## 5. CONCLUSION

### 5.1. Conclusion

The first objective has been measured by descriptive statistics, and all the mean values of variables are close to the Likert scale 5. According to the standard deviation, the researcher verified the variance of variables. The maximum standard deviation that is 1.009 belongs to robots for cleaning services. Therefore, it has the highest variance. The minimum standard deviation of 0.627 belongs to wireless internet access. Therefore, it has the minimum variance. According to the coefficient of skewness, the values of technological amenities are between -1 & +1. Therefore, the data set is normally distributed. Basically RT, CT, IAT are using at a satisfactory level at the selected hotels in the Galle district. The second objective was analyzed through Karl Pearson's Correlation Coefficient using the data collected from a field survey. The correlation between RT and OP is 0.889 and it implies a strong positive linear relationship among RT and OP. There is 0.742 correlation among IRT and it implies a strong positive linear relationship among variables. The correlation among CT and the OP denotes a 0.617 amount and it is a moderate positive linear relationship among said variables. Correlation between BET and OP denotes a 0.816 amount and it is suggested that there is a strong positive linear relationship among these two variables. The correlation between IAT and OP is 0.794 and it is suggested that there is a strong positive linear relationship among these two variables. 0.873 amount of correlation between TA and the OP suggested the strong positive linear relationship among variables. Multiple regression analysis has been used to analyze the effect of TA on OP. The coefficient of RT is 0.682. It explained that when RT is increasing by one unit, OP has increased by 0.682 times. The coefficient of IRT is 0.299. It explained that when IRT has increased by one unit, OP increase by 0.299 times. It implies a positive relationship between RT, & IRT, and the OP. And the coefficient of CT is 0.250. It explained that when CT was increased by one unit, OP decreased by 0.250 times. It implies a negative relationship between CT and the OP. The coefficient of BET is 0.308. It explained that when BET was increased by one unit, OP increased by 0.308 times. It implies a positive relationship between BET and the OP. The coefficient of IAT is -0.151. Its significant value is more than 0.05. That has been rejected in the multiple regression equation.

### 5.2. Suggestions and Recommendation

Technology is playing a big part in the hotel industry. To achieve the ultimate goal of earning more profit, people have to update with modern technological amenities to get optimum benefits. Therefore, the knowledge and the awareness of the current trends in technology in the hotel industry should be increased. Then identification of the hidden trends and techniques to earn profits through the innovation technology and to maintain international standards are important. Moreover, the marketing and promotions by using modern technologies such as social media networks is important to keep customers more aware about hotel facilities, services and offers. In the present world, technology becomes a part of how we travel. Tourists changed their travel plans due to the impact of social media. And also travelers refer travel reviews on travel sites prior making a booking and half say that review is the highest inspiration on their booking choice. So social media is the best and low-cost way to do effective marketing and promotions.

And reservation technologies are the most important technology to increase the efficiency of the front office department. It helps to reduce & identify duplicate booking and overbooking. And also guest payment system also needs to be flexible & effective in check-in & check-out operation. Because any payment mode accepts to pay and there is a facility to pay, it helps to run smooth check-out operation & to provide professional customized service to the guest. Especially this technology impact increases the hotel's service quality & time-saving. In-room wireless key card systems & electronic safety boxes are the latest innovative technologies. The wireless key cards can be easily installed in the new or existing building and it helps users avoid significant disruptions. So these technologies highly contribute to guest safety and cost-effectiveness. And comfort technologies are cost center technologies, but the newest technologies help to reduce cost and increase service quality. Soil water separate system is the

best example. Because Soil water separate system technology practicing 3R concept. The study findings show that the current amount of technological amenities in the hotel industry. Therefore, there should be a necessary technic to maintain and improve the Hotel Operation Performance. Service Quality, Time Saving, Cost Efficiency, and New Service Introduction has a high contribution to Hotel Operational Performance. So that it can suggest service quality should be maintained at the international level with the Innovation Technological Amenities. And also those technologies are helping to save time-consuming and increase the cost efficiency caring the hoteliers' for the ultimate goal of utilizing resources and optimization the profit earning. So according to past research and the research result can suggest innovative technological amenities for hoteliers to improve hotel performance.

### 5.3. Limitations

As the major limitation, it can be stated that there are some respondents in hotels, who are not willing to give the required information. Therefore, the researcher has to face some difficulties in data collection. Furthermore, this research concerned the whole population of SLTDA registered hotels in the Galle District. Therefore, future researchers can conduct the same research in the Sri Lankan context. Moreover, future researchers can compare the determinants of Operational Performance between emerging tourism destinations like Sri Lanka, Maldives, Seychelles and France. Furthermore, as a future research area, Researchers should conduct studies to identify the other determinants of Operational Performance. And this research mostly concerns only the front office department and back-office department Innovation Technological Amenities, furthermore as the future researcher can study in the food and beverage Departments' Innovation Technological amenities and its impact on the Hotel Operation Performance. As well, future researchers can conduct research on how Innovation Technology determinants impact Financial Performance and employee performance.

### REFERENCES

- Atalay, M., Anafarta, N. and Sarvan, F., 2013. The relationship between innovation and firm performance: An empirical evidence from Turkish automotive supplier industry. *Procedia-social and behavioral sciences*, 75, pp.226-235.
- Beldona, S. and Cobanoglu, C., 2007. Importance-performance analysis of guest technologies in the lodging industry. *Cornell Hotel and Restaurant Administration Quarterly*, 48(3), pp.299-312.
- Bilgihan, A., Okumus, F. and Kwun, D.J.W., 2011. Information technology applications and competitive advantage in hotel companies. *Journal of Hospitality and Tourism Technology*.
- Bryce Cooper, A., 1994. Coupling wetland treatment to land treatment: An innovative method for nitrogen stripping?. *Water science and technology*, 29(4), pp.141-149.
- Burgelman, R.A., Maidique, M.A. and Wheelwright, S.C., 1996. *Strategic management of technology and innovation* (Vol. 2). Chicago: Irwin.
- Cobanoglu, C., Berezina, K., Kasavana, M.L. and Erdem, M., 2011. The impact of technology amenities on hotel guest overall satisfaction. *Journal of Quality Assurance in Hospitality & Tourism*, 12(4), pp.272-288.
- Cooper, R.G. and De Brentani, U., 1991. New industrial financial services: what distinguishes the winners. *Journal of Product Innovation Management*, 8(2), pp.75-90.
- Danthanarayana, C.P. and Arachchi, R.S.S.W., 2020. Role of Restaurant Attributes and Customer Perceived Value in Shaping Customer Satisfaction: A SEM Based Analysis in Beach Restaurants in South Coast, Sri Lanka. *Journal of Management and Tourism Research (JMTR)*, p.45.
- De Brentani, U. and Cooper, R.G., 1992. Developing successful new financial services for businesses. *Industrial Marketing Management*, 21(3), pp.231-241.
- Desouza, K.C., Awazu, Y., Jha, S., Dombrowski, C., Papagari, S., Baloh, P. and Kim, J.Y., 2008. Customer-driven innovation. *Research-Technology Management*, 51(3), pp.35-44.
- Enkel, E., Gassmann, O. and Chesbrough, H., 2009. Open R&D and open innovation: exploring the phenomenon. *R&d Management*, 39(4), pp.311-316.
- Fernando, S., Bandara, J.S. and Smith, C., 2016. Tourism in Sri Lanka. *The Routledge Handbook of Tourism in Asia*, pp.251-264.

- Han, J.K., Kim, N. and Srivastava, R.K., 1998. Market orientation and organizational performance: is innovation a missing link?. *Journal of marketing*, 62(4), pp.30-45.
- Hjalager, A.M., 1997. Innovation patterns in sustainable tourism: An analytical typology. *Tourism management*, 18(1), pp.35-41.
- Iwai, K., 1984. Schumpeterian dynamics: An evolutionary model of innovation and imitation. *Journal of Economic Behavior & Organization*, 5(2), pp.159-190.
- Maydeu-Olivares, A. and Lado, N., 2003. Market orientation and business economic performance: A mediated model. *international journal of service industry management*.
- Montoya-Weiss, M.M. and Calantone, R., 1994. Determinants of new product performance: A review and meta-analysis. *Journal of product innovation management*, 11(5), pp.397-417.
- Peters, M. and Pikkemaat, B., 2015. InnoTour: An innovation in tourism policy. In *Tourism and Leisure* (pp. 51-64). Springer Gabler, Wiesbaden.
- Pirnar, I., Bulut, C. and Eris, E.D., 2012, September. Improving the performance and competitiveness of tourism establishments by means of innovation: trends and applications. In *Proceedings of IRAT „Enlightening Tourism “Conference, Naples, Italy* (Vol. 211).
- Ranasinghe, J.P.R.C., Danthanarayana, C.P., Ranaweera, R.A.A.K. and Idroos, A.A., 2020, May. Role of destination smartness in shaping tourist satisfaction: A SEM based on technological attributes in sri lanka. In *IOP Conference Series: Earth and Environmental Science* (Vol. 511, No. 1, p. 012001). IOP Publishing.
- Sandvik, I.L. and Sandvik, K., 2003. The impact of market orientation on product innovativeness and business performance. *International journal of Research in Marketing*, 20(4), pp.355-376.
- Schramm, C.J., Arora, A., Chandy, R.K., Cooper, K., Jorgenson, D.W., Siegel, D.S., Bernd, D.L., Ballmer, S., Blanchard, J., Buckley, G. and Collins, A., 2008. Innovation measurement: Tracking the state of innovation in the American economy. Available at SSRN 1090630.
- Sorescu, A., Frambach, R.T., Singh, J., Rangaswamy, A. and Bridges, C., 2011. Innovations in retail business models. *Journal of retailing*, 87, pp.S3-S16.
- SLTDA. (2020). *Annual Statistical Report 2019*. Colombo. [Online] <https://www.slttda.gov.lk/en/annual-statistical-report> [Accessed 28 August 2021]
- Weiermair, K., 2004. Product improvement or innovation: what is the key to success in tourism, paper presented at the 77<sup>th</sup> session of the OECD tourism committee, Rome, 22 June, 2004

# Motive for Community Involvement in Tourism Entrepreneurship: with Special Reference to Southern Province in Sri Lanka

K.P.I.S. Jayasekara<sup>\*1</sup>, G.T.W. Sriyani<sup>2</sup>

<sup>1</sup>Division of Management Studies, University College of Matara, Sri Lanka

<sup>2</sup>Department of Management and Entrepreneurship, University of Ruhuna, Sri Lanka

## ABSTRACT

*Tourism is one of the largest industries which develops the economy of any country specifically contributing to more foreign exchange earnings and boosting a large number of direct and indirect employment opportunities. Many developing and least developed countries have identified community involvement in tourism activities as a tool for achieving the country's socio-economic goals specifically eradicating poverty among rural poor, diversifying the local economy, and enhancing tourism sustainability. Prior studies identified that stimulation for community involvement in tourism happens due to opportunity-driven motives or necessity-driven motives. The focus of this research is to reveal the effect of these two types of entrepreneurial motives on community involvement in tourism entrepreneurship and determine which type of motive have a strong affect. Under the positivism phenomena, the quantitative approach was applied for this study. Population is the community tourism entrepreneurs in rural tourism destinations in Sri Lanka and Mirissa, Unawatuna, Viharahena and Mederipitiya selected as research sites. One hundred and thirteen tourism entrepreneurs were used as the sample and the systematic random sampling technique was applied to select the sample. A structured questionnaire was used for data collection and a regression analysis technique was used for testing the hypothesis of the study. Findings revealed that opportunity-driven motives affect highly and significantly the involvement in community tourism activities and among the opportunity-driven motives, "independence and Freedom" was the most popular motive of the study sample. Findings imply that the tourism entrepreneurs who started the business with opportunity-driven motives involved more in community tourism business activities while such an impact cannot be identified with the tourism entrepreneurs who started community tourism with necessity-driven motives.*

**Keywords:** Community Involvement, Necessity Driven Motive, Opportunity Driven Motive, Tourism Entrepreneurship.

## 1. INTRODUCTION

World Tourism Organization (WTO) has recognized the tourism industry as one of the growing industries in the world which contributes to the economic development in many countries. The impact of socio-economic development has been identified in terms of contribution to Gross Domestic Production (GDP), employment creation, foreign exchange earnings, diversifying local economic activities, poverty reduction, improving quality of life of the people, etc. In the world context, community involvement in tourism businesses is gradually increasing with the demand shifts happened from "Mass Tourism" which focuses on 3Ss concepts (Sun, Sea and Sand) towards "Niche Tourism" which focuses on nature, culture and people (Sriyani, 2021, P.226). Therefore, tourists expect an exciting experience from the community tourism which focuses on differentiated tourism activities which are unique to the local people, culture and nature. Community involvement in tourism activities have been identified by many developing and least developed countries as a tool for poverty reduction, diversifying local economy, improving quality of life of the poor people, and ensure the sustainability in the tourism industry. Also, community tourism is one of the contemporary types of tourism in today's context due to diversifying the demands on tourism products and services. Therefore, not only the

---

\* Corresponding Author: E-mail - [88shashin@gmail.com](mailto:88shashin@gmail.com)

tourism entrepreneurs and guests but also the researchers in tourism field have made the attention on community involvement in tourism.

Any type of business startups will happen due to either opportunity-driven or necessity-driven motives. According to Ivanova et al. (2017), necessity is focused on needs and opportunity entrepreneurship is based on voluntary engagement or market opportunity (cited in Suchart, 2017). Michael (2009) stated that, in rural Tanzania community recognizes that community participation in tourism will contribute to poverty reduction with the new jobs it creates and if tourism can provide incomes. Past researchers had highlighted the significance of the community involvement in tourism and poverty alleviation (Michael, 2009; Medina-Munoz, Medina Munoz & Gutierrez-Perez 2016) as well necessity and opportunity driven motives (Suchart, 2017; Williams, 2009; Sahasranamam & Sud, 2016) in their studies. Fairlie & Fossen (2017) emphasized that opportunity driven motives associated with initiation of growth-oriented businesses. Since previous studies have focused on the local communities at Tanzania, Kenya etc. there is a necessity to conduct similar studies in other developing countries. Hence, the objective of this study is to reveal, among the two types of business startup motives, either opportunity driven or necessary driven motives affect more on the community involvement in tourism businesses.

By studying the stimulating motives on involvement in community tourism, a specific tourism development policy and facilitating mechanism can be proposed to enhance the community participation in the tourism businesses. On the other hand, identification of which types of startup motive effect highly on the involvement of the community in tourism businesses may be helpful for the policy makers as well as the community to determine right type of empowerment. Also, the encouragement of the entrepreneurs who exhibit high growth potentials may ensure the local economic development as well as the sustainability in tourism industry. Moreover this study reveals the understanding of the theory of Stephan et al.'s theory of entrepreneurial motivations on business startup and involvement in tourism as well it leads to understand the rationality and strength behind entrepreneurial motives. Also contributes to the application and improvement of the foresaid theory in to different context and supports to apply the developed model in a broader context. Hence the findings can be used for future studies related to tourism entrepreneur motives and community involvement where it will be useful to develop systematic structure on community involvement in entrepreneurship.

## **2. LITERATURE REVIEW**

### **2.1. Entrepreneurial Motivations for Business Start-Up**

As cited in Roden and Stahle (2017) many authors have defined the concept broadly mentioning the formation of organizations (Gartner, 1988), creating new combinations (Schumpeter, 1934), explore opportunities (Kirzner, 1973), facing the uncertainty (Knight, 1921), the collection of production factors (Say, 1803). Motivation to entrepreneurship can be opportunity driven or necessity driven (Stephan et al., 2015). Opportunity based or pull factors referred to as positive motivations and necessity based or push factors referred to as negative motivations on entrepreneurship. One of the most important drivers for self-employment is that people want to run a business themselves instead of working for someone else (Gelderen and Jansen, 2006). Further he has mentioned that large majority of small business starters like to be responsible to decide on strategy to decide on working methods and to regular their own time. Freedom is also needed as a necessary condition for fulfillment of other motives. Blais & Toulouse (1990) proved 'need for independence' as the factor for startup (cited in Gelderen and Jansen, 2006).

### **2.2 Opportunity Driven and Necessity Driven Motives on Community Involvement in Tourism Business**

Fairlie and Fossen (2017) highlighted two motives for entrepreneurs to create businesses. As some entrepreneurs start their businesses when they identify a business opportunity even though they are employed and others are forced with a necessity because of lacking in other opportunities in labor

market or unemployment. Reynolds & et al (2002) classified entrepreneurs in to opportunity and necessity driven and entrepreneurs (cited in Zali, Faghih, Ghotbi & Rajaie, 2013). Vossenber (2013) stated that according to Global Entrepreneurship. Monitor (GEM), 2010 vast majority of women engaged in businesses driven by necessity rather than opportunity as no other options for income generation. Odege suggests that tourism is often reported to be more labor intensive than other productive sectors and there is a greater entrance of women and the youth in community level (2014). It was stated (Castelles & Portes, 1989; Portes & Walton, 1981; Sassen, 1997) as cited in Sahasranamam & Sud (2016) that entrepreneurs operating in informal sector are driven by necessity but Gerxhani (2004) (as cited in Sahasranamam & Sud, 2016) argued that entrepreneurs find more autonomy, flexibility and freedom leads to engage in informal businesses. Rasel (2004) as cited in Suchart (2017) classified market opportunity, high profit, social recognition, personnel development, autonomy as opportunity driven motives and unemployment, lower education, family pressure and lower income as necessity driven motives. Salleh et al. (2016) suggested local communities in tourism related business are influenced mainly by income and family encouragement. Odege (2014) highlighted that expansion of cultural tourism activities in a community creates opportunities for individuals to invest in related enterprises for income generation. Robichaud & et al., (2010) found that necessity entrepreneurs apparently less likely to dedicate to their business than opportunity entrepreneurs as they have a confident approach in businesses and propensity to perceive future business opportunities with an expectation of having more employees within five years which explain their level of involvement. Level of education and awareness on tourism is a critical component for the community to be able to access such benefits as scholarships, training and job opportunities growing from the tourism sector. Tourism education benefits to their home countries where they utilize their education and talent to increase in productivity and economic development by involve in tourism businesses. Local - authority has a responsibility for promoting and developing tourism business and planning, through awareness and disseminates the information through state, national and international media.

### 3. METHODOLOGY

The population of the study is entrepreneurs who engaged in community level tourism in Southern province of Sri Lanka. From village level tourism destinations in southern province of Sri Lanka, Mirissa, Unawatuna, Viharahena and Mederipitiya were selected as research sites. Southern province was selected for this study because large number of tourist arrivals was reported during the past few years (Annual Statistical Report of SLTDA, 2017). Based on the positivism paradigm, the quantitative approach was selected for this study. A structured questionnaire that was administered by the research team together with few open- ended questions was used to collect data. Multiple regression analysis was used to analyze the data and test the research hypothesis. Past researcher (Robichaud et al., 2010) argued that opportunity leads to more confident and professional approach in the tourism businesses rather than necessity. Solymossy (1997) as cited in Robichaud et al. (2010) suggest that positive motives make the entrepreneurs engaged in networking with other stakeholders than negative motives where community does not foresee business opportunities. Lordkipanidze et al., (2005) suggested that availability of more business supported public and private policies and availability of education and training are important as motives for involving in tourism businesses. Sahasranamam & Sud (2016) found that communities who are currently employed consider necessity entrepreneurship as a motive to involve in tourism business. In developing countries, majority of women are involved in tourism driven by necessity than opportunity as no employment or other source of income generation (Vossenber, 2013). Giacomini, Janssen, Guyot and Lohet, 2011 shows that young generation can be driven by both necessity and opportunity thus older entrepreneurs are driven solely by necessity entrepreneurship. Colin (2009) argued that more commonly women informal entrepreneurs are driven by necessity factors. It was found that married women are driven by motives as family commitment or joined family business and single women motivated by the desire for independence (Dawson and Henley 2012). Moreover, they have mentioned that younger women are driven by both push and pull motives where younger men consider independence and financial motives. The findings and arguments in the community tourism literature proved that contradictory views on which type of motive will enhance the community involvement in tourism businesses. Based on such arguments it was hypothesized that *“If the startup motive of the entrepreneur is opportunity driven, the degree of involvement in community*



*tourism businesses is high comparatively with the entrepreneurs who start the business with necessity driven motives.*

#### 4. DATA ANALYSIS AND RESULTS DISCUSSION

In identifying the startup motive as necessity driven motives and opportunity driven motives, eleven statements were presented in the research questionnaire. Accordingly, eleven statements were constructed and among those, five statements were focused on identifying whether the community people are necessity-driven entrepreneurs and other six statements were presented to identify the respondents as opportunity-driven entrepreneurs. The study assumes and intends to prove that opportunity driven motives highly influence on community to start up tourism related businesses than necessity driven motives. Results of descriptive statistics in this perspective are shown in Table 1. Among the opportunity driven motives, highest mean value (3.88) represents by the determinant of ‘Independence and Freedom’ and secondly ‘Desire for having my own business’ (3.70). Under necessity driven motives, ‘Improve the quality of life’ reported the highest mean value (3.33).

Table 1: Descriptive Statistics of Entrepreneur Motives

Variable	Item	Mean	St/ D
Necessity Driven	Improve the quality of life	3.33	1.039
	Desire for social recognition	3.16	0.969
	Dissatisfaction with former job	3.09	1.199
	Unemployment Status	3.02	1.261
	Encouraged by family members	2.82	1.046
Opportunity Driven	Independence and freedom	3.88	0.836
	Desire for having my own business	3.70	1.008
	High demand and growth potentials	3.24	1.197
	Diversified business opportunities	3.19	1.257
	Favorable/supportive business environment	3.05	1.308
	Attitude for serving to the community	2.70	1.202

##### 4.1 Relationship between Necessity and Opportunity Driven Motives on Community Involvement in Tourism Businesses

Main objective of this study was to reveal the most significant motive which effect on community involvement in tourism business. The hypothesis formulated for this study was “*If the startup motive of the entrepreneur is opportunity driven, the degree of involvement in community tourism businesses is high comparatively with the entrepreneurs who start the business with necessity driven motives*”. Multiple regression analysis was used to test this hypothesis and Table 2 depicted the results of multiple regression analysis. Accordingly, R value of 0.384 shows that there is a positive correlation between the opportunity-driven motives and the community involvement in tourism businesses. However, the relationship is not strong.  $R^2$  is proportion of variance in the dependent variable that is explained by the independent variables. In this study, value of  $R^2$  is very low (0.147) and however significant. This value implies that 14.7 % (approximately 15%) of variation in community involvement in tourism businesses is explained by the opportunity driven motives. It says that where the startup motive is opportunity driven, it has a 14.7 % predictive power of community involvement in tourism businesses. Adjusted R Square of 0.139 describes how well this variable could be generalized and ideally its value close to  $R^2$ . Accordingly, it says that the relationship between opportunity driven motives and community involvement in tourism businesses if generalized to the population it would be approximately  $(0.147 - 0.139 = 0.008$  or 0.8%) 0.8% less variance in outcome. F value is 19.148 which is significant at 0.01 level. The t value is greater than 2 (6.191) and significant which implies that opportunity driven motive has a significant contribution to community involvement. These results

indicate that there is a positive relationship between opportunity driven motives and community involvement in tourism and the variance in community involvement is explained by the independent variable of opportunity driven motives.

Table 2: MRA Results for Testing Relationship between Opportunity Driven Motives and Community Involvement in Tourism Businesses

Model	R	R Square	Adjusted R Square	Std. Error of the Estimate	F	Sig.
1	.384 <sup>a</sup>	.147	0.139	0.83856	19.148	.000 <sup>a</sup>
<b>a. Predictors: (Constant), Opportunity</b>						
<b>b. Dependent Variable: Community Involvement</b>						
<b>Coefficient Statistics</b>						
Model		Unstandardized Coefficients		Standardized Coefficients	t	Sig.
		B	Std. Error	Beta		
1	(Constant)	1.653	0.267		6.191	.000
	Opportunity	0.373	0.085	0.384	4.376	.000

Table 3 shows the multiple regression results relating to the relationship between necessity driven motives and community involvement in tourism businesses. Accordingly, R value is 0.032 and R<sup>2</sup> value is 0.001 which is the proportion of variance in the dependent variable that is explained by the independent variable. The statistics show that very weak level of positive correlation between the necessity-driven motives and community involvement in tourism businesses. R<sup>2</sup> value of 0.001 indicates that 0.1 % of the variation in community involvement is explained by the necessity driven factors where least R<sup>2</sup> value represent unimportance of the data. This implies that comparatively with the opportunity driven motives, necessity driven motives have less predictive power of community involvement in tourism. However, the impact is insignificant because the P value (0.733) reported a higher value than 0.05 level of significance. As seen in Table 3, P-value is 0.733 and it implies that there is no significant impact from necessity-driven motives on the degree of involvement in community tourism businesses. The Beta value (-0.032) of the relationship shows a negative association which highlights that every one unit increment in necessity driven factors decreases the community involvement by 0.032. F value (0.117) is also insignificant. The t value is greater than 2 (6.521) and significant.

As discussed in the above sections, the argument behind the hypothesis was that the entrepreneurs who started a tourism business with opportunity driven motives involve more in community tourism business activities than the entrepreneurs who started their tourism businesses with necessity driven motives. The findings were supported for this argument and revealed that the involvement in tourism businesses is comparatively high when the entrepreneurs were motivated by the opportunity factors rather than necessity factors. This implies that the entrepreneur in a tourism destination, who starts a tourism business with opportunity driven motives has the possibility to engage in multi-tourism activities or greater involvement in the activities of community tourism association in the village which leads towards higher involvement in tourism. Hence the research hypothesis of this study (If the startup motive of the entrepreneur is opportunity driven, community involvement in tourism businesses will be high comparatively with the entrepreneurs who start the business with necessity driven motives) can be accepted.

Table 3: MRA Results for Testing Relationship between Necessity Driven Motives and Community Involvement in Tourism Businesses

Model	R	R Square	Adjusted R Square	Std. Error of the Estimate	F	Sig.
1	.032 <sup>a</sup>	0.001	-0.008	0.90753	0.117	0.733 <sup>a</sup>
<b>a. Predictors: (Constant), Necessity</b>						

<b>b. Dependent Variable: Community Involvement</b>						
<b>Model</b>	<b>Model</b>	<b>Coefficient Statistics</b>				
		<b>Unstandardized Coefficients</b>		<b>Standardized Coefficients</b>	<b>t</b>	<b>Sig.</b>
		<b>B</b>	<b>Std. Error</b>	<b>Beta</b>		
<b>1</b>	(Constant)	2.920	0.448		6.521	0.000
	Necessity	-0.046	0.134	-0.032	-0.342	0.733

Even though similar findings relating to tourism entrepreneurs were not available, several researchers have expressed similar views relating to other industrial settings. Dawson and Henley (2012) found that majority of the individuals have stated a reason for self-employment and it was “Independence” and it was the most commonly mentioned motivation and popular reason when considering both men and women. “Independence” as a factor mentioned under opportunity driven motives in this study resulted as the highest mean value of the independent variables which can be suggested as the reason to increase the influence of opportunity driven motives on business startup. But according to Salle et al. (2016) encouragement from family members to a tourism related business and continuing family business or the desire to pass the business to children are also influential factors. They also found that interest/passion for own a business, self-confident is an important stimulus for involvement in tourism. Also Benzing, Chu and Kara (2009) proved that personnel freedom and independence as the third reason to start and own a business. Williams (2009) revealed that informal entrepreneurs motivated mostly on opportunity driven motives while necessity driven motives also influence to some extent. Moses and Amalu (2015) suggested that lack of skills, infrastructure and capital influence on business start-up and involvement but has considered only women entrepreneurs on the study. Zali et al., (2013) proved that opportunity driven entrepreneurs have a positive effect on business growth and expectation. Salleh et al., (2016) proved that local communities prefer engage in businesses than occupations as they feel of having more free time than a job. Noorhayati et al. (2016) indicates that most of local communities motivated to involve in tourism by “pull factors” (opportunity driven) and most significant reasons were job opportunities they offer and personnel satisfaction as they manage their time and enjoying the working. Benzing, Chu and Kara (2009) stated that job security, to increase income and independence and freedom are factors that increase community involvement in tourism while Giacomini, Janssen, Guyot and Lohet (2011) suggested autonomy and independence is most frequent motivation in business initiation. Therefore, it is obvious that this study also proves the argument which was proved by the majority of the previous studies.

## 5. CONCLUSION AND RECOMMENDATION

The objective of this study was focused on “revealing the most significant motive on community participation in tourism related businesses”. The sample was from four research sites from Southern province, Sri Lanka and accordingly resulted that “Independence and freedom” and “Desire for having my own business” under opportunity driven motive respectively have the highest and second highest rated business startup motives of tourism entrepreneurs in the study sample. However, findings also reported that “Improve the quality of life” as the third highest impact which was categorized under necessity driven motives. Also findings revealed that entrepreneurs who had started their tourism business due to opportunity driven motives, involve comparatively higher in tourism businesses activities than those who had started the businesses with the motive of necessity driven. The least impact under opportunity driven determinants is the “Attitude for serving community” which depicts that such attitude does not significantly affect on business initiation or involvement decision though many initiatives were provided to the community to encourage for serve to the community and develop the local economy. Therefore it can be determined that through the determinants mentioned under opportunity driven motives, predominantly, improving the supportiveness of business environment, increasing the demand and diversifying business opportunities which are some of the probable arrangements that have a considerable impact, can be implemented to pull the community towards tourism businesses.

Findings revealed that seeking opportunities in the environment, freedom and independence in decision making and do in their own way, proud of having their own businesses are stimulated the entrepreneurs for more involvement in tourism businesses and engaging in diversified tourism business activities. These are good signs of the growth and sustainability in a particular industry. Therefore, a mechanism requires to be developed to reveal the opportunity driven tourism entrepreneurs and encourage and empower them to become the owners of the high-growth and diversified tourism businesses. Because of less involvement in tourism business activities by the necessity-driven tourism entrepreneurs, let them to involve in a single tourism business activity and facilitate them to become a competitive host firm in a particular community destination.

## REFERENCES

- Sri Lankan Tourism Development Authority. (2017) Annual Statistical Report. Available at: <https://sltda.gov.lk/storage/documents/0f7443899b258fa5bffb2ecc54e27.pdf>
- Benzing, C., Chu, H.M. and Kara, O., (2009). Entrepreneurs in Turkey: A factor analysis of motivations, success factors, and problems. *Journal of small business management*, 47(1), pp.58-91.
- Dawson, C. and Henley, A., (2012). “Push” versus “pull” entrepreneurship: an ambiguous distinction?. *International Journal of Entrepreneurial Behavior & Research*.
- Fairlie, R.W. and Fossen, F.M., (2018). Opportunity versus necessity entrepreneurship: Two components of business creation.
- Giacomin, O., Janssen, F., Guyot, J.L. and Lohest, O., (2011). Opportunity and/or necessity entrepreneurship? The impact of the socio-economic characteristics of entrepreneurs.
- Lordkipanidze, M., Brezet, H. and Backman, M., (2005). The entrepreneurship factor in sustainable tourism development. *Journal of cleaner production*, 13(8), pp.787-798.
- Medina-Munoz, D.R., Medina-Munoz, R.D. and Gutiérrez-Pérez, F.J., 2016. The impacts of tourism on poverty alleviation: An integrated research framework. *Journal of Sustainable Tourism*, 24(2), pp.270-298.
- Michael, M., (2009). Community involvement and participation in tourism development in Tanzania: a case study of local communities in Barabarani village, MTO WA MBU, Arusha-Tanzania.
- Moses, C. and Amalu, R., (2010). Entrepreneurial motivations as determinants of women entrepreneurship challenges. *Petroleum-Gas University of Ploiesti Bulletin*, (2), pp.67-77.
- Noorhayati, M.R., Hasmadi, I.M., Pakhriazad, H.Z. and Wahidin, A.K., (2016). Identifying motivation factors of the participation of local community in tourism industry in National Park, Pahang, Malaysia. *TOURISM & HOSPITALITY*, p.107.
- Odege, D.W., (2014). *Factors influencing community participation in cultural tourism at Kit Mikayi in Kisumu County, Kenya* (Doctoral dissertation, University of Nairobi).
- Robichaud, Y., LeBrasseur, R. and Nagarajan, K.V., (2010). Necessity and Opportunity-Driven Entrepreneurs in Canada: An Investigation into their Characteristics and an Appraisal of the Role of Gender. *Journal of Applied Business & Economics*, 11(1).
- Rödén, M. and Ståhle, H., (2017). The Motives for Entrepreneurship in Developing Countries; the Case of Nairobi.
- Sahasranamam, S. and Sud, M., (2016). Opportunity and necessity entrepreneurship: A comparative study of India and China. *Academy of Entrepreneurship Journal*, 22(1), p.21.
- Salleh, N.H.M., Shukor, M.S., Othman, R., Samsudin, M. and Idris, S.H.M., (2016). Factors of local community participation in tourism-related business: Case of Langkawi Island. *International Journal of Social Science and Humanity*, 6(8), pp.565-571.
- Sriyani, G. T. W. (2021). Impact of Social Capital Empowerments on the Businesses Success among the Micro and Small-Scale Tourism Entrepreneurs in Sri Lanka. *WAYAMBA JOURNAL OF MANAGEMENT VOLUME 12 ISSUE 01 JUNE 2021*, 225.
- Stephan, U., Hart, M., Mickiewicz, T. and Drews, C.C., (2015). Understanding motivations for entrepreneurship.
- Suchart, T., (2017). Factors influencing opportunity driven nascent entrepreneurs in Europe and Asia.
- Van Gelderen, M. and Jansen, P., 2006. Autonomy as a start-up motive. *Journal of small business and enterprise development*.

- Vossenbergh, S., (2013). Women Entrepreneurship Promotion in Developing Countries: What explains the gender gap in entrepreneurship and how to close it? *Maastricht School of Management Working Paper Series*, 8(1), pp.1-27.
- Williams, C.C., (2009). Informal entrepreneurs and their motives: a gender perspective. *International Journal of Gender and Entrepreneurship*.
- Zali, M.R., Faghih, N., Ghotbi, S. and Rajaie, S., (2013). The effect of necessity and opportunity driven entrepreneurship on business growth. *International Research Journal of Applied and Basic Sciences*, 7(2), pp.100-108.

# Role of Perceived Organizational Support in Determining Turnover Intention: A SEM on Employee Awareness of Smart Hotels in Sri Lanka

C.P. Danthanarayana<sup>\*1</sup>, M.A.D.J. Jayathilake<sup>1</sup>, R.M.P.D.K. Rajapaksha<sup>2</sup>

<sup>1</sup>Division of Management Studies, University College of Matara, Sri Lanka

<sup>2</sup>Division of Hospitality Management, University College of Batangala, Sri Lanka

## ABSTRACT

*Technological advancements of the new millennium have impacted almost every industry despite manufacturing or services. Thereby, hotels are focusing on converting their activities much smarter to offer a value-added service. This smart hotel concept is not yet popular in the hotel industry in Sri Lanka. Therefore the paper discusses the awareness of hotel employees on smart hotels, the technology and the hybrid operations, and its impact on the turnover intention with the moderating effect of perceived organizational support. A sample of 100 employees from ten five-star luxury hotels was selected for the study. A self-administered questionnaire with a five-point Likert scale was adopted and analyzed through Partial Least Square Structural Equation Modelling (PLS-SEM) and using Smart PLS 3 software. The results revealed that employees' awareness of smart hotels has a positive impact on their turnover intention. Further, the perceived organizational support significantly moderates the relationship between awareness of smart hotels and turnover intention. Therefore it is recommended that hoteliers need to adhere strategies to mitigate negative impacts of smart hotels and other technological applications such as by providing training, personal skills development, and technical skills development programs, and supporting employees to create positive opinions towards technological development.*

**Keywords:** *Employee Awareness on Smart Hotels, Perceived Organizational Support, Smart Hotels, Turnover Intention.*

## 1. INTRODUCTION

Hospitality industry together with tourism industry has been long identified as an emerging strategy which boost up the economies of developing world and currently being used in almost all developing economies (Ranasinghe, et al., 2020). In the context of Sri Lanka, the diversity of the country including natural, heritage, culture etc. have made the country a destination for numerous visitors. There by, the hospitality industry is in the cut throat competitive environment from very smaller city hotel to luxury resorts and hotels and even beyond. However, major brands are investing on creating unique experience to their guests.

This is being further fortified with the swift development of Information and Communication Technology in the recent decade, which has made its move towards almost all the manufacturing and service industries. Therefore, hospitality industry is also adopting a varying modes and facets of Information Technology. According to Siguaw, et al., (2000), the hotel owners are in the belief that through adopting technology, they could move up in the financial performance. And furthermore, especially the multinational group hotels are adopting cutting-edge technologies in creating a high tech image as a positioning strategy.

Moreover, the scholars have highlighted that guests expect to have a speed search for information which could help them in locating their destination to stay (Xiang & Gretzel, 2010), further, with the novel

---

\* Corresponding Author: E mail - [chathupiumika@gmail.com](mailto:chathupiumika@gmail.com)

technologies in rooms could increase their stay experience (Seric, et al., 2014) Thereby, the use of smart phones, high speed internet facilities and digital technologies are in the trend of hospitality industry. This has made the industry to interconnect both manual and automated technology. However, McClure, (2018) argued that despite the fact that the smart hotels are providing a unique experience to the guests, it is unquestionable that in coming future, innovative technologies could challenge the employments currently done by human as the Artificial Intelligence is able to handle a larger amount of information. Consequently, scholars have identified that the smart technology revolt and issues related to the challenge towards human jobs have created a fuss on employees moving them to think of an insecurity about the job. In order to face this challenge, they should first identify the impact that smart hotel concept create up on the employability of hospitality industry employees.

Therefore, the main objective of the study is to identify the relationship between employee awareness of smart hotels and their turnover intention and secondly, this study is to identify whether hotel employee's perceived organizational support moderates the relationship between employee's awareness of smart hotels and turnover intention. While many scholars have discussed on the smart hotels concept, the applications and the impact on the competitiveness, less have been discussed regarding the impact that it creates up on the turnover intention. Therefore, this research aims to fill this research gap with the application of scientific scales to understand the potential impacts on turnover intention. In here, a quantitative research study was conducted to further fill the empirical gap by gathering data from employees who are working in ten "five star rated luxury hotels" in Sri Lanka based on the tourist review website "TripAdvisor".

## **2. LITERATURE REVIEW**

### **2.1. Tourism Industry in Sri Lanka**

The tourism industry can be identified as one of the booming and fastest-growing industry accounting for 8% of the global GDP and 10% of employment (UNWTO, 2020). Considering the context of Sri Lanka, the tourism industry is considered as the third largest foreign income generator which accounts for the US \$4.4 billion in 2018 and the US \$3.7 billion in the year 2019 (SLTDA, 2019, 2020). Since the post-war period, the country was able to create a two-digit number of local and international tourists (Weerathunga, et al., 2020). Even though during 2019, the country was faced with the Easter bomb blasting it could earn a tourist arrival growth rate of 10.3% in 2018. (SLTDA, 2019).

With the popularity of the country as a best destination to travel in Asia, the accommodation sector including hoteliers were striving to provide necessary facilities for the influx visitors (Balint and Pop 2015). As a result, it could see an increase in the guests' nights in past ten years (SLTDA, 2019, 2020).

### **2.2. Smart Tourism and Smart Hotels**

'Smart' has become a popular buzz word which is used to refer for things which are driven by technological advancements, often economies, organizational operations etc. According to Harrison, et al. (2010), smart can be identified as smart as exploiting operational, near-real-time real-world data, integrating and sharing data, and using complex analytics, modelling, optimization and visualization to make better operational decisions. Smart tourism in this context is identified as, a social, cultural and economic phenomenon which entails the movement of people to countries or places outside their usual environment for personal or business/professional purposes (UNWTO, 2015).

However, smart tourism is certainly a diverse and one of important step forward of the tourism industry which made it go through evolution with the ICT an incorporate the business strategy with the new world. (Gretzel, et al., 2015). With the intervention of technology in tourism, the base of the transactions, the way of doing tourism business was faced with changes which made it come across various diversifications (Gretzel, et al., 2015). In a smart hotel, it integrates the usual hospitality operations, service offerings and other functions which are totally based in the innovative technologies incorporated with the information and communication technologies.

Also these take the service of the human employees to carry out the service functions which make the service more customer oriented to meet their demands (Jareman, et al., 2016).

Further, the scholars have identified the following attributes of a smart hotel: the availability of speed internet connection, Wi Fi, the application of smart technology with the usage of smart devices, management policies in distributing internet facilities, handling issues with smart applications, to make the room for developed ICT for the guests.

### **2.3. Employee Awareness of Smart Hotels (Ash)**

Powered by swift advances in computerization and digitalization, the use of robot technology, the use of AI technologies, (Syam & Sharma, 2018), with the birth of Industry 4.0, or else named as the fourth industrial revolution, has made significant changes in many service industries including hospitality industry, in moving them towards digitalizing their functions (Almada-Lobo, 2016). Yet, the scholars have elaborated that, with these developments and introduction of technology to hotel industry converting conventional hotels to smart hotels, could generate an impact of the employee relationships, the number of working hours, the time spend inside the workplace etc (Li, et al., 2019).

Nevertheless, new technology has become one of the aspects which create stress on employees in making much negative impact on work relations, employee relations, a feeling towards employment insecurity and also towards the turnover and less motivation and ambiguity of career growth as well (Brougham & Haar, 2018). In current scenario, the new technological trends have added a stress factor to their usual stressors such as family, work life etc, in making them adopted towards the changing technological arena. As such, the studies have discovered that, a considerable number of employees feel themselves less valued when their employers seek to integrate and replace their employees' work with new technologies.

Moreover, the researchers have identified that, there are negative effects created by the emerging smart technology in the several key outcome of h=jobs including organizational commitment, career satisfaction, etc. this is enhanced when the employees have awareness on technology, it creates negative relationship. This is further highlighted through the study of Brougham and Haar (2018) discovering that employees' smart technological awareness exhibited a significantly positive effect on intention to turnover.

Hypothesis 1 - Hotel employees' awareness of Smart hotels have a significant positive effect on their turnover intention.

### **2.4. Perceived Organizational Support (Pos)**

Rhoades & Eisenberger, (2002), inferred that POS reflects employees' belief on how much organizations support employees' work and welfare. Also, the study found that employees with higher Perceive Organizational Support, suffered less stress at work and were more likely to return to work recovered more quickly. And high POS is positively related to performance.

In some organizations, when the culture is much supportive for the employees, it allows the employees coordinate with the other employees and support them with the operations (Shanock & Eisenberger, 2006). Furthermore, the researcher argues that, employees that have very less organizational commitment, then the employees are much towards, quitting the organization.

### **2.5. Employee Turnover Intention (Ti)**

TI can be referred to as when the employees has created an intent to leave the workplace (Allen, et al., 2005). Also, the scholars have highlighted that when employees create an intention towards leaving, it directly creates a turnover. Employee Turnover Intention demands the organization to make more focus towards creating an employee centered culture, performance motivation, etc. (Collins & Smith, 2006). According to a study by Trevor & Nyberg, (2008), the turnover affects highly on creating the negative performance, reduce of the commitment, and the instability of the service offered by the employees. It



aligns with a study by Daghfous, et al., (2013), highlighting that the turn over intention affect the profit and the overall performance of the company.

Therefore, it is important that companies identify and understand the impact of turnover intention which effects on the overall organization performance (Addae, et al., 2006) because a higher turnover would make much critical aspects of the organizations.

As a labor intensive industry, when the turnover rates are very high, it could create a dramatic impact on the hotels because of which the hoteliers need to focus more in the turn over intention of employees.

## 2.6. Perceived Organizational Support and Turnover Intention

As Perceived Organizational Support reinforces employees' beliefs that the organization values their performance, the commitment towards the benefit of the organizations, and there by the employees in return will increase their commitment and attachment towards the organization (Rhoades & Eisenberger, 2002). Further the scholars also suggest that POS fulfils employees' socio-emotional needs (including approval, affiliation, and self-esteem) and develops a sense of unity with the organization, involve in and get the incorporation of organizational membership into their social identity.

Therefore, employees with a high level of POS highlights the stronger feeling of affiliation and attachment towards the working organization (Loi, et al., 2006) and reduce their motive to leave the employing organization (Wayne, et al., 1997).

Hypothesis 2 - perceived organizational support affects the strength of the relationship between hotel employees' awareness of smart hotels and turnover intention. Thus, the relationship is weakened when hotel employees perceive a high level of organizational support.

## 2.7. Conceptual Framework

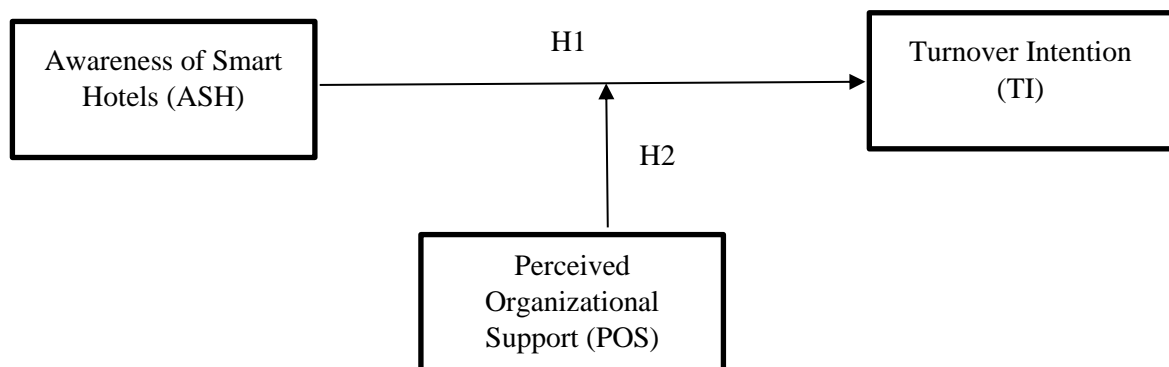

Figure 1: Conceptual Framework

## 3. METHODOLOGY

### 3.1. Population and Sample

The hotel industry of Sri Lanka represents the sample of the study as this industry recorded a broader spectrum in the application of sustainable business concepts (Melo & Galan, 2011). Thus, 100 samples was reached in this research and the respondents were selected from ten “five stars rated luxury hotels” in Sri Lanka based on the tourist review website “TripAdvisor”. Various employees from various positions within similar departments were selected as samples by using a simple random sampling technique from the above 10 hotels by taking approval from the HR department of hotels. In addition, the demographic information of the participants for this study identified that mainly these participants are male, the mean of the participant’s age level was 29.324 years. Further, the majority of the participants are diploma holders while have experienced between 5 to 10 years in the hotel industry.

### 3.2. Data Analysis

Required primary data for the study has been collected through a self-administrated questionnaire with a five-point Likert scale, scaling from “1” “strongly disagree” to “5” “strongly agree”. Employee awareness of smart hotels was recognized through four items taken and modified from the past study (Brougham & Haar, 2017), the Turnover intention was measured through six items were adopted from Pfeffer (2007), and Perceived organizational support has measured by using eight items adopted from Li, Bonn & Ye (2019).

### 3.3. Data Collection Method and Instrument

To measure and analyze the proposed theoretical/ conceptual framework, Partial Least Square Structural Equation Modelling (PLS-SEM) and SmartPLS 3. Statistical Software package was used to evaluate moderator impact. SmartPLS handles smaller samples compared with other statistical tools and it is suitable for build theories, extend the theories and apply the theories without normality assumptions of data distribution (Hair, Ringle & Sarstedt, 2013).

## 4. DATA ANALYSIS AND RESULTS

Table 1: Factor Loading Values and Operationalization

Dimensions	Factor Loadings
<b>Awareness of Smart Hotels (ASH)</b>	
ASH1 Think employee’s job could be replaced by smart technology	0.832***
ASH2 Worried that employee’s job tasks in job will be able to be replaced by smart technology	0.801***
ASH3 Worried about employee’s future in the current hotel due to smart technology replacing employees	0.875***
ASH4 Worried about employee’s future in hotel industry due to smart technology replacing employees	0.835***
<b>Perceived Organizational Support (POS)</b>	
POS1 Organization values employee’s contribution to its wellbeing	0.905***
POS2 Organization considers employee’s my goals and values	0.852***
POS3 Organization will help employee when they have a problem	0.924***
POS4 Organization really cares about employee wellbeing	0.897***
POS5 If employee decided to quit, the organization would try to persuade employee to stay	0.850***
POS6 Organization cares about my opinion	0.857***
POS7 Organization wishes to give the best possible job for which employee	0.927***
POS8 Employee’s supervisors are proud that employee is a part of the organization	0.905***
<b>Turnover Intention (TI)</b>	
TI1 Organization retention	0.965***
TI2 Feeling to leave	0.853***
TI3 Employee believes	0.846***
TI4 Intention of resigning	0.946***
TI5 Employee feelings	0.928***
TI6 Possible opportunities	0.892***

As per table 1, factor (outer) loadings of each indicator have taken to measure the reliability of the indicators. As recommended by Barclay et al (1995) it should accept indicators which are showing outer loading values more than 0.5 for the PLS measurement model. As per the table, it can be considered that, all the indicators which are reaching the 0.5 level have selected for the further analysis.

#### 4.1. Measurement Model

The measurement model of the study shows the association among the research constructs and the indicators. The composite reliability and Cronbach's Alpha has utilized to measure the reliability analysis of the measurement model. The accepted threshold value for both reliability values is 0.70 (Ringle, Sarstedt, Mitchell, & Gudergan, 2018). Accordingly, all the latent constructs in the model reach both composite reliability and Cronbach's Alpha criteria (Table 2).

The Average Variance Extracted (AVE) was used to measure the convergent validity of the measurement model and the desirable threshold value is 0.50 (Ringle, Sarstedt, Mitchell, & Gudergan, 2018). Hence all the constructs of the model possess convergent validity (Table 2). The method applied to measure the discriminant validity of the latent constructs in the measurement model is HTMT (Heterotrait Monotrait) ratio. Thus, the most accepted threshold value of the HTMT ratio is less than or equal to 0.90. Therefore all the HTMT values in this study were less than the accepted value and the discriminant validity of the latent constructs was attained (Table 3).

Table 2: Reliability and Convergent Validity of the Constructs

	Cronbach's Alpha	Composite Reliability	Average Variance Extracted (AVE)
ASH	0.846	0.872	0.534
TI	0.786	0.809	0.524
POS	0.720	0.813	0.569

Table 3: Discriminant Validity of the Constructs Using HTMT

	ASH	Moderating Effect 1	TI	POS
ASH				
Moderating Effect 1	0.280			
TI	0.250	0.238		
POS	0.232	0.307	0.860	

#### 4.2. Structural Model

The structural model of the study shows the relationships or the paths between the constructs of the study model. First, the direct effect between the ASH and TI was evaluated before introduce the moderating variable (POS) to the model. H1 evaluates whether there is a relationship between ASH and TI. The path coefficient results indicated that there is significant impact of ASH on TI ( $\beta = 0.355$ ,  $t = 4.692$ ,  $p = 0.000$ ). Therefore, H1 is supported. Consequently, the H2 access whether POS impact on TI. As per the results POS has effect on TI ( $\beta = -0.26$ ,  $t = 3.333$ ,  $p = 0.000$ ). Accordingly, H2 is supported (Table 4).

Table 4: Hypothesis Testing Using Path Coefficients

	Path Coefficients	Standard Deviation (STDEV)	T Statistics ( O/STDEV )	P Values
ASH -> TI	0.355	0.076	4.692	0.000
POS -> TI	-0.26	0.078	3.333	0.000

#### 4.3. Moderation Analysis

Moderation analysis was performed to identify the moderating impact of POS. Hence, H2 of the proposed model evaluates whether there is a moderating effect from POS on the relationship among ASH and TI. According to the path coefficient results, moderating effect of POS on ASH and TI is significant ( $\beta = 0.442$ ,  $t = 3.058$ ,  $p = 0.002$ ).

Table 5: Results of the Moderation Analysis

	Path Coefficients	Standard Deviation	T Statistics	P Values
<b>Moderating Effect 1 -&gt; TI</b>	0.442	0.145	3.058	0.002

## 5. DISCUSSION AND CONCLUSION

### 5.1. Discussion

Smart hotel is a new advancement of the hotel and it will be a groundbreaking concept in the hotel industry. Nevertheless, the existing literature in the hotel industry is not much-identified employees' awareness of smart hotels and their impact on their turnover intention. To fill that gap, the current research was developed to study the employee awareness of smart hotels on their turnover intention and also the role of employees' perceived organizational support in such relations. Based on the results, it has been identified that there is a positive relationship between ASH and TI in the hotel industry. Li et al. (2019) and Belete (2018) have identified the significant positive impact of ASH on TI from their studies. Therefore, this study provides compatible results with the findings of previous researches. In addition, the current study found a statistically significant negative impact of POS on TI. These results clearly demonstrate that the employee's POS leads to reducing their TI. When employees perceive more support from the hotels that they are working, they feel secure at their workplace and their turnover intention will be reduced. In addition, the findings of the research provide strong insight into moderating the impact of POS on the relationship between ASH and TI. According to the findings, POS has a statistically significant moderating effect on the relationship of ASH and TI. The results are positively consistent with past research findings of Li et al. (2019) and Alkahtani (2015).

### 5.2. Theoretical Implications

Rapid development of technology with smart technology, service automation, robots, and artificial intelligence, is fast growing at unparalleled way and it creates business opportunities, and they have been highly used in hospitality and travel and tourism industry (Ivanov & Webster, 2017). Generally, it will enhance service quality, improve communication and interactive methods, and improve the efficiency of business models in hotel industry. In the rapid pace of advancing the usage of smart hotel concept for hotel service automation, there can be the influence on employment between first line employees in hotels and it still need to be addressed. The current research supports to gain an understanding of the hotel employees' awareness of smart hotels and its impact on their turnover intention in hotel industry.

This research supports to theory related to employee awareness of smart hotels as a significant determinant of their turnover intention and this is one of the major challenge in the hotel industry. With the turnover intention in mind, employee productivity, their performance and their motivation will be reduced (Li, Kim, & Zhao, 2017). To face the challenge by reducing the employee turnover rate, hotels are required to recognize the main sources of turnover intention and try to give fullest support for employees to increase their enthusiasm and commitment to work (Kim, Lee, & Carlson, 2010). The current study contributes the theory on employee perceived organizational support weakens the strength of the relationship among ASH and TI and the study results have proved the moderating impact of POS to reduce the turnover intention of hotel employees. This proposes that, if the hotel employees receive sufficient appreciation and value for their commitment at work, they will be more energized and productive at their workplace.

### 5.3. Managerial Implications

Hotel managers and human resource professionals required to follow some strategies to mitigate negative impacts of smart hotel and other technological applications and they should conduct more research and development activities to identify the problems of replacing skilled employees by smart technology. Human resource professionals should understand the importance of provide training,

personal skills development and technological skills development programs, and support employees to create positive opinion towards technological development.

According to the study results, hotel managers can reduce employee's turnover intention will be reduced with all these organizational supports including communication development, team work, problem solving skills, leadership and motivation, creative and innovative thinking, interpersonal skills, time management and conflict management. Hotels should ensure the organizational support given to employees and create healthier organizational climate which leads to low turnover intention. They can improve internal communications by allowing employees to interact each other and participate friendly discussions and brainstorming sessions at meal breaks and tea breaks. Moreover, it will important to encourage employees to follow hobbies outside their work responsibilities to support their work-life balance. Apart from that, managers will make flexible workplace, better work arrangements and support employees at planning their works to create healthier organizational environment to reduce their turnover intention. As a recent trend of using smart technological applications in delivering hospitality services, it will convert all the processes smarter and more effective while retaining employees within the organizations.

#### 5.4. Limitations of the Study

The limitations of this research mainly lie in the lack of empirical exploration in Sri Lanka. The reason being, the smart hotel concept is not yet established in the country, the study results may subject to variations when the concept is being known and applied. Moreover, the study is focused only on the moderating role of perceived organizational support. Yet there may be many other factors moderating employees' turnover intention. Further, even though it is not intended, the majority of the respondents were male, which might have created an impact on the results.

#### REFERENCES

- Addae, H.M., Parboteeah, K.P. and Davis, E.E., 2006. Organizational commitment and intentions to quit: An examination of the moderating effects of psychological contract breach in Trinidad and Tobago. *International journal of organizational analysis*.
- Alkahtani, A.H., 2015. Investigating factors that influence employees' turnover intention: A review of existing empirical works. *International Journal of Business and Management*, 10(12), p.152.
- Allen, D.G., Weeks, K.P. and Moffitt, K.R., 2005. Turnover intentions and voluntary turnover: the moderating roles of self-monitoring, locus of control, proactive personality, and risk aversion. *Journal of Applied Psychology*, 90(5), p.980.
- Almada-Lobo, F., 2015. The Industry 4.0 revolution and the future of Manufacturing Execution Systems (MES). *Journal of innovation management*, 3(4), pp.16-21.
- Balint, C. and Pop, C., 2015. Romanian hotel industry profile through the traded hotel companies. *Procedia Economics and Finance*, 25, pp.332-343.
- Bandara, S.G.D.K., Abdeen, F.N., Disaratna, V. and Perera, B.A.K.S., 2020. Employee welfare and job satisfaction in the Sri Lankan hotel industry. *International Journal of Construction Management*, pp.1-10.
- Barclay, D., Higgins, C. and Thompson, R., 1995. *The partial least squares (PLS) approach to casual modeling: personal computer adoption ans use as an Illustration*.
- Belete, A., 2018. Turnover intention influencing factors of employees: an empirical work review. *Journal of Entrepreneurship & Organization Management*, 7(3), p.1000253.
- Brougham, D. and Haar, J., 2018. Smart technology, artificial intelligence, robotics, and algorithms (STARA): Employees' perceptions of our future workplace. *Journal of Management & Organization*, 24(2), pp.239-257.
- Collins, C.J. and Smith, K.G., 2006. Knowledge exchange and combination: The role of human resource practices in the performance of high-technology firms. *Academy of management journal*, 49(3), pp.544-560.
- Daghfous, A., Belkhodja, O. and Angell, L.C., 2013. Understanding and managing knowledge loss. *Journal of knowledge management*.

- Gretzel, U., Sigala, M., Xiang, Z. and Koo, C., 2015. Smart tourism: foundations and developments. *Electronic markets*, 25(3), pp.179-188.
- Hair, J.F., Ringle, C.M. and Sarstedt, M., 2013. Partial least squares structural equation modeling: Rigorous applications, better results and higher acceptance. *Long range planning*, 46(1-2), pp.1-12.
- Harrison, C., Eckman, B., Hamilton, R., Hartswick, P., Kalagnanam, J., Paraszczak, J. and Williams, P., 2010. Foundations for smarter cities. *IBM Journal of research and development*, 54(4), pp.1-16.
- Ivanov, S.H. and Webster, C., 2017. Adoption of robots, artificial intelligence and service automation by travel, tourism and hospitality companies—a cost-benefit analysis. *Artificial Intelligence and Service Automation by Travel, Tourism and Hospitality Companies—A Cost-Benefit Analysis*.
- Jaremen, D., Jędrasiak, M. and Rapacz, A., 2016. The concept of smart hotels as an innovation on the hospitality industry market-case study of Puro Hotel in Wrocław. *Zeszyty Naukowe Uniwersytetu Szczecińskiego Ekonomiczne Problemy Turystyki*, 36(4).
- Kim, B.P., Lee, G. and Carlson, K.D., 2010. An examination of the nature of the relationship between Leader-Member-Exchange (LMX) and turnover intent at different organizational levels. *International Journal of Hospitality Management*, 29(4), pp.591-597.
- Li, J.J., Bonn, M.A. and Ye, B.H., 2019. Hotel employee's artificial intelligence and robotics awareness and its impact on turnover intention: The moderating roles of perceived organizational support and competitive psychological climate. *Tourism Management*, 73, pp.172-181.
- Li, J.J., Kim, W.G. and Zhao, X.R., 2017. Multilevel model of management support and casino employee turnover intention. *Tourism Management*, 59, pp.193-204.
- Loi, R., Hang-Yue, N. and Foley, S., 2006. Linking employees' justice perceptions to organizational commitment and intention to leave: The mediating role of perceived organizational support. *Journal of occupational and Organizational Psychology*, 79(1), pp.101-120.
- McClure, P.K., 2018. "You're fired," says the robot: The rise of automation in the workplace, technophobes, and fears of unemployment. *Social Science Computer Review*, 36(2), pp.139-156.
- Melo, T. and Galan, J.I., 2011. Effects of corporate social responsibility on brand value. *Journal of brand management*, 18(6), pp.423-437.
- Pfeffer, J., 2007. Human resources from an organizational behavior perspective: Some paradoxes explained. *Journal of Economic Perspectives*, 21(4), pp.115-134.
- Ranasinghe, J.P.R.C., Danthanarayana, C.P., Ranaweera, R.A.A.K. and Idroos, A.A., 2020, May. Role of destination smartness in shaping tourist satisfaction: A SEM based on technological attributes in Sri Lanka. In *IOP Conference Series: Earth and Environmental Science* (Vol. 511, No. 1, p. 012001). IOP Publishing.
- Rhoades, L. and Eisenberger, R., 2002. Perceived organizational support: a review of the literature. *Journal of applied psychology*, 87(4), p.698..
- Ringle, C.M., Sarstedt, M., Mitchell, R. and Gudergan, S.P., 2018. Partial least squares structural equation modeling in HRM research. *The International Journal of Human Resource Management*, pp.1-27.
- Šerić, M., Gil-Saura, I. and Ruiz-Molina, M.E., 2014. How can integrated marketing communications and advanced technology influence the creation of customer-based brand equity? Evidence from the hospitality industry. *International Journal of Hospitality Management*, 39, pp.144-156.
- Shanock, L.R. and Eisenberger, R., 2006. When supervisors feel supported: Relationships with subordinates' perceived supervisor support, perceived organizational support, and performance. *Journal of Applied psychology*, 91(3), p.689.
- Siguaw, J.A., Enz, C.A. and Namasivayam, K., 2000. Adoption of information technology in US hotels: strategically driven objectives. *Journal of travel Research*, 39(2), pp.192-201.
- SLTDA. (2019). *Annual Statistical Report 2018*. Colombo. [Online] <https://www.slttda.gov.lk/en/annual-statistical-report> [Accessed 28 August 2021]
- SLTDA. (2020). *Annual Statistical Report 2019*. Colombo. [Online] <https://www.slttda.gov.lk/en/annual-statistical-report> [Accessed 28 August 2021]
- Syam, N. and Sharma, A., 2018. Waiting for a sales renaissance in the fourth industrial revolution: Machine learning and artificial intelligence in sales research and practice. *Industrial Marketing Management*, 69, pp.135-146.

- Trevor, C.O. and Nyberg, A.J., 2008. Keeping your headcount when all about you are losing theirs: Downsizing, voluntary turnover rates, and the moderating role of HR practices. *Academy of Management Journal*, 51(2), pp.259-276.
- UNWTO Annual Report 2020. [Online] Available at: <[https://www.wto.org/english/res\\_e/publications\\_e/anrep20\\_e.htm](https://www.wto.org/english/res_e/publications_e/anrep20_e.htm)> [Accessed 26 September 2021].
- Wayne, S.J., Shore, L.M. and Liden, R.C., 1997. Perceived organizational support and leader-member exchange: A social exchange perspective. *Academy of Management journal*, 40(1), pp.82-111.
- Weerathunga, P.R., Xiaofang, C., Samarathunga, W.H.M.S. and Jayathilake, P.M.B., 2020. The relative effect of growth of economy, industry expansion, and firm-specific factors on corporate hotel performance in Sri Lanka. *SAGE Open*, 10(2), p.2158244020914633.

# Tourism Promotion in Sri Lanka Using Landscape and Scenery Photography

U.A. Dhanusha Premarathna<sup>\*1</sup>, M.M.K.S. Dissanayake<sup>2</sup>

<sup>1</sup>Division of Management studies, University College of Ratmalana, Sri Lanka

<sup>2</sup>Division of Television studies, University College of Ratmalana, Sri Lanka

## ABSTRACT

*This study has been investigated the usage of still photography of landscapes and sceneries for tourism promotions in Sri Lanka. Sri Lanka Tourism Promotion Bureau launches several campaigns annually, to promote tourism by using landscape and scenery photographs in a variety of modes in print, digital, and print media. With the literature evidence, photography has a significant role in promotion as an interconnecting tool in advertising. The study has been conducted to comprehend the qualitative improvements required for still photography on tourism promotions. Hence, the study has been implemented under the qualitative approach to achieve the research objective mentioned above. By limiting landscape and scenery tourism promotion by still photography in Sri Lanka as a single case, the case study research design has been implemented in this study. The sample population includes resource persons from the subject areas of tourism management, marketing & management, photography, and psychology defined through purposive and convenience sampling techniques. 23 qualitative semi-structured interviews were conducted to collect primary data. Essential factors to be considered during capturing touristic objects using suitable camera angles and composition for tourism promotions and creative new ideas for utilizing photographs for tourism promotions were identified through the data analysis.*

**Keywords:** Advertising, Composition, Photography, Promotion, Tourism.

## 1. INTRODUCTION

Tourism and photography are interdependent two components which have an inseparable relationship since the part & parcel role of photography in day-to-day life (Gogoi, 2014). During travel any travel destination where ever in the world any type of tourist loves photographing of sceneries, landscapes, touristic objectives, monuments, festivals & events and human attractions of the travel destinations to fulfil several needs. Tourists are taking photographs as a memory of traveling (Gogoi, 2014) as well as evidence of their actual visit in a particular travel destination. As a promotional tool; the stream of advertising peopled by fantastic attractive photographs (Scott, 1994). In the Sri Lankan context, there are several milestones of utilizing still photographs related with tourism activities of tourists and promotional activities from the British colonial period (Gunasekara, 2012). With the booming trends of social media sites including Face book, many individuals are engaging on destination promoting by sharing variety of still photographs via social media by using several editing tools and several views of destinations. When consider camera equipment, composition, camera angle and other qualitative factors of those photographs sharing on social media; which are reflecting Sri Lanka's scenic beauty, variety of positive and negative factors can be identified. As per the preliminary studies done related with this matter, it has been observed that there is huge gap between the sceneries reflecting on photographs and the actual scenery of the destination due to inadequate of camera equipment, composition, camera and angle; which may negatively impact on tourist attraction. Therefore, this study has been implemented to understand the fundamentals of utilizing still photographs for tourism promotional activities with the special attention on landscape and scenery photographing in the Sri Lankan context.

## 2. LITERATURE REVIEW

'Photography', meaning 'writing with light' was perhaps never a sufficient neologism to describe the totality of the technology (Romer, 2010). Before the invention of photography and relevant technologies

---

\* Corresponding author: E mail: [dhanushaprem@gmail.com](mailto:dhanushaprem@gmail.com)



in the world, the ancient human had the behaviour of communication by symbols and drawings from the earlier period when they have invented ‘alphabets’ and writings (Palliyaguru, 2010). Edwards (2020) has discussed the history of photography and its significant milestones effected on business industry. As an element of marketing mix, promotion can be defined as a persuasive communication of a marketer with its target market to achieve marketing objectives (Chaudry, 2010). As a promotional tool, ‘advertising’ and photography has a strong relationship; as per the view of Allers (1997), photographs must full fill the client's needs when they are utilizing in advertising to create imaginative attractiveness of particular advertising (Allers, 1997). In a print advertisement, the communicator or the marketer has to decide the factors may enhance the attractiveness; use of novelty and contrast, eye-catching pictures, colours, shapes, distinctive format, headlines and movements (Kotler and et al, 2018). According to Raju (2021), advertising photos should be in high-quality and eye-catching to deliver brand’s message through customers engaging with the advertisement. Inspires purchase decision is one of fundamental fact highlighted by the author, when describes the significance of photography in advertising (Raju, 2021). Gogoi (2014) has described the relationship between tourism and photography by three broad heads as photography as a medium of capturing and preserving memories, ‘Photographic Tourism’ as a new dimension to the existing tourism industry and photography as a tool for promoting tourism products and destinations. According to Beerli & Martin cited by Govers and Kumar (2007) tourism destinations use promotion and marketing communication strategy to influence destination image. As per the study done by Hunter (2008) with tourism perspective; in the marketing field, photographic images have become the perfect medium to promote a tourism destination by using still photography in travel brochures, postcards and guidebooks to influence travel decisions (Hunter, 2008).

According to Gunasekara, the still photographs have been used by the British Governments for several reasons as; to conduct archaeological surveys in ancient Ceylon, to photographing the travels of royal family members in Ceylon, to share scenic beauty of Ceylon among European residents via picture post cards and to fulfil the requirement of British Government (Gunasekara, 2012). “My purpose is to arable the friends of European residents in Ceylon, and other who are interested in the Island, to obtain a better idea of its charming features than possible from mere verbal description” (Cave, 2002). The objective of Cave’s publication in 1910 was, to communicate the scenic beauty of ancient Ceylon by photographs better than a verbal description. Kaewnopparat (2017) has examined the effects of colors and tones of photographs in tourism contexts by focusing on beach photographs in Thailand. Findings are based on hue composition and controls for scene composition by the response of visual style of color tones. The study done by Herath (2020) has explored the concept of responsible photographic representation of travel destinations. The study has suggested the visual communication of travel destinations’ authenticity and the unique experience tourists can have paramount in developing a unique destination image. The study has not investigated the factors regarding other sensitive geographical locations considered as travel destinations. Cox (2020) emphasize that how important to have a suitable camera for capture photos.

### **3. THE RESEARCH PROBLEM**

The literature review of this study investigates the term "photography". It also explains the usage of photography in business as a promotional tool. Further, the literature study also investigates the milestones of using visual images to communicate a message and usage of photography in tourism industry to develop destination image. The literature survey does not address on fundamental factors on camera techniques and composition to be utilized when capturing photographs for tourism promotions to build up destination image. Hence, this study focuses on identifying the essential factors on camera techniques to be considered during capturing landscape and sceneries by appropriate angles. Therefore, the researcher has taken the opportunity to investigate the issue; what are the suitable composition and camera angle to capture qualitative photograph for tourism can be adapted for utilizing photographs for tourism promotions by limiting to landscape and scenery photography.

#### 4. OBJECTIVE OF STUDY

The researcher has investigated the knowledge gap of specific qualitative practices should be followed when process a still photograph for tourism promotion. As per the findings of preliminary qualitative studies done in the subject area and the findings of the literature survey, the researcher has developed the two research objectives of this study as; to identify suitable camera equipment and its techniques on usage with composition for still photography on tourism promotions and to understand new concepts to utilize still photography on tourism promotion.

#### 5. METHODOLOGY

Mohajan (2018) describes the preference of qualitative researchers while studying the factors related with human beliefs and experiences as, “Qualitative researchers are interested in people’s belief, experience, and meaning systems from the perspective of the people” (Mohajan, 2018). The qualitative research is approachable to provide details about human behaviour, emotion, and personality characteristics that quantitative studies cannot match (Madrigal and McClain, 2012). To understand the impressions of participants is a fundamental fact in this study and the qualitative research approach is more supportive rather than questionnaire-based quantitative research approach to study the real impression about usage of still photography in tourism promotion. With considering those factors, this study has adopted qualitative research approach to gain the cognitive and emotional views of the respondents to identify required qualities when process and utilize still photographs on tourism promotion under the case study research design.

##### 5.1 Population and Sample

In qualitative approach, researchers tend to use nonprobability sampling to explore deeper their initial understanding of the phenomena that they are studying which not all members of the population have a chance of participating in the study, unlike probability sampling (Ishak and Bakar, 2014). This study has been adopted multiple sampling methods including purposive sampling technique and convenience sampling technique for the primary data collection. The population of this study was included university level’s students who were studying tourism management, marketing & management, photography and psychology and employees in academic sector who were represent tourism and photography defined through the purposive sampling technique for applying expert knowledge of those subject areas. The convenience sampling technique was adopted to recognize participants for the primary data collection conducted by qualitative interviews with considering where members of the target population’s availability at a given time and the willingness to participate (Atikan, Musa and Alkassim, 2016) for the primary data collection.

##### 5.2 Data Collection and Data Analysis

Primary data of this study has collected by qualitative interviews. Qualitative interviews were supportive to explore experiences, views, opinions, or beliefs on specific matters of the sample regarding tourism and photography which are supportive to achieve research objective. The semi-structured interview method allows the opportunity on the part of the interviewer to investigate and expand the interviewee's responses. Thus, the researcher adopts the semi-structured interview including 11 main interview questions which covered an amalgamation of photography techniques, tourism and marketing subject streams for this study to investigate research the research objective. When it has conducted 23 semi-structured interviews, the researcher has observed that the patterns and types of answer types has reached the saturation point of this study. There were no previous built theories founded through the literature study related to the study therefore, the qualitative data was analyzed under inductive analysis approach. Under the inductive analysis approach, the researcher has adopted the content analysis method to determine the existence of certain words, themes, or concepts within qualitative data from interviews and field observational reports. The content analysis method was supportive for the researcher to identify the meanings, focus or communication trends of the respondents during the interviews.

## 6. FINDINGS AND DISCUSSIONS

### 6.1 The Composition of Landscape Photographs

Cox has emphasized that, the photographer cannot predict the exact path of a viewer's eye through the photographs, but he has the ability to nudge it towards one object or another by using appropriate techniques in composition (Cox, 2020). According to Adorama (2020), some of the most commonly practiced photography composition techniques can be stated as; *Simplification*- to determine the focal point of the image; *Filling the Frame*- to focus the object attractively for the viewer; *Rule of Thirds*- the technique based on the idea that placing the subjects' off-centre yields a stronger with more natural-looking; *Framing*- the technique involves using or adding frame elements to emphasize and lead the viewer's eye towards the subject to add interest to the image; *Colour*- the use of colour in photograph to create magnificent and strengthen the message behind through images; *Contrast*- to surround the subject and fill the frame with lighter colours; *Leading Lines and Shapes*- to lead viewer's eyes to the subject by lines and shapes; *Symmetrical Balance*: to create the visual balance of image; *Asymmetrical Balance*- to balance the composition by including two different or contrasting subjects or elements. When it considers about tourism billboard advertising in Sri Lanka, one respondent has been mentioned the issues of bill boards. The billboards contain more images and other details without proper balancing. The images have no attractiveness. Therefore, they are not more attractive when passing them by a vehicle, as per the view of the respondent. According to Hussain and Nizamani (2011) cited by Khan (2016) regarding billboard advertising, the size of boards, colours used in the board, locations and the images selected in the boards does matters for gaining the attentions of the audience/customers (Khan, 2016). The findings of this study suggests to enhance the composition of images during billboard promotions and other printed and social media base tourism promotions with considering techniques of composition.

### 6.2 Usage of Camera Settings for Still Photography on Tourism Promotion

Shaw (2020) has described five essential camera effects for modern photography as; ISO (measure of the sensitivity of camera's digital sensor to light); Shutter speed (the length of time of camera's sensor is exposed to light); Aperture (the size of hole in the lens); White balance (balance colour of the light, rather than its brightness) and Exposure compensation (determining the proper exposure level). Among these five effects, this study has been investigated the usage of 'slow shutter speed motion- camera effect' when photographing natural water movements like waterfalls. Choosing a shutter speed one step slower than the current shutter speed (for example, by changing shutter speed from 1/125 s to 1/60 s) is referred to as "slowing shutter speed by one step" and doubles the amount of time the shutter is open (DSLR Camera basis, n.d).

According to the view point of 18 participants, when photographing destination attractions with natural scenic beauty like waterfalls and any sceneries with movements of water in 'slow shutter speed motion' may decrease the attractiveness of the photography with tourism perspective. 'Slow shutter speed' is a popular concept in the art of photography; these are images that probably don't exist in the real world, as viewed through a pair of normal eyes; but with a slower shutter speed a photographer can create beautiful, artistic expressions that otherwise might have never been seen (Slagle, n.d). Three interviewees who have the subjective knowledge of photography have explained the fundamental usage of this camera setting in creative photography but, it is not much more fitting with the perspective of tourism promotion. Promotion is considered the set of marketing techniques or a form of communication to capturing the attention and by attracting potential customers (Alexandrescu & Milandru, 2018). Therefore, as a communication tool in tourism photography, there is minimal opportunity to implement more effects using camera settings which can be damage the actual view of the destinations. As per the views of interviewees who represented photography and marketing streams; a photograph able to communicate a massive scale of information within very shorter time period rather than communicating a message by a typographical manuscript. The advertisings include still photographs with stopping power to attract target audiences to communicate messages within a short time.

The majority of participants have emphasised that, photographing destination attractions like waterfalls by ‘Slow shutter speed’ camera effect may damage the actual view of the object and it may influence on the less travel motivations of the tourists but, the participants have accepted the importance of appropriate usage of above mentioned camera effects and ‘colour grading’ as an editing effects to enhance the attractiveness of the photograph. Such editing should not be exceeded the natural view of the photograph to attract tourists.

### **6.3 The Camera Angles of the Main Objects when Photographing for Tourism Promotion**

Camera angles include as; ‘Eye angle’, the most neutral camera angle which represents the eye view level; ‘Low angle’, which might be used to convey a sense of authority; ‘High angle’, which creates the opposite impression of the low angle; ‘Bird view or top view’, which provides an aerial view (Sudhakaran, et al, n.d). The findings of Baranowski<sup>1</sup> and Hecht (2017), elaborate the effectiveness of the ‘Eye angle’ photography as communicating to someone at eye-level. 11 interviews of this study have explain the importance of the ‘Eye angle’ view still photographs when utilize them for tourism promotion which provides a familiar view of a travel destination’s scenic view which is quite similar to the view they can see when they visit real. Tourist can see through an ‘Eye angle’ photograph the real environmental view of the destination and such photographs can provide a positive level of first impression of a destination. 9 participants of the interviews reasoned the significant of ‘Low angle’ photography and ‘Bird view’ photography for tourism promotion as; when capture a tourist attractive object such as a monument, waterfall or mountain cliff by the ‘Low angle’ it may provide a positive personality of the object with strong impression rather than the ‘Eye angle’ view of a particular object to be promoted. ‘Bird view’ photographs which can be captured by drone shots able to provide a broad range of details of the destinations rather than other views, as per the viewpoints of 2 persons who have recommended ‘Bird view’ photography as a tool to communicate overall details of a tourist destination to fulfil tourists’ information needs.

Worms’s eye view photography is a point of view in photography where the image is captured from a very low angle with camera pointing towards the top which is equals the view from a worm’s eye in the ground (Vijayakumar, 2020). According to Vijayakumar (2020), photographs captured from warm eye viewpoint will look more beautiful in wide-angle frames (18mm to 25mm range). Hence, the author is recommended warm eye view photography to capture unique and attractive captures during wildlife photography, astrophotography, cityscape photography and forest-scape photography to better capture shapes and patterns by different Image Composition Techniques. Two interviewees of this study have been highlighted the attractiveness of warm eye view scenic photography including waterfalls, mountains or rock cliffs as a potential utilization for Sri Lankan tourism promotions which may not more popular in the Sri Lankan context.

### **6.4. Appearance of Human Activities in Scenery Photographing for Tourism Promotion**

Majority of participants negatively described the appearance of human activities in natural scenic photographs of tourism promotion as a decreasing factor of the attractiveness. Appearance of too much human activities in a scenic photograph create the disturbance to read the main details of the photograph. The study done by Höckert and Lüthje (2018) has elaborated the significance of gaze and face of tourism photography with the perspective of tourists’ photographing during the traveling. Several interviewees have described the attractiveness of human appearance when promotes travel destinations which are linked with touristic activities like hiking, trekking, white water rafting, nature trails, outdoor camping and etc. but, as per the recommendations of the findings; such human activities should not be interrupted the visual quality of the photograph. At the image level, the scenic quality should be included the aesthetically and symbolically interpreted appearance of landscape as a fundamental fact when it considers about visual quality (Roth and Gruhen, 2005). According to the findings of the existing study; there is no disturbances capture human appearances on scenery photographing for tourism promotion without the disturbing the visual quality of the images. The findings of Herath’s study (2020) have recommended the appearance of human activities which are reflecting local communities’ life styles and their rituals with the concept of responsible tourism photography.

## 6.5 Creative Ideas to Utilize Still Photograph for Tourism Promotional Activities

The creative utilizing of the concept of 'photo installation' on tourism promotion is one of essential finding under this. Photo installation is an art of immersion or an artistic by installing photographs with entirety of the vision in new shape to create a greater response in a viewer (Thompson, 2016). Switzer (2019) has explained the concept as an art which is not presenting the reality at all but as a concept of 'photography into sculpture'. The findings of primary data have elaborated the importance of the concept of photo installation when using for tourism promotions at touristic events including trade fares, tourism roadshows, and exhibitions and in airport terminals since the exhibit quality of a photo installation in a physical space. Not like typical tourism promoting with photographs in printed media; in this approach the viewer can physically enjoy the installation as an exhibit object with an enhanced curiosity. During the study, Switzer (2016) has introduced several themes of installations including tree, puzzle and house matching with the areas of photo collections. With that basis of literate and the findings of primary data, the photographer has the possibility on developing photo installations for tourism promotions as per key branding themes of a travel destination. The findings of the existing study have described the importance of photo installations for tourism promotions as well as few interviewees have reasoned the limitations of the concept. Since an art of photography, tourism photo installations may not effective in tourism promotions to target every tourist market. Thus, the promoter should decide the most suitable markets for this type of promotion. Further, the findings have emphasized the importance of 'photomontage'. A photomontage is a series of individual photographs captured at one location which have installed under one subject and arrange them together to create a single image (Johan, 2020). According to the findings, a photographer able to creatively utilize 'photomontage' technique for tourism promotions to elaborate; the different seasonal views of a scenery, to elaborate different views of touristic objects like waterfalls and mountains and to explain different human activities in a particular destination by one image. Such creative opportunities may depend on the limitations of photographic tourism promotions in the Sri Lankan context.

## 7. CONCLUSION

Photographing is an effective promotional tool for tourism industry. Still photography is an effective mode to communicate travel information for tourists within a shorter time rather than sharing information by a typographical text. Optimal usage of composition techniques which not exceeding the natural visual quality of scenic scenes' photographs; usage of 'eyelevel', 'low angle', and 'worm eye angle' views to capture touristic objects; careful utilizing of typography and human appearance on still photographs and implementing new photography concepts & techniques are the key highlights of this study when utilize still photography on tourism promotion. The photographer has to be involved in optimal level when decide promotional needs, capture required photographs and process to enhance the qualitative aspects of tourism promotional still photographs. This study suggests to implement more studies for future researchers to further investigate on limitations and issues have identified in this study. As the head of responsible institute on tourism promotions in Sri Lanka the Sri Lanka Tourism Promotion Bureau may be able to obtain effective outcomes of tourism promotions by still photography by implementing the findings have discussed in this paper.

## REFERENCES

- Adorama, 2021. *11 Photography Composition Techniques to Improve Your Photos*. [Online] Available at: <https://www.adorama.com/alc/basic-photography-composition-techniques/>
- Alexandrescu, M. B., & Milandru, M., 2018. Promotion as a form of communication of the marketing strategy. *Land Forces Academy Review*, pp. 268-274.
- Allers, I., 1997. *Advertising Photography: Report* (National Diploma). Central University of Technology.
- Baranowski, A. . M. & Hecht, . H., 2017. Effect of Camera Angle on Perception of Trust and Attractiveness. *Empirical Studies of the Arts*, pp. 1-11.
- Cave, H. W., 2011. *Ceylon along Rail Track*. 3 ed. Nugegoda: Visidunu publishers.
- Chaudhary, M., 2010. *Tourism marketing*. New Delhi: Oxford Univ. Press.

- Cox, S., 2020. *Introducing Composition in Photography*. [Online] Available at: <https://photographylife.com/introducing-composition-in-photography>
- DSLR camera basics*. Nikon. (n.d.). Retrieved August 28, 2021, from <https://imaging.nikon.com/lineup/dslr/basics/04/03.htm>.
- Edwards, S., 2020. Why Pictures? From Art History to Business History and Back Again. *History of Photography*, pp. 3-15.
- Etikan, I., Musa, S. . A. & Alkassim, R. S., 2016. *Comparison of Convenience Sampling and Purposive Sampling*. American Journal of Theoretical and Applied Statistics, 5(1), pp. 1-4.
- Gogoi, D., 2014. A Conceptual Framework of Photographic Tourism. *International Journal of Research in Applied Natural and Social Sciences*, pp. 107-112.
- Gunasekara, U. G., 2012. *śrī lāmkēya cāyārūpa varṁśaya*. Nugegoda: Sarasavi.
- Herath, H., Hemmington, N. & Poulston, J., 2020. “Dirty pictures” – responsible photographic representation of tourism destinations. *Journal of Travel & Tourism Marketing*, 37(6), pp. 663-678.
- Höckert, E., Lüthje, M., Ilola, H. & Stewart, E., 2018. Gaze and Face in Tourist Photography. *Annals of Tourism Research*, pp. 1-21.
- Hunter, W. C., 2008. A typology of photographic representations for tourism: depictions of groomed spaces. *Tourism Management*, pp. 354-365.
- Ishak, N. M. & Bakar, A. Y. A., 2013. *Developing Sampling Frame for Case Study: Challenges and Conditions*. World Journal of Education, pp. 29-35.
- Johan, K. L., 2020. *Photomontage: What Is It and How to Make One Yourself*. [Online] Available at: <https://expertphotography.com/photomontage-definition-ideas/>
- Kaewnopparat, J., 2017. *The Impact of Photography on Tourism: Photography The Impact of Photography on Tourism: Photography Construction Perspective*. Thesis (PhD). University of Tennessee..
- Khan, H., 2016. Billboard Advertising and Customer Attention: A Pakistani Perspective. *International Journal of Scientific and Research Publications*, 6(3), pp. 502-506.
- Kotler, P. T., Bowen, J. T., Makens, J. & Baloglu, S., 2018. *Marketing for Hospitality and Tourism*. Noida: Pearson Education.
- Le, B., 2016. *What is Photo Manipulation?*. [Online] Available at: <https://ipiccy.com/blog/what-is-photo-manipulation/>
- Madrigal, D. & McClain, B., 2012. *Strengths and Weaknesses of Quantitative and Qualitative Research*. [Online] Available at: <https://www.uxmatters.com/mt/archives/2012/09/strengths-and-weaknesses-of-quantitative-and-qualitative-research.php>
- Mohajan, H., 2018. Qualitative Research Methodology In Social Sciences And Related Subjects. *Journal of Economic Development, Environment and People*, pp. 1-29.
- Nufer, G., 2013. Guerrilla Marketing—Innovative or Parasitic Marketing?. *Modern Economy*, pp. 1-6.
- Palliyaguru, C., 2010. chāyarūpa kalāvē viśeṣatvaya- tākṣaṇayāta sīmā novana cāyārūpa kalā sankaplanaya. *Prabhā lēkhana samhitā*, pp. 13-18.
- Raju, R., 2021. *The importance of advertising photography*. [Online] Available at: <https://www.splento.com/blog/photography/the-importance-of-advertising-photography/>
- Romer, G. B., 2010. *Fundamentals of the Conservation of Photographs*, Los Angeles: The Getty Conservation Institute.
- Roth, M. & Gruhen, D., 2005. Scenic Quality Modelling in Real and Virtual Environments. pp. 1-11.
- Scott, L. M., 1994. Images in Advertising: The Need of Theory of Visual Rhetoric. *Journal of Consumer Research*, pp. 252-273.
- Shaw, D., 2020. *The Five Most Essential Camera Settings and How to Use Them*. [Online] Available at: [https://digital-photography-school.com/essential-camera-settings/#dps\\_comments](https://digital-photography-school.com/essential-camera-settings/#dps_comments)
- Slagle, A., n.d. *Slow Shutter Speed Photography*. [Online] Available at: <https://www.picturecorrect.com/tips/slow-shutter-speed-photography/>
- Sudhakaran, P. et al., n.d. *15 Essential Camera Shots, Angles and Movements*. [Online] Available at: <https://wolfcrow.com/15-essential-camera-shots-angles-and-movements/>
- Switzer, S., 2019. Working With Photo Installation and Metaphor: Re-Visioning Photovoice Research. *International Journal of Qualitative Methods*, pp. 1-14.

- Thompson, R., 2016. *Installation Photography and the transportation of the viewer*. [Online] Available at: <https://www.donttakepictures.com/dtp-blog/2016/3/1/installation-photography-and-the-transformation-of-the-viewer>
- UNWTO, n.d. *Wildlife is our world heritage*. [Online] Available at: <https://www.unwto.org/asia/unwto-chimelong-why-wildlife>
- Vijayakumar, G., 2020. *Worms Eye View Photography – How, What & Tips*. [Online] Available at: <https://www.photographyaxis.com/photography-articles/worms-eye-view-photography/>
- Wiener, A. Z., 2021. *What Is Guerrilla Marketing? 11 Examples to Inspire Your Brand*. [Online] Available at: <https://blog.hubspot.com/marketing/guerilla-marketing-examples>
- Yuksekbilgili, Z., 2014. The Use of Guerilla Marketing In SMEs. *International Journal of Advanced Multidisciplinary Research and Review* , pp. 2-7.

## **INDUSTRIAL MANAGEMENT THROUGH INNOVATIVE TECHNOLOGIES**



# An Analysis of the Relationship between High Tech Exports and Unemployment

S. Niroshanth\*

Department of Software Technology, University of Vocational Technology, Sri Lanka

## ABSTRACT

*This empirical study analyzes the relationship between high tech exports and unemployment. The study is conducted only thirteen years for the period of 2007 – 2019. The data set of high technology exports (% of manufactured exports) and unemployment total (labor force (percentage) – modeled International Labor Organization (ILO) estimate) was gathered from The World Bank. We use covariance analysis, correlation analysis, and cointegration to achieve the goals of this study. The Matrix form of Covariance analysis and Ellipse, Kernel fit of correlation analysis were used it. It was found there is no significant direction between high technology exports and unemployment total. The Augmented Dicky Fuller test has confirmed that those variables were stationary at logarithm first difference. At the same time, the residual series was non-stationary at level form. Therefore, the researcher concludes that there is no long-run relationship between high technology exports and unemployment and the changes in high-tech exports do not affect unemployment worldwide. So, researchers need to find other technical indicators for how to determinant unemployment. Future studies want to find short-run and causality between those two variables and want to include more.*

**Keywords:** *Cointegration, Correlation, Covariance, High Tech Export, Unemployment Rate.*

## 1. INTRODUCTION

Today the use of technology-based products around the world is seen as an unavoidable one. Every country is expecting the goal of rapid technological advancement. The term technology defines, Commercial and industrial goals are related with scientific technique and materials (Kasemsap, 2017). In other words, Technology is the development and application of technological means based on a portion of the knowledge about life, society and their interaction with the environment (Kasemsap, 2016). Technological development is intended to be progressive. It is necessary to examine whether this progress affects social welfare or not. Technology-based research areas have been conducting in-depth studies on this in recent years.

Social welfare is included empowerment, health care, better housing and welfare programs that help the poor, the unemployed and the destitute in the community (Walden University, 2021). That is why the concept of unemployment is so important in social welfare indicators. Unemployment is playing an essential role in the whole world. It refers to people who can work and are actively looking for work but cannot find work (CFI, 2015). Rajaguru and Gaston (2010) find, higher prices for exports, capital growth in the production of commodities and lower unemployment reduce the equilibrium unemployment rate. It was a big issue regarding the development approaches. It is very much clear from the review export and unemployment is growing with time but still not investigated the relationship between high tech export and unemployment total.

Figure 1 shows the high technology exports of the world from 2007 to 2019. It was volatile between the years 2007 to 2017. After it was suddenly increased in 2018. Then it has dramatically decreased. Figure 2 show that, unemployment total labour force worldwide. It was suddenly increased in 2009. Because, the global financial crisis has sharply increased unemployment across the world (IMF News, 2010).

---

\* Corresponding Author: E-mail - [niroshanth929@gmail.com](mailto:niroshanth929@gmail.com)

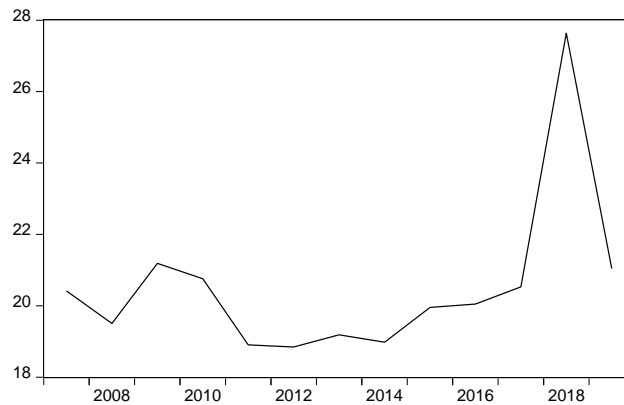

Figure 1: Worldwide High Technology Exports in percentage of Manufactured Exports (2007 – 2019)



Figure 2: Worldwide Unemployment Total in percentage of Total Labor Force – Modeled International Labor Organization Estimate (2007 – 2019)

Commonly high-tech products are used the human knowledge to the production process. It was reducing the importance of humans in that process. The relationship between technology and employment has long been debated. Changes in employment-related status also occur during the period of technological intensive development. The issue is therefore one that needs to be debated (Vivarelli, 2015).

Therefore, this study attempts to examine the relationship between high-tech exports and unemployment total of the world from 2007 to 2019. So, the research questions are:

Is there any relationship between those two variables?

What is the strength of relationship between those two variables?

Do high tech exports impact the unemployment in long term?

Thus, the study focuses on the three objectives as;

To find the relationship between those two variables.

To analyze the strength of relationship between those two variables.

To find out whether the high-tech exports impact the unemployment in long term.

The study attempts to fill the gap of many previous studies which analysed the relationship with technology and unemployment and to find the relationship between exports and unemployment. The study especially focused on how high-tech exports affect unemployment. This study used the econometrics techniques and

used the E-views software to identify the goals. And also, this analysis considers the world-wide status on this topic.

## 2. LITERATURE REVIEW

Moreover, studies found a significant relationship between exports and unemployment. Ozughalu and Ogwumike (2013) found that there was a long-term link between unemployment, real GDP, real foreign direct investment and real exports. But real GDP and real foreign direct investment have not reduced unemployment in Nigeria (1984 – 2010). Johansen co-integration test and Granger causality test methods were used by them to their findings. Aktar and Ozturk (2009) argued In Turkey between 1985 and 2008, they were found that there was a long-term relationship between unemployment and GDP, exports and foreign direct investment, and that economic growth and foreign direct investment and exports generally did not reduce unemployment.

Yılmaz Bayar (2014) examined the relationship between unemployment, economic growth, exports and foreign direct investment in Turkey between 2000: Q1 - 2013: Q3. They used bound testing approach based on autoregressive distributed lag. They also found that there is a long-term link between economic growth, exports and foreign direct investment inflows. Ismail Aktar et al (2008) was studied the impact of foreign direct investment, exports and economic growth on unemployment in Turkey from 1987 to 2007. Johansen cointegration technique has been used to detect long-term contact. They suggest that there are two cointegrating vectors during the research period of time in Turkey.

KhairulAmri, & Nazamuddin. (2018) find the relationship between the export and employment creation in Indonesia in 1987 – 2013. They conclude in long term there is no relationship between employment and export. In a short-run, the employment positively and significantly causes the export. They used Vector autoregressive and Granger causality test.

## 3. METHODOLOGY

Time-series data were used in this study from 2007 to 2019. This study makes use of annual data. The data set include two variables. Worldwide High technology exports in percentage of manufactured exports and unemployment total in percentage of the total labor force (modeled International Labor Organization estimate) data were obtained from The World Bank. We got the all outputs of the estimation using the econometric software E-views-10.

## 4. RESULTS AND DISCUSSION

### 4.1. Covariance

Covariance is a measure how to two random variables differ together. It is finding the direction of a linear relationship between two variables. So, we check the covariance Analysis by the Matrix approach. In the output of covariance matrix, the off-diagonal elements explained the covariance of each pair of variables. The diagonal elements of the covariance matrix explained the variances of each variable. The variance measures how much the data are scattered about the mean.

Table 1: Output of Covariance Analysis

Correlation Probability	Unemployment_Total	High_Tech_Exports
Unemployment_Total	1.000000	
High_Tech_Exports	-0.345112 (P-Value0.2484)	1.000000

Above the output shows, the results of covariance analysis. In these results, the covariance between high technology exports and unemployment total is approximately -0.345112. This value indicates the relationships is negative between those two variables. And also, the probability value (0.2484) is higher than the alpha value (0.05) in 5 % of significant level. So, we said, there is no significantly evidence to conclude the negative relationship between high technology exports and unemployment total.

#### 4.2. Correlation

Correlation is measuring both the strength and direction of the linear relationship between two variables. In this study, correlation was checked by the graph of Ellipse and Kernel Fit. Figure 4 is the graph of Ellipse and Kernel Fit. It is also helped to identify the relationship direction and strength between the dependent and independent variables. Basically, if the ellipse is elongated and constricted, we can conclude it was showing a strong negative or positive relationship.

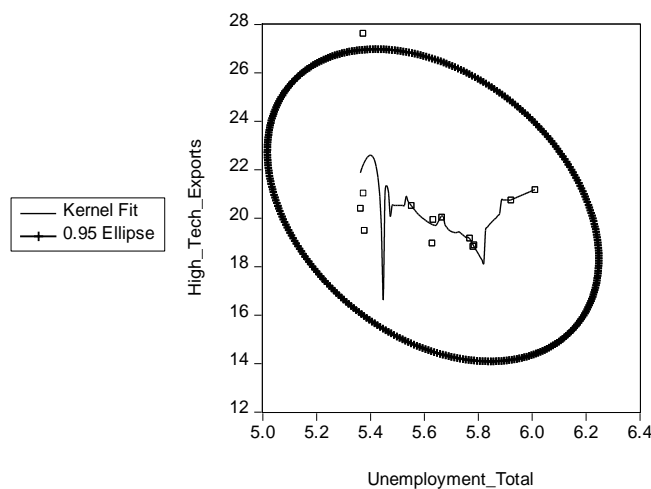

Figure 4: The Graph of Ellipse and Kernel Fit

Above the table, an ellipse is broad and appear negative form. So, the relationship between those two variables is very weak and kernel fit also did not show a strong negative relationship above the graph.

#### 4.3. Cointegration (Long Run)

Cointegration is a technique used to find a probable correlation between time series processes in the long run. Nobel laureates Robert Engle and Clive Granger find the concept of cointegration in 1987. First, we test the stationary which is test being series having trend or seasonal effects. Basically, time series are stationary if they do not have trend or seasonal effects. We check the stationary of high-tech export and unemployment by Augmented Dickey-Fuller unit root test. We have done ADF test those two variables one by one. Which is based on below the null and alternative hypotheses.

$H_0$ : The series has a unit root (Non – Stationary)

$H_1$ : The series has no unit root (Stationary)

Table 2: The Result of ADF Test Unit Root on the Level Form of the Original Series

Form	Model	High tec export (P-value)	Unemployment (P-Value)	Stationary
Level	Intercept and no trend	0.1365	0.3475	No

Table 3: The Result for ADF Test Unit Root on the First Form of the Original Series

Form	Model	High tec export (P-value)	Unemployment (P-Value)	stationary
<b>First Different</b>	Intercept and no trend	0.0033	0.0001	Yes

Basically, when the probability value is less than the significant value, we accept the alternative hypothesis. From the result, we can conclude both series are stationary in the first difference form. Because the p-value is less than the alpha value (0.05) at a 5 % significant level. So, we accept our alternative hypothesis. Next, we test for a unit root in the residual series of the estimated equilibrium relationship by employing the Dickey-Fuller test. Therefore, the null and alternative hypotheses are:

$H_0$ : The residual series has a unit root (No cointegrated)

$H_1$ : The residual series has no unit root (Cointegrated)

The residual unit root test results are shown in table 4. We can conclude residual series are non-stationary or the residual series has a unit root. Because of p-value is higher than the alpha value (0.05) at a 5 % significant level. So, high technology and unemployment total are not cointegrated indicating that there is no long-run equilibrium relationship.

Table 4: ADF Test Result for a Unit Root on Residual

Form	P-value	stationary
<b>Level form</b>	0.1570	Non-Stationary

## 5. CONCLUSIONS

The main purpose of the study is to find the direction, strength and long-term relationship between high technology exports and unemployment total. This paper points out there is no direction between the dependent variable of unemployment and the independent variable of high-tech exports. In the special case, clearly, understood that there is no long run relationship between those two variables. In the future, a change has to be made any other suitable proxy variable for the technology and increase the time period to this analysis, its maybe find new conclusion regarding the relationship. Moreover, this study found World widely high-tech export did not affect unemployment. Therefore, Technological advancement should benefit to the fullest extent. It should not affect social welfare in any way. According to the study, high-tech exports did not cause unemployment. So high technology-based exports may have many beneficial effects. These should be explored in the future.

## REFERENCES

- Aktar, I. and Ozturk, L., 2009. Can unemployment be cured by economic growth and foreign direct investment in Turkey?. *International Research Journal of Finance and Economics*, 27, 203-211.
- CFI., 2015. Cointegration [online]. Corporate Finance Institute. Available from: <https://corporatefinanceinstitute.com/resources/knowledge/other/cointegration/> [Accessed 25 October 2021].
- CFI., 2015. *Unemployment* [online]. Corporate Finance Institute. Available from: <https://corporatefinanceinstitute.com/resources/knowledge/economics/unemployment/> [Accessed 24 September 2021].

- IMF NEWS, 2010. *IMF Survey: Sharp Rise in Unemployment from Global Recession* [online]. International Monetary Fund. Available from: <https://www.imf.org/en/News/Articles/2015/09/28/04/53/sonew090210a> [Accessed 24 September 2021].
- Ismail Aktar, Latif Öztürk, and Nedret Demirc., 2008. *The Impact of Fdi, Export, Economic Growth, Total Fixed Investment on Unemployment in Turkey* [online]. Semantic Scholar. Available from: <https://www.semanticscholar.org/paper/THE-IMPACT-OF-FDI%2C-EXPORT%2C-ECONOMIC-GROWTH%2C-TOTAL-Aktar-%C3%96zt%C3%BCrk/df51e79ee6c7cdf1e2b4ef361c93efc601994e2> [Accessed 24 September 2021].
- Kasemsap, K., 2016. *Implementing Electronic Commerce in Global Marketing* [online]. IGI Global. Available from: <https://www.igi-global.com/chapter/implementing-electronic-commerce-in-global-marketing/148989> [Accessed 24 September 2021].
- Kasemsap, K., 2017. *Trends and Issues with Massive Open Online Courses* [online]. IGI Global. Available from: <https://www.igi-global.com/chapter/trends-and-issues-with-massive-open-online-courses/181384> [Accessed 24 September 2021].
- KhairulAmri, & Nazamuddin. (2018). Is There Causality Relationship between Export and Employment: A Time Series Data Evidence from Indonesia. *International Journal of Academic Research in Economics and Management Sciences*, 7(2), 86–99.
- Ozughalu, U.M. and Ogwumike, F.O., 2013. Can economic growth, foreign direct investment and exports provide the desired panacea to the problem of unemployment in Nigeria?. *Journal of Economics and Sustainable Development*, 4 (1), 36-51.
- Ranjaguru, G. and Gaston, N., 2010. How an Export Boom affects Unemployment. *ISER Seminar Series*, 1-30.
- Sivarajasingham, S. and Mustafa, A.M.M., 2016. *Time Series Data and Usage of E-views*. 1<sup>st</sup> ed. East Thirunelveli: Tamil Nadu.
- Vivarelli, M. 2015. Innovation and employment. *IZA World of Labor 2015*: 154 doi: 10.15185/izawol.154.
- Walden University., 2021. *Social Welfare Policy: Introduction: The Policy Process* [online]. W| University Library. Available from: <https://academicguides.waldenu.edu/library/socialwelfarepolicy> [Accessed 24 September 2021].
- Yılmaz Bayar., 2014. Effects of economic growth, export and foreign direct investment inflows on unemployment in Turkey. *Investment Management and Financial Innovations*, 2(2), 20-27.

# A Review on Outsourcing Strategy and Firm's Superior Performance

K. A. I. M. Amarasekara\*

Division of Management Studies, University College of Matara, Sri Lanka

## ABSTRACT

*In today's expeditious and dynamic business world, organizations are looking for innovative solutions and strategies to enhance their competitive advantage. Outsourcing is one of these strategies that can create more advantages over the other competitors. Outsourcing is the handover of the goods and services production that can be done internally to an external supplier who is identified as an expert in that quality. Therefore, this research mainly intends to study the impact of outsourcing strategy on firm superior performance. In this article, analyze and review the existing academic literature on the implications of outsourcing performance and note that results have yielded mixed results. It is argued that outsourcing has potential effects on a range of "performance" outcomes. Also it is also further argued that many of the empirical studies have inconsistent designs and provide a number of recommendations to guide future empirical work.*

**Keywords:** Competitive Advantage, Firm Performance, Outsourcing.

## 1. INTRODUCTION

Outsourcing has become very popular since a two decades time and has received a significant amount of attention of the practitioners and researchers (Gilly et al, 2004; McIvor, 2009; Evergert et al, 2007, Perunović, 2007, Lahiri, 2015, Ishizaka et al., 2019). Lahiri (2015) mentioned that researchers who have studied outsourcing are mainly focused on why, when and how companies are adopting outsourcing strategy, what are the possible advantages and disadvantages of outsourcing practice, and what factors make up best practice or success and outsourcing. (Barthelemy 2003; Onen & Erickson 2009; Kotabe et al 2008; Maskell et al 2007; Varadarajan 2009).

As per the view of many researchers (Agburu, 2017; Tayauova, 2012) outsourcing concept is considered as one of the most important and effective key strategies, which applied the complex, dynamic and competitive challenges in modern business world. Because many companies intend to use sound management tools and all innovations of science, techniques to achieve their goals and to issue qualified and competitive products and services which will achieve the consumer satisfaction. (Adams et al. 2018 as cited by Ishizaka et al. 2019). Even though outsourcing concept became systematic consideration for many researchers and bearing many positive and negative implications from theoretical perspective, the reality of the application for organizations is controversial (Tayauova, 2012).

Even though outsourcing has considered as a very interesting and smart option, its specific effect on firms' performance has not yet been well revealed by research (Kayumba, 2019). Many researchers (for example, Gilley and Rasheed, 2000 cited by Zahra and Pati, 2018) have found that outsourcing and firm performance relationship has generated mixed and contradictory findings including a positive relationship (Lahiri, 2015), a negative relationship (Rodríguez and Nieto, 2015; Singh, 2009) and no relationship at all (Broedner, Kinkel, and Lay, 2009; Weigelt, 2009). Further they mentioned that many recent studies highlighted that the existence of non-linear relationships between outsourcing and firm performance, yet again producing contradictory findings such as U-shaped (Bhalla, Sodhi, and Son, 2008; Gilley and Rasheed, 2000) and inverted U-shaped relationships (Massini, Perm-Ajchariyawong, and Lewin, 2010). Findings of Taouab and Issor (2019) revealed that firm performance has converted a popular concept and frequently used as popular dependent variable in strategic management research. However, improving firm performance is difficult through only in-house operations. Therefore the outsourcing has been identified as a strategy to acquire the expertise knowledge and unique resources and competencies as well

---

\* Corresponding Authors: Email – [021madushani@gmail.com](mailto:021madushani@gmail.com)

as low-cost advantages of an outside firm to face successfully the challenges in the competitive market (Agburu, Anza and Iyortsuun, 2017).

As mentioned by Lahiri (2015), “Does outsourcing really improve firm performance?” still remains as a problematic concern in the research literature in outsourcing. Having the proper answer to this inquiry is essential, because outsourcing concept is broadly used by firms in most of the industries as a strategic tool by aiming the performance enhancement, especially industries like events industry which needs multitasking capability. Therefore, mainly this research intends to study the impact of outsourcing strategy on firm’s superior performance through systematic review of research articles.

The main objective of this study is to study the effect of outsourcing strategy on achieving the superior firm performance for gaining competitive advantages.

Since outsourcing is widely used phenomenon in globally and abundance of researches are carried out in this area, the findings of this research will help to academics/ researchers for their future researches. Moreover, the findings will also be helpful for the business community who engage directly or indirectly and the study on the analysis of outsourcing on performance is vital because it will help firms engaged in the outsourcing practice to evaluate the impact of outsourcing on their operations.

## **2. LITERATURE REVIEW**

### **2.1. Definition of Outsourcing and Firm Performance**

There are many definitions of outsourcing from different perspectives. According to Kremich et al., 2006, outsourcing denotes to the transfer of non-core activities under a contract. Outsourcing institute has defined outsourcing as the tactical use of outside resources to execute the activities performed by inside employees and resources. This does not mean that outsourced activities are less important. (Kahindi, 2010) Abraham & Taylor, 2006 mentioned that outsourcing can be defined as the use of one company by another company to perform certain tasks. This is because these operations can be performed cheaper or more efficiently. Outsourcing has traditionally been used primarily downsizing and reduce costs in large companies. (Musau, 2016) Outsourcing, which states to the allocation of business activity from an internal source of an organization to an external source, has identified as a main component used in supply chain management strategy (Chase et al., 2004; Lankford and Parsa, 1999).

Firm performance was considered to correspond to organizational effectiveness, which is the degree to which an organization as a social system with having less resources and resources achieves its goals without unnecessary effort on the part of members. The criteria used to measure performance in productivity, flexibility, and inter-organizational tension. (Georgopoulos & Tannenbaum, 1957). As organizations begin to explore new methods of assessing performance, thus performance is defined as the ability of an organization to use its environment to access and use limited resources. (Yuchtman & Seashore, 1967). According to Price (1968) considers performance to be identical with organizational efficiency, and identifies as evaluation criteria: productivity, conformity and institutionalization. (Omar Taouab, 2019) Performance measurement denotes to the practice of measuring the efficiency and effectiveness of a particular action. (Neely, Gregory & Platts, 1995). The measurement of performance, according to Lebas, 1995, is the transfer of the complex reality of performance into organized symbols that can be linked and transmitted under the similar conditions. In today’s business management practice, measuring performance is considered more important than quantification and accounting. (Koufopoulos, Zoumbos & Argyropoulou, 2008). This is consistent with Bititci, Carrie, and McDevitt (1997), who describe performance management as the process by which particular firm manages its performance in accordance with its functional and corporate strategy and objectives. (Al-Matari, 2014)

### **2.2. Outsourcing as an Operational Strategy for any Industry**

Outsourcing has become as the most prominent practice in today’s business world due to high level of competition and dynamic nature in any industry. Over the last few decades, globalization has become



apparent as an inevitable event that continues to change the business environment. Schniederjans (2005) argues that in reality, globalization and outsourcing are the same thing.

### **2.2.1. Reasons for Outsourcing**

There are so many factors lead to choose outsourcing by different companies. According to the literature and according to Neto, 2011, the most quoted factors are: the service provider's expertise; better focus on core business; productivity growth; attainment and bringing up to date of new technologies; lack of internal resources; improved service quality; increase flexible management practice; reduction and control of operating costs; reducing the need for fixed assets; and increased competition (Anderson & Weitz, 1986; Belous, 1989; Greer, Youngblood & Gray, 1999; Gupta & Gupta, 1992; Kakabadse & Kakabadse, 2002; Quinn & Hilmer, 1994; Pires, 20200; Jiang, 20200; Jiang, 1992; Ahlstrom, 2008; Gonzalez, Gasco & Llopis, 2010).

As Prahalad and Hamel pointed out in 1990, the main reason why outsourcing has become an important part of organizational strategy is because companies are beginning to realize that they cannot perform perfectly in all areas, so they decide to make fundamental changes where they conduct business through restructuring activities to stimulate the growth of their core business. Further they mentioned that the main reason for outsourcing is cost saving. (BACEA, 2015)

### **2.3. Firm Performance**

The concept of firm performance and organizational performance originates from the concepts of efficiency and effectiveness. If an organization is performing well, it means that the organization produces the right products and services and uses as few contributions as possible for production. By analyzing company performance and comparing it to company goals and objectives, organizational performance can be measured and it is based on three focal outcomes: financial performance, market performance, and shareholder value performance.

As Buchanan noted in 2014, companies strive to perform well in many areas of the organization. Most significantly, they try to do a good job financially to achieve a good return on investment and excellent profitability. In order to gain as many market shares as possible, companies need to produce the demanded products and offer products at prices they can compete in the market. Finally, they must excel at generating value for shareholders by delivering shareholder return and a sustainable level of growth. (Moses, 2016)

According to Cheng, 2011, research studies on firm performance should comprise multiple performance goals. Such objectives can be generally practicing accounting objectives such as market share, sales growth and profitability. In addition, factors such as consumer satisfaction and non-financial goals for firm owners are also very important when estimating performance, especially in private companies.

### **2.4. Impact of Outsourcing on Firm Performance**

In today's dynamic and competitive business environment every business firm need to think deeply about their products and services, thus they have to more focus on innovations and do things differently or efficiently to keep ahead their competitors and gaining superior firm performance. Therefore strategic decision making is very important and "outsourcing" has been recognized as a strategy among most of the managers which can be used to achieve greater competitiveness by surpassing the rival firms. According to Kremic et al, (2006), there is plenty of literature on outsourcing, where many benefits, risks, motivations and decision factors are presented. Due to outsourcing process has a complex structure that includes many activities and side-by-side activities, many researchers (Gilly et al, 2004; McIvor, 2009; Evergert et al, 2007) identified significant number of theories that could explain the outsourcing phenomenon. As per the findings of Perunović, (2007), stakeholder theory, theory of core competences and the neoclassical economic theory best explain the outsourcing phenomenon which is addressed the concepts of stakeholder management, core competence management and production cost reduction respectively. As per the findings of Gottschalk and Solli-Sæther (2005, 2006), as cited by Perunović, (2007) Transaction cost Economics (TCE) theory and agency theory are also frequently used theories in outsourcing. Perunović

(2007) noted that after a few years of outsourcing, the outsourcer's focus shifted to the resource stage, where the resource-based view (RBV) and core competencies were the most significant descriptive theories against the contract. He also noted that relational views, social exchange and stakeholder theories are also used in some scenarios to explain outsourcing strategy.

Generally most of the organizations intend to implement outsourcing strategy mainly for three reasons. It may be cost reduction and efficiency of the firm, focus on innovation or focus on core competencies. (Musau, 2016) As per the view of Perunovic (2007), TCE has been the most used theory of outsourcing and it professed to provide the best decision making on outsourcing decision and arrangements. However, many researchers argue that as cited by Kamyabi (2011) TCE theory is used to explain employment decisions in areas such as outsourcing accounting (Everaert et al., 2010), audit activities carried out in internally (Carey et al., 2006) and Human Resources (HR) (Gilley et al., 2004). Moreover, as per the view of many researchers (Sahgal & Malhotra, 2005; Kremic et al., 2006; Wang et al., 2008; Sharma & Loh, 2009; Herath & Kishore, 2009, Sparrow, 2005), as cited by Iqbal and Dad, (2013) TCE is focused on cost factors of outsourcing strategies and also according to TCE, services can be outsourced if the strategy carries about cost benefits for the firm. As per the findings of Alaghehband et al (2011), TCE is based on two vital behavioral grounds: bounded rationality and the opportunism of human agents. Also he revealed that there are three significant dimensions of TCE which transactions differ; uncertainty, asset specificity and frequency. In addition, Williamson (1985) stated that asset specificity is the most significant dimension. Two other dimensions also play an important role. According to TCE, the impact of a dimension on a given transaction cost must be assessed for limited and opportunistic reasons. Findings of Alaghehband et al (2011) argued that contradictory results not only in Information Technology (IT) field but also in other domains where TCE has been applied and tested. Carter and Hodgson, 2006 found that as cited by Alaghehband et al (2011), in strategy research, for instance, where TCE has been used to study the firm's boundary decisions, the results show mixed findings, particularly with regards to the role of uncertainty. Another study conducted by David and Han in 2004 reviewed as cited by Alaghehband et al. (2011), the practice of TCE in multiple fields, including marketing, strategy, management science, management, and economics shows that uncertainty produces the most unreliable results. They also found that frequency, alone or in conjunction with entity specificity, was the minimum used construct. Uncertainty is connected with inconsistent results. And entity specificity is the most common construct.

According to the findings of Porter (1985), pioneer academic of strategic management, cited by Asad (2012), RBV recommends that companies should be strategically positioned based on valuable, rare, incomparable and inimitable capabilities and resources, rather than products and services derived from those resources and capabilities. McIvor (2009), indicated that RBV is a model that sees resources as key to superior firm performance. Wernerfelt (1984) suggested that as cited by Neves et al (2013) firms should analyze the diversity of their current and future resources that will affect their competitive advantage. As per the findings of McIvor (2009) RBV specify what functions should be carried out in-house and what should be outsourced and further he mentioned that RBV argues that why firms vary in performance. Also Gilley et al (2004) mentioned that RBV suggests that functions not major to core competencies must be outsourced. As per the findings of Barney and Hesterly (1996) as cited by Vaxevanou (2014) the premise of RBV is that resources and capacities can vary significantly between organizations and these differences remain constant. Also Vaxevanou (2014) mentioned that, when a firm's resources and capabilities are properly mixed and used, it can create a competitive advantage for the company and this theory is mainly applied in the preparatory phase of the process of identifying operations to be outsourced. The limitation of the RBV is competitive advantage can only occur in situations of firm resource heterogeneity and firm resources immobility. (Barney, 1991; Gorver, 1995) Findings of Lockett et al. (2009) revealed The RBV's methodological and practical problem is the problem of repetition. Second, it is assumed (as Barney 2001 did) that RBV can be identified in a testable form. Any experimental assessment of the estimate involves the identification and measurement of the relevant sources. Third, steady diversity poses problems for researchers interested in creating a consistent sample of companies to test a particular RBV hypothesis. And the next step is to identify and explain the causality of the big company in question. Large enterprises are so complex that it is very difficult to isolate the performance impact of a particular resource. The fifth

difficulty is that RBV logic does not predict the universal correlation between corporate performance and specific resources.

McIvor (2009) stated that the concept of core competencies, developed by Hamerand Prahalad (1994), evolved from RBV, has had a significant impact on outsourcing practices, with the distinction between core and non-core jobs firmly entrenched in many practitioner dictionaries. Among most of the available literature, many researchers (Peteraf, 1993; Quinn's, 1992; McIvor, 2000) have discussed that the "theory of core competence" is an important theoretical basis for outsourcing, and provides base and target for outsourcing. Vaxevanou (2014) mentioned that core competence theory is the second most popular method in academic research on outsourcing. The major limitation for explaining outsourcing with the view of core competence theory is the difficulty in the definition of core competence and non-core ability. According to Kahindi (2010), mistakes in identifying core and non-core activities can lead an organization to outsourcing a competitive advantage. But one day at the core may not be the next. It's hard to rebuild. There were tough decisions about how to outsource that, "Close to the core"

As per the findings of Friedman & Giber, 2007, as cited by Iqbal and Dad, (2013) relational view argues that the relationship should consist mutual benefits for both parties of the contract by creating synergy & equal opportunity. Relational theory explains, how organizations gain and maintain competitive advantage by considering relationships with other organizations (McIvor, 2005). Kobayashi (2014) mentioned that in his findings relational theory focuses on building inter-firm competitive advantage and further he identified four prerequisites that create competitive advantage from the viewpoint of relational theory, which Dyer and Singh (1998) suggest. They are located very close to each other specially there are many close investments in private assets and also there is close relationship between proactive knowledge sharing and product features through human interaction The effectiveness of relational theory which promotes investment in special assets and long-standing transactional relationships, depends on product features. There is no guarantee that relational theory will be effective in characterizing products with short-term trading or frequent changes in trading partners. Therefore, the perspective of product properties imposes a limitation on the effectiveness of relational theory.

As per the findings of Perunovic et al, (2006) as cited by Taticchi (2007) the steps outsourcing process are preparation, vendor selection, transition, managing relationship and reconsideration. When considering the main theories of outsourcing, Perunovic (2007) mentioned that TCE is applicable for preparation, vendor selection, managing relationship and reconsideration phases. While core competence theory is applicable for preparation and reconsideration phases, relational view and agency theory are applicable for preparation and managing relationship respectively.

According to Stephan (2002), as cited by Calabrese et al (2005) the base level question whether outsourcing affects positively firms' performance has not been solved. For example, it has been observed that many companies own some activities, previously operated by a third party, because they are dissatisfied with the quality or underestimate the volume of their specific investment in assets. According to Richard et al. (2008), Corporate performance covers three specific areas of a company's results: financial performance (profitability, return on assets), return on investment, etc.); Market performance (sales, market share, etc.); and shareholder returns (total shareholder returns, economic added value, etc.)

But most of the recent findings ( Isaksson, 2015; Kotabe et al, 2009; Kahindi, 2010; Verwaal, 2017) on outsourcing strategy, have discussed only firm financial performance and few studies have carried out on other areas. Moreover, most of the studies (Calia et al, 2017; Arvanitis et al 2011; Gilley et al, 2004; Cicek 2011) have conducted to analyze the impact of outsourcing with respect to one key area, specially they focused on IT related operations and human resources. When considering the industries like Events, they have considered as multitasking industries comparatively with other industries, because they require to cover a range of products and services to fulfill the customers' diverse demands. Even though industries like Events have practiced outsourcing strategy in large scale, few studies have carried out the impact of outsourcing strategy on firm performance in such firms. Also according to McIvor (2009), the issues have to address, is outsourcing appropriate for the organization when matching the capabilities of the organization versus its competitors, impact of activities on competitive advantage and supplier's ability to

provide activities supply market. However, most studies do not focus much on these areas. And they discuss whether the direct impact of the outsourcing strategy has a negative or positive impact on the company.

Lahiri (2015) mentioned that in his findings apparently, managers prefer outsourcing to positively influence company performance. And it depends on how the outsourcing company is planned and operated. Results will vary. And every outsourcing effort cannot be estimated to yield similarly positive results. It depends on the scope of the outsourcing and operations of the company. Further Lahiri (2015) stated that Researchers' biases that can affect company-level findings can play a role, and two areas are very important there. First, study simulations that involve similar scope, context, and level of analysis, data sources, and industry. Second, the interaction between industry and researchers needs to be fostered so that managerial and academic thinking can be integrated from the planning phase of outsourcing.

### 3. CONCLUSION AND RECOMMENDATIONS

By considering the positive benefits of outsourcing, main thing is outsourcing helps firms to save costs by limiting their initial investments in fixed assets such as plants and equipment, Moreover, suppliers specializing in specific outsourcing activities are likely to gain economies of scale, leading to lower production costs, which might in part be transferred to the firms engaged in outsourcing. Outsourcing also reduces firms' need to commit to specific production technologies, because it gives firms greater flexibility to adopt technologies as they become available (Weigelt and Sarkar, 2012). Though outsourcing has a lot of benefits it also has several disadvantages. First, it may lead to a decline in the development of internal resources and capabilities, potentially depressing the innovation capabilities of firms. The decline in resource and capability development does not only affect the current activities of firms, but also limits their future growth opportunities, in general, and the opportunity of expanding into the outsourced operations, in particular. Also, suppliers might gain greater bargaining power vis-à-vis outsourcing firms as the capabilities of such firms to internally conduct outsourced activities decrease relative to their suppliers.

Though many studies have carried out on outsourcing and firm performance, in the future, scholars may also follow up and inquire about focus company operations, the closest competitor in terms of sales growth, profitability, consumer satisfaction and overall performance. Many researchers stated (Farrell 2005; Hat' Onen and Eriksson 2009) that future research should explore is outsourcing really permits to focus on core competencies and increase firms' flexibility to react to market changes.

### REFERENCES

- Agburu, J.I., Anza, N.C. and Iyortsuun, A.S., (2017). Effect of outsourcing strategies on the performance of small and medium scale enterprises (SMEs). *Journal of Global Entrepreneurship Research*, 7(1), pp.1-34.
- Alaghehband, F.K., Rivard, S., Wu, S. and Goyette, S., (2011). An assessment of the use of transaction cost theory in information technology outsourcing. *The Journal of Strategic Information Systems*, 20(2), pp.125-138.
- Calabrese, G. and Erbetta, F., (2005). Outsourcing and firm performance: evidence from Italian automotive suppliers. *International Journal of Automotive Technology and Management*, 5(4), pp.461-479.
- Iqbal, Z. and Dad, A.M., (2013). Outsourcing: A review of trends, winners & losers and future directions. *International Journal of Business and Social Science*, 4(8).
- Ishizaka, A., Bhattacharya, A., Gunasekaran, A. et al. (2019). Outsourcing and offshoring decision making.
- Kahindi, A.K., (2010). *The relationship between outsourcing and firm financial performance in the banking industry in Kenya* (Doctoral dissertation).
- Kamyabi, Y. and Devi, S., (2011). Accounting outsourcing and firm performance in Iranian SMEs. *International Journal of Economics and Finance*, 3(4), pp.181-192.
- Lahiri, S., (2016). Does outsourcing really improve firm performance? Empirical evidence and research agenda. *International Journal of Management Reviews*, 18(4), pp.464-497.
- Lockett, A., O'Shea, R.P. and Wright, M., (2008). The development of the resource-based view: reflections from Birger Wernerfelt 1. *Organization Studies*, 29(8-9), pp.1125-1141.

- McIvor, R., (2008). What is the right outsourcing strategy for your process?. *European management journal*, 26(1), pp.24-34.
- McIvor, R., (2009). How the transaction cost and resource-based theories of the firm inform outsourcing evaluation. *Journal of Operations management*, 27(1), pp.45-63.
- Musau, C.N., (2016). *The impact of strategic outsourcing on organizational performance: A case study of Bidco Africa Limited* (Doctoral dissertation, United States International University-Africa).
- Perunović, Z. and Pedersen, J.L., (2007). Outsourcing process and theories. In *POMS 18th annual conference* (Vol. 10).
- Taouab, O. and Issor, Z., (2019). Firm performance: Definition and measurement models. *European Scientific Journal*, 15(1), pp.93-106.
- Taticchi, P., Christoffersen, M., Lunghi, P. et al. (2007). Collaborative and Non-collaborative Vendor Selection Processes: Three stories from Umbria. POMS 18th Annual Conference < [http://www.poms.org/conferences/poms2007/cdprogram/topics/full\\_length\\_papers\\_files/007](http://www.poms.org/conferences/poms2007/cdprogram/topics/full_length_papers_files/007).
- Vaxevanou, A. and Konstantopoulos, N., (2015). Models referring to outsourcing theory. *Procedia-Social and Behavioral Sciences*, 175, pp.572-578.

# Assessment of Municipal Solid Waste Management System in Colombo Municipal Council

D.C.M. Abeyakoon\* and T. Denagama

Department of Construction Technology, University of Vocational Technology, Sri Lanka

## ABSTRACT

*As the largest municipality and commercial capital of Sri Lanka the Colombo Municipality faces numerous challenges due to high quantity of Municipal Solid Waste (MSW) generated. The purpose of the study is to assess the MSW management systems of the Colombo Municipal Council, its existing problems and develop recommendations to overcome these issues. Interviews, questionnaire surveys, and expert discussions were used to collect both qualitative and quantitative data for the study. SW management system of the Colombo city has incorporated several sustainable practices. To some extent, MSW segregation is carried out successfully in the area. Biodegradables are used for compost. Recyclable waste is recycled and non-degradable waste are sent to a waste-to-energy plant. According to the findings of the study, the most significant problem is less focus on reduction of MSW. In addition, inadequate collection system, illegal dumping and public attitude towards MSW management are issues that need to be addressed. Implementing a sustainable approach by considering an Integrated Solid Waste Management system that is suitable to the Municipality and carrying out public awareness are important to overcome problems. Community contribution and participation is important for an effective MSW management in the Colombo Municipal Council.*

**Keywords:** Colombo Municipal Council, Problems, Sustainable, Solid Waste.

## 1. INTRODUCTION

Due to rapid urbanization and the growth of the population, municipal solid waste generation is increasing at an alarming rate. The main challenge of the Colombo Municipality is to find strategies to manage the municipal solid waste in a sustainable and environmentally friendly way.

The Colombo Municipal Council is the largest municipal council, presiding over the commercial capital in Sri Lanka. It accommodates many residents, commercial establishments, industries, hospitals, education institutions, hotels, public places and many more. It covers approximately 37 km<sup>2</sup> and it is highly urbanized and densely populated. (Colombo Municipal Council, 2015) It is divided into six districts for administrative purposes. The permanent population is estimated to be around 555,000 with an addition of 600,000 daily floating population arriving from all over Sri Lanka for various purposes, (Colombo Municipal Council 2015). The MSW generation within the municipality, is approximately 550 MT per day, which is nearly half of the MSW generation in the Colombo district.

The other significant factor in the municipality is the scarcity of land. Lands suitable for the MSW management process are difficult to find due to high urbanization and increased population. The municipality has had to rely on the other local governments and the central government for assistance in locating appropriate land for land filling and storage facilities. However, residents of other local government areas have expressed their disapproval to the municipality using property from their area for land filling or storing: mostly because the public have lost confidence in the Municipality's ability to handle MSW without causing them or the environment any nuisance.

---

\* Corresponding Author: E-mail - [mabeyakoon@gmail.com](mailto:mabeyakoon@gmail.com)

## 2. AIM AND OBJECTIVES

The aim of the study is to assess the MSW management systems, its existing problems and develop strategies to overcome the MSW management challenges.

The objectives of the research are;

- To study the existing MSW management systems in the Colombo Municipal Council
- To identify the problems of MSW management and develop recommendations to overcome the MSW management problems in the Colombo Municipal Council

## 3. LITERATURE REVIEW

MSW generation is one of the main problems in managing MSW. It is expected that the MSW generation by 2050 will be 3.4 billion tons, to the prevailing 2.01 billion tons today. Out of this, 33% are still not managed in an environmentally safe manner. (What a waste 2.0 2018, p.3). The municipalities have the sole responsibility to manage MSW as specifically stated under the Municipal Council Ordinance (1947). There are many problems arising from MSW due to the increase in generation, says Ahsan et.al (2020). The relevant authorities find it difficult to manage MSW properly. If not properly managed, the entire process, from collection to disposal, will result in serious problems. To overcome the problem, both government and public support are required, and integrated solid waste management supports the local needs. Technology and environmental sustainability are also important when considering the solutions to the problems. Vithana (2016) observes that due to rapid urbanization, has increased MSW generation. To mitigate the problems associated with MSW, it is necessary to implement an Integrated Solid Waste Management system by preventing, minimizing and recycling it. Other than Integrated Solid Waste Management, there are many sustainable approaches to MSW management, such as composting, Bio Gas generation, Animal/Poultry food generation, 3R system and incineration. (Hikkaduwa et. al, 2015)

## 4. METHODOLOGY

### 4.1. Study Area

The study area for the research is the Colombo Municipal Council city limits and shown in figure 1. The municipality is divided into 6 administrative districts, and the study was carried out in one of the districts, which is known as district 2B. Kollupitiya, Slave Island, Maradana, Hunupitiya, Maligawatta and Dematagoda areas belong to the District 2B area.

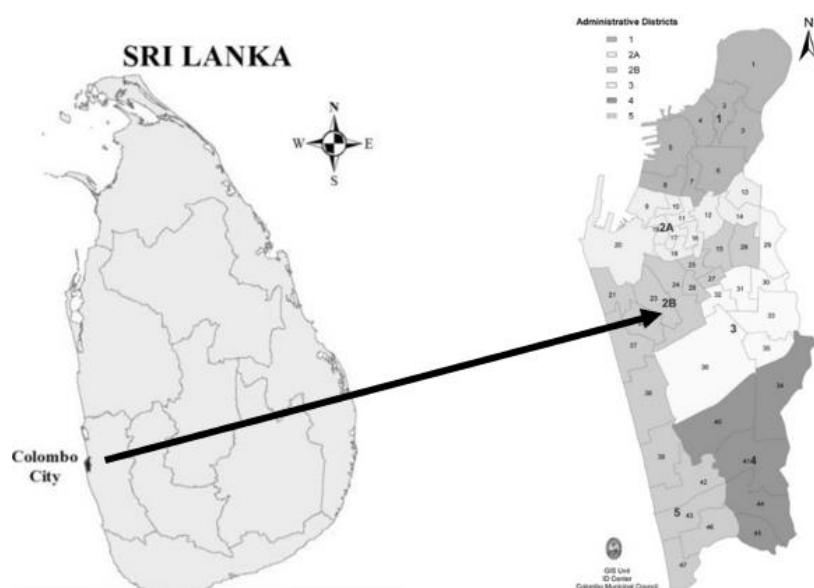

Figure 1 : Colombo Municipality limits

## 4.2. Data Collection

A mix method was used in the study, which required both qualitative and quantitative data. Qualitative data was collected through interviews, discussions, and non-participant observation, while quantitative data was collected through a questionnaire. The interviews were conducted with District Engineers from the Colombo Municipal Council's Solid Waste Management Division to assess the existing Municipal Solid Waste management systems in the Colombo Municipal Council. Discussions with the experts were held in order to provide recommendations on how to solve the existing problems in the MSW management systems of the Municipal Council. Non-participant observation was used to determine the current MSW management systems and their related issues. A questionnaire survey was carried out with 60 members of the municipality staff who are involved in the MSW management systems, the private company's management staff of 60, who are involved in the MSW management systems in the municipality, and randomly selected 60 waste generators from the general public. Secondary data on MSW generation through years and MSW types collected by the municipality was obtained from the Colombo Municipal Council data base.

## 5. RESULTS AND DISCUSSIONS

### 5.1. Existing MSW Management System in Colombo Municipal Council

The Colombo Municipal Council is responsible for managing MSW in the Colombo City. The Municipal Engineers Department's Solid Waste Management Division is in charge of MSW management in its entirety. The overall management is carried out by the Division with the assistance of the private sector. The municipality monitors the private sector-managed areas to ensure that the collection process is carried out smoothly. At present, trade refuse is collected only from commercial places.

MSW is separated into three categories: biodegradables, recyclables and non-recyclables. Segregation of MSW at the source is carried out by the citizens. At present, quarantine waste has been added as another category of MSW. Quarantine waste is not separated but collected as mixed waste.

The collection system of the municipality covers the whole city. The door-to-door collection system, or collection truck system, is carried out in the Municipality as the method of collection. A collection schedule is given to the public by the Municipality indicating the days of collection of different types of MSW.

Biodegradable waste is collected in compactor trucks, while non-recyclable waste is collected in compactor trucks or open trucks. Recyclable waste is collected in a tractor with divided compartments. As the compactor trucks, cannot reach most of the underserved settlements, all categories of MSW are collected in carts and transferred to the compactor trucks or open trucks. The storage is done only for recyclable waste; other waste is transferred straight to the disposal sites.

Furthermore, the study found that as part of existing disposal methods, biodegradables are sent for composting and animal feeding. Non-recyclables are sent to the Waste to Energy plant at Kerawalapitiya. Recyclables are stored at recycling centers and eco kiosk in Colombo city where recycling waste collectors come to collect them. The quarantine waste is also sent to the Waste to Energy plant at Kerawalapitiya.

### 5.2. Waste Generation and Composition

Figure 2 shows that MSW generation in Colombo City is decreased over the years. This is mostly due to start of segregation of waste in the municipality area and shifting the fish market to Peliyagoda, consequently reducing MSW generation in the city to some extent. However, the generation of MSW in Colombo city remains high. According to the figure 3, Colombo Municipality generates more biodegradable waste. This amounts to 48% of kitchen waste and 14% of grass and wood. The other 38% consists of non-degradable waste; out of this, 29% of MSW is recyclables and 9% is non-recyclable.



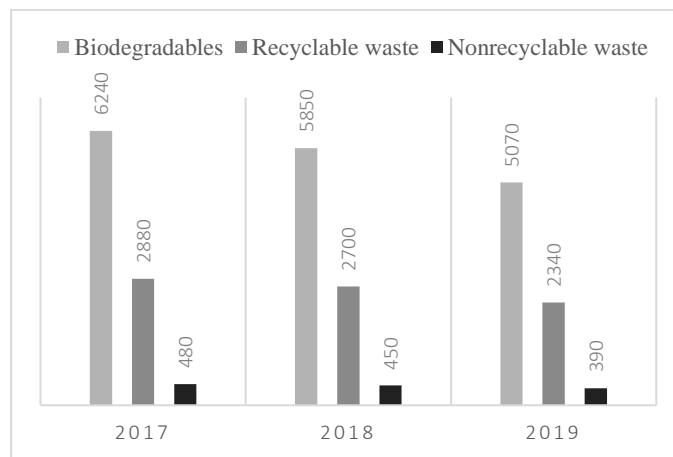

Figure 2: MSW Generation in Colombo Municipal Council (Source: Colombo Municipal Council data base, 2019)

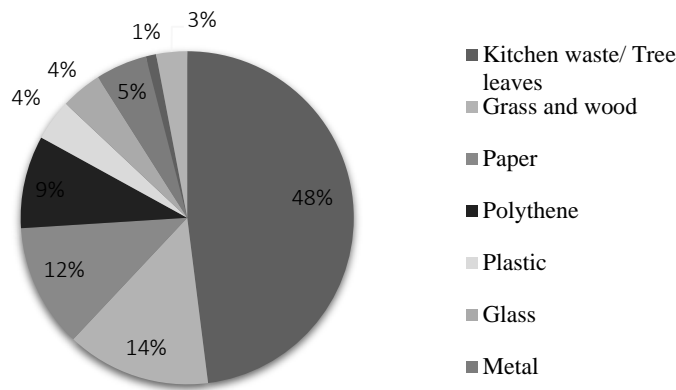

Figure 3: MSW composition in Colombo Municipal Council (Source: Colombo Municipal Council data base, 2019)

### 5.3 The Existing Problems in Msw Management

It was found through the research that there are many associated problems in the MSW management systems in the Colombo Municipal Council. These problems affect the effective and efficient MSW management systems of the municipality. The problems that were found through the questionnaire survey were categorized according to the process of MSW management.

The most significant factor is lack of focus on MSW generation, which consequently increases MSW, especially the nondegradable waste. This is due to excessive packaging and the public buying things that are not needed or will not be uses for their daily activities (over consumption).

Segregation of MSW not being done properly at the source is another problem that requires attention. A prominent problem in transportation is that a suitable location is not available to unload carts and load to trucks. Currently this is done on the side of the road, which create traffic congestion, environmental pollution and littering of the area.

The most significant problem with storage is the unavailability of adequate space for storage at source. As a result, when there is a delay in collection, waste tends to end up on road sides and waterways.

Another significant problem is illegal dumping on road sides and waterways (Figure 4). This will reduce the environmental quality of the area, create mosquito breeding grounds, and increase health problems. Disposal of large equipment such as refrigerators and washing machines, as well as other wastes such as tires, ceramic/porcelain, wind shield glass create problems to the municipality.



Figure 4: Illegal MSW dumping

Other than the above problems, lack of public support has a direct impact on MSW management. Difficulty in implementing any rules and regulations, less labour for MSW services, and lack of short-term and long-term plans are also problems associated with MSW management.

#### 5.4 Recommendation to Overcome the Problems in Msw Management Systems

The research indicates that the most important factor, but least focused, is the reduction of MSW generation. Priority should be given to the reduction of waste, and this can be done by conducting public awareness programmes not only in the municipality area but across the whole island. This can be achieved by involving the public and private sector establishments. The government should be involved in media campaigns that could educate citizens on ways of reducing MSW and its impact on humans and the environment.

The door-to-door collection system should be carried out daily if possible, in all underserved areas where the problem persists the most. It is also important to practice MSW segregation more effectively at the source. This can be carried out by implementing training programmes for the community.

In areas where illegal dumping occurs, 24-hour surveillance should be implemented. Furthermore, a monitoring system in the Colombo Municipality area to ensure the proper MSW management process is carried out is another crucial step. Providing distinct training to the staff, supervisors, and workers in the solid waste management division of the municipality, is also of utmost importance.

As per the National Policy of Sri Lanka, the municipality should encourage the 3R system in the daily activities of its citizens. More awareness programmes should be carried out in the city in a more systematic manner. Education in this regard from childhood is most important in handling the situation. Therefore, more focus should be given to school children. Awareness should be carried out among citizens regarding the economic benefits of recycling at home.

Encouragement and support for the creation of handcrafts and other items from recyclable materials as well as promotion of these items among citizens, is another viable option. In addition, implementing more recycling and E-waste collection centers and expanding the existing recycling centers can be recommended.

Promoting home composting through training and awareness programmes. Non-degradable polythene waste can be used as bitumen in road construction work, find the possibility of using bottom ash from waste to energy plant in construction work without sending it to sanitary land fill, involve private sector establishments in taking back large electrical equipment as a disposal method, and find the possibility of using crushed ceramic and porcelain waste in construction as filling material are some of the strategies that can be adopted by the municipality to overcome the disposal problems. More rules and regulations regarding MSW management should be implemented by the government. In addition, the municipality can change their by-laws according to the present situation.

A sustainable approach is needed to establish effective MSW management in the Colombo Municipal Council. Integrated solid waste management is the best option in this regard by considering the waste management hierarchy. Community contribution and participation in the MSW management process is very important in order to make the sustainable approach a success.

## 6. CONCLUSIONS

MSW management problems are common in a developing nation like Sri Lanka, and they are more significant in Colombo city. Despite many strategies adopted to overcome these problems, the Colombo Municipal Council still finds difficulty in managing the problems. It creates many social as well as environmental problems. Promoting the 3R system covering the entire city is very important. To improve the MSW management system, it is crucial to focus on the existing problems and find solutions to them. If management focused more on reducing MSW, many problems could be solved. Public attitude and inadequate knowledge, increases the problems in managing the MSW every day. Inability to find suitable land for the management process within the city also creates problems, as the municipality must depend on a third party. Focusing on the waste management hierarchy and initiating an Integrated Solid Waste management system will change the existing MSW management to a more sustainable approach. As the Municipality alone is unable to find and implement solutions to the existing problems, the government should play a larger role to assist the Municipality in managing MSW in the city. All stake holders in Colombo City must contribute to the sustainable management of MSW. If not managed properly, MSW will affect the social, economic, and environmental aspects of the city. Hence, adopting and adapting a more sustainable approach to the MSW management system towards a zero-waste policy will change the Colombo Municipality area into a healthier, environmentally sustainable living space.

## REFERENCES

- Ahsan, A., Alamgir, M., El-Sergany, MM., Shams., S, Rowshon., MK & Nik Daud., 2014. Assessment of Municipal Solid Waste Management system in a Developing Country. *Chinese Journal of Engineering*, 2014. Doi: <<http://dx.doi.org/10.1155/2014/561935>>.
- Sadef, Y., Nizami, A.S., Batool, S.A., Chaudary, M.N., Ouda, O.K.M., Asam, Z.U.Z., Habib, K., Rehan, M. and Demirbas, A., 2016. Waste-to-energy and recycling value for developing integrated solid waste management plan in Lahore. *Energy Sources, Part B: Economics, Planning, and Policy*, 11(7), pp.569-579.
- Vitharana, AD., 2016. Solid Waste Management In Hambantota Municipal Council, Sri Lanka: Current Practices, Challenges and Prospects. *International Journal of Scientific & Technology Research*, 6(3), pp. 390-398.
- Colombo Municipal Council 2015, *Colombo Municipal Council*, Colombo, viewed 30 October 2020, <[www.colombo.mc.gov.lk](http://www.colombo.mc.gov.lk)>.
- Hikkaduwa, HN, Gunawardana, KW, Halwatura, RU & Youn, Hyoung Hee 2015, 'Sustainable approaches to the municipal solid waste management in Sri Lanka', *6<sup>th</sup> International Conference on Structural Engineering and Construction management*, December 2015, Kandy.
- Municipal Council Ordinance 1947* (Sri Lanka).
- World Bank 2018, *What a waste 2.0*, World Bank Group, 2020 Washington DC, viewed 30 October 2020, <<https://openknowledge.worldbank.org/handle/10986/30317>>.

# Crowdfunding Large Scale Solar Power Generation Projects

J. K. Kanthi\*

Department of Electrical & Electronics Technology, University of Vocational Technology, Sri Lanka

## ABSTRACT

*Regenerative power sources offer a very cost-effective method for power generation when compared with traditional fossil fuel-based generation methodologies. The cost of implementing solar power generation shows a steep price drop over the past 15 years. However, it is important to use the right implementation strategy to achieve the best results. Ownership of large-scale solar power generation farms is held by a few companies and consumers resort to rooftop solar power generation as the easy alternative to benefit from solar power generation. This gives rise to various power quality-related issues that the utility companies must control and manage. Utility companies do not have a handle to ensure that power connected to the grid is maintained at an acceptable level of quality when many scattered small power generators owned by consumers are connected. This paper discusses the alternative to eliminate entry barriers for large-scale solar power farm implementation with the usage of the modern financing concept -crowdfunding. The Paper also discusses the problems related to rooftop power generation with solar panel-based systems connected to the grid directly in scattered form. The proposed method of crowdfunding to implement large-scale power generation facilities could provide the same or better benefits to households/investors interested in becoming contributors to solar power generation. Thereby, providing economy of scale, that is only achievable through large-scale power generation. Small scale investors or potential rooftop solar power investors can embark on large-scale power generation that offers many advantages over-dispersed rooftop power generation. Crowdfunding helps to eliminate entry barriers for the consumers/investors to own large-scale solar power generation farms. Small scale investors or consumers of electrical energy can benefit from the advantages of large-scale power generation while the utility companies benefit from procuring high-quality power from manageable sources.*

**Keywords:** Crowdfunding, Economy of Scale, Green Energy, Solar Power.

## 1. INTRODUCTION

### 1.1 Background

Many countries including Sri Lanka have encouraged public participation in generating electrical power using solar energy. Most of the countries and utility companies encourage households to partake in green energy generation and have removed legal barriers (Gazette No.2006/19, 2017) to generate and sell electrical power. However, the actual generation seems to be lagging behind the true potential.

Figure 1 details the reduction in the potential. Market potential is further reduced due to constraints relevant to practical implementation problems and getting non-technical consumers/households involved in the power generation process. Though the systems used in solar power generation have low maintenance, it does require certain level of maintenance to ensure that the system performs at its peak during its service life. Installing the system in optimum locations with good solar irradiation, Growth of vegetation, Inverter Failure (Talayero et al, 2018) surface getting covered with bird droppings and debris, Failure in connections and individual modules, Solar cell overheating are some common causes that decrease energy production. Therefore, it is important to keep the systems running in its optimum state to get the best power output of the system – which is a technical task that require specialized knowledge that is lacking in general consumers who are interested in benefiting from power generation in individual capacity.

---

\* Corresponding Author: E-mail - [kanthi.jayaweera@uovt.ac.lk](mailto:kanthi.jayaweera@uovt.ac.lk)

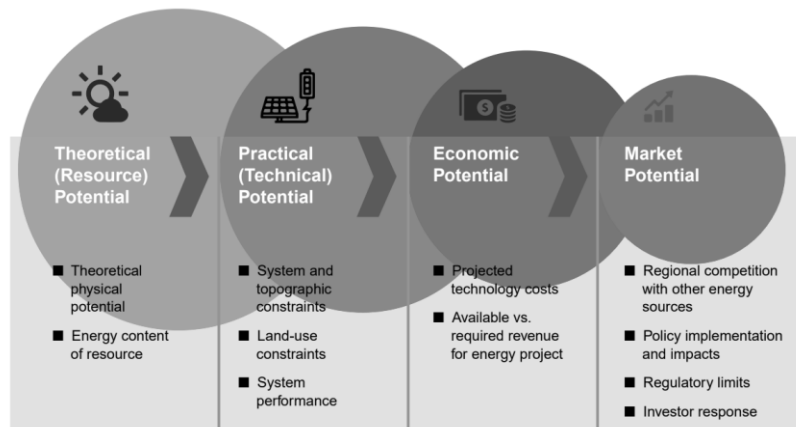

Figure 1: Reduction of the Potential from Theoretical Potential to Market Potential (Brown et al, 2016)

## 1.2 Research Problem

There has been a considerable number of academic and market research activity to maximize the usage of solar power generation. Due to the ease of the implementation and passing the direct benefit to the consumer through billing/buy-back, rooftop solar power generation has seen widespread usage in the recent past. Qualitative, and quantitative research has been conducted to discuss and reveal the concerns related to rooftop solar power generation. This research paper discusses the grid connection related concerns and practical problems related to rooftop solar power generation and propose an alternative method to achieve the same benefit that eliminate or reduce the inherent shortcomings related to highly distributed small scale power generators such as rooftop solar.

The hypothesis is that consumer funded (Crowdfunded) large scale solar power generation plants operating in optimum geographic locations can generate more power and pass the same cost advantage to the consumers.

## 2. IDENTIFYING THE PROBLEM DOMAIN

### 2.1 Uneven Global Distribution of Solar Irradiation

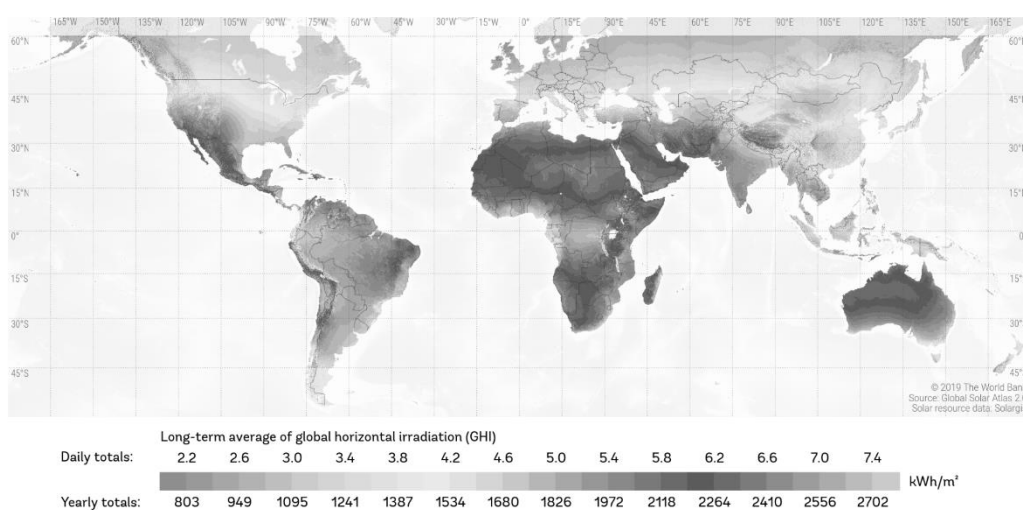

Figure 2: Horizontal Irradiation: Long-Term Yearly Average – World (The World Bank, 2020)

A common problem in getting the individual consumers engaged in power generation by mounting roof top solar power generators is that they live in non-optimal geographic locations for solar power generation.

This is a common problem as solar irradiation is non uniform across geographies. Diagram 2.0 shows the variation of power generation annually vary from 803kWh/ m<sup>2</sup> up to 2702kWh/ m<sup>2</sup> for a unit area (m<sup>2</sup>).

### 2.2 Uneven Distribution of Solar Irradiation in Sri Lanka



Figure 3: Horizontal Irradiation: Long-Term Yearly Average – Sri Lanka (The World Bank, 2020a, 2020b)

Solar Irradiation is not uniform even though Sri Lanka is a country close to the equator. As shown in Figure 2.1 the ability to generate power through solar irradiation vary between 1607-2045 kWh/ m<sup>2</sup>.

Solar Irradiation is merely one factor that needs to be considered when placing a solar power generation system on a roof top. The consumers should be willing and should have the financial capacity to afford such a system. If we consider the per capita income against district as an indicator of the income level of consumers we could clearly see the disparity between the income level and ideal location to place a solar power generation system. Most of the high incomes earning consumers or households are in urban areas. Urban locations pose other challenges like the roofs of single storied houses are covered by other buildings (shadows) and the path of solar travel may not be optimal to generate the maximum amount of power that would otherwise be possible.

### 2.3 Affordability of Rooftop Solar Power Generating System

A primary factor to attract consumers to any product or benefit is the ability of them to afford the product or service. The highest per capita income in the country is distributed among a few provinces which are also urban than the rest of the areas in the country.

If we disregard the willingness of consumers to invest in solar power generation and consider the level of income (DEPARTMENT OF CENSUS AND STATISTICS, 2017), mean household income as the ability for a household to afford solar power generation, Table 1 shows the distribution of income. It is quite evident that the provinces with the highest income are not the locations that have the best solar irradiation (as shown in Figure 3). Therefore people who are able to afford investing in a solar power generation are located in non-optimal geographies with best solar irradiation - in the case of Sri Lanka. Therefore the system does not generate its maximum power output when it is non-optimally placed. Also time period that it takes to recover the investment is longer.

Table 1: Mean and median nominal household income per month by sector and province in Sri Lanka, Year 2016

Sector/Province/District	Mean (Rs.)	95% Confidence Interval (Rs.)		CV%	Median Income (Rs.)
<b>Sri Lanka</b>	<b>62237</b>	<b>60365</b>	<b>64109</b>	<b>1.5</b>	<b>43511</b>
<b>Urban</b>	88692	79590	97793	5.2	57833
<b>Rural</b>	58137	56749	59525	1.2	42133
<b>Western</b>	84231	78359	90103	3.6	57514
<b>Central</b>	53053	50235	55870	2.7	40010
<b>Southern</b>	59375	56531	62218	2.4	43605
<b>Northern</b>	46081	42725	49438	3.7	34500
<b>Eastern</b>	43168	39983	46352	3.8	32621
<b>North-Western</b>	60398	56352	64443	3.4	41977
<b>North-Central</b>	60298	54157	66439	5.2	42092
<b>Uva</b>	51635	47876	55393	3.7	36597
<b>Sabaragamuwa</b>	49057	46240	51873	2.9	37043

Source: Department of Census and Statistics, 2017

### 3. POWER QUALITY RELATED CONCERNS IN ROOFTOP SOLAR POWER GENERATION

There are numerous power quality related issues introduced by scattered placements of rooftop solar power generators. Increased penetration of rooftop solar PV is causing undesirable technical impacts on the distribution networks. Several urban distribution transformers in Sri Lanka are exceeding fifty % of the solar PV over the transformer capacity. Power quality issues such as harmonics, over voltage and DC injection (De Silva et al, 2019) are causing power quality related problems.

A summary of power quality issues caused by roof top solar power generation is given in Table 2.

Table 2: Power quality issues caused by Solar Power Generation

Category	Cause
<b>Flicker</b>	• Variations of the solar PV generation (Eftekharijad et al, 2013)
<b>Slow voltage variations</b>	Power flow variations • Apparent motion of the position of the sun, change in cloud cover, Shading effects
<b>Fast voltage variations</b>	• High capacity solar PV • Tracking systems • Intermittency of the power generation due to change in cloud cover, climatic conditions • Variations in the reactive power (Smith et al, 2017)
<b>Over-voltage</b>	• Solar generation (or any DG) increases voltage at terminals of the generator

<b>Voltage Unbalance</b>	<ul style="list-style-type: none"> <li>• Uneven interconnection of single phase inverters</li> </ul>
<b>Low order harmonics</b>	<ul style="list-style-type: none"> <li>• Harmonic network impedance affected by solar PV inverters [9]</li> <li>• Primary emissions determined by the control algorithm of the inverter</li> <li>• Secondary harmonics caused by the background distortion and the input impedance of the inverter (Smith et al, 2017)</li> </ul>
<b>Supra harmonics</b>	<ul style="list-style-type: none"> <li>• Residues from the switching in inverters</li> <li>• Connection, disconnection of neighbouring sources impact on primary emissions</li> <li>• Neighboring harmonic sources causes secondary emissions (Salas et al, 2006)</li> </ul>
<b>DC offset</b>	<ul style="list-style-type: none"> <li>• Inverters are sources of DC injection (Salas et al, 2006)</li> </ul>

#### 4. BULK POWER GENERATION VS ROOFTOP SOLAR POWER GENERATION

The concerns discussed in section 3 above, proves that rooftop power generation as individual units are non-optimal, causes power quality issues, maximum output depends on the geographic location, may extend the recovery time of the investment and the general consumer/household may not be at a technical capacity to monitor and maintain the power generation system to perform at its peak.

This in no way means that solar power is an unsuitable method for power generation. It is just that solar power generation should be used in its optimal form as a proper bulk power generation means. The implementation of large power generation plants provides economy of scale, placement in optimum locations, ability to recruited qualified staff to maintain the system, implementing proper power quality improvement gear/equipment. When solar power is generated and provided as a bulk supply the utility company has a good control to monitor the quality of the power generated to make sure it meets the quality requirements. The problem of transformers getting overloaded does not happen as dedicated transformers can be provisioned to support the bulk power generator.

#### 5. SOLUTION - CROWDSOURCING BULK POWER GENERATION

Given that individual rooftop solar power generation introduces power quality and other concerns, it appears that bulk power generation using solar farms is a cost-effective method to generate electrical power that gives better handle to control the shortcomings related to power generation in small scale scattered generation topology. Power quality can be monitored and controlled easily before connecting to the grid. The utility companies will have a manageable number of sources who will be accountable for ensuring that quality is maintained to an acceptable level over the entire life cycle of the generating plant. It is practically impossible to hold the non-technical consumers accountable for the quality of power they generate and connect to the grid, owing to the lack of knowledge of general consumers and not having the right measuring gear to monitor/measure power quality. Also, consumers have limited knowledge to maintain the system at its optimum condition to generate the maximum amount of power.

Academic level research has been conducted to numerically estimate the potential impact of crowdfunding in practice based on real data to prove that crowdfunding is a simple but effective way to boost green generation compared with government policies and technology improvement (Zheng et al, 2015). Crowd funding gives the consumers the ability to invest in large scale solar power generation plants and place them in the best geographic locations and keep it under the supervision of experts. The large-scale generation entities can be easily held accountable to the quality of power that they generate. Qualified engineers can be tasked to monitor and maintain the generation facility ensure that it meets the power generation targets envisaged, thereby providing the intended return on investment, and maximizing the usage of the system.



A possible question between benefiting from roof top solar power generation vs. engaging as an investor for a large scale power generation plant, is if crowd funded generation can yield the same benefits to the investor (electricity consumer) that is comparable to benefits of rooftop solar – Table 3.

Table 3: Comparison of benefits between Rooftop Solar Vs Crowd-funded Solar Power Generation Farm.

<b>Benefit</b>	<b>Rooftop Solar Power Generator</b>	<b>Crowd-funded Solar power generator farm</b>
<b>Sell generated Electricity to the utility company</b>	Yes	Yes
<b>Have a zero cost up to a certain amount of electricity units consumed</b>	Yes	Yes (Note: Change in utility company billing system is required)
<b>Generate the maximum energy possible from the Generator</b>	Yes / No	Yes
<b>Ensure Power quality that meets or exceeds utility company guidelines during the service life of generator</b>	No	Yes

## 6. SUMMARY AND CONCLUSION

From the findings of the research it is evident that power quality related problems are introduced by rooftop solar power generators. The problems add up to create difficult to solve problems to the utility company and reduce the quality of the power delivered to general consumers.

From the research findings, it is evident that the method of bulk generation with crowdsourced funding mechanisms provides the benefit of solar power generation without the associated problems with rooftop solar power generation. Therefore the hypothesis was proven to be correct and crowd funded solar power farms provide additional benefits that cannot be achieved otherwise by rooftop solar power generators – therefore it is a better alternative to rooftop solar power generators. Consumers themselves benefit from receiving power quality that is otherwise not possible to achieve when scattered solar power generators are connected to the main power grid. Power distribution utility companies will benefit by not having transformer overloading and low-quality power problems.

It is recommended to generate power using solar farms (bulk generation) over implementing scattered rooftop solar power generators, and funding of such initiatives can be done by electricity consumers through crowdfunding to achieve similar or better results over investing in rooftop solar power generation.

## REFERENCES

- Ana P. Talayero, J. J. Melero, Andrés Llombart, Adrián Casado 2018. International Conference on Renewable Energies and Power Quality (ICRE PQ'18) Salamanca (Spain), 21st to 23rd March, 2018.
- Brown, A., Beiter, P., Heimiller, D., Davidson, C., Denholm, P., Melius, J., Lopez, A., Hetteringer, D., Mulcahy, D., and Porro, G., 2016. Estimating Renewable Energy Economic Potential in the United States: Methodology and Initial Results. NREL Technical Report. Available from: <https://www.nrel.gov/docs/fy15osti/64503.pdf> [Accessed 29 September 2021].
- DEPARTMENT OF CENSUS AND STATISTICS, Ministry of National Policies and Economic Affairs, October 2017. Household Income and Expenditure Survey – 2016, Final Results, (January to December 2016), ISSN-2012-760X
- De Silva H.H.H, Jayamaha D.K.J.S, Lidula Widanagama Arachchige (2019) Power Quality Issues Due to High Penetration of Rooftop Solar PV in Low Voltage Distribution Networks: A Case Study. Conference: IEEE International Conference on Industrial and Information Systems (ICIIS) 2019At: Peradeniya, Sri Lanka.

Eftekharijad S, Vittal V, Heydt G.T, Keel B, Loehr J (2013) Impact of increased penetration of photovoltaic generation on power systems, IEEE Transactions on Power Systems, vol. 28, no. 2, pp. 893 - 901, 2013

Ronghuo Zheng, Ying Xu, Nilanjan Chakraborty, Katia Sycara (2015) A Crowdfunding Model for Green Energy Investment, Twenty-Fourth International Joint Conference on Artificial Intelligence (IJCAI 2015).  
Salas V, Olías E, Alonso M, Chenlo F, Barrado A (2006) DC current injection into the network from PV grid inverters, in Photovoltaic Energy Conversion, 2006.

Smith J, Rönnberg S, Bollen M, Meyer J, Blanco M (2017) Power quality aspects of solar power – results from CIGRE JWG C4/C6.29, International Conference & Exhibition on Electricity Distribution (CIRED), 2017.

Solar resource maps of Sri Lanka, 2020. The World Bank, Source: Global Solar Atlas 2.0, Solar resource data: Solargis.<https://solargis.com/maps-and-gis-data/download/sri-lanka> [Accessed 29 September 2021].

The Gazette of the Democratic Socialist Republic of Sri Lanka, EXTRAORDINARY, - 2017.02.14 No. 2006/19

The World Bank, June 2020. Global Photo Voltaic Power potential by country, Energy Sector Management Assistance Program.

# Factors Influencing Brand Preference of the Cake Industry

Shalika N. Wanniarachchi<sup>\*1</sup>, U. G. Rajapaksha<sup>2</sup>

<sup>1</sup>Department of Management Studies, University of Vocational Technology, Ratmalana, Sri Lanka

<sup>2</sup>Department of Management and Finance, Kotelawala Defence University, Ratmalana, Sri Lanka

## ABSTRACT

*To be a successful organization, they must consider the needs and wants of the customer. Although the alternatives are objectively similar, people are willing to pay for certain brands. Therefore, organizations have to build their brand and develop the preference of customers towards their brands. The main purpose of this research is to examine the effects of customer satisfaction, repurchase intention, service consistency, and product differentiation on brand preference in the context of the cake industry. The relationship between the independent variables and the dependent variable and hypotheses were formed as per the several factors that have been identified through the literature review. The deductive approach is used in the study and the strategy is a survey method as the data collection was done via questionnaires. A sample of 50 customers use to gather data and Statistical Package for Social Sciences (SPSS) 25 version is used as a statistical tool to assess and analyze the data. Finally, the results illustrate that customer satisfaction, product differentiation, service consistency, and repurchase intention factors are positively affected Brand preference in the cake industry. As well as according to the research, service consistency is the most influenced factor when customers choose a cake brand.*

**Keywords:** Brand Preference, Customer Satisfaction, Product Differentiation, Repurchase Intention, Service Consistency.

## 1. INTRODUCTION

Consumer brand preference is a crucial point under consumer selection behavior. The company has to build a competitive advantage to survive in the industry by delivering memorable experiences to the customer. To increase the consumer preference towards some specific brand there are some factors to consider and improve by the companies such as customer satisfaction, product differentiation, service consistency, and repurchase intention.

A successful brand that cannot be copied by competitors, enhancing consumer preference and brand strength about competing brands demonstrates their success, ability to win customer preferences and build long-term relationships (Kay, 2006). If the consumer always keeps the same brand, they need to focus on differentiating their products from their competitors. Happy customers are more likely to show loyalty to the company, such as the desire to deliver positive words, repurchase products, and pay more for products because of trust (Schult, 2005).

## 2. PROBLEM STATEMENT

Today, companies compete in a global market that is struggling to create long-term competitive advantages to ensure their survival. In the industry, when each product is compared to its competitors, consumers begin to face an important problem and the uncertainty about different product qualities is increasing. In these situations, brands can play different roles in the consumer decision-making process. (Romani et al. 2012)

---

\* Corresponding Author: E-mail- [shalikawanniarachchi@gmail.com](mailto:shalikawanniarachchi@gmail.com)

Despite the assumptions of early studies, brand preference is a powerful predictor of consumer motivation and future buying decisions (Bagozzi, 1982; Bass and Talarzyk, 1972). Only a few studies examine the effects of brand preference and its impact on future decisions. Therefore, there is no understanding of how preferences are formed and the consequences of this. (Dhar and Novemsky, 2008; Singh et al, 2005) More specifically, this study aims to investigate the factors affecting brand preferences in the cake industry. This study seeks to investigate specifically, the influence of different factors such as customer satisfaction, product differentiation, service consistency, meeting demand of the products, consumer experience on consumer's brand preferences.

### 3. RESEARCH OBJECTIVE

To increase the market share of a business by developing a strong brand image

### 4. RESEARCH DESIGN

#### i. Conceptual Framework

The conceptual framework as shown below in Figure 1, is the relationship between the independent variable and the dependent variable as per the several factors that have been identified as important to the research objectives through literature review.

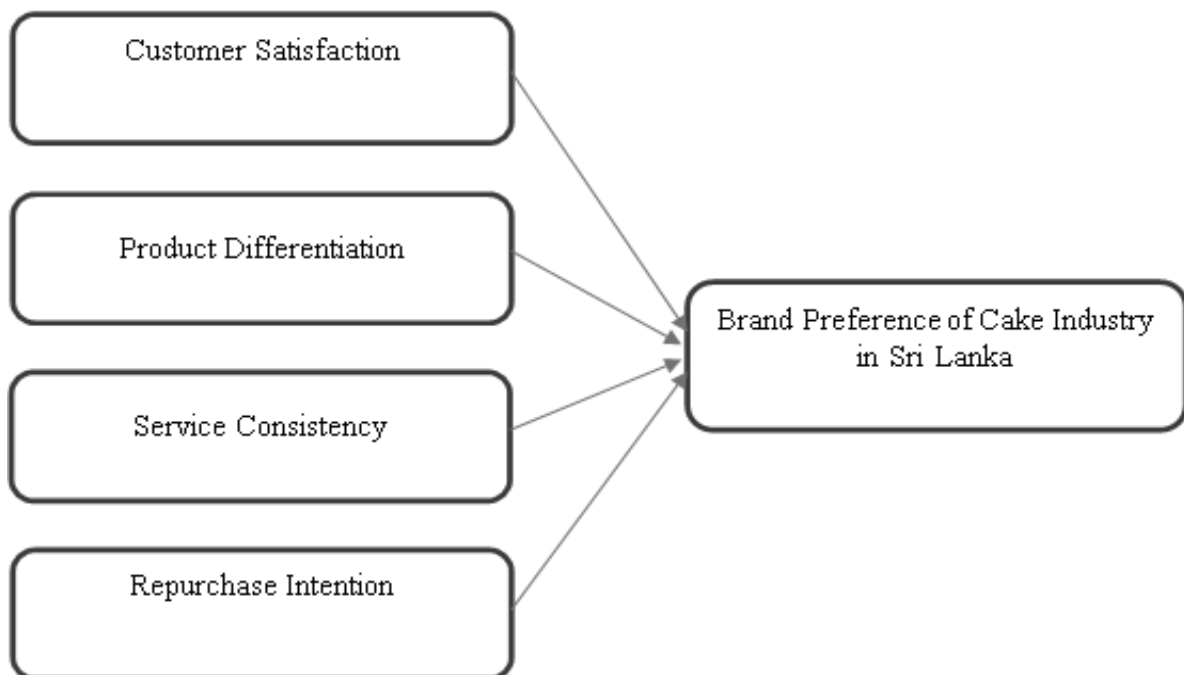

Figure 1: Conceptual Framework - Factors Influencing Brand Preference of the Cake Industry

#### ii. Sampling Profile

As the sampling method, the stratified disproportionate sampling method as a probability sampling technique is used to collect data for the quantitative study. The philosophy of the study is positivism, as its investigations are done scientifically. The deductive approach is used in the study and the strategy is a survey method as the data collection was done via questionnaires.

### iii. Data Collection Method

The quantitative component intends to collect data as a survey technique. The researcher intends to collect the primary data by structured questionnaire method using 10 university students and 10 school attendants and 30 rural and urban cake consumers in the middle age in the Horana area.

### iv. Data Analytical Method

The researcher uses the Statistical Package for Social Sciences (SPSS) 25 version as a statistical tool to assess and analyze the data gathered through questionnaires. The ordinal regression logit model and linear regression models have been planned to apply to the whole research. KMO and Bartlett's Test of Sphericity, Reliability test, Correlation, and Regression Analysis are done under uni-variate, bivariate and multivariate analysis to identify the impacts and associations of the variables in the Quantitative approach.

### v. Sample Adequacy and Reliability

According to the KMO and Bartlett's test, 88.2 % of changes in the population can be identified in the selected sample.

To make sure reliability, a statistical test was done with the aid of SPSS. 92.3 % composite reliability was made sure based on the Cronbach Alpha.

## 5. RESULTS

For the quantitative study, the research intends to distribute 50 questionnaires to the customers who are like to eat cakes.

Table 1: Tests of Between-Subjects Effects

<b>a. R Squared = .631 (Adjusted R Squared = .631)</b>
<b>b. R Squared = .987 (Adjusted R Squared = .987)</b>
<b>c. R Squared = .864 (Adjusted R Squared = .864)</b>
<b>d. R Squared = .971 (Adjusted R Squared = .971)</b>

Hypothesis 1 (H1): There is a positive relationship between customer satisfaction and brand preference of the cake industry in Sri Lanka.

The results illustrate that customer satisfaction is having a 0.000 significance value and 0.971 R squared value. Since customer satisfaction is a positively influencing factor on the brand preference and 97.1% of brand preference happens due to Customer satisfaction.

The Hypothesis (H1) is accepted.

Hypothesis 2 (H2): There is a positive relationship between product differentiation and brand preference of the cake industry in Sri Lanka

The results illustrate that product differentiation is having a 0.000 significance value and 0.864 R squared value. Since product differentiation is a positively influencing factor on the brand preference and 86.4% of brand preference happens due to product differentiation.

The Hypothesis (H2) is accepted.

Hypothesis 3 (H3): There is a positive relationship between service consistency and brand preference of the cake industry in Sri Lanka.

The results illustrate that service consistency is having a 0.000 significance value and 0.987 R squared value. Since service consistency is a positively influencing factor on the brand preference and 98.7% of brand preference happens due to Service consistency.

The Hypothesis (H3) is accepted.

Hypothesis 4 (H4): There is a positive relationship between repurchase intention and brand preference of the cake industry in Sri Lanka.

The results illustrate that repurchase intention is having a 0.000 significance value and 0.631 R squared value. Since repurchase intention is a positively influencing factor on the brand preference and 63.1% of brand preference happens due to Repurchase intention.

The Hypothesis (H4) is accepted.

As expected, customer satisfaction, product differentiation, service consistency, and repurchase intention are positively related to Brand preference.

According to the results of parameter estimates,

When repurchase intention increased by 1 unit, increase brand preference by 1.047 units

When service consistency increased by 1 unit, increase brand preference by 0.642 units

When product differentiation increased by 1 unit, increased brand preference by 0.983 units

When customer satisfaction increased by 1 unit, increase brand preference by 0.823 units

The above variables provide several managerial implications and are important issues in the development and implementation of marketing strategies that focused on building and maintaining market share.

## 6. DISCUSSION

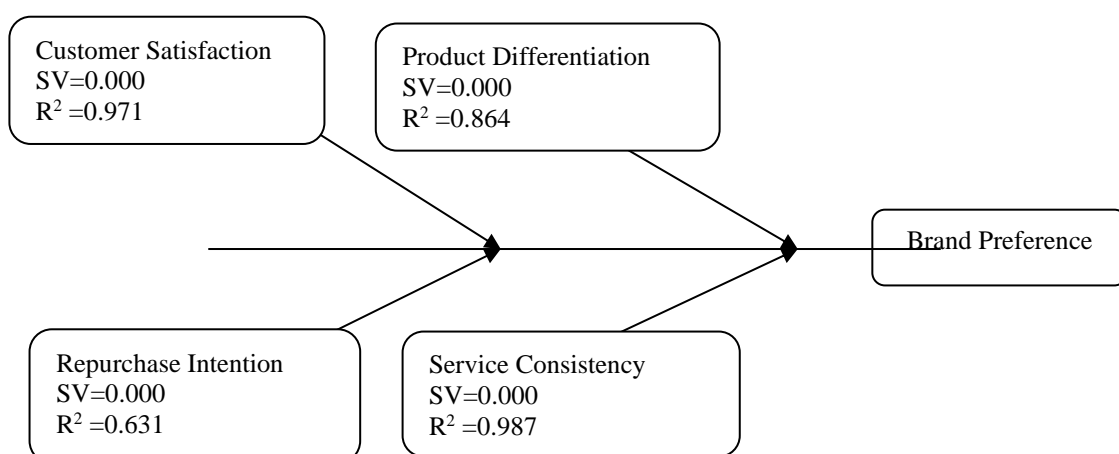

Figure 2: Cause and Effect Diagram of Results

The results suggest that to improve brand preference in the cake industry, marketers should improve the brand strategy that relates to aspects of how the branded cake can provide a solution to their customer's needs and expectations, the good impression of visiting their shop, and the effectiveness of the brand.

However, if consumers are only satisfied with the product, customer service, and price provided by a firm, they may only repeat visiting habitually.

Satisfaction affects brand preference, and dissatisfaction is considered a primary reason why a customer leaves or stops buying a particular brand. (Singh, May 2006) Anton (1996) said that “satisfaction is positively associated with repurchase intentions, the likelihood of recommending a product or service, loyalty, and profitability”. Once customers recommend a brand to another one, it will be happened due to customer satisfaction and always it’s a greater sign of brand preference of the existing customer and acquiring a new customer.

By introducing unique features or characteristics of a product, a company can gain a competitive advantage over other companies that offer similar product substitutes to ensure a unique sales point of the product. Consumers are always preferred to purchase and like to see new products in the market. The likelihood of new experiences is a habit of humans. Because of that to acquire the market position and retain customers with one brand, introducing new products/developing the existing product in a new way is a necessary thing.

Compliance involves the activation and delivery of all features of a service, regardless of time, place, apartment, or provider. Ensuring this consistency with the customer allows the company to build a lasting reputation and develop a competitive advantage. (Petit Robert et.al) When someone visits the outlet or when delivering a product to customers’ doorstep, the service that they expect will satisfy their needs. Satisfying customer needs is an influence on the repurchase intention and if customers are tending to repurchase the same brand it is brand preference.

## 7. CONCLUSION

The goal of every company is to maintain long-term relationships with customers and the business organization. To acquire the potential customers, needs and demands should be acknowledged also brand preference has a great impact on the entire business operations. Therefore, the organization needs to understand what customers want and how to gain loyalty for a successful business. If the existing customers are satisfied with the product and service, then there are opportunities for recommendation to the new ones. As well as, dissatisfied people also give their view about the products, about their unfortunate experience and to bring the number of customers to a declining level.

This will lead to an increasing number of customers and could maintain the level of the relationship with the customers.

This project has gone into depth to understand the correlation between customer satisfactions, product differentiation, and service consistency, repurchase intention, and brand preference. During the research, I figured out the customers are satisfied with the quality of the service, quality of the product and perform the tasks according to the customer’s demand for differentiated products. It can be said, that brand preference is the key component of business profitability because once the customer reaches their preferred level, and it may influence them to consume the service continuously. The research concentrated on the qualitative and quantitative methods to receive valuable information that could be analyzed and verified utilizing scientific research approaches, methods and tools, and theoretical framework.

## 8. RECOMMENDATIONS

However, this study considered just four variables. There may have other important factors, which may influence brand preference in the cake industry. A small sample size of just 50 customers from just one area in Sri Lanka may not represent the vision of all cake customers. Thus, it is recommended that large-scale research with more variables, large sample size with different geographical areas validate these findings.

## REFERENCES

- Abdul Ghafoor Awan, A.-u. R., 2018. Impact of Customer Satisfaction on Brand Loyalty. *British Journal of Marketing Studies*, 2(8), pp. 18-32.
- Abdurrahman ISIK, M. F. Y., 2015. Effects of Brand on Consumer Preferences. *Eurasian Journal of Business and Economics*, pp. 139-150.
- Adinan Bahahudeen Shafiwu, A. M., 2013. The Effect Of Product Differentiation On Profitability In The Petroleum Industry Of Ghana. *European Journal of Business and Innovation Research*, I (4), pp. 49-65.
- Ebrahim, R. S., 2013. *A Study of Brand Preference: An Experiential View*, London: Brunel Business School.
- Hulya GUL1, F. M. K. M. G. M. G. A., 2017. Bakery Products Consumption And Consumers'awareness In Urban Areas Of Isparta City, Turkey. *Scientific Papers Series Management, Economic Engineering in Agriculture and Rural Development*, 17(2).
- McGee, J., 2014. Differentiation Strategies. *Wiley Encyclopedia of Management*, Volume 12, pp. 2-4.
- Neupane, R., 2015. The Effects of Brand Image on Customer Satisfaction and Loyalty Intention in Retail Super Market Chain UK. *International Journal of Social Sciences and Management*, Volume 2(1).
- Singh, H., 2006. The Importance of Customer Satisfaction in Relation to Customer Loyalty and Retention. *Asia Pacific University College of Technology & Innovation Technology Park Malaysia*, pp. 2-5.
- TODOR, R.-D., 2014. The Importance Of Branding And Rebranding For Strategic Marketing. *Economic Sciences*, 7(2).
- Yasri Yasri, P. S. E. H. A. G., 2020. Price perception and price appearance on repurchase intention of Gen Y: do brand experience and brand preference mediates?. [www.cell.com/heliyon](http://www.cell.com/heliyon).
- Zhang, Y., 2015. The Impact of Brand Image on Consumer Behavior. *Open Journal of Business Management*, Issue 3, pp. 58-62.
- N. Paramananda, I. P. G. S., 2018. The Impact Of Price Perception And Brand Image On Customer Satisfaction And Repurchase Intention. *International Journal of Economics, Commerce and Management*, 6(10), pp. 212-218.
- Poranki, K. R., 2015. Brand Preference and Customer Satisfaction of Branded Milk in India. *Research Journal of Social Science and Management*, 5(8).
- Shaian Kiumarsi, J. K. M. I. V., 2014. Marketing strategies to improve the sales of bakery products of the small-medium enterprise (SMEs) in Malaysia. *International Food Research Journal*, pp. 101-107.



# Factors Influencing Cosmetic Buying Behavior of Males: with Special Reference to Galle Area

H. G Dayal Shamin Samarasinghe<sup>1\*</sup>, J.W.P Dilsha Chathurangi<sup>2</sup>

<sup>1</sup>Accounting and Finance Division, University College of Matara, Sri Lanka

<sup>2</sup>H/Kiula Junior College, Kiula, Hungama, Sri Lanka

## ABSTRACT

*To sustain in the cosmetic industry, it is vital to recognize factors that influence consumers buying behaviors. The existing cosmetic industry has a lot of factors that influence consumers buying behaviour. Therefore, the researcher conducted this study under three objectives: to identify factors influencing men's cosmetic buying behaviour with special reference to the Galle area. The conceptual framework was developed based on three independent variables and one dependent variable. The independent variables were Product quality (PRQ), Cost of the product (COP), and Store environment (STE). The dependent variable of the study was men's cosmetic buying behaviour. The researcher collected data by distributing 150 structured questionnaires among selected 150 respondents from the Galle district. The data collection tool consisted of MCQs and five-point Likert scale questions. The statistical package for the Social Sciences (SPSS) software is used for data analysis. Descriptive, Karl Pearson correlation and regression analysis used for data analysis. Further, there are moderately positive associations between the all- autonomous variable and the reliant variable. As indicated by retrospective analysis, PRQ has the most significant impact. Finally, it is suggested that future studies pay attention to a comprehensive study about young males and find out the appropriate ways to reach them. It will be benefited more for each and every people who are producing men's related products.*

**Keywords:** Cosmetics, Cost of product, Product quality, Purchasing decision.

## 1. INTRODUCTION

According to Tiainen (2010), men's cosmetics market increased and men have increased the demand for the cosmetics because of the external environment factors. The general concern for the appearance not just a phenomenon, every period of time it has had its own standers for the physical attractiveness of the people. Since in the 20th century, the cosmetic industry built up with the advertising.

In considering male cosmetic market in the country, it acquired a higher attraction recently. As a unique characteristic of the cosmetic market, it continually attracted many companies to the market. Therefore, not only the local companies try to take advantages from the local market, but also multinational companies desire to reach the market. There is a high competition in the domestic cosmetic market and many companies pay attention to invest in the market for because the continuity of high demand from the market.

On the other hand, now a days, many young men consider outward appearance as something really important, and a part of their personality. With this change, many young men consider about personal grooming, compared to the past. It was not because they need to compete with women who care a lot about their outward appearance, some other factors influence to the men's cosmetic buying behaviour like media, advertising, societal manipulations which leads to change of the traditional thinking pattern. In considering the male cosmetic market, the new market trends extend from grooming products to producing and marketing of those products as well.

---

\* Corresponding Author: E-mail - [hgdsamarasinghe@gmail.com](mailto:hgdsamarasinghe@gmail.com)

In the Sri Lankan context, lack of studies related to men's cosmetic buying behaviour, motivated us to conduct the research to fill the gap. The researchers have identified the situation in the country related to men's cosmetic buying as a new market opportunity.

## **2. LITERATURE REVIEW**

### **2.1. Buying Behaviour**

According to Solomon et al. (2012), consumer buying behaviour refers to the investigation of people or gatherings when they engage in buying, consuming or discarding items, services or thoughts with the purpose of satisfying their wants and needs. Anjana (2018) has explained consumer buying behaviour as a decision-making process and mentality of a person in purchasing and consuming products. After identifying his/her want and needs, the consumer starts to search products or service to fulfil their requirement. Accordingly, today, this process become a complex process and the consumer buying behaviour as a main factor of production or service. Bhatt & Sankhla (2017) have defined customer purchasing conduct as the amount of purchaser's mentalities, interests, purposes and conclusions related to the consumer's behaviour in the commercial centre in buying a particular product or service.

Further, Schiffman et al. 2008, consumer behaviour does not limit to make a choice to buy but link to all practices connected with utilization. Gogoi (2013), as cited by Anjana (2018) has expressed that during the purchasing system, customers are influenced by some external factors and inner inspirations.

### **2.2. Cosmetic Products**

Britannica (2011) has stated that cosmetic products denotes to some of few arrangements (not including soap) which are consumed to the skin for embellishing, maintaining, or changing the appearance or for purifying, shading, moulding, or take care of the skin, hair, nails, lips, eyes, or teeth. According to Draelos & Thaman (2006) have stated that Caring of skin is mainly significant in a diversity of practices such as in facing to sunlight, in new-borns and in recovering infection. Cosmetic products provide looking after and handling of the hygienic term of the skin under the best situations of sanitation and ease for or applying to someone or something without any medical issues. Encyclopedia of Body Image and Human Appearance (2012) has been defined cosmetics as a part of personal decoration with clothing, hairstyle and other ways of body decoration namely tattooing, scarification and piercing.

Anjana (2018) has explained cosmetic products can be made with natural ingredients or chemical ingredients to improve both fragrance and appearance of human body. Accordingly, people pay considerable attention on self- personality and self- consciousness since the interest for cosmetic products is speedily growing.

### **2.3. Product Quality (Prq)**

Garvin (1984) has depicted product quality as the item-based methodology where quality depends on the presence or nonappearance of a specific property. Further Garvin (1984) has stated that according to Leffler's (1982) definition, since quality shows the number of desirable attributes that a product includes, quality can only be received at higher cost and since characteristics are supposed to be expensive to produce, quality products will be more costly.

Several scholars have found that that there is a critical effect of quality on consumer Buying Behaviour (Zeeshan, 2013; Chi et al., 2008; Tsiotsou, 2005 & 2006; Jalivand et al., 2011). Poranki (2015) has found that clients like best quality item on any cost. Jawahar & Tamizhhyothi (2013) have found that individuals are more cognizant with regards to quality. Desai (2014) has found that 85% of people preferred quality with variety at reasonable price of product in Kolhapur. Hossain & Shila (2020) have found that quality and attributes of the item is more imperative to consumers than cost of the product. Eze, Tan & Yeo (2012) have found that Product quality has the greatest effect on consumers' buying behaviour.

Anute, Deshmukh & Khandagale (2015) have found that majority of people consider quality as the most significant factor to buy cosmetic product and wrapping as the least significant factor for purchasing cosmetic product. Bhatt & Sankhla (2017) have found that quality is the super persuading element to favour one cosmetic brand over another product. Further, they have found that there is a connection among cost and Quality of cosmetic products and people has believed that branded cosmetics have the best quality. Chen et al. (2015) have found that quality of skin care product influences to buy aim of purchasers. Further, Rekha & Gokila (2015) have stated that majority of consumers prefer to be brand loyal and quality specific regarding herbal cosmetic products. Desai (2014) has emphasized that quality is the most significant feature for buying of cosmetics by the respondents than price. Khandagale (2015) has identified that quality of product can be reflected as the main factor for buyer's purchase decision regarding cosmetic products and Shajahan & Safi (2019) have also proven this fact through their study.

Yati (2018), cited by Arifin & Qastharin (2019) has stated that men choose cosmetic products with high quality and reachable. Vibhuti, Kumar & Pandey (2014), cited by Bhatt & Sankhla (2017) have found that one of the elements of 4 Ps in marketing which is product quality influences the consumer buying behaviour under Cosmetic products across several psychological and physiological factors. Kumar, John & Senith (2014) have found that quality of a product can influence consumer buying behaviours related to cosmetic products. Priyangal & Krishnaveni (2016), cited by Anjana (2018) have stated that superior grade cosmetics assist to improve and continue the self-confidence of consumers and convenience them to purchase products. Before purchasing a product, people firstly concern about the quality.

#### **2.4. Cost of Product (COP)**

Kotler & Armstrong (2010) have explained price as the cash which is utilized to trade in terms of product or service by a consumer for a value which is received from it. Several scholars have identified that price plays an important role in consumer buying behaviour (Levy & Weitz, 2012; Wickliffe & Pysarchik, 2001; Hermann et al., 2007; Lee et al., 2010; Khraim, 2011).

Desai (2014) has emphasized that people do not pay considerable attention on price when they purchase cosmetic products. Sivagami (2016) has found that price reduction and attractive promotional programs can attract more customers of cosmetic products. Hossain & Shila (2020) have found that people do not pay their considerable attention on price of cosmetic products. Desai (2014) has found only 3% of people have considered price of cosmetic products in Bangladesh according to his study. Yati (2018) has seen as that there is no critical connection among price and buying behaviours towards natural cosmetic products in Indonesia. Further, Scales (2017), cited by Arifin & Qastharin (2019) has stated that men pay less attention on price of cosmetic products compared to women. Arifin & Qastharin (2019) have identified that price does not have significant effect on purchase intention on male grooming products. Vibhuti, Kumar & Pandey (2014), cited by Bhatt & Sankhla (2017) have found that one of the elements of 4 Ps in marketing which is price has an influence on the consumer buying behaviours under Cosmetic products across several psychological and physiological factors.

Kumar, John & Senith (2014) have found that price of a product can influence consumer buying behaviours related to cosmetic products. Bhatt & Sankhla (2017) have found that there is a connection between price and Quality of cosmetic products.

#### **2.5. Store Environment (Ste)**

Kollat and Willett (1967) have defined Store environment as an effort to plan the environment of the store to create positive sensitive and inspiring influences in the buyer's attention with the purpose of ultimately increasing buying chances. According to Mehrabian & Russell (1974), Environment of the store can affect client's passionate responses, i.e. poise, delight and stimulation. Further, they have clarified that the person characteristics of an individual can influence their reaction to the physical encompassing of the store. Chang, Eckman & Yan (2011) have stated that the store's physical environment can induce passionate, physiological and cognitive responses which will influence a person's prevention or method behaviours in a trade store.

Goldsmith and Goldsmith, (2002) have stated that the tangible items and the background of a store can be used to attract the customer for a product. Eroglu & Machleit (1990) have further explained that Store environment consists of tangible and non- tangible components of a trade outlet and these components can be planned in order to affect customer behaviour. By the viewpoint of Faber and Christensom (1995), the touchable features of a store environment include tools, colour pattern, store purity, store arrangement, product presentation and attractive inside design. On the other hand, Donovan et al. (1994) have found that the intangible features include scent, temperature, lighting and music. Further, they have stated that Store environment encourages the consumer's sensitive condition and it seems as a basic intention since which persons stay in a specific store for a long time and spend a higher amount than primarily planned (Donovan et al., 1994). Likewise, basic features of the store will probably develop the desire of clients and will get the clients' consideration accordingly (Peck & Wiggins, 2006).

### 3. OBJECTIVES OF THE STUDY

- To identify the factors affecting to the cosmetic buying behavior of Sri Lankan men.
- To investigate the relationship between factors and men's cosmetic buying behavior with special reference to Galle area.
- To identify the most influencing factors on buying behavior of men's cosmetic buying behavior with special reference to Galle area.

### 4. METHODOLOGY

The main purpose of this research is to recognize the factors that affect to men's cosmetic buying behaviours. To this research, both qualitative and quantitative have used. Therefore, this study has been followed triangulation research method. Deductive approach was applied to this research because this approach supports to confirm and reject the all hypothesis, based on the previous research and theories.

The population of this study is men who use cosmetic products in their day-to day life in Sri Lanka. In this research, the researcher has used a structured questionnaire to collect primary data from the sample of 150 males live in the Galle district southern province, Sri Lanka. Using Krejcie & Morgan, the sample size has been selected and simple random sampling method has been used as the sampling method of this study. Before conduct the main survey, researcher has carried out a pilot survey among randomly selected 30 males in Galle district who use cosmetic products. For data analysis, multiple linear regression model has been used as the main data analysis technique and in addition, Cronbach's Alpha for assessing reliability, KMO and Bartlett's test for assessing validity, Skewness and Kurtosis for assessing Normality, Correlation analysis, ANOVA table have also been used in this study.

### 5. RESULTS

According to results of reliability analysis of this study, the Cronbach's Alpha value is 0.933. When its values of considered variables are greater than 0.60, it reflects that questionnaire is reliable for the study. The procedures generated Kaiser–Meyer–Olkin (KMO Test) value for each construct which was above 0.6 with a significant Bartlett's test of sphericity value, demonstrating that the data was adequate to proceed for the factor analysis. Correlation analysis of this study is presented as following;

Table 1: Correlation between PRQ and cosmetic buying behaviour of men

	PRQ	Buying Behaviour
PRQ	Pearson Correlation	1
	Sig. (2-tailed)	.582**
		.000

	N	150	150
Buying Behaviour	Pearson Correlation	.582**	1
	Sig. (2-tailed)	.000	
	N	150	150
**. Correlation is significant at the 0.01 level (2-tailed).			

As indicated in Table 1, the correlation value between PRQ and men's cosmetic buying behaviour is 0.582 and the p-value is 0.000. Accordingly, the outcomes confirm that there is a moderate positive association between PRQ and men's cosmetic buying behaviour.

Table 2: Correlation Between COP and men's cosmetic buying behaviour

		COP	Buying Behaviour
COP	Pearson Correlation	1	.523**
	Sig. (2-tailed)		.000
	N	150	150
Buying Behaviour	Pearson Correlation	.523**	1
	Sig. (2-tailed)	.000	
	N	150	150
**. Correlation is significant at the 0.01 level (2-tailed).			

Table 2 indicates that the correlation value is 0.523 between COP and men's cosmetic buying behaviour. This confirms that there is a moderate positive association between the two variables.

Table 3: Correlation between STE and cosmetic buying behaviour of males

		STE	Buying Behavior
STE	Pearson Correlation	1	.503**
	Sig. (2-tailed)		.000
	N	150	150
Buying Behaviour	Pearson Correlation	.503**	1
	Sig. (2-tailed)	.000	
	N	150	150
**. Correlation is significant at the 0.01 level (2-tailed).			

According to Table 3, the correlation value is 0.503. According to the outcomes of the correlation analysis, it is evident that STE has a moderately positive association with the men's cosmetic buying behaviour. Skewness statistics of all dependent and independent variables are within the  $-0.5 < \text{Skewness} < +0.5$  range. That means the data is approximately normally distributed. The kurtosis statistics of those variables are close to 3. Therefore, the data set of this study is normally distributed.

Table 4: Model Summary

Model	R	R Square	Adjusted R Square	Std. Error of the Estimate
1	.653 <sup>a</sup>	.427	.415	.26176
a. Predictors: (Constant), PRQ, STE, COP				

The "R square value or Coefficient of determination" highlights that which extent the men's cosmetic buying behaviour (dependent variables) can explain by the PRQ, COP, STE (independent variables). According to above results, R Square for the model is 0.427. It indicates that 42.70% of men's cosmetic buying behaviour is explained by the PRQ, COP and STE. And also, the adjusted R square is 0.415 and it means that 41.5% of men's cosmetic buying behaviour is actually explained by the PRQ, COP and STE.

Further, Analysis of variability table (ANOVA) is indicated to ensure the total significance of the selected model as follows;

Table 5: Analysis of Variance

		ANOVA <sup>a</sup>				
Model		Sum of Squares	df	Mean Square	F	Sig.
1	Regression	7.448	3	2.483	36.237	.000 <sup>b</sup>
	Residual	10.003	146	.069		
	Total	17.452	149			
a. Dependent Variable: BUY_Behavi						
b. Predictors: (Constant), PRQ, STE, COP						

The value of Sig. (p-value) is less than 0.05 in the ANOVA table and indicates that the relationship between independent variables and dependent variable is statistically significant. This model interprets the effect of PRQ, COP and STE on the men's cosmetic buying behaviour. After adopting a multiple linear regression model, following results are generated.

Table 6: Coefficients

Model		Unstandardized Coefficients		Standardized Coefficients	T	Sig.
		B	Std. Error	Beta		
1	(Constant)	1.465	.329		4.447	.000
	PRQ	.287	.095	.168	1.854	.016
	COP	.235	.077	.260	3.058	.003
	STE	.177	.073	.329	3.931	.000

a. Dependent Variable: BUY Behaviour

When it comes to PRQ, for every unit increase in the PRQ, the men's cosmetic buying behaviour will increase by 0.287 and the p-value for the PRQ is  $0.000 > 0.05$ . Considering COP, for every unit increase in the COP, the men's cosmetic buying behaviour will increase by 0.235 and the p-value for the PRQ is  $0.000 > 0.05$ . And also, for every unit increase in the STE, the men's cosmetic buying behaviour will increase by 0.177 and the p-value for the STE is  $0.000 > 0.05$ . Then, researcher can conclude that PRQ, COP and STE are positively affected on men's consumer buying behaviour and the most influencing factor among three variables is PRQ, by referring the related beta coefficients in the above table.

## 6. DISCUSSION

The main objective of this study is to identify the factors that influence men's buying behaviour of cosmetics with three specific objectives. This research has recognized that product quality (PRQ), Cost of product (COP) and Store environment (STE) effect on men's cosmetic buying behaviour. Moreover, the researcher identified that there are moderate positive relationships among three independent variables and the dependent variable (Jawahar & Tamizhjothi, 2013; Sivagami, 2016; Mohan, Sivakumaran & Sharma 2013). Further, the researcher identified product quality as the most influencing factor for the men's cosmetic buying behavior. Concerning the outcomes, the cosmetic companies will help this information to focus on market segments and improve products.

## 7. CONCLUSION AND RECOMMENDATION

Researcher has found very important findings related to the main objective of the study. Consequently, based on these key findings, research has given several implications for marketing and advertising

cosmetic products in Sri Lanka. Quality of the product appears to be the first component that men worry when he has to buy cosmetic, in improving a cosmetic product, the seller must initially choose a quality level that will backing the product's locating in the aimed market. Now, product quality stands for the capability of a product to accomplish its purposes; it comprises the product's overall stability, dependability, precision, user friendly, and other respected characteristics. However, cost of the product also shows as a vital role for the reason that persons who has additional money have more chances to purchase these kinds of products more than people who haven't more money. The store environment was critical to developing positive purchase decision, it make available important indications and influences in the purchase process. For example; store environment can pass the message to consumer regarding quality and valuable information, while forming needs and wants. The vital issue for marketers is in determining which components or combination of components can be affected positively in terms of the ultimate decision of purchase. Based on the analysis, researcher has concluded that product quality (PRQ), Cost of product (COP) and Store environment (STE) effects on men's cosmetic buying behaviour. Therefore, this study suggests some further scopes a comprehensive study about the young male and find out the appropriate ways to reach them. It will more and more benefited for the each and every person who are producing men's related products. In addition, comprehensive study about the current male market in other countries, and it provides useful information for everyone to do the analysis of the competitors and choice the most suitable strategy for the each and every country.

## REFERENCES

- Anjana, S.S. (2018) 'A study on factors influencing cosmetic buying behavior of consumers', *International Journal of Pure and Applied Mathematics*, 118(09), pp. 453–459.
- Anute, N, Deshmukh, A, and Khandagale, A (2015) 'Consumer Buying Behavior towards Cosmetic products', *International Journal in Management and Social Science*, 03(07).
- Arifin, K and Qastharin, R (2019) 'Factors affecting purchase intention towards male grooming product', *Icmem*, 7(9).
- Bhatt, K. and Sankhla, Peena (2017) 'A study on Consumer Buying Behavior towards Cosmetic Products', *International Journal of Engineering Technology Science and Research*, 04(12).
- Chang, H.J, Eckman, M, and Yan, R.N (2011) 'Application of the Stimulus-Organism- Response Model to the Retail Environment: The Role of Hedonic Motivation in Impulse Buying Behavior', *The International Review of Retail, Distribution and Consumer Research*, 21(03), pp. 233–249.
- Chen H *et al.* (2015) 'Consumer purchase intention for skin-care products'. Available at: <http://www.semanticscholar.org/paper>
- Desai, K (2014) 'A study on consumer buying behaviour of cosmetic products in Kolhapu', *Reviews of Literature*, 1(10), pp. 2347–2723.
- Donovan, R. J *et al.* (1994) 'Store environment and Buying Behavior', *Journal of Retailing*, 70(03), pp. 283–294.
- Draelos, Z.K. and Thaman, L.A. (eds) (2006) *Cosmetic formulation of skin care products*. New York: Taylor & Francis (Cosmetic science and technology, 30).
- Eroglu, S.A. and Machleit, K.A. (1990) 'An empirical study of retail crowding: antecedents and consequences', *Journal of Retailing*, p. 201.
- Eze, U.c, Tan C.B, and Yeo A.L.Y (2012) 'Purchasing Cosmetic Products: A Preliminary Perspective of Gen-Y', *Contemporary Management Research*, 08(01), pp. 51–60.
- Faber and Christensom (1995) 'Can You Buy Happiness? A Comparison of the Antecedent and Concurrent Moods Associated with the Shopping of compulsive and non-compulsive buyers', *American Marketing Association*, 6, pp. 378–385.
- Garvin, D (1984) 'What does product quality really mean', *Sloan Management Review*, 26, pp. 25–45.
- Goldsmith, R.E. and Goldsmith, E.B. (2002) 'Buying apparel over the Internet', *Journal of Product & Brand Management*, 11(2), pp. 89–102. doi:10.1108/10610420210423464.
- Hossain, M.S. and Shila, N.S. (2020) 'Factors influencing consumer decision making for personal care products', *Dhaka University Journal of Biological Sciences*, 29(1), pp. 53–59. doi:10.3329/dujbs.v29i1.46532.
- Jawahar, J.V and Tamizhjyothi, K (2013) 'Consumer attitude towards cosmetic products', *International Journal of Engineering and Management Research*, 03(06), pp. 2249–2585.

- Kollat, D.T. and Willett, R.P. (1967) 'Customer Impulse Purchasing Behavior', *Journal of Marketing Research*, 4(1), pp. 21–31. doi:10.1177/002224376700400102.
- Kumar, H. A, John, F. S, and Senith, S (2014) 'A study on Factors Influencing Consumer Buying Behavior in Cosmetic Products', *International journal of Scientific and Research Publication*, 4(9).
- Mehrabian, A. and Russell, J.A. (1974) *An approach to environmental psychology*. Cambridge: M.I.T. Press.
- Peck, J. and Wiggins, J. (2006) 'It Just Feels Good: Customers' Affective Response to Touch and Its Influence on Persuasion', *Journal of Marketing*, 70(4), pp. 56–69. doi:10.1509/jmkg.70.4.056.
- Poranki, K.R (2015) 'Consumer attitudes and perception on personal care products and cosmetics at Visakhapatnam', *India. Research Journal of Social Science & Management*, 05, pp. 220–225.
- Rekha, M. and Gokila, K. (2015) 'A study on consumer awareness, attitude and preference towards herbal cosmetic products with special reference to Coimbatore city', *International Journal of Interdisciplinary and multidisciplinary Studies*, 2(04), pp. 96–100.
- Schiffman, L.G., Hansen, H. and Kanuk, L.L. (2008) *Consumer behaviour: a European outlook*. Harlow, England ; Upper Saddle River, N.J: Prentice Hall/Financial Times.
- Shajahan, M and Safi, M.S (2019) 'A study of consumer behavior towards cosmetic products in Tiruchirappalli district', *IJRAR*, 6(1).
- Solomon, M.R. (2012) *Consumer behavior*. 10th ed. Boston: Prentice Hall.
- The Editors of Encyclopaedia (2011) 'cosmetic', *Encyclopedia Britannica*. Available at: <http://www.britannica.com/EBchecked/topic/139194/cosmetic>
- Tiainen, P (2010) *Marketing male cosmetics, a review of lumen for men products success to date and ideas for improvement*. University of Lincoln.



# Perceptions of Household Level Micro Scale Waste Disposal Methodologies among Apartment Dwellers in Sri Lanka

S.R.M.P. Seneviratne<sup>\*1</sup>, K.G.N.P Rajapaksha<sup>2</sup>

<sup>1</sup>Department of Quantity Surveying, University of Vocational Technology, Sri Lanka,

<sup>2</sup>Asian Institute of Technology, Thailand

## ABSTRACT

*The most common method identified for disposing of Municipal Solid Waste (MSW) in Sri Lanka is the Open Dumping of waste dumped to unplanned non-sanitary yards, which became a national-level problem in the prevalent context. A solution for MSW disposal in certain countries uses alternative methods such as larger-scale engineering sanitary landfilling methods as well as micro-level planning methodologies. Since in the Sri Lankan context, there is a lack of introducing of micro-level MSW planning methods the main idea of this research is to identify the attitudes towards alternative Micro-planning level instrumental methodologies of converting bio-degradable MSW to soil-nutrient rich organic fertilizer compounds. The attitudes at a selected sample of households at apartment dwellers of Sri Lanka has been identified in the research. The study followed through an awareness program to get the feedback perception about introducing of the composting methods to minimize the Biodegradable Solid Waste at its generating point or at micro-level. The results show a significant increase in awareness about how unplanned MSW disposal method harmfulness to the environment. There is also identified a considerable willingness of applying Micro planning level instrumental methodologies between the apartment dwellers to dispose of biodegradable MSW at its ground base.*

**Keywords:** Composting, Composting Methods, Municipal Solid waste, Sanitary Land Filing.

## 1. INTRODUCTION

Municipal Solid Waste Management (MSW) incongruities were identified not only causing environmental hazards and Social problems, but also as causing economic loss for a country. (Asian Development of Technology, 2004).

An Average Sri Lankan citizen noted as generating about 0.62 kg of solid waste per day. (Visvanathan & Trankler, 2003). The Total MSW collected by local authorities of Sri Lanka is around 2900 tons/day, and of 09 provinces of the country around 60% or 1663 tones is collected by Western Province in Sri Lanka. (Premachandra H.S, 2006). As per the Waste Management Authority and the Central Environmental Authority, only half of the waste generated in Sri Lanka is collected among all waste generated. (Hemachandra D., 2019). For most urbanized areas Legal responsibility of MSW management is with 311 Local Authorities for disposing the collected Solid waste. (Premachandra H.S, 2006).

In Sri Lankan context the lesser application of sanitary engineered methodologies for MSW disposal caused with ‘open dumping’ disposal methods, which imposed practices of disposal of MSW with less or no treatment. This is the practice operated by most of the Local Authorities for disposing of MSW at dumping sites (Bandara J.G.J.N, 2008), except a few sanitary projects for compost and biogas production. (Premachandra H.S., 2006). Large scale compost yard projects such as Allawwa, Pannala, Kaduwella, Balangoda locations of the country are functioning for producing compost from MSW (<https://www.unescap.org>), yet the percentage of production over the total daily collected disposal is very less. (Premachandra H.S., 2006).

Under the Environmental Pollution Control Division of Central Environmental Authority 04 project implementation units are identified under the ‘Pilisaru’ Waste Management Project for engineered sanitary Waste Disposal. Accordingly, MSW project at Dompe, Sri Lanka as the only model identified

---

\* Corresponding author: E mail - [srmpseneviratnaunivotec@gmail.com](mailto:srmpseneviratnaunivotec@gmail.com)

as an engineered sanitary Landfill disposal site in the country among the around 349 open dumping disposal sites. (Fernando N. 2020).

With these no obligatory enactment status for National Policy plan level for an engineered sanitary MSW disposal model, the open dumping yard land filling methods practise mostly for MWS disposal in the country (Bandara J.G.J.N, 2008), causing hazardous environmental impacts in larger scale.

Alternatives to minimize the MSW collected at large scale at the domestic micro generation points is needed to identify in this context, since there is a problem for lack of effectiveness of disposing MSW in sanitary modes as sustainable claiming. At the same time since lack of effectiveness of disposing MSW in sanitary modes it is also need to encourage substitute mode of MWS Management strategies to reduce MSW in quantity wise.

This Research is aimed to evaluate the practices of alternative model to dispose the MSW at the generating point, as a way of solving the problems of collecting large scale MSW, and also would act as a substitute method of MSW disposal. This method of treating MSW proposed at micro scale at the collection point is also proposed to be a remedial method for larger scale unplanned open dumping land filling disposal practices.

## **2. LITERATURE REVIEW**

### **2.1. Solid Waste Collected as per Composition**

According to a study conducted to find the composition of MSW stream in Sri Lanka (Bandara J.G.J.N., 2011), composition involves higher amount of biodegradable material, specifically the long term biodegradables and short term biodegradables by data of 09 selected cities in year 2002. As per Central Environmental Authority National Solid Waste Management Program in Sri Lanka the Biodegradable content of the total collected waste is presented in a higher as 62% in percentage.

### **2.2. Methods of Solid Waste Management**

#### **2.2.1. Open Dumping Yard Dumping**

The disposal strategy as MSW land filling applied without any prior engineered treatment to at sites at open dumping strategy is applied, even though there must have been a strategic planned mode prior to the land utilization. (Jayakody et al. 2018)

#### **2.2.2. Sanitary Landfilling for Municipal Solid Waste (MSW)**

Includes a specially engineered treated strata and layers on ground, rather than dumping the waste to bare ground. (Mishara G.). It also includes a Leachate collection system and Methane collection system and ground condition monitoring systems used to avoid hazardous soil contamination and environment pollution. A thick plastic (normally 2-4 feet thick) with a layer of impervious clay is buried in piles.

Bottom of the landfill is lined by a networked plumbing system, a Synthetic linear Earth covers to collect liquids or Leachate, as a fluid released from disposed waste in its decomposing procedure, to prevent material and Leachate from spreading to surrounding ground waterways.

#### **2.2.3. Composting Techniques**

Reutilization of putrescible municipal solid wastes (MSW) in agriculture can provide valuable plant nutrients. (Shah, G.M et al., 2019) Types of Composting and Understanding the Process are identified as Onsite Composting, Vermi-composting, Aerated (Turned) Windrow Composting, Aerated Static Pile Composting.

In-Vessel Composting (Environmental Protection Agency, 2016). This method of waste management composting can be adopted for small scale urban locations such as apartments or flats, small scale houses located in ground and office premises of cities.

### 3. PROBLEM STATEMENT

Large scale land filling with Municipal Solid waste at non-engineered sanitary yards generates major environmental problems such as leachate liquid and also bad smell released to the environment. On the other hand, the releasing of methane gas to the environment with these non-engineered sanitary yards influence the Greenhouse effect in a significant amount by massive garbage mounds at open dumping sites. Hence, in flats or apartments dwellers of urban areas are facing the problems of delaying the MSW collection with unpleasant environmental problems.

Accordingly, in this regard sustainable alternatives on Waste Management to reduce the amount of MSW at the waste generating point/micro planning level are highly acknowledged.

Thus, application of composting technique of transforming the bio-degradable waste in to soil-nutrient rich organic fertilizer at the miniature domestic micro-level, as opposed to larger scale collected MSW garbage strategy is proposed and subjected in this study.

The study is following by a survey to identify the attitudes to recognise possibilities of minimalizing larger scale MSW releasing to the environment by introducing the composting techniques to degrade the MSW at the miniature domestic micro-level.

### 4. RESEARCH OBJECTIVES

Therefore, to achieve the aims of the research the objectives of the study are considered as follows.

1. To identify the perception among the public about the unplanned MSW Biodegradable Solid Waste Disposal and the magnitude of damage done to the environment.
2. To identify the perception of micro-scale composting Techniques of apartment house holders of Sri Lanka to minimize Biodegradable Solid Waste at the generating point

### 5. METHODOLOGY

Therefore, as per the need of promoting MSW minimizing techniques at its generating point, this study proposes to find out the possibilities and potentials of applying a micro level composting technique realistic for Biodegradable Solid Waste Disposal.

Prior to the evaluation of the attitude about the selected case study composting methods, an awareness program about the sample composting methods was conducted and the method was descriptively described in length in the awareness program to individuals.

The study is based on finding out the perception and awareness among house holders of selected apartments of Sri Lanka as follows;

Table 1. Location of Housing Apartments for the sample

The study continues to finding out the perception about composting techniques to minimize house hold

#	Location of Housing Apartment block	Number of house units for sample
1	Wellawatta	10
2	Rukmalgama	10
3	Ratmalana Soyza Flats	10
4	Raddologama	10
5	Mattegoda	10
6	Dematagoda	10

biodegradable MSW at the generating point of micro-scale. Study utilizes the questionnaire method followed after the awareness program about the composting methods. The questioner focused on finding out the public perception at possible environmental hazard occurred by MSW release to the environment as well as the perception of applying composting techniques.

The study sample questioner was distributed among selected as 60 house hold units of the apartment units and 40 collected answered questioners were investigated to identify the perception regarding the application of composting techniques.

**6. RESULTS**

As per the results shown in Figure 1, all the respondents (100%) commented as the waste disposal to be done in a proper manner

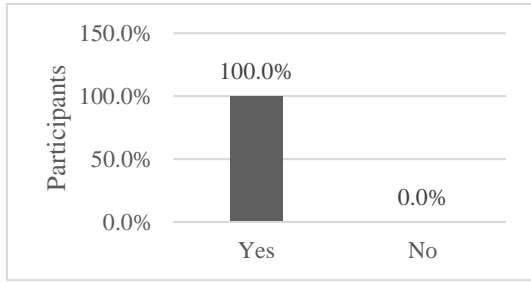

Figure 1: Waste disposal should be done in a proper manner

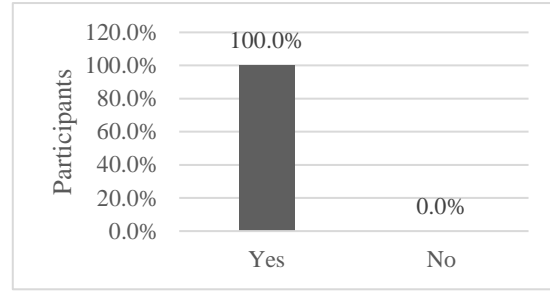

Figure 2: The participants are aware that MSW harms the environment

As shown in Figure 2, all the respondents showed their awareness of the harm caused by the Municipal Solid Waste (MSW). commented as the waste disposed to be done in a proper manner.

As per the methodology applied to dispose the waste from household, among the participants of the study 85.2% of the participants mentioned that they hand over to garbage transportation system, 14.8% of them use a composting technique. The responses are shown in Figure 3.

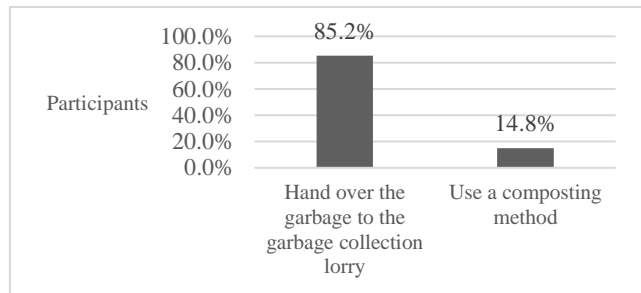

Figure 3: MSW disposing methodology

Further, after the awareness program about the composting techniques 62.5% of the respondents mentioned that they can apply the mentioned system and 37.5% of them mentioned that they needed more knowledge on solid waste management.

As shown in Figure 4, opinions of 32.5% of the respondents were in the view that managing MSW is the responsibility of the central government but 60.5% of the respondents were in the opinion that it should be done within the individual households whereas 7.5% of the participants have responded that it should be done by the private sector.

Figure 5 shows the willingness of the participants to apply the composting methods in the house-holds. As shown in Figure 5, from the total of 40 respondents 71.4% of respondents commented that they like to apply any of the composting methods to degrade the bio-degradable methods. 25.7% of the participants commented they face problems in applying the any composting methods. 2.9% of the respondents do not like to apply the methods to the house hold environment.

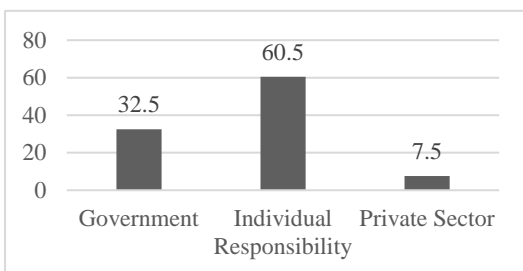

Figure 4: Responsibility of MSW Collection

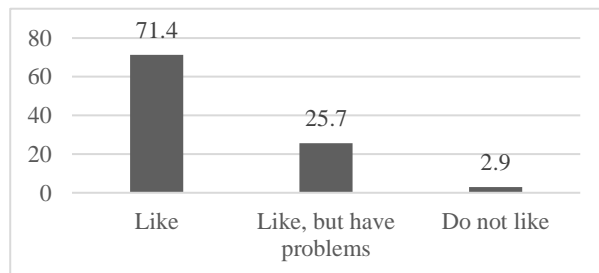

Figure 5: Willingness to apply composting methods at house-holds

When considering the attitudes related to ability of the participants to do waste management at the house-hold level, among the 40 respondents, 70% of the respondents commented as composting methods can be applied in house-hold level, while 30% responded that cannot implement the composting method at households.

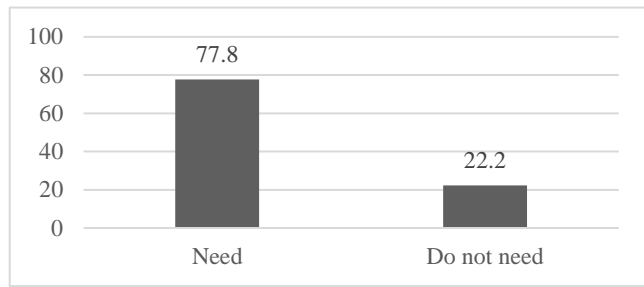

Figure 6: Knowledge in using composting techniques

The reasons for application may be explained with attitudes and opinions among the respondents regarding the application of the method. As shown in Figure 6, 32.5% of the respondents responded that they do not know how to use the composting techniques, and 67.5% of the respondents have mentioned that they know how to use the composting techniques at the house-hold level.

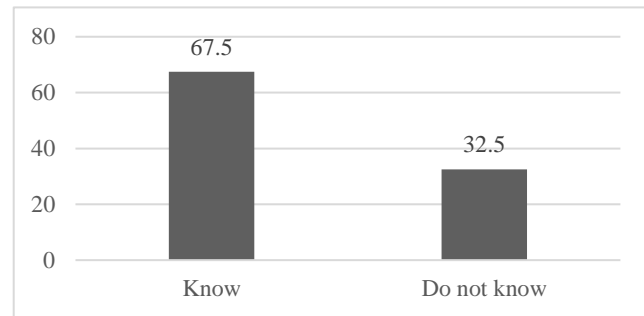

Figure 7: Need of making compost at the house hold level

Further, among the respondents, 27.8% of the responds found it difficult to make the bin while 72.2% responded as it is not difficult for them to make the bin.

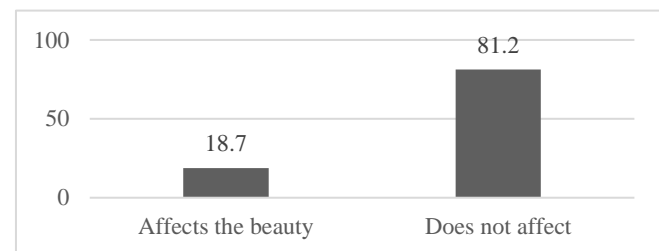

Figure 8: Keeping a compost bin affects the scenic beauty of the household environment

As shown in Figure 7, 22.2% of the respondents commented that they do not need to make compost at the house hold level, whereas 77.8% responded that they have the need of managing the waste to compost in the house-hold.

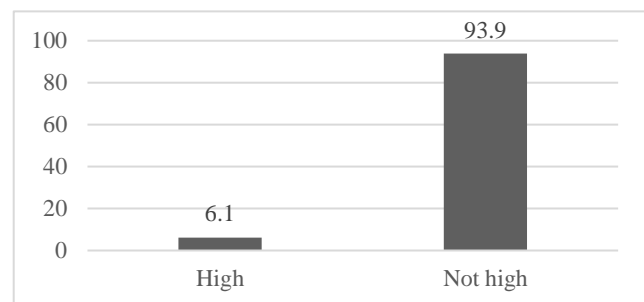

Figure 9: Utilization of fertilizer compost by plant media in the system

For attitudes about locating the bin, 25% of the participants responded that they do not have a place to locate the compost bin in the house hold, while 75% responded as there would be space found.

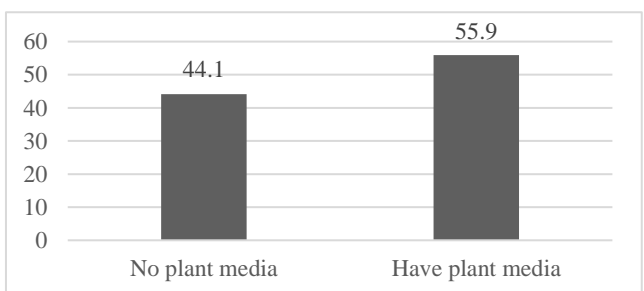

Figure 10: Participants opinions about the maintenance cost

Considering of effect of scenic beauty of keeping a compost bin in the household, as shown in Figure 8, 18.7% of the participants responded that keeping a bin affects the beauty of the surrounding of the household premises, but 81.2% of them have responded that it is not a problem for them. It is shown in Figure 8.

Figure 9 shows the availability of plant media to utilize compost. The respondents who are utilizing compost, 44.1% stated that they have no plant media to utilize composting, and 55.9% of them mentioned that they can utilize the compost as a growth medium.

In considering the opinions of maintenance cost for the composting system, 6.1% of respondents were in the opinion that the usage of the composting method may have high maintenance cost, while 93.9% thought the

cost would not be high. The data is presented in Figure 10.

Figure 11 shows the respondents opinion regarding the discharge of unpleasant smell in keeping composting bin within the house-hold premises. Thus, 57.1% of the respondents were in the opinion that the composting methods may discharge a bad smell as 42.9% responded as there would not be a bad smell from the bin.

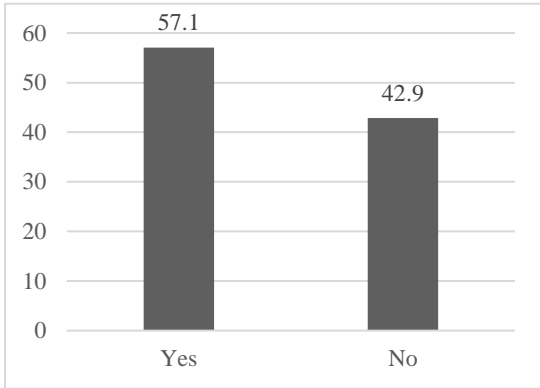

Figure 11: Unpleasant smell might emit from the composting bin

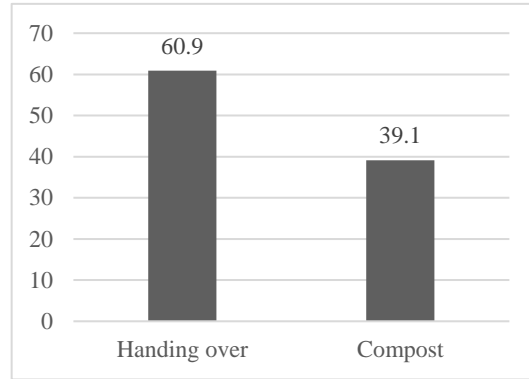

Figure 12: Handing over MSW or composting

Apart from the smell, 55.6% respondents were in the opinion that there would be harmful creatures when a composting bin is stationed in the household but 44.4% of the respondents were on the opinion that such problem will not occur.

As shown in Figure 12, 60.9% of respondents have mentioned that it is easier to hand over the garbage to the garbage collection vehicle, than composting the garbage in the house hold whereas 39.1% responded they would like to compost the garbage in the house hold.

## 7. CONCLUSIONS

The results clearly show the awareness of the general public of apartments of household, about the harmful effect occurred by uncontrolled MSW disposal and open dumping of waste towards disposal sites. All the participants commented that the waste was disposed to be done in a proper manner.

As per the methodology applied to dispose of the waste from households, a most participants responded that they are handing over garbage to the garbage transportation system and less percentage of participants responded as they are using a composting technique. Regarding the awareness program 67.5% mentioned that they can apply explained system and with the awareness program, and 32.5% mentioned that they needed to add more knowledge. A 32.5% of percentage mentioned collect MSW should be managed by the government. A 71.4% totally agreed to apply any of the composting methods to degrade the bio-degradable, as 25.4% mentioned as they have problems in implementing the compost system in their households.

77.8% of the respondents agreed for making compost at the household level, 22.2% did not like the idea. In attitudes about locating the bin most of the respondents responded that they have a proper place to locate the compost bin in the garden or household. Over the effect of the scenic beauty to locate the bin in the premises, most of the participants mentioned that is not a problem for them. 55.9% of the participants stated that they have a plant media to utilize the compost fertilizer. Regarding the cost of the project, 93.9% mentioned as usage of the method has a low maintenance cost.

A 57.1% responded that the system may discharge a bad smell. Regarding harmful creatures developed around the household, 55.6% responded that there would be harmful creatures developed around when a compost bin is kept within the household premises. 60.9% responded that it is easier to hand over the garbage to a disposing system than composting, and 39.1% responded that they rely on composting systems. In analysing the overall opinion, the results show a considerable increase of awareness and

willingness about the application of household-level micro-scale waste disposal methodologies among the studied apartment dwellers in the Sri Lankan context.

## REFERENCES

- Antillón J.J, Amador C.A, Romero R.G, (2018) Food Waste Recovery with Takakura Portable Compost Boxes in Offices and Working Places, *Environmental Protection Research Centre*.
- Bandara J.G.J.N (2011) Municipal Solid Waste Management the Sri Lankan Case, *Conference on Developments in Forestry and Environment Management in Sri Lanka*.
- Environmental Protection Agency, 2016 United States sustainable-management- viewed at 23 May 2021 food/types-composting-and-understanding-process, <, <https://www.epa.gov>,>
- Fernando N, (2020) challenges of municipal solid waste management: learning from post crisis governance initiatives in South Asia, *Project working paper Sri Lanka Doi: 10.13140/org*.
- Hemachandra D, (2019) Solid Waste: Policies and Public Influence in Sri Lanka.
- Premachandra H.S, Oct , Nov 2006, Household Waste Composting & MSW Recycling in Sri Lanka , Central Environmental Authority Sri Lanka , Asia 3R Conference Tokyo
- Qrenawi L., Environmental and Health Risk Assessment of Al-Akaider Landfill, May 2006, University College of Applied Sciences, Research Gate
- Shah,G.M et al., 2019, Composting of municipal solid waste by different methods improved the growth of vegetables and reduced the health risks of cadmium and lead, *Environmental Science and Pollution Research* volume 26, pages5463–5474
- Visvanathan, C. & Trankler, J., 2003. *Municipal Solid Waste Management in Asia-A Comparative Analysis*. s.l., s.n., pp. 3-15.

## **INNOVATIVE CONSTRUCTION TECHNOLOGIES**



# Applicability of Modular Construction Innovation in Residential Buildings in Sri Lanka

D.Dharmendra\*, S. Thusyanthan

Department of Quantity Surveying, University of Vocational Technology, Sri Lanka

## ABSTRACT

*In Sri Lanka, the building sector has experienced an increase in demand for houses over the previous decade, as well as broader concerns about the need to improve performance. The annual housing demand is expected to be 100,000 units in Sri Lanka. However, the current housing supply in the year 2019 is 12,000 units. Several studies have been conducted to analyze the limits and investigate the current method used in Sri Lanka. Nevertheless, house builders are hesitant to embrace this innovation in order to fulfil the present demand for new houses. This research was conducted to explore the applicability of modular building in Sri Lanka compared to the current method of construction. Mixed method approach was used in this research. Selected data collection methods were interviews, questionnaires and document reviews. The findings indicated that compared to current method used in Sri Lanka, modular construction will provide speedy recovery investments, reduce traffic movement, improve health and safety, provide better coordination in management level, control dangerous substances at factories, provide wide range of design, ensure long term job security for labourers, minimise overall life cycle cost, improve energy efficiency, lessen re-work, improve quality of products, lessen site accommodation, provide varieties of design, improve indoor quality, reduce pollution on site, reduce the wastage factor, provide a sustainability approach and reduce accidents on site. Therefore, this research concludes that modular construction will be the trend of house construction in the future. In this aim, traditional builders must be educated about the potential benefits of modular construction through increased awareness and training opportunities in the field.*

**Keywords:** *Modular Construction, New Technology, Off-site Prefabrication, Traditional Construction.*

## 1. INTRODUCTION

According to the central bank report (2020), the government aims to build 100,000 house units annually. However, compared to the year of 2019 the supply of housing units has not achieved the targeted annual rate. Off-site prefabrication methods appear to be primarily motivated by speed of construction rather than anticipated cost reductions as compared to the method of traditional construction (Agha et al. 2021). The utilization of prefabricated units, manufactured off-site and delivered to the intended location for assembly, is the foundation of modular building (Ferdous et al. 2019). These methods used for a variety of purposes such as residential buildings, schools and hospitals (Innella, Arashpour and Bai, 2019). Meanwhile, the traditional building methods dominate the business, particularly in the residential housing sector (Weerasinghe, Ramachandra and Rotimi, 2017).

Sir Michael Latham (1994) stated that the industry's performance might be improved via collaboration among all the stakeholders and the use of new construction building materials, such as off-site manufacturing, to reduce construction costs. Off-site construction method was developed in the United Kingdom (Kyjaková, Mandičák and Mesároš, 2014). However, many markets such as European countries, China, Australia, USA, and Singapore have the conditions in place for modular construction to take root (Bertram, et al. 2019). In Sri Lanka off-site construction methods had been taken place in several places such as Tsunami kit houses in 2005 at Thelwatta by Rukmalgama housing scheme (De Silva, 2017). Furthermore, National Engineering Research and Development (NERD) and National Housing Development Authority (NHDA) have introduced single storey prefabricated models at Ekala and Maligawatta.

---

\* Corresponding Author: E-mail - [devdharma93@gmail.com](mailto:devdharma93@gmail.com)

These market conditions are driven by different dynamics, where owners place a premium on convenience, cost and schedule certainty, and energy savings. According to the findings of (Sharma et al. 2017), it can be classified into followings:

- Component and subassembly
- Non-volumetric pre-assembly
- Volumetric pre-assembly

Modular and pod are two types of volumetric pre-assembly type of construction (Boyd et al., 2013). Modular construction consists of load bearing “building blocks” that are prefabricated room-sized volumetric components typically fully fitted out while being manufactured (Lawson, Ogden and Bergin, 2012). Pods are small volumetric chambers that are produced in factories and then installed on construction sites utilizing light steel frames, wood, concrete, or glassed reinforced plastic (Mapston and Westbrook, 2010). Washrooms, baths, and kitchens are common places to find them (Ross, Cartwright and Novakovic, 2006). In Sri Lanka the National Housing Development Authority (NHDA) had introduced the pod type of construction named ferrocement toilet units.

According to Davies et al. (2018), as compared to traditional construction, modular construction helps reduce the time consumed up to 50 %. Due to difficulties in implementing this method on a large-scale construction project, prefabrication has earned a bad reputation (O'Neill and Organ, 2016). However, it can be achievable since the industrial manufacturing process is not influenced or controlled by the same external variables that impact conventional building, such as bad weather, logistical problems, and a scarcity of trained labour, among others (Agha et al. 2021).

Modular construction requires meticulous planning ahead of time which makes the complexity of the various models and integrating diverse features of the module, transported and installed in its ultimate location conceivable (Choi et al., 2016). The application and acceptance have been sluggish due to a negative public impression on prefabricated structures and a lack of trust in non-traditional building methods (Davies et al., 2018). However, the success of these methods are dependent on the presence of a well-functioning local economy (Kamali and Hewage, 2017). In summary, the usage of off-site building in the construction sector has been limited due to the following factors (Agha et al. 2021; Blumhorst, 2021; Boyd et al., 2013; Musa et al., 2016; Rahman, 2014):

- Cost: Off-site construction are around 7% to 10% more expensive than on-site construction which involves costs of initial setting up, operational, maintenance and certifications.
- Industry capacity: The use of this technology has been hampered by a lack of trained employees and manufacturing capacity to create parts.
- Public awareness: Majority of the public prefer traditional method of construction.
- Transportation issues: Delivery of completely constructed houses or partially built modules require a proper guideline to handle.
- Experts: Lack of specialists in this field.
- Infrastructure facilities: Inability to deliver the houses to the intended location.

## **2. AIM AND OBJECTIVES**

The aim of this research is to explore the applicability of modular construction innovation in residential buildings of Sri Lanka. The findings will help increase the awareness among the readers and traditional builders. The research has several objectives as follows:

- To identify the barriers in modular building construction.
- To identify the challenges in housing construction in Sri Lanka.
- To compare the pros and cons of modular building method with the current method used in housing construction of Sri Lanka.

### 3. METHODOLOGY

A desk review was carried out to identify the pros and cons of the modular construction in accordance with environment, social and economic factors. The barriers in modular construction method were identified through the literature survey. Despite the high number of professionals in the construction industry, knowledgeable professionals in this field are hard to come by. A preliminary interview and six number of structured interviews with housing contractors were conducted to identify the challenges in construction of house in Sri Lanka. To gain comments on the level of application of the modular building approach, a questionnaire survey was conducted using 'Google forms'. On a 5-point Likert scale, Google forms were utilized to collect qualitative data on site level personnel's hands-on experience. The observed frequency was measured using the relative important index (RII) approach. The final summary from RII technique was converted to percentage and displayed in the bar chart.

$$RII = \frac{\sum W}{(A \times N)} \quad (\text{Eq: 01})$$

Where,

RII = relative importance index

W = weighting given to each factor by respondents (ranging from 1 to 5)

A = highest weight (i.e., 5 in this case)

N = total number of respondents

In addition, the 'Cochran Formula' was examined to ensure that findings extrapolated from the sample drawn back to the population are within the bounds of random error.

$$n = \frac{Z^2 P(1-P)}{d^2} \quad (\text{Eq: 02})$$

Where,

n = required sample size

Z = Statistic for a level of confidence (Considered as 90%)

P = Expected prevalence or proportion (Considered as 50%)

d = Precision (Considered as 10%)

### 4. RESEARCH FINDINGS AND DISCUSSION

In accordance with the central bank report of Sri Lanka the annual housing demand is around 100,000 units. It was questioned about the declined yearly rate of 12,000 housing units in the structured interviews. Even though there were too many factors, the interviewees highlighted the following areas as main factors of challenges faced in housing construction in light of their experiences as; increased population, housing loan, limited resource, purchasing power, financial stability of the client, labour shortage, increased rate of fluctuation and the stagnant level of productivity

In addition, all the respondents agreed traditional method as mostly used procurement type in Sri Lanka. The demand for the house units will be increased according to the population growth. Thereby, construction speed needs to be increased which is the foundation of off-site construction methods. In the Questionnaire survey, all respondents were asked to give their opinion on the application of modular

building in the housing sector of Sri Lanka in terms of social, economic and environmental factors. A response rate of 35% has been recorded in the survey. 124 questionnaires were distributed among the staff who were exposed to off-site construction in Middle East countries of which 44 responses were received.

Table 1: Respondents' profile

Professional background	Number of respondents
Engineering	14
Quantity surveying	27
Architect	3

The Figure 1, 2 and 3 provide the social, economic and environment factors based on the survey recorded by providing Likert scale for both modular and traditional methods. The results from the Likert scale were summarised using the RII technique. The final results from the RII technique were converted to percentage and categorised into five: strongly disagree to strongly agree. The following is the average result from the questionnaire survey that can be seen in the graphs:

0% - 20% : Strongly disagree                      20% - 40% : Disagree  
 40% - 60% : Neutral                                      60% - 80% : Agree                                      80% - 100% : Strongly agree

According to the Figure 1, most of the respondents (98%) strongly agreed that speedy construction can be achieved in modular construction. Whereas, 58% of them provided a neutral response to the traditional method. 100% of the respondents strongly agreed that modular construction provides job security compared to contract basis on site. Even though most of the social factors of traditional method have neutral responses, the increased rate of perception among the people was significantly high than the modular construction.

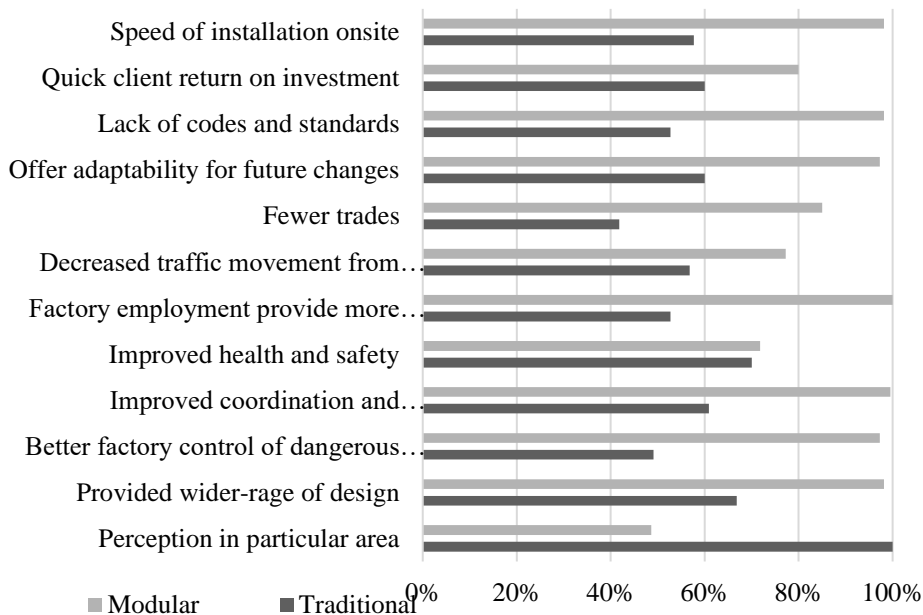

Figure 1: Responses based on social factors

Most of the responses recorded for traditional method indicated in the Figure 2 are neutral responses except for the overall life cycle cost, energy efficiency-in-use, quality, less re-work, on-site organisation, productivity, life span and durability of the final product. These factors fall under category of ‘agree’ and ‘strongly agree’ which are over 60% for modular construction. However, the economic

factors investment, difficulties in long distance transportation, initial cost, cash flow issues and limited suppliers are highlighted as main draw backs for modular construction.

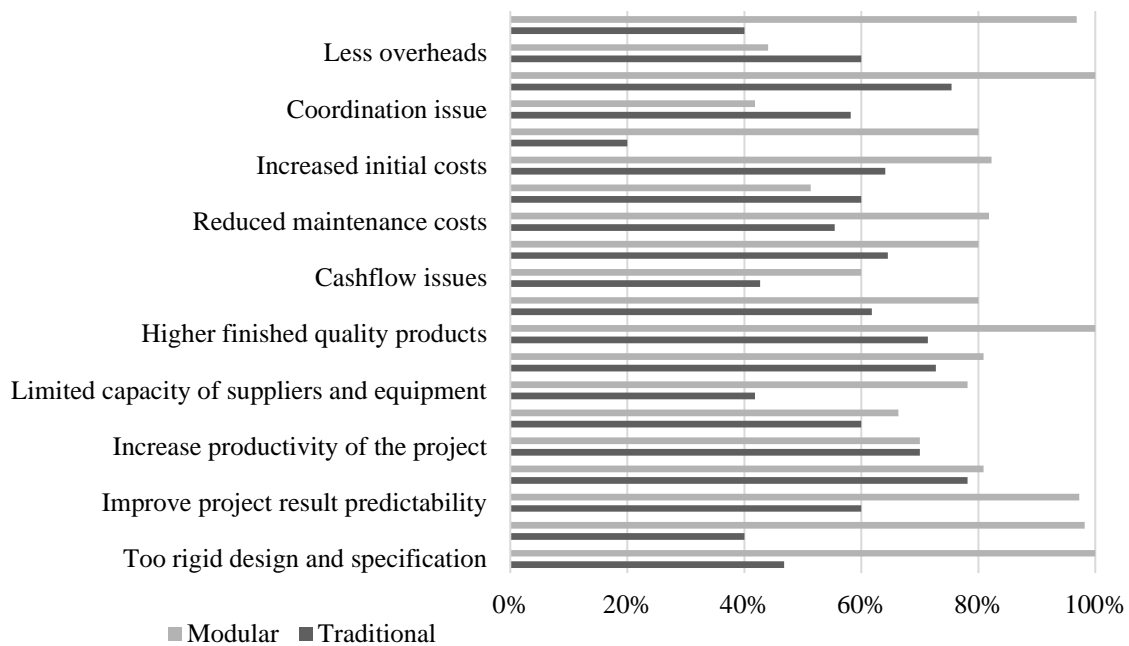

Figure 2: Responses based on economic factors

Figure 3 represents the environment factors. Most of the respondents agreed (over 60%) that the modular construction contributes to the environment comparatively higher than the traditional method. As per the overall responses, it is considered as a sustainable approach. However, it can be seen that it can increase the carbon emission. Nevertheless, difficulties in handling big components and transportation issues are salient factors to be considered in modular construction.

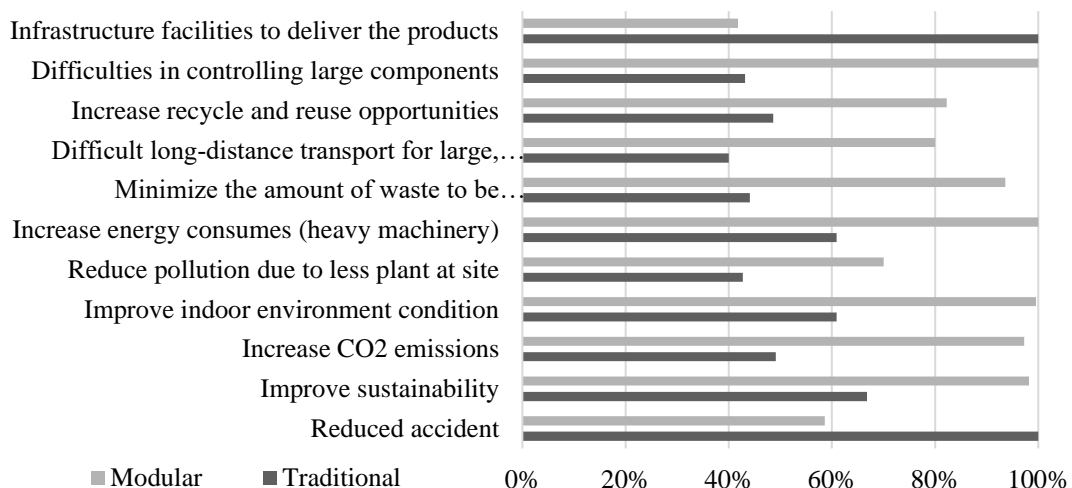

Figure 3: Responses based on environmental factors

The benefits of modular construction outweigh the disadvantages of traditional construction, according to the results of a survey. It has a considerably more complex design with more elaborate details than typical houses. This will enable the structures to be delivered with far fewer complications and site commissioning to be finished much more quickly. More significantly, it eliminates the possibility of

faults not being discovered during construction, which would normally be costly to fix afterward. Modularization allows for the automation of building components as well as excellent coordination across trades. As a result, the time spent assembling on site is considerably decreased. Modular construction allows designers, consultants, and contractors to work together effectively to guarantee that the project's schedule of event is met. Modular method of construction will save money in relation to the life of the building by reducing energy use, faults, and maintenance. When compared to traditional construction methods, modular construction may be a more costly for house building. However, the overall life-cycle cost of modular construction provides cost effective solution.

## 5. CONCLUSION

The modular building approach is a significant breakthrough in the construction business that aims to create new techniques for effectively and swiftly producing residential structures to meet current demand. However, public awareness, capacity of the industry, cost, and knowledge of the experts in particular method, transportation problems, and infrastructure facilities were cited as barriers. Furthermore, the housing loan, population, purchasing power, financial stability, fluctuation, limited resources, labour shortages and stagnant level of productivity were pointed out as issues in housing construction. Traditional contractors are wary about using off-site modular building processes, owing to prior negative impressions. However, primary evidence shows that employing modular building over traditional construction has significant advantages in terms of social, environment and economic factors. These advantages include speedy recovery of investment, reduced traffic movement, improved health and safety, better coordination in management level, factory controlled of dangerous substance, wide range of design, long term job security for the labourers, minimise overall life cycle cost, energy efficiency, less re-work, quality product, less site accommodation, varieties of design, improved indoor quality, reduce pollution on site, reduce the wastage factor, sustainability approach and reduction in accident on site. In conclusion, it will be in the interests of the construction sector in Sri Lanka to adapt such new trends of modular construction in the face of increasing demand for housing.

## REFERENCES

- Agha, A., Shibani, A., Hassan, D. and Zalans, B., (2021). Modular Construction in the United Kingdom Housing Sector: Barriers and Implications. *J Archit Eng Tech*, 10(2), 236.
- Bertram, N., Fuchs, S., Mischke, J., Palter, R., Strube, G. and Woetzel, J., (2019). Modular construction: From projects to products. McKinsey & Company: Capital Projects & Infrastructure, 1-34.
- Blumhorst, J.H., (2021). *Benefits and Barriers of Offsite Construction in Hospital Projects*. Doctoral dissertation, University of Washington.
- Boyd, N., Khalfan, M.M. and Maqsood, T., (2013). Off-site construction of apartment buildings. *Journal of architectural engineering*, 19(1), 51-57.
- Central bank of Sri Lanka, (2020). Annual Report.
- Central bank of Sri Lanka, (2019). Annual Report.
- Choi, J.O., O'Connor, J.T. and Kim, T.W., (2016). Recipes for cost and schedule successes in industrial modular projects: Qualitative comparative analysis. *Journal of Construction Engineering and Management*, 142(10), 04016055.
- Davies, A., Bagust, P. and Basquill, A.M., (2018). Modern Methods of Construction. A Forward-Thinking Solution to the Housing Crisis.
- De Silva, C.S.R., (2017). *Prefabricated building method in Sri Lanka and user attitude*. Doctoral dissertation. University of Moratuwa.
- Ferdous, W., Bai, Y., Ngo, T.D., Manalo, A. and Mendis, P., (2019). New advancements, challenges and opportunities of multi-storey modular buildings—A state-of-the-art review. *Engineering Structures*, 183, 883-893.
- Gosling, J., Pero, M., Schoenwitz, M., Towill, D. and Cigolini, R., (2016). Defining and categorizing modules in building projects: An international perspective. *Journal of construction engineering and management*, 142(11), 04016062.

- Innella, F., Arashpour, M. and Bai, Y., (2019). Lean methodologies and techniques for modular construction: chronological and critical review. *Journal of Construction Engineering and Management*, 145(12), 04019076.
- Kamali, M. and Hewage, K., (2017). Development of performance criteria for sustainability evaluation of modular versus conventional construction methods. *Journal of cleaner production*, 142, 3592-3606.
- Kyjaková, L., Mandičák, T. and Mesároš, P., (2014). Modern methods of constructions and their components. *Journal of Engineering and Architecture*, 2(1), 27-35.
- Latham, M., (1994). Constructing the team: final report of the government/industry review of procurement and contractual arrangements in the UK construction industry.
- Lawson, R.M., Ogden, R.G. and Bergin, R., (2012). Application of modular construction in high-rise buildings. *Journal of architectural engineering*, 18(2), 148-154.
- Mapston, M. and Westbrook, C., (2010). Prefabricated building units and modern methods of construction (MMC). In *Materials for Energy Efficiency and Thermal Comfort in Buildings*, Woodhead Publishing, 427-454.
- Musa, M.F., Yusof, M.R., Mohammad, M.F. and Samsudin, N.S., (2016). Towards the adoption of modular construction and prefabrication in the construction environment: A case study in Malaysia. *Journal of Engineering and Applied Sciences*, 11(13), 8122-8131.
- O'Neill, D. and Organ, S., (2016). A literature review of the evolution of British prefabricated low-rise housing. *Structural Survey*, 191-214.
- Rahman, M.M., (2014). Barriers of implementing modern methods of construction. *Journal of management in engineering*, 30(1), 69-77.
- Ross, K., Cartwright, P. and Novakovic, O., (2006). *A guide to modern methods of construction*. IHS BRE Press.
- Sharma, S., Sawhney, A. and Arif, M., (2017). Parametric modelling for designing offsite construction. *Procedia Engineering*, 196, 1114-1121.
- Weerasinghe, A.S., Ramachandra, T. and Rotimi, J.O., (2021). Comparative life-cycle cost (LCC) study of green and traditional industrial buildings in Sri Lanka. *Energy and Buildings*, 234, 110732.

# Critical Barriers in Implementing Sustainable Construction Methods among Small - Medium Contractors in Sri Lanka

K. D. M. Gimhani<sup>1</sup>, P.L. Perera<sup>2\*</sup>

<sup>1</sup>Department of Quantity Surveying, General Sir John Kotelawala Defence University, Sri Lanka

<sup>2</sup>Department of Civil Engineering, Sri Lanka Technological Campus, Sri Lanka

## ABSTRACT

*Sustainable construction has been a controversial topic in the Sri Lankan construction industry for the last few decades. Even though there is considerably a large domination by the contractors in the small- medium sector, the implementation of sustainable construction methods among them is not prominent due to a variety of impediments. Hence, it is vital to introduce a set of strategies to overcome the critical barriers for Small-Medium contractors to implement sustainability measures in the construction sector of Sri Lanka. The objectives of this study have been realized through a mixed research methodology, which comprises quantitative data collection through a questionnaire survey and qualitative data collection through a literature survey. Data collected through the questionnaire survey was analyzed using the SPSS software to identify the relationship between critical barricades and the enactment of sustainable construction methods among the small-medium contractors. This investigation has exposed that the implementation of sustainable construction methods among the small-medium contractors is impacted by the six main categories of barriers: Financial, Political, Management/Leadership, Technical, and Market & Knowledge/Awareness. Additionally, a set of strategies have been identified & ranked to overcome the barriers.*

**Keywords:** Critical Barriers, Small Medium Contractors, Strategies, Sustainable Construction.

## 1. INTRODUCTION

Sustainable construction has been a controversial topic in the Sri Lankan construction industry for the last few decades. The significant level of attention in commercial sustainability has resulted in a high level of research expenditure, however, most of this research is focused on the application of sustainability measures for massive corporations rather than Small Medium Enterprises (SME) (Álvarez Jaramillo, Zartha Sossa and Orozco Mendoza, 2019). SMEs represent the majority from the worldwide business sector (Conway, 2015). The Sri Lankan government also regards SMEs as the bedrock of the economy, since they constitute more than 75% of total firm numbers, generate 45% of employment, and produce 52% of Gross Domestic Production (GDP) (Ministry of Industry and Commerce, 2015). Though the main contractor of the large building & infrastructure construction has a higher ICTAD grade, most of the time, subcontracting works are done by Small & Medium Contractors. Even though, there is considerably large domination from the small-medium construction contractors to the Sri Lankan economy, the implementation of sustainable development factors among the SMEs are not prominent due to a variety of impediments. In comparison to the environmental implications of larger corporations, the smallest enterprises do not consider their own to be substantial. But collectively, SMEs contribution is significant. It is consequently critical that SMEs must be encouraged and assisted in improving their performance, both in terms of environmental protection and more broadly in terms of sustainable development. The slower adoption speed of sustainability is caused by the presence of several factors that impact SMEs. When it concerns the practical impediments to SMEs embracing environmental management, the challenges appear to be as much as the sector's heterogeneity. Hence, the general aim of this investigation is to introduce a set of strategies to overcome the critical barriers for small-medium contractors to implement sustainability measures in the construction sector of Sri Lanka.

---

\* Corresponding Author: E-mail - [lakkhanap@sltc.ac.lk](mailto:lakkhanap@sltc.ac.lk)



## 1.1 Objectives

The following objectives have been set out for achieving the above-mentioned aim.

1. To identify the critical barriers for small-medium contractors to implement sustainability measures & possible strategies to overcome the barriers in the construction projects.
2. To formulate the interconnection between the critical barriers and the implementation of sustainability measures by the small-medium contractors in the construction projects.
3. To assess the impact of critical barriers to the unwillingness of the small-medium contractors to implement sustainability measures.
4. To assess the most critical tactics to overcome the barriers to implementing the sustainability measures in the construction projects by the small-medium contractors.

## 2. LITERATURE REVIEW

### 2.1 Sustainable Construction (SC)

Due to the compounded nature of both “Sustainable” and “Construction” terms, there are controversial debates that are continuing for the determination of the scope and definition of each term (Plessis, 2007). Although the phrases such as, “green building” and “ecological building” have already long been utilized, during the First International Conference on Sustainable Construction in Tampa in 1994, Charles Kibert offered the first definition of sustainable construction as “The creation and responsible management of a healthy built environment based on resource efficient and ecological principles” (L Bourdeau, 1999).

According to Plessis (2007), no such definition is entirely adequate, although three characteristics of sustainable construction should be outlined in each definition. Such as, construction has to be seen broadly as a crib to grave phenomenon including several more actors than the typical parties of the construction business.

### 2.2 Small- Medium Contractors in Sri Lanka

Different scholars and authors around the world have given several definitions of the term SMEs. Several scholars employ capital assets while others utilize skills in terms of labour and turnover. When considering the Sri Lankan context, according to *National Policy Framework For Small and Medium Enterprises (SMEs) Development Action Plan* (2016) has defined MSMEs contractors for the manufacturing & service sector, based on financial capacity and number of employees as per below Table 1.

Table 1: Defining SMEs in Sri Lanka-National Policy Framework

Sector	Criteria	Micro Level	Small Level	Medium Level
Manufacturing Sector	Annual Turnover (LKR)	>15 Mn.	16-250 Mn.	251-750 Mn.
	No. of Employees	>10	11-50	51 - 300
Service Sector	Annual Turnover (LKR)	>15 Mn.	16-250 Mn.	251-750 Mn.
	No. of Employees	>10	11-50	51 - 300

Source: (*National Policy Framework For Small and Medium Enterprises (SMEs) Development Action Plan*, 2016)

### 2.3 Challenges for Implementation of Sustainable Measures among Small-Medium Contractors

Ametepey, Aigbavboa and Ansah (2015) have identified 27 crucial barriers to implementing sustainable measures by the small-medium contractors and classified those 27 barriers into 6 categories of barriers as listed below.

**Financial barriers:** The implementation of sustainable construction techniques might be restricted because of the increased financial risk concerns of the customers. These expenses are excessive because cost consultants overestimate the capital cost & undervalue possible cost savings (Djokoto, Dadzie and Ohemeng-Ababio, 2014).

**Political barriers:** Numerous scholars have argued that for the SC concept to be more successful, stakeholders such as the government must introduce regulations that require cooperating sustainability initiatives and the establishment of numerous regulatory papers to impose sustainability in all parts of their operation. SC's triumph depends heavily on government participation and legislative formation.

**Management/leadership barriers:** Management and leadership in the construction sector, as well as individual enterprises, perform a vital role in the efficient implementation of innovative concepts. The commitment of management and leadership to develop and implement an effective strategy, as well as to provide the tools and resources required to manage the consequences of execution, is required for successful SC implementation.

**Technical barriers:** There seems to be a dearth of proper instruction on delivering effective sustainable building projects for architects. It is vital for design professionals and the contractors who will eventually be in charge of implementing the design, to be given technical knowledge on sustainable building in the appropriate manner. Accessibility at a reasonable cost to certain knowledge was highlighted by Osaily (2010) as a hurdle to the adoption of such technologies.

**Socio-cultural barriers/ market barriers:** The Sri Lankan construction sector has been operating in a certain pattern for a long time as a sector that is usually very difficult to alter, particularly in the case of development processes and materials (Athapaththu and Karunasena, 2018).

**Knowledge/awareness barriers:** SC might be hampered by ignorance or poor understanding of sustainability. Williams and Dair (2007) discovered evidence of obstruction owing to a lack of knowledge as a typical experience for most of the construction industry stakeholder groups. Stakeholders have stated in numerous situations that they are not aware regarding sustainable practices or options within their competence.

### 2.4 Strategies to Overcome the Hurdles in Implementation of Sustainable Construction

There are numerous strategies highlighted through literature synthesis that suggest advancements to current SC practices in Sri Lanka which have been further elaborated in this study (Ametepey, Aigbavboa and Ansah, 2015). These are the formation of experimental procedures for local enterprises to conduct green innovation, the organization of consultations, trainings, training courses, and sessions on sustainable construction, environmental management remedies, the initiation of green logistics services, the design of operative green initiatives by the state to minimize destruction of the environment, the augmentation of Development and Research perspectives to develop green products, the provision of training facilities, and the provision of training facilities (Ametepey, Aigbavboa and Ansah, 2015; Conway, 2015). Despite that, the scholars have also mentioned the state should deliver subsidies and inducements to small-medium contractors for creating green and development of codes or standards concerning sustainable construction approaches (Ametepey, Aigbavboa and Ansah, 2015).

### 3. RESEARCH METHODOLOGY

#### 3.1 Conceptual Framework

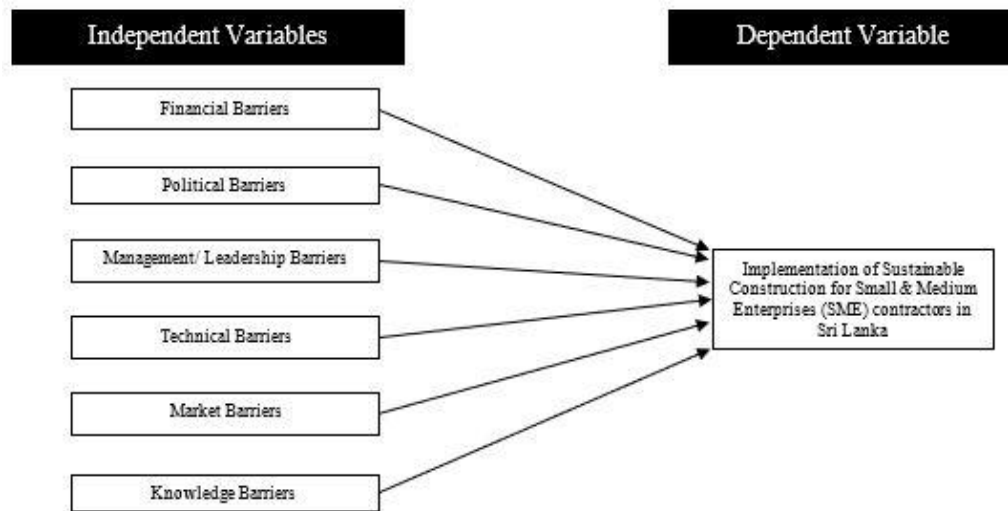

Figure 1: Conceptual Framework

#### 3.2 Hypothesis

HA<sub>1</sub> - There is a relationship between the financial barriers and the implementation of Sustainable Construction for small-medium contractors in Sri Lanka.

HB<sub>1</sub> - There is a relationship between the political barriers and the implementation of Sustainable Construction for small-medium contractors in Sri Lanka.

HC<sub>1</sub> - There is a relationship between the management/ leadership barriers and the implementation of Sustainable Construction for small-medium contractors in Sri Lanka.

HD<sub>1</sub> - There is a relationship between the technical barriers and the implementation of Sustainable Construction for small-medium contractors in Sri Lanka.

HE<sub>1</sub> - There is a relationship between the market barriers and the implementation of Sustainable Construction for small-medium contractors in Sri Lanka.

HF<sub>1</sub> - There is a relationship between the knowledge barriers and the implementation of Sustainable Construction for small-medium contractors in Sri Lanka.

The research methodology is completely based upon the above conceptual framework as illustrated in Figure 1 and the outlined independent and dependent variables of the study. Guest (2013) has emphasized that the mixed research approach consists of the pros of both qualitative & quantitative research approaches. Therefore, the accepted methodology is the mixed research method. According to Naoum (2007) questionnaire survey is an economical and speedy technique for primary data collection and literature surveys acts as a comparison tool for scholars. Therefore, the data was collected through a literature survey & a questionnaire survey for the respective study. The questionnaire was designed in three segments. Namely; Section 1: Overall information about respondents' profession, experience in the construction industry, Number of sustainable building projects involved as a stakeholder, Section 2: Six categories of barriers which includes five barriers to each category for Small Medium Enterprises Implementation of Sustainable Construction methods in construction projects, Section 3: Ten strategies to overcome the identified barriers.

The questionnaire was distributed among the sample population bilingually (Sinhala & English Language), because most of the SMEs who are engaged in the construction business are lack literacy in the English language & most of them are familiar only with the Sinhala language. Further, the study requires to absorb the real impression of the SMEs regarding their identified barriers & ways of overcoming them, which can be easily achieved by asking the questions in their native language. A web-based tool called “Google forms” was utilized for the data gathering for this study to obtain a better response rate. The questionnaire survey was distributed among 100 respondents via emails. The population selected for the study is construction professionals who are involved in the Sri Lankan construction sector. According to Naoum (2007), simple random sampling techniques have been used since there are not any specific characteristics which essentially considered for the sample. Professionals from several disciplines such as Contractors (11 nos), Suppliers/ sub-contractors (5 nos), Quantity Surveyors (13 nos), Engineers (10 nos), Project Managers (10nos), Academia (3 nos) and Architects (8 nos) has responded to the questionnaire. The main reason for selecting professionals from multi-disciplines was to obtain a broad perspective regarding the application of sustainable construction since this process is collaborative. Further, the five-point Likert scale was implemented to retrieve the views of the respondents regarding the 30 identified barriers. Ten strategies to overcome the identified barriers were evaluated by using a five-point Likert scale (5- Most Important to 1- Least Important). 60 responses were retrieved by demonstrating a response rate of 60% which was fit for data analysis. The questionnaire's reliability was assessed by computing the alpha value using the Cronbach's Alpha Reliability test. The questionnaire's reliability is represented as a value between 0 and 1. According to the aforementioned test findings, Cronbach's Alpha value is 0.878, which is more than 0.8. As a result, the internal consistency and reliability of the questions used to measure these variables were deemed satisfactory.

#### **4. DATA ANALYSIS**

##### **4.1 Relationship between the Critical Barriers and Implementation of the Sustainable Construction among Small- Medium Contractors in Sri Lanka**

In this research, all the independent variables were able to achieve a significance value less than 0.05, therefore all the independent variables support the alternative factors. Hence, there is a relationship among all the hurdles and the enactment of sustainable construction methods among the small-medium contractors. Despite that, the financial, political, management/leadership, technical, market & knowledge barriers demonstrate negative relationships respectively of -0.470, -0.383, -0.293, -0.122, -0.374 & -0.346.

##### **4.2 Impact of Critical Barriers to the Enactment of Sustainable Construction Methods among Small-Medium Contractors**

Regression analysis was used for the identification of the impact of critical hurdles to the enactment of sustainable construction methods among the small-medium contractors. To begin, multicollinearity diagnostic test was performed to determine whether or not independent variables are significantly linked among themselves. The person correlation coefficient from the inter-correlation matrix was less than 0.9, and then Tolerance Values and Variance Inflation Factors (VIF) were examined, tolerance values were determined to be greater than 0.2 and VIF values to be less than 5. As a consequence, the tolerance and VIF scores are well within the projected ranges, ruling out multicollinearity. As a consequence, multi regression analysis is possible to conduct. With the item of interest being the  $R^2$  statistics, which is 0.214 with a statistical significance of  $p < 0.5$ , explaining that approximately 21.4 % variance and a significant degree of a link between critical barriers and implementation of sustainable construction methods among small-medium contractors. The Durbin-Watson score was 2.138 and fluctuated between +1 and +3, signifying that the observations were independent. Therefore, the implementation of the sustainable construction methods among the small-medium contractors can be explained through a linear combination of the critical barriers.

Table 2: Coefficients of Independent & Dependent Variables

Coefficients*						
Model		Unstandardized Coefficients		Standardized Coefficients	t	Sig.
		B	Std. Error	Beta		
1	(Constant)	2.912	1.081		2.694	.009
	FB	-.072	.151	-.077	-.477	.035
	PB	-.280	.184	-.212	-1.524	.013
	MB	-.089	.251	.058	-0.356	.003
	TB	-.258	.125	.164	-1.149	.026
	MRB	-.219	.135	-.318	-1.631	.019
	KB	-.055	.169	-.067	-.326	.045

a. Dependent Variable: DV  
 In the above Table 2, FB: Financial Barriers, PB: Political Barriers, MB: Management barriers, TB: Technical barriers, MRB: Market barriers, KB: Knowledge barriers.

The relationship of the above regression model can be explained as follows,

$$Y = \alpha + \beta_1 X_1 + \beta_2 X_2 + \beta_3 X_3 + \beta_4 X_4 \tag{Eq: 01}$$

$$Y = 2.912 + (-0.072 * FB) + (-0.280 * PB) + (-0.089 * MB) + (-0.258 * TB) + (-0.219 * MRB) + (-0.055 * KB) + S.E$$

Where, X1 = FB, X2 = PB, X3 = MB, X4= TB, X5= MRB, X6= KB, α = Constant

According to Table 2 the implementation of the sustainable construction methods among the small-medium contractors decreases by 7.2% with the increase of financial, and with the increase of political barriers, it decreases by 28%. Moreover, with the increase of management/leadership, technical, market & knowledge barriers, the implementation of sustainable construction methods among the small-medium contractors decreases respectively by 8.9%, 25.8%, 21.9% & 5.5%.

### 4.3 Critical Strategies to overcome the Barriers to Implement the Sustainability Measures in the Construction Projects by Small- Medium Contractors

Following Table 3 depicts the RII values & respective ranks for identified 10 strategies to overcome the barriers for Small- Medium Contractors in Sri Lankan construction industry.

Table 3:RII Values of strategies to overcome the barriers for Small- Medium Contractors in Sri Lanka

Strategy No.	Strategy	RII	Ranks
1	Developing research practices to carryout green innovation in small-medium contractors.	0.823	4
2	Organizing discussions, seminars, training programs and workshops on sustainable construction.	0.876	2
3	Developing environmental management systems for monitoring the in small-medium contractors.	0.800	7
4	Setting up of green logistics facilities for small-medium contractors.	0.800	7
5	Designing effective green policies by the government to reduce environmental degradation.	0.813	6
6	Increase Research & Development (R&D) practices to design green products.	0.873	3
7	Training entrepreneurs regarding green processes, green innovation activities and green purchasing for small-medium contractors.	0.900	1
8	The government should provide subsidies and incentives to small-medium contractors for producing green.	0.873	3

<b>9</b>	Involving all the stakeholders in environmental management initiatives and purchasing.	0.800	7
<b>10</b>	Codes or standards relating to sustainable construction practices.	0.817	5

As per the calculated RII values, the provision of the training opportunities for the entrepreneurs regarding green processes, green innovation activities and green purchasing has ranked most prioritized strategy for overcoming the barriers associated with the enactment of Sustainable construction among the small-medium contractors in Sri Lanka and organizing of discussion forums, seminars, training programs and workshops on sustainable construction ranked second. Both, increasing the R&D approaches to plan green products to reduce the knowledge & technical barriers and providing subsidies and incentives to small-medium contractors for constructing green solutions ranked third most prioritized strategy.

## 5. DISCUSSION AND CONCLUSION

The initial objective of this study has been attained through the comprehensive literature review which has identified six major barrier categories in sustainable construction methods for small-medium contractors. All the political barriers have a great consequence on the enactment of sustainable construction methods among the small-medium contractors. It has been proved that due to the thirty (30) barriers which pinpointed, Small- Medium contractors are hustling to implement sustainable construction methods on their scale. As per the values received by calculating the Pearson correlation by using the SPSS software, it is visible that objective 2 of the study has been achieved and all the independent variables have negative relationships with the enactment of Sustainable Construction for small-medium contractors in Sri Lanka. Regression analysis was used to achieve objective three and the numerical results gained through the SPSS software gave a clear picture by illustrating that all the independent variables have a strong negative relationship with the enactment of Sustainable Construction for small to medium contractors in Sri Lanka. Therefore, concerning the above-proven hypotheses mentioned in Table 4 & RII values of Table 3, it is recommended to provide training opportunities to entrepreneurs regarding green processes, green innovation activities and green purchasing to reduce the technical & political barriers along with the organization of discussions, seminars, training programs and workshops on sustainable construction for the Small- Medium Contractors for the enhancement of knowledge or the awareness.

Table 4: Summary of Hypothesis testing

<b>Hypothesis</b>	<b>Supported/ Not</b>
<b>HA1 - There is a relationship between the financial barriers and the implementation of Sustainable Construction for small-medium contractors in Sri Lanka.</b>	Supported
<b>HB1 - There is a relationship between the political barriers and the implementation of Sustainable Construction for small-medium contractors in Sri Lanka.</b>	Supported
<b>HC1 - There is a relationship between the management barriers and the implementation of Sustainable Construction for small-medium contractors in Sri Lanka.</b>	Supported
<b>HD1 - There is a relationship between the technical barriers and the implementation of Sustainable Construction for small-medium contractors in Sri Lanka.</b>	Supported
<b>HE1 - There is a relationship between the market barriers and the implementation of Sustainable Construction for small-medium contractors in Sri Lanka.</b>	Supported
<b>HF1 - There is a relationship between the knowledge barriers and the implementation of Sustainable Construction for small-medium contractors in Sri Lanka.</b>	Supported

## REFERENCES

Álvarez Jaramillo, J., Zartha Sossa, J. W. and Orozco Mendoza, G. L. (2019) 'Barriers to sustainability for small and medium enterprises in the framework of sustainable development—

- Literature review', *Business Strategy and the Environment*, 28(4), pp. 512–524. doi: 10.1002/bse.2261.
- Ametepey, O., Aigbavboa, C. and Ansah, K. (2015) 'Barriers to Successful Implementation of Sustainable Construction in the Ghanaian Construction Industry', *Procedia Manufacturing*, 3(Ahfe), pp. 1682–1689. doi: 10.1016/j.promfg.2015.07.988.
- Athapaththu, K. I. and Karunasena, G. (2018) 'Framework for sustainable construction practices in Sri Lanka', *Built Environment Project and Asset Management*, 8(1), pp. 51–63. doi: 10.1108/BEPAM-11-2016-0060.
- Conway, E. (2015) 'Engaging small and medium-sized enterprises (SMEs) in the low carbon agenda', *Energy, Sustainability and Society*, 5(1). doi: 10.1186/s13705-015-0060-x.
- Djokoto, S. D., Dadzie, J. and Ohemeng-Ababio, E. (2014) 'Barriers to sustainable construction in the Ghanaian construction industry: Consultants perspectives', *Journal of Sustainable Development*, 7(1), pp. 134–143. doi: 10.5539/jsd.v7n1p134.
- Guest, G. (2013) 'Describing Mixed Methods Research: An Alternative to Typologies', *Journal of Mixed Methods Research*, 7(2), pp. 141–151. doi: 10.1177/1558689812461179.
- L Bourdeau (1999) *Report Publication 237: AGENDA 21 on Sustainable Construction*. Rotterdam.
- Ministry of Industry and Commerce (2015) 'National Policy Framework for Small and Medium (SME) Development', *Ministry of Industry and Commerce*, pp. 1–13. Available at: [www.industry.gov.lk/web/images/pdf/framew\\_eng.pdf](http://www.industry.gov.lk/web/images/pdf/framew_eng.pdf).
- Naoum, S. G. (2007) *Dissertation Research and Writing for Construction Students*. 2nd edn. Oxford: Elsevier Ltd.
- National Policy Framework For Small and Medium Enterprises ( SMEs ) Development Action Plan* (2016) *Ministry of Industry and Commerce, Sri Lanka*. Available at: [http://www.industry.gov.lk/web/images/pdf/framew\\_eng.pdf](http://www.industry.gov.lk/web/images/pdf/framew_eng.pdf) (Accessed: 18 July 2021).
- Osaily, N. Z. (2010) *The key Barriers to Implementing Sustainable Construction in West Bank-Palestine*. Zurich.
- Plessis, C. Du (2007) 'A strategic framework for sustainable construction in developing countries', *Construction Management and Economics*, 25(1), pp. 67–76. doi: 10.1080/01446190600601313.
- Williams, K. and Dair, C. (2007) 'What is stopping sustainable building in England? Barriers experienced by stakeholders in delivering sustainable developments', *Sustainable Development*, 15(3), pp. 135–147. doi: 10.1002/sd.308.

# Mechanical Behaviour of Concrete with Recycled Plastics

D.U. Dayananda\*, Kasun Nandapala

Department of Construction Technology, University of Vocational Technology, Sri Lanka

## ABSTRACT

*The consumption of plastic has grown substantially all over the world as well as in Sri Lanka in recent years and this has created huge quantities of plastic-based waste. Although steps have been taken to reduce consumption of plastic, plastic waste has now become a serious environmental threat to the modern way of living. This creates a substantial amount of garbage every day which is a much unhealthy problem. In order to resolve this problem, recycled Polyethylene terephthalate (PET) flakes were proposed to be used as reinforcement material in concrete. This paper discusses the effect of adding PET flakes to the Ordinary Portland Cement (OPC) to manufacture sand mixed concrete. During this research work, the material properties, and the effect of PET flakes on the compressive strength of concrete were analyzed. Initially, the optimum PET flakes proportion was determined by testing 36 (150mm×150mm ×150mm) test cubes. The optimum plastic flakes percentage was found to be 3.0% and the PET flakes percentage was calculated based on the weight of the cement content of the concrete mix. Grade 20 concrete is proposed with 0.55 water-cement ratio with 3% PET flakes content.*

**Keywords:** Compressive strength, Manufactured sand, PET flake, Ordinary Portland cement.

## 1. INTRODUCTION

The most widely used man-made material in the world is concrete. Buildings, bridges, dams, road pavements, sewage systems, tunnels, waste containment systems, and other structures are built using it. Compressive strength is one of its most significant and desirable properties. As a result, concrete is essential to be designed to develop its maximum compressive strength. (Akinwumi & Gbadamosi, 2014). The significant purpose of this study is to combine a waste material with cement to increase concrete's compressive strength.

Plastic is a worldwide substance that has become an integral component of our modern lifestyle, and as a result, global plastic manufacturing has increased in recent decades. PET is a polyethylene terephthalate (PET) that is often used in the packaging of a variety of items. PET containers are light, clear, and impact resistant, and they do not interact chemically with the contents. They are also non-toxic. All of these traits have helped them establish a strong influence in the polymer market and in the worldwide business. (Liliana Ávila Córdoba, et al., 2013).

The usage of excessive plastic has contributed tremendously to the enhancement of plastic-related waste products, which will be a crucial issue in the future. The reuse of waste and recycled plastic materials in the concrete mix design as an environmentally friendly construction material has drawn the attention of researchers in recent times. (Ghernouli, et al., 2014)

(CEA 2019) revealed that the accumulation of the utilized plastics is a pressing problem, which is considered a major cause of health issues, importantly burning of the plastics, contamination of the soil, water, and air. Further, deterioration of the plastics takes an enormous period of time, and these plastics remain in water bodies, and in soil, which will lead to acute environmental related issues. Recycling

---

\* Corresponding Author: E-mail- [upamaldayananda@gmail.com](mailto:upamaldayananda@gmail.com)



waste plastics into useful products is one solution to this problem. Many government agencies, private organizations, and individuals have completed or are in the process of completing a wide range of studies and research projects on the feasibility, environmental suitability, and performance of using waste plastics in the construction field, which requires better and more cost-effective construction materials as well as the reuse of waste plastics to save the environment.

(Sandaruwani et al, 2012) identified that similar variation in compressive strength of PET fiber reinforced concrete. Their study revealed that compressive strength increases with increase of fiber content up to a maximum of 1% and then the compressive strength is decreasing with the increment of fiber content more than that. Rathnayaka (2015) conduct an experiment to determine the compressive and tensile strength of PET fiber reinforced concrete and identified that it has been reduced in compressive strength compared to normal concrete but there's an enhancement in tensile strength up to 3% of PET fiber content. However, there is no study on the application of PET flakes with Ordinary Portland Cement (OPC) in concrete road pavements. In addition, several researchers have been carried out preliminary analysis of concrete reinforced and waste polyethylene terephthalate as lightweight aggregate. (N. Saikia and J. de Brito, 2013)

This research paper aims to provide an investigation of the effect of PET flakes as reinforcement material in the Ordinary Portland Cement (OPC) composite. PET plastic bottles, which are extensively used in the Colombo area, were selected as the reinforcing material. During this research work, the material properties, and the effect of PET flakes on the compressive strength of concrete were analyzed. The optimum percentage of recycled plastic has been determined based on an experimental study. The compressive strength of each variant is determined and develop an economically viable concrete mix design using PET flakes. The waste recycled plastic was mixed with OPC mix design by varying proportions (0%, 1%, 2%, 3%, 4%, and 5%) with respect to weight of cement (Saumyasiri & De silva, 2018)

## **2. AIM AND OBJECTIVES**

### **2.1. Aim**

To use Polyethylene Terephthalate (PET) in the concrete structure as inert material and enhance the mechanical properties of concrete.

### **2.2. Objectives**

- To compare the compressive strength of conventional concrete with waste plastic mix (PET flakes) concrete.
- To investigate the optimum PET flakes percentage for mix design

## **3. METHODOLOGY**

### **3.1 Materials Used**

- Clear Color PET (Polyethylene Terephthalate)
- Cement: Ordinary Portland cement (OPC) was used.
- Sand: Manufacture sand which were sieved from 5mm sieve was used.
- Coarse aggregate: 5-20 mm size aggregate was used.

### 3.2 Pet Flake Concrete Sample Preparation

PET flakes obtained from Viridis Group, Homagama, Sri Lanka was used in the study. PET flakes were added on a weight basis as an inert material. Mix design of concrete was performed according to British (DOE) method (Nevile, 1981). The aggregates were in saturated and surface-dry (SSD) conditions.

### 3.3 Experimental Procedure

G20 concrete mix was used for these trials. Water-cement ratio was kept constant at 0.55. PET flakes were added as 0%, 1%, 2%, 3%, 4% and 5% of the total weight of the cement content of the mix design as shown in Table 1 to investigate the compressive strength test. The mix design of the concrete mix was illustrated in Table 2.

Table 1: PET Flake Concrete Sample Preparation

Trial No	PET flakes weight (% by weight of cement for 0.025m <sup>3</sup> )	Water Cement Ratio
A	0 (Control Sample)	0.55
B	1 (180g)	0.55
C	2 (160g)	0.55
D	3 (240g)	0.55
E	4 (320g)	0.55
F	5 (400g)	0.55

Table 2: Mix Design of The Concrete

Mix Design (1m <sup>3</sup> )	For 0.025 m <sup>3</sup>	
Cement	320 Kg	8 Kg
Water	176 Kg	4.4 Kg
Manufactured Sand	864 Kg	21.6 Kg
Coarse Aggregate	989 Kg	24.73 Kg

The tests of Compressive strength of concrete cubes were performed according to BS EN12390-3:2019 standard, respectively. The load was applied continuously until the specimen failed. Six cubes of (150 mm × 150 mm × 150 mm) specimens were prepared for each mix. The strength of each cube was evaluated after 7, 14 and 28 days, respectively.



Figure 1: Compressive Strength Testing for Cube



Figure 2: Concrete Cube Specimen in After Testing

#### 4. RESULTS AND DISCUSSION

##### 4.1 Variation of Compressive Strength with PET Flake Content

Table 3 shows the difference in compressive strength of concrete cubes with PET flake content. Three specimens were tested, and the average value was calculated. The compressive strength of 3% PET flakes specimens is found to be greater than that of the control specimen. However, increasing the flake concentration further decreased the compressive strength. The results of the compressive strength test are shown in the line graph below. (Figure 3).

In this study, it is confirmed that adding PET flake to the concrete mixture increased the average compressive strength. The addition of 3% gave the maximum compressive strength, irrespective of the period of cure. It is revealed that with higher PET flake content, the workability of concrete was reduced. However, increasing the PET Flake quantity up to 3%, the compressive strength of concrete shows a sudden decrease compared with control samples.

Table 3: Compressive Strength Results for Concrete Cubes

Compressive Strength Test Results N/mm <sup>2</sup>						
Percentage of PET flakes	A-0%	B-1%	C-2%	D-3%	E-4%	F-5%
<b>7 Days</b>	14.38	18.49	18.96	19.56	17.02	15.66
<b>14 Days</b>	19.87	24.00	25.95	26.70	23.75	22.02
<b>28 Days</b>	26.00	27.36	30.42	31.22	26.62	25.87

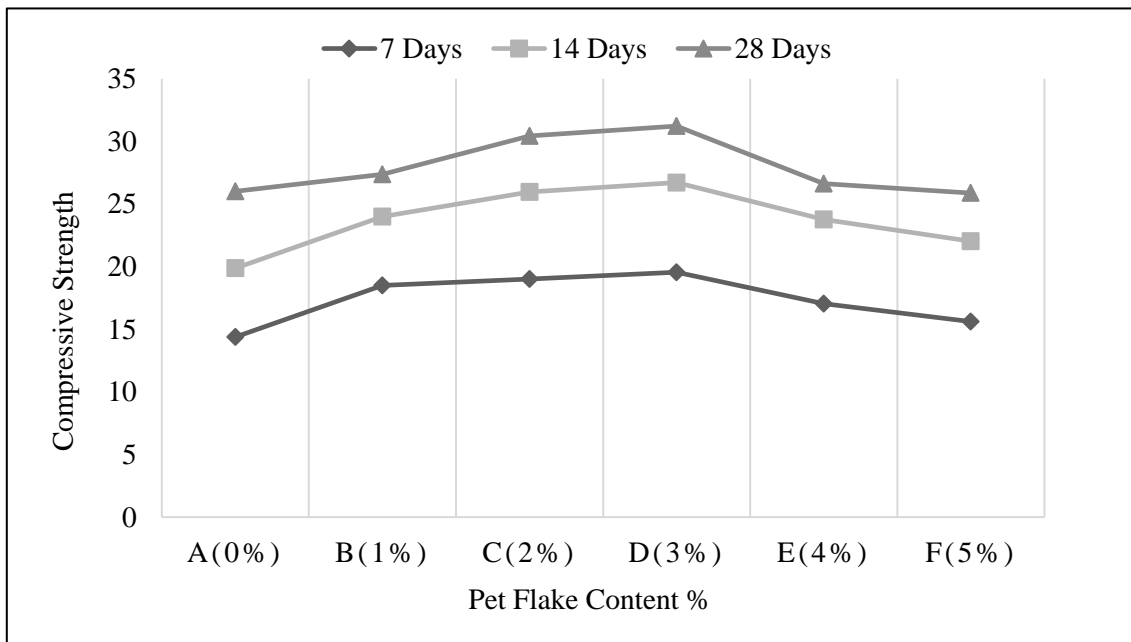

Figure 3: Variation of Compressive Strength with PET Flake Content

#### 4.2 Optimize Mix Design with Optimum PET Flake percentage

From the above observations, 3% PET flake content gives the highest compressive strength results. But this shows that the compressive strength decreases after the plastic exceeds 3%. Two further trials were conducted to make this experiment economically viable. In one mix was tested without PET flakes and in the other only cement was reduced and used 3% PET flakes. There, all other factors were taken to be constant. Comparing the two trial mixes, the compressive strength of 3% PET flake used mix was higher than control mix.

The most commonly used concrete grades by road development authority in Sri Lanka are 20 and 25. Previously used grade 20 mix design with normal and economized for road pavement is shown in Table 4.

Table 4: Economize Grade 20 Mix Design

Materials	1 <sup>st</sup> Mix Design without PET(A)	2 <sup>nd</sup> Mix Design with 3% PET(B)
<b>Cement</b>	320Kg	280Kg
<b>Water</b>	154Kg	176Kg
<b>Fine Aggregate</b>	864Kg	864Kg
<b>Coarse Aggregate</b>	989Kg	989Kg
<b>W/C</b>	0.55	0.55
<b>Concrete Density</b>	2349Kg/m <sup>3</sup>	2287Kg/m <sup>3</sup>

Compressive Strength of each mix was evaluated after 7, 14 and 28 days, respectively. Figure 4 shows strength details.

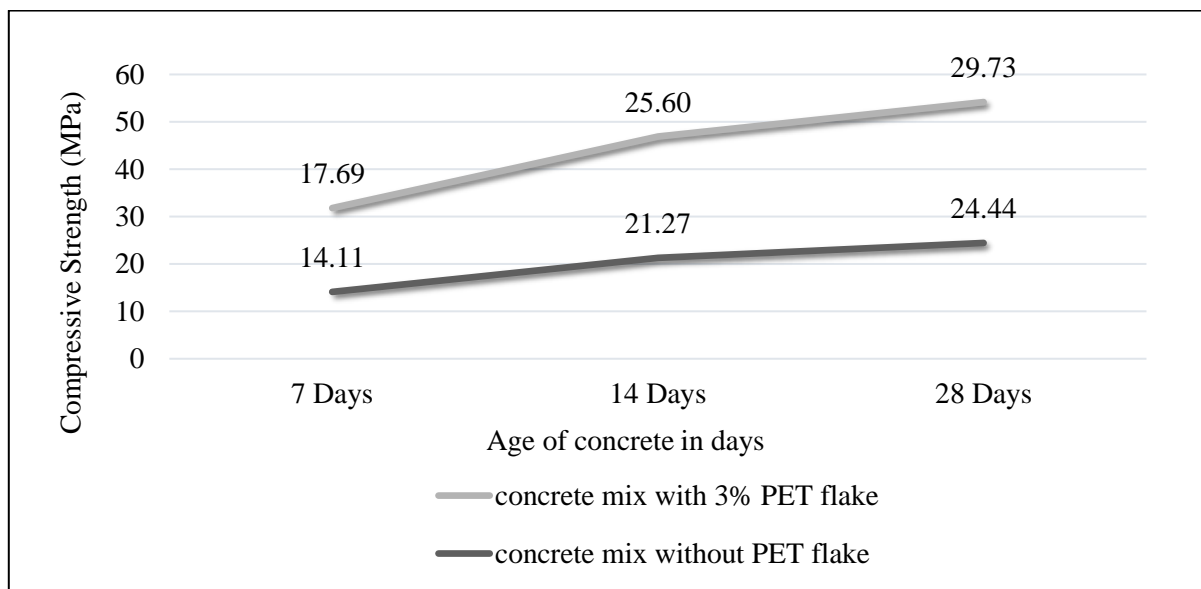

Figure 4: Variation of Compressive Strength with PET Flake Content

According to Figure 4, 3% optimum PET flake concrete sample (B) observed the highest 28 days compressive strength (29.73 MPa) than conventional control sample (A). In addition, by studying this figure can be found that 7 days and 14 days of compressive strength were higher than without PET flake sample. There was significant improvement observed using 3% PET flake with OPC in grade 20 concrete mix design.

## 5. CONCLUSION

According to the results, this production process, achieves to utilize waste plastic to concrete. By considering the compressive strength of recycled PET flake introduced into concrete and the workability of the mix, 3% PET flake content was found as the optimum value for the design of specimens. Based on the Experimental results, the Compressive strength of concrete is affected by the addition of plastic pieces up to 3% and when it is more than 3%, the compressive strength decreases again.

The ultimate compressive strength for the 3% Recycled PET concrete specimen is higher than the control concrete specimen. As a result, it may be concluded that using plastic in concrete can improve its compressive strength. According to the preceding discussion, it is possible to improve the mechanical properties of concrete by using plastic, which may be used as one of the plastic disposal techniques. 3% optimum PET flake concrete observed the highest 28 days compressive strength (31.22 MPa) without even minor cracks on the concrete surface. Grade 20 concrete was proposed with 0.55 water-cement ratio with 3% PET flakes mix for concrete works as a cost effective and crack minimum concrete. However, further research is needed to better understand the durability of the concrete containing PET flakes.

Furthermore, another important advantage of this research is the ability to create an economical concrete mix design for Grade 20 concrete mix. They were able to reduce the amount of cement in the mix design and considerably reduce the cost per  $1\text{m}^3$  of concrete. The biggest advantage is that the destruction of the environment from plastic can be minimized.

## REFERENCES

- Akinwumi, Gbadamosi, Z.O, 2014. ‘International Journal of Civil and Environmental Research (IJCER)’, *Effects of curing conditions and curing period on the compressive strength development of plain concrete*, June. CEA, [Online]. Available: :<<http://www.cea.lk/>>. [Accessed 21 10 2019].
- Ghernouli, Y, Rabehi, B, Safi, B & Chaid, R 2014, Journal of International Scientific publications: Materials, methods, and Technologies’, *Use of recycled plastic bag waste in concrete*, Vol.8, pp.480-487.
- Liliana Ávila Córdoba, Gonzalo Martínez-Barrera, Carlos Barrera Díaz, Fernando Ureña Nuñez, and Alejandro Loza Yañez, 2013. International Journal of Polymer Science ‘*Effects on Mechanical Properties of Recycled PET in Cement-Based Composites*’.
- N. Saikia and J. de Brito, “Waste polyethylene terephthalate as an aggregate in concrete,” *Materials Research*, vol. 16, no. 2, pp. 341–350, 2013.
- Rathnayaka, R. M. M. P., Malshan, W. V. D., De Silva Sudhira & De Silva Subashi, “Incorporating Recycled PET Fibers for Concrete Cylindrical Culverts”, *Proceedings of International Conference on Structural Engineering and Construction Management*, December, 2015, paper no. SECM/15/135.
- Sandaruwani, A. H. W. E., Bandara, K. A. J. M. & De Silva, S., “Investigation on Mechanical Behavior of Concrete with Fibers Made of Recycled Materials”, *Proceedings of International Conference on Structural Engineering and Construction Management*, December, 2012, paper no. SBE/12/81.
- Saumyasiri, PPC, De Silva, S 2018, ‘Application of Blended cement mix fiber concrete for road pavement’, *9<sup>th</sup> International conference on sustainable Built Environment*, 2018 December, Kandy, pp.109-115.

# Potential Species of Plants and Growing Substrates for Roof Greening in Tropical Regions

B.G.R.R Bandara<sup>\*1</sup>, M.P Charithangi<sup>1</sup>, M.D.S.W Goonathilake<sup>2</sup>, H.M.T.P Herath<sup>1</sup>

<sup>1</sup>Division of Mechanical Technology, University College of Kuliyaipitiya, Sri Lanka

<sup>2</sup>Division of Civil Technology, University College of Kuliyaipitiya, Sri Lanka

## ABSTRACT

*The interest towards green roof implementation has highly boosted in tropical cities as a means of mitigating high daytime temperatures and thermal discomforts experienced by urban dwellers. This scientific review plans to evaluate the impact of plant species and growing substrates to enhance the thermal comfort of roof greening through a comprehensive overview of the existing literature. Accounting for plant species selection, height, morphology, thickness of leaves, size of leaves, and color of leaves were identified as the decisive factors in mitigating thermal stress. Sedum, Ipomea pescaprae, Nephrolepis spp and Euphorbiaceae family plants were identified as suitable species for integrating into tropical rooftops. The impact of the substrate media is another significant factor that determines the heat mitigation potentials of rooftop greeneries. Depth and composition of the substrate, water holding capacity and porosity properties were the key factors that determine the thermal performance of a specific substrate. Burned sludge, perlite and peat mixture were revealed as ideal substrates to rooftops of urban landscapes owing to their high thermal performance indices. Hence, the appropriate plant species and substrate selection are vital to optimize the thermal benefits associated with roof greening in the tropical context.*

**Keywords:** Green Roofs, Plant Species, Substrates, Thermal Benefit, Tropical Climate.

## 1. INTRODUCTION

The world urban population is predicted to be increased by 42% by 2100, from 7.7 billion in 2019 to 10.9 billion in 2100 (United Nations, 2019). Due to the population increase, researchers have forecasted that future urbanization will take place in cities located in tropical regions (Roth, 2007). The expansion of cities across the globe is contributing to a significant increase in global warming. When the natural land cover is replaced with the built environment, the structures such as buildings, roads, pavements etc. absorb and retain solar radiation during the daytime and gradually release it at night results a higher temperature increase in next day. Thus, urban areas have significantly higher temperature than the countryside which is called as ‘Urban Heat Island’ (UHI) effect (Lee *et al.*, 2017). This is identified as a climatic phenomenon and anthropogenic modification on land areas, materials with absorption and retaining of solar radiation, energy use and its consequent generation of waste heat have contributed to the higher air temperature in many urban areas (Lee *et al.*, 2017).

Generally, large tropical urban areas have climate-related environmental problems such as (1) high levels of heat stress which decreases productivity and reduces human thermal comfort, (2) lack of ventilation and low wind speeds result in poor diffusion of air pollutants, (3) space cooling needs like air conditioning, which increases energy usage and emission of greenhouse gases (Roth, 2007). Thus, urban greening is immensely important towards sustainable development in tropical regions.

A green roof which is also called a living roof, is a building roof that is partially or completely covered with vegetation and a growing substrate (Xiao *et al.*, 2014). It is consisted of several membranes such as waterproofing, root-barrier, drainage and filter membranes (Kamarulzaman *et al.*, 2014). A waterproof membrane suitable for the load-bearing capacity of the roof, structural and environmental conditions is used for planting vegetation (Xiao *et al.*, 2014). The vegetation layer can be enriched with plants, shrubs, grasses or trees, thereby the natural beauty of the building is reflected from a green perspective. Since roofs cover approximately 20-25% of the total urban surface area the utilization of green roofs provide less energy consumption and thermal comfort to urban dwellers than other greening techniques (Cascone, 2019). Beyond everything, roof greening can mitigate the UHI effect through

---

\* Corresponding Author: E-mail - [ranahansibandara@gmail.com](mailto:ranahansibandara@gmail.com)

evapotranspiration, improve storm water management and air quality by absorbing dust, smog and other pollutants, reduce energy consumption and add ecological value to the urban environments (Ampim *et al.*, 2010). Intensive and extensive green roofs are the main two categories of green roofs. Intensive green roofs have a thick layer of substrate (15cm-150cm), thereby from herbaceous plants to trees, can be planted. Nonetheless, extensive green roofs have a thin layer of substrate (2cm- 20cm) in order to plant mosses, wildflowers, succulents and grasses. Intensive green roofs have high water retention, installation cost and maintenance more than extensive green roofs. Although plants on intensive roofs require irrigation and fertile conditions, plants on extensive roofs grow under low irrigation and poor nutrient conditions (Önder, 2014).

Over the years, researchers have conducted studies on green roof plant types. Climate differences in different regions have resulted in deviations of thermal performances associated with green roof plant species of diverging localities. The tropical climates are characterized by hot and humid weather conditions, recording temperatures above 33°C on the hottest days (Chen, 2013). When selecting plant species for tropical rooftops, it is desirable to find out the levels of surface temperature reductions caused by different plant species, reduction of heat gain caused by different plant types and fluctuations of ambient climatic parameters resulted from green roof plant varieties (Wong *et al.*, 2003). Also, the growth substrate plays a vital role in the functionality of the roof greening and directly influencing for growth of plants (Vijayaragavan, 2016). Open-pore structure, nutrients, mechanical strength, good drainage are principal determinants for plant growth and good substrate meets those requirements due to its characteristics of high nutrient and water holding capacity, low density, and well drainage (DeNardo *et al.*, 2005). Hence, determination of the appropriate substrate is a crucial factor for the success of any type of green roof in any climatological area. Fewer researches have been done on green roofs of tropical regions. This review article aimed to reduce this knowledge gap by evaluating the effect of plant species and substrate types in enhancing the thermal comfort by urban roofs in tropical countries.

## **2. REVIEW APPROACH**

The present study reviewed the existing global literature that includes different sources such as original research articles, review articles, books, project proposals, etc. that have been written on urban greening and green roof technology. Different journals, conferences, open access, and Google scholar platforms were used to find the sources of literature based on the suitable keywords (Eg: urban greening, green roof plants, and substrates, UHI). Accordingly, this review provides information regarding the significance of roof greening as an urban greening technology while emphasizing the importance of suitable plant species and substrate selection to amplify its thermal benefits to the urban microclimate of the tropical regions through a comprehensive overview of reported research findings.

## **3. POTENTIAL PLANT SPECIES TO USE FOR TROPICAL GREEN ROOFS TO ENHANCE THEIR THERMAL BENEFITS**

The climate is a crucial factor to consider when choosing the species of plants for green roofs to optimize its benefits on thermal improvements (Wong *et al.*, 2003). Building carrying capacity, plant diversity, growth stability, pest resistance, pollutant and drought tolerance, level of root penetration could be regarded as the other consequential factors to be considered in plant species assortment for tropical rooftop greening (Xiao *et al.*, 2014). Accordingly, *Sedum* plants became a prominent choice over many areas owing to its adaptability to varying climatic conditions (Villarreal and Bengtsson, 2005). They comprised of low maintenance requirements, drought tolerance accounting to its xerophytic growth habit and good surface coverage that resulted in effective control over storm water runoff (Xiao *et al.*, 2014; Blanusa *et al.*, 2013). Chow *et al.*, (2018) identified the importance of using native plant species considering their high level of adaptability to local climatic conditions. With this implicit assumption, Butler *et al.*, (2012) investigated the concept of postulation that natives are better than adopted plant species. Accordingly, high capacity shown by the native plants to mix with natural ecosystems, adaptability to the local environment with low fertilizer, irrigation and other maintenance requirements, increased biodiversity and recreational benefits and low rate of invasiveness were identified as the significant characteristics of native over non-native plant species for green roofs of a

specified geographic area. Nevertheless, Szabó (2016) defined that non-native species comprised of long-term existence and a high rate of adaptability to extensive green roof conditions compared to native plant species. Therefore, the use of native plant species is of blended nature. However, since the green roof potentials are tremendously influenced by the long-term stability of the plant species, the selection of appropriate plant varieties is an important factor (MacIvor and Lundholm, 2011). Since tropical climates are experiencing a high level of daytime temperatures and solar radiations, it is essential to concern about the degree of temperature and solar radiance tolerance levels of the plant types (Chen, 2013). Accordingly, table 1 summarizes some high temperature and solar radiation tolerant plant species that can be successfully adopted for tropical climate regions.

Table 1: Suitable species of plants for Green Roofs in Tropical Climates

Plant Species	Description	Reference
<b>Sedum family:</b> <i>Sedum pachyphyllum</i> , <i>Sedum spurium</i> and <i>Sedum clavatum</i>	Succulents are CAM plants that open stomata during the night for CO <sub>2</sub> uptake and remains closed during day time to avoid water loss by transpiration. Ability to survive for 113 days without water. Depends on the substrate type. Suitable for hot and dry climates	(Farrell <i>et al.</i> , 2012).
<b>Crassulaceae, Euphorbiaceae and Portulacaceae, family plants</b>	CO <sub>2</sub> fixation by CAM pathway. Hence, susceptible to water stress and suitable for humid subtropical climates	(Liu <i>et al.</i> , 2012).
<b>Crassulaceae, Portulacaceae and Neoregelia family plants</b>	Appropriate species for tropical Malaysian climate	(Fauzi <i>et al.</i> , 2013).
<b>Ferns (Nephrolepis spp), grasses and vines</b>	Native plant species in tropical regions. Have a wide leaf coverage and growth stability on green roofs of tropical climate	(Rey <i>et al.</i> , 2020).
<b>Sweet potato (Ipomoea batatas), arrowhead plants (Syngonium podophyllum), cardinal creeper (Ipomoea horsfalliae), morning glory (Ipomoea pescaprae)</b>	Suitable plant species for green roofs of tropical climates and ability to withstand high temperatures and intake high levels of atmospheric CO <sub>2</sub> .	(Ismail <i>et al.</i> , 2011; Fauzi <i>et al.</i> , 2013).

Moreover, it is crucial to concern their potentials in mitigating the thermal stress associated with the urban setting. Ismail *et al.*, (2011) investigated the cooling potential of green roofs and white roofs in the Malaysian tropical climate and tested five different plant species named *Syngonium podophyllum*, *Ipomoea batatas*, *Ipomoea horsfalliae* and *Ipomoea pescaprae* that are well adapted for the tropical climatic conditions to integrate into the experimental green roof. Then, *Ipomoea pescaprae* has been selected to incorporate into experimental green roofs considering the associated thermal benefits of this plant resulted from its capability to uptake higher amounts of CO<sub>2</sub> and it can tolerate high outdoor temperatures. Furthermore, Liu *et al.*, (2012) investigated the thermal performance associated with ten different tropical plant species considering their heights, morphology, the thickness of leaf, size of the leaf, and color of the leaf as summarized in Table 2.

Table 2: Details About Plant Species Used To Test The Thermal Performance On Green Roofs (Modified From Liu *et al.*, 2012)

Plant Species	Origin of the plant	Height	Morphology	Thickness of the leaf	Size of the leaf	Leaf Color
<i>Zoysia matrella</i>	Tropical Asia	Medium	Erect	Thick	Small	Green
<i>Kalanchoe garambiensis</i>	A native species to low lands of tropical Taiwan and suitable for tropical and subtropical climates (Kuang <i>et al.</i> , 2021)	Medium	Erect	Thick	Medium	Green/Purple
<i>Ipomoea batata</i>	Tropical regions of America	Medium	Creeping	Thin	Medium	Green/Purple
<i>Torilis japonica</i> (Houtt.) DC	Tropical regions of South America	Medium	Creeping	Thin	Small	Green
<i>Bryophyllum pinnatum</i> Lam. Kurz	Tropical regions of Africa	High	Erect	Thick	Medium	Green



<b>R. spathaceo cv. Compacta</b>	Suitable for extensive green roofs in tropical climates (Lin and Lin, 2011).	Medium	Erect	Thin	Small	Green
<b>Sedum lineare cv. 'robustum'</b>	Grows well under high temperature, humid climates (Liu <i>et al.</i> , 2016)	Low	Erect	Thick	Small	Green
<b>Ixora williamsii cv</b>	Tropical regions of Asia	High	Erect	Thin	Small	Green
<b>Sansevieria trifasciata cv. Hahnii</b>	Tropical regions of Africa and Asia	Medium	Erect	Thick	Medium	Green
<b>Callisia repens L</b>	Tropical regions of America	Low	Creeping	Thick	Small	Green

Hence, it has been studied the cooling effect of different plant species by measuring the degree of temperature decrease beneath the plant and the ground temperature and they have predicted *S. trifasciata* cv. Hahnii, the plant species with the highest mean difference of temperature, 17.9 °C followed by *Ixora williamsii* cv and *Bryophyllum pinnatum* Lam. Kurz, respectively. Further, *B. pinnatum* plant species with a 35 cm mean height has recorded a maximum temperature reduction of 22.9 °C with an average temperature reduction of 16 °C. That proved the fact that higher plants with more leaf layers provide good coverage to prevent the solar radiation from reaching the ground compared to plants with low heights (Castelon *et al.*, 2010). In addition, they have analyzed the effect of leaf colors on the thermal performances of plant species using *I. batata* with different leaf colors. Based on the results, a 4.2 °C temperature reduction beneath the leaves of green *I. batata* and a higher temperature beneath the leaves compared to the surface in purple-colored *I. batata* plants. Hence, it was proved that plants species comprised of green-colored leaves are more efficacious against mitigating thermal stress and are more suitable to integrate into urban rooftops. Moreover, Blanusa *et al.*, (2013) suggested that plant species *Stachys* as an ideal alternative to replace *Sedum* that was widely used in rooftop greening. It was a significant finding for tropical green roof planting as some of the *Sedum* plant varieties are growing well only on temperate climate conditions (Zhao *et al.*, 2014). The *Stachys* plant species have been proved that the presence of hairs on the leaves of *Stachys* plants works on preventing the infrared radiation falling on leaf surfaces by reflecting the incoming irradiance. So, it performs well in mitigating heat stress while preserving the level of plant moisture. However, its ability to decrease the ambient temperature depends on its canopy characteristics and the cooled air masses releasing through transpiration. Accordingly, to predict the level of cooling potential, the substrate surface temperature underneath the canopy has been correlated with the Leaf Area Index (LAI). The results have indicated that at similar values of LAI, the substrate surface temperature under *Stachys* plant canopies was only 1°C higher than that of *Sedum* plants. Thus, *Stachys* was selected as a suitable alternative to replace *Sedum* in regions with comparatively high daytime temperatures (Blanusa *et al.*, 2013).

The next part of this scientific review will focus on the potential substrates for tropical green roofs to enhance their thermal benefits.

#### 4. POTENTIAL GROWING SUBSTRATES TO USE FOR TROPICAL GREEN ROOFS TO ENHANCE THEIR THERMAL BENEFITS

As substrate has numerous benefits, it is not practicable to expect all properties from one substrate. The most practicable way is mixing the components with defined ratios to prepare a well-constituted growth medium. Commercial substrates are widely utilized. (Vijayaragavan, 2016). Particular substrate weight per unit area (kg/m<sup>2</sup>) can vary with range of 12 – 14 and its thickness is 8 cm for the extensive green roofs. On the other hand, for the intensive greening roofs, substrate weight per unit area (kg/m<sup>2</sup>) and recommended thickness (cm) are 600 and 50-60 respectively. (Cascone, 2019). Density of the substrate, size of the particles, water absorptivity and highest rates of water volume and air volume in saturation are important physical parameters while electrical conductivity, pH index, amount of organic matters are considered as chemical parameters (Cascone, 2019). Substrate depth and composition have a significant effect especially for the rainwater retention and thermal load reduction on the roof (Andrea.

et al., 2012). Water availability, seasonal low temperature values and type of vegetation are key factors that determine the depth of this growing media (Moran et al., 2005).

Vanwort et al., (2005) examined that escalate of the plant coverage rate, insulation efficiency and water holding capacity of the greening roof are improved by increasing the substrate depth. Vegetation cover, climatic conditions, irrigation methods and geometry of the roof are key components to determine the thickness and weight of the particular substrate (Cascone, 2019). Jim and Peng (2012) examined substrate’s moisture behavior on the evapotranspiration, subaerial, subsurface temperatures, water balance for the tropical extensive type green roofs. It has been conducted for same substrate under three different weather and moisture conditions (wet, moist and dry) and analysis of correlation was explored to measure the association of substrate moisture level with thermal performance indicators. It was shown a strong relationship between the moisture content and thermal behavior of substrate for regulating the temperature of green roofs. However, substrate moisture is less effective for enhancing evapotranspiration and associated cooling. They have provided further moisture dimensions for substrates to improve designing and managing practices on green roofs in relation to behavior of moisture and thermic conditions (Jim and Peng 2012).

Lin and Lin (2011) had demonstrated most beneficial way to supply highest heat insulation level and efficiency of moisture usage by using three different parameters under specific climatic contexture of the tropical region. They have selected four types of substrates, three types of irrigation systems and various drought tolerating plant species for the extensive green roof as a long-term investigation. Four different substrates were sand (20 kg per each), mixture of sand and debris of white charcoal, decomposed organic matters called as man mixed and burned sludge taken by reservoir. The advantages and reasons for the selected substrates are tabulated in Table 03. Accordingly, the greatest thermal deduction percentage was recorded by burned sludge under surface of the roof slab result in an increase up to 84.4%. The highest thermal deduction rate was recorded by burned sludge substrate on both top surface of root and under surface of the roof slab as 88.8% and 75.3% respectively. The highest water holding capacity and porosity properties of the burned sludge are reasons for these results. Even though best percentage for thermal deduction and highest lagged period were recorded by the man–mixed substrate, taken more time to decompose which leads to an increase in the maintenance and management loads of extensive green roofs. This study concluded that the burned sludge as planting substrate for green roofs of tropical regions.

Table 03: Advantages of Selected Substrates (Lin and Lin, 2011)

Type of the Substrate	Reasons for Utilizing
<b>Sand</b>	High availability, Favourable for Crassulacean Acid Metabolic Plants (CAM plants) as high growing potential in tropical region (Especially succulent plants)
<b>Sand: White Charcoal Debris ;(5: 1) mixture</b>	Maximize the water holding capacity and favourable for control pests
<b>Man Mixed Decomposing Organic matter Ratio of Moss of peat, Clay (Burned) and Vermiculite 1: 1: 1</b>	Light weight. Can be decomposed eventually
<b>Burned Reservoir Sludge. Mud builds up in the bottom of the reservoir mixed with rice hull, finally sintered 900°C</b>	High water holding capacity

Sandavol et al., (2015) used four different substrates, sandy loam soil (S1), Perlite and Peat mixture (S2), Crushed bricks (S3) and mixture of top soil and mineral soil (S4) concerning its hydraulic properties and thermal proprieties then presented a numerical simulation of heat flow and fluid flow to study the performance of green roof. As per the results, least increment of the thermal conductivity was recorded by S3 substrate due to an increase in moisture and it has approximately two times increment of their thermal conductivity than its dry thermal conductivity. Hence, the most appropriate thermal resistance is provided by the S3 substrate than other three substrates which are prone to dissipation daily

thermal changes caused by environmental conditions. Moreover, S2 substrate was more applicable to green roofs than S4 due to its low thermal conductivity. Thus, S4 substrate has the ability to retain more water than the others to reduce rainwater runoff and enhance thermal comfort.

Mirnezhad *et al.*, (2017) measured the parameters of solar rays, air temperatures of outdoor and surface to evaluate the green roof substrate thermal behavior with varying thicknesses using two substrates (soil) with two different thicknesses (12 cm and 28 cm) and a bare roof were used. The most effective way to minimize the air temperature of indoors was utilizing vegetation with thicker growing media and results showed that ambient temperature of air was reduced 1-2 °C on the above green roof than bare roof and the highest temperature value was recorded by hard roof with the range of 24.9 – 60.7 °C. Compared with two substrates of different thicknesses, the minimum temperature value was shown by the highest thickness substrate varies from 27.4 – 37.5 °C while the temperature of the minimum thickness substrate varies from 29.1 – 35.2 °C. Hence, findings of research suggest, thicker green roof substrates are more beneficial to moderate the temperature in tropical climates.

The effect of substrates and plant species on the thermal behavior of green roofs in the tropics was studied by Tan *et al.*, (2017). The green roof surface temperature and plant were evaluated with respect to the two treatments (substrate type and absence /presence of moisture detention layer). Normal and K type soil (K type soil -substrate made by artificially) were used as two different substrate types. The purpose of utilizing the artificial substrate was its lightweight and coarse particles of this media lead the drain off conditions and reduced damages to the geotextile membrane. Ultimately, a substantial reduction of the temperature could be observed with K – soil substrate at the mulch layer under the condition of well-watering and surface temperature favor to be higher with top soil as substrate. Jim and Tsang (2011) proved that the depth of the substrate of 0.1 m has the ability to reduce the heat penetration substantially.

## 5. CONCLUSION

This review paper scientifically compares the thermal comfort property of the green roofs in tropical regions concerning the plant types as well as substrate types. As per the previous researches, it is proved that type of plant species and substrates are factors which govern for the maximization of thermal comfort of green roofs in urban dwellers of the tropical region. The findings of the work can be concluded as below:

*Sedum* plants are often the most prominent plant species for green roofing due to their high adaptability during harsh climatic conditions, low maintenance requirement and drought tolerance property and so on. With regard to the high level of adaptability to local climates, researchers recently showed that native plants are best suited for the green roofs, but it is a matter of debate. *Ipomea pescaprae* species are particularly important for urban areas in tropical regions due to their ability to uptake a higher amount of CO<sub>2</sub> in addition to withstand high outdoor temperatures. Moreover, plant characteristics such as morphology and height of the plant as well as color, size and thickness of the leaf are decisive factors in thermal stress dissipation. Since some of the *Sedum* plants under tropical green roofs show less performance, it is recommended to use *Stachys* plants instead of *Sedum* plants.

Type of the substrates also could significantly influence the mitigation of thermal stress. Commercial substrates are recommended instead of conventional soil substrate. Depth, composition of the substrate, water holding capacity and porosity are decisive physical characteristics of the substrates that determine the thermal load reduction in the green roofs. The use of vegetation with dense growing media has the effect of reducing the indoor air temperature. Burned sludge is one of the greatest substrates for the tropical region. Moreover, perlite and peat mixture substrate are also recommended for the green roofs of tropical climates from the low thermal conductivity point of view.

## REFERENCES

Ampim P.A.Y, Sloan J.J, Cabrera, R.I, Harp D.A and Jaber F.H (2010) ‘Green roof growing substrates: Types, ingredients, composition and properties’, *Journal of Environmental Horticulture*, 28(4), 244–252.

- Andrea N, Andri S and Crasso M (2012) 'Influence of substrate depth and vegetation type on temperature and water runoff mitigation by extensive green roofs: shrubs versus herbaceous plants', *Journal of Urban Ecosystems*, 15(3), 697–708.
- Blanusa T, Vaz Monteiro M.M, Fantozzi F, Vysini E, Li Y and Cameron R.W.F (2013) 'Alternatives to Sedum on green roofs: Can broad leaf perennial plants offer better "cooling service"?', *Journal of Building and Environment*, 59, 99–106.
- Butler C, Butler E and Orians C.M (2012) 'Native plant enthusiasm reaches new heights: Perceptions, evidence, and the future of green roofs', *Journal of Urban Forestry & Urban Greening*, 11(1), 1–10.
- Cascone S (2019) 'Green Roof Design: State of the Art on Technology and Materials', *Journal of Sustainability*, 11(11), 3020.
- Castleton H.F, Stovin V, Beck S.B. and Davison J.B (2010) Green roofs; building energy savings and the potential for retrofit. *Energy and buildings*, 42(10), 1582-1591.
- Chen C.F (2013) 'Performance evaluation and development strategies for green roofs in Taiwan: A review', *Journal of Ecological Engineering*, 52, 51–58.
- Chow M.F, Bakar M.F.A and Wong J.K (2018) 'An overview of plant species and substrate materials or green roof system in tropical climate urban environment', *AIP Conference Proceedings*, 2030, 020004.
- DeNardo J.C, Jarrett A.R, Manbeck H.B, Beattie D.J. and Berghage R.D (2005) 'Stormwater Mitigation and Surface Temperature Reduction by Green Roofs', *Transactions of the ASAE*, 48(4), 1491-1496.
- Farrell C, Mitchell R.E, Szota C, Rayner J.P and Williams N.S.G (2012) 'Green roofs for hot and dry climates: Interacting effects of plant water use, succulence and substrate', *Journal of Ecological Engineering*, 49, 270–276.
- Fauzi M.A, Malek N.A and Othman J (2013) 'Evaluation of Green Roof System for Green Building Projects in Malaysia', *World Academy of Science, Engineering and Technology International Journal of Environmental, Ecological, Geological and Mining Engineering*, 7, 75–81.
- Ismail A, Samad M.H.A and Rahman A.M.A (2011) 'The investigation of green roof and white roof cooling Potential on single storey residential building in the Malaysian climate', *International Journal of Architectural, Civil and Construction Sciences*, 76, 129–137.
- Jim C. Y and Peng L. L. H (2012) 'Substrate moisture effect on water balance and thermal regime of a tropical extensive green roof', *Journal of Ecological Engineering*, 47, 9–23.
- Jim C. Y and Tsang S. W (2011) 'Biophysical properties and thermal performance of an intensive green roof', *Journal Building and Environment*, 46(6), 1263-1274.
- Kamarulzaman N, Hashim S.Z, Hashim H and Saleh A.A (2014) 'Green Roof Concepts as a Passive Cooling Approach in Tropical Climate- an Overview', *E3S Web of Conferences*, 3, 01028.
- Kuang Y, Lu C.H and Hsu F.C (2021) 'Restoring fertility for novel interspecific hybrids between *kalanchoe garambiensis* and *K. Nyikae* using colchicine treatment', *Journal of Plants*, 10, 1–16.
- Lee Y.Y, Ponraj M, Din M.F.M, Noor Z.Z, Iwao K and Chelliapan S (2017) 'Overview of Urban Heat Island (UHI) Phenomenon towards Human Thermal Comfort', *Journal of Environmental engineering and management journal*, 16(9), 2097–2111.
- Lin Y.J and Lin H. T (2011) 'Thermal performance of different planting substrates and irrigation frequencies in extensive tropical rooftop greeneries', *Journal of Building and Environment*, 46(2), 345–355.
- Liu S, Yuan C, Xuan T and Chen Z (2016) 'Research Progress on the Resistance of Roof Greening Plant', *Proceedings of the 2016 6th International Conference on Machinery, Materials, Environment, Biotechnology and Computer*, 774–777.
- Liu T.C, Shyu G.S, Fang W.T, Liu S.Y and Cheng B.Y (2012) 'Drought tolerance and thermal effect measurements for plants suitable for extensive green roof planting in humid subtropical climates', *Journal of Energy and Buildings*, 47, 180–188.
- MacIvor J.S and Lundholm J (2011) 'Performance evaluation of native plants suited to extensive green roof conditions in a maritime climate', *Journal of Ecological Engineering*, 37(3), 407–417.
- Mirnezhad M, Aminudin A.M.R. and Yeap K.S (2017) 'Thermal performance and temperature mitigation towards application of green roof in tropical climate', *Journal Chemical Engineering Transactions*, 56, 397-402.

- Moran A, Hunt B and Smith J (2005) 'Hydrological and water quality performance from green roofs in Goldsboro and Raleigh, North Carolina', *Green Roofs for Healthy Cities Conference*, Washington, DC, July, 2005, 4-6.
- Önder S (2014) 'Advances of Green Roofs for Environment in Urban Areas', *Türk Tarım ve Doğa Bilimleri*, 7(7), 2068-2074.
- Rey C.V, Franco N, Peyre G. and Rodríguez J.P (2020) 'Green Roof Design with Engineered Extensive Substrates and Native Species to Evaluate Stormwater Runoff and Plant Establishment in A Neotropical Mountain Climate', *Journal of Sustainability*, 12(16), 7–9.
- Roth M (2007) 'Review of Urban Climate Research in (Sub) Tropical Regions', *International Journal of Climatology*, 27(14), 1859–1873.
- Sandavol V (2015) 'Impact of the Properties of a Green Roof Substrate on Its Hydraulic and Thermal Behavior', *6th International Building Physics Conference, IBPC 2015*, 1177 – 1182.
- Szabó K (2016) 'The Potential Roles of Biodiverse Green Roofs in The Extending Urban Green Network', In *Proceedings of the Fábos Conference on Landscape and Greenway Planning*, 5(1), 14.
- Tan C.L, Tan P.Y, Wong N.H, Takasuna H, Kudo T, Takemasa Y, Lim C.V.J. and Chua H.X.V (2017) 'Impact of soil and water retention characteristics on green roof thermal performance', *Journal of Energy and Buildings*, 152,830–842.
- Vanwort N.D, Rowe D.B, Andresen J.A, Rugh C.L and Xiao L (2005) 'Watering Regime and Green Roof Substrate Design Affect Sedum Plant Growth', *HortScience*, 40(3), 659-664.
- Villarreal E.L and Bengtsson L (2005) 'Response of a Sedum green-roof to individual rain events', *Journal of Ecological Engineering*, 25(1), 1–7.
- Wong N.H, Chen Y, Ong C.L and Sia A (2003) 'Investigation of thermal benefits of rooftop garden in the tropical environment', *Journal of Building and Environment*, 38(2), 261–270.
- Xiao M, Lin Y, Han J and Zhang G (2014) 'A review of green roof research and development in China', *Journal of Renewable and Sustainable Energy Reviews*, 40,633–648.
- Zhao M, Tabares-Velasco P.C, Srebric J, Komarneni S and Berghage R (2014) 'Effects of plant and substrate selection on thermal performance of green roofs during the summer', *Journal of Building and Environment*, 78, 199–211.

# Rain Water Harvesting System to Supplement Non-Potable Water Requirements - Designing Domestic Dwelling in Colombo Suburbs

K.D.C Nimalka<sup>\*1</sup>, B.B.L.R Rathnasena<sup>1</sup>, D.D.D. Suraweera<sup>2</sup>

<sup>1</sup>Department of Construction Technology, University of Vocational Technology, Sri Lanka

<sup>2</sup>Department of Electrical and Electronics Technology, University of Vocational Technology, Sri Lanka

## ABSTRACT

*The National Water Supply and Drainage Board provides potable water. Although it has drinking water quality, standard domestic dwellers use this drinking quality water for several non-potable water requirement purposes such as bathing, washing, cooking, toilet flushing & gardening. This research expects to design a rainwater harvesting system for typical domestic dwellings in Colombo suburbs for non-potable water requirements to reduce the usage of potable water for non-potable water purposes. To achieve this target previous data within ten years on rainfall from three Colombo suburbs were analyzed. In the study, it was observed that the cylindrical shape is the most suitable tank shape & the Ferro cement tank is the most suitable as a storage tank compared to concrete, Ferro cement & plastic considering the life cycle cost analysis. A percentage from the total consumption of 53.06% of potable water consumption for a year can be saved by introducing rainwater harvesting system for domestic dwellings in the Colombo suburbs. Rainwater harvesting shall save potable water despite the population growth. Further, there will not be a requirement of the expansion of water treatment plants.*

**Keywords:** Non-potable water, Potable water, Rainwater harvesting system.

## 1. INTRODUCTION

The growing population and development activities such as rapid urbanization, industrialization create water stress. Colombo district is the most urbanized and populated district in Sri Lanka. Thus, Colombo city residents face the scarcity of land and they have limited access to the use of well water and other resources for fulfilling their water requirements. Hence, most of the people consume piped born water which is provided by the National Water Supply and Drainage Board (NWS&DB).

The NWS&DB provides potable water. Although it has drinking water quality, standard domestic dwellers use that quality water for several domestic purposes such as bathing, washing, cooking& toilet flushing. Nowadays, water supply has become a vital issue globally. But for the all-water requirements, water quality need not be as same as drinking water quality. Pitt & Clark (2011) have explained drinking and cooking just need 3% of water consumption from total consumption. Furthermore they explained the water consumption breakdown as a percentage of total consumption given Table 1.

Table 23: Water Consumption Breakdown (*Source: Pitt, R. & Clark, S., 2011. P.35*)

Household Activities	Percentage
Baths and showers	34%
Toilet flushing	22 %
Cloth washing	17%
Dish washing	6%

\* Corresponding Author: E-mail - [chandanimalka@gmail.com](mailto:chandanimalka@gmail.com)

<b>Personal hygiene</b>	7%
<b>Other miscellaneous</b>	11%

According to the World Health Organization (WHO) guidelines, the requirements of drinking water need not be the same as that of water required for other purposes. Therefore, rainwater harvesting (RWH) can be used as an alternative resource for non-potable water requirements.

With the growth of the population complexity of livelihood patterns are the contributing factors for increasing water demand. On the other hand, most of the water resources are getting polluted. Therefore, Sri Lanka has a water stress threat in the future. Due to the pollution of raw water, for the treatment process, a large financial investment will be necessary. Instead of using potable water for the non-potable water requirements, it is better to introduce another inexpensive method/ resource to fulfill non-potable water requirements.

By considering all matters mentioned above, RWH can be shown as one of the better alternative methods to meet the non-potable water demand of dwellings.

Therefore, the study was conducted to design a RWH system for typical domestic dwellings for non-potable water requirements in Colombo suburbs.

## 2. LITERATURE REVIEW

Water scarcity is a serious problem throughout the world for both urban & rural communities (Keskar, et al., 2016). One of the biggest challenges of the 21st century is to overcome the growing water shortage. Rainwater harvesting (RWH) has thus regained its importance as a valuable alternative or supplementary water resource, along with more conventional water supply technologies (Worm & Hattum, 2006).

Ariyananda (2010) explained the results of using RWH minimizing the use of treated water for secondary purposes, reduction of flooding, improving soil conservation and groundwater recharge, providing water for domestic use with adequate treatment, agricultural benefits, and reduce energy consumption. Rainwater harvesting technologies are flexible and can be built to meet almost any requirement. Construction, operation, and maintenance are not labour intensive (World Health Organization, 2009)

## 3. METHODOLOGY

The study was carried out in three stages.

Stage 01: Feasibility of rainwater harvesting in domestic dwellings for non-potable water requirements in suburbs in Colombo suburbs was analyzed by secondary data.

Stage 02: Design a rainwater harvesting system for a typical domestic dwelling.

Stage 03: Analyze the financial viability of rainwater harvesting in the Colombo suburbs.

### 3.1 DATA COLLECTION & ANALYSIS METHODS

Rainfall data were collected from the Department of Meteorology from four rainfall stations that are nearest to the Colombo suburbs. To represent Kesbewa, Kaduwela, Maharagama & Homagama successively selected rainfall stations in Bandaragama, Angoda, Dehiwala and Homagama. Although the Kesbewa suburb represents the Bandaragama rainfall station, Bandaragama is in the Kalutara district. Hence, data of Bandaragama rainfall station was not considered for data analysis. Annual rainfall data was gathered for the years 2009-2018. To have more reliable data for the design, outliers of the average monthly rainfall data were removed from the data set.

Monthly water consumptions data were collected from NWS&DB. Here, monthly water consumption of 14 no's houses selected randomly from 211 houses in the Homagama area, for the year 2019. Due to the limitation of the availability of the resources representative sample was thus selected. In addition to that water tariff available for the domestic dwell was used to calculate water bills.

Average monthly consumption of a house and the variance between monthly consumption throughout the year were statically analyzed to prove the reliability of the monthly water demand which is based on the per capita per day water demand calculation.

Water consumption breakdown, runoff coefficient, relative merits of frequently used common tank shapes, cost derived for the production of 1m<sup>3</sup> potable water were obtained from the literature review.

**4. FINDINGS**

**4.1 Most Potential Suburbs**

As per the rainfall data analysis suburbs which contains greater number of highest average monthly rainfall data in the data set, is the most potential area to implement RWH. Therefore, to implement RWH Homagama area was selected. RWH system was designed for the selected area to supplement the non-potable water requirements.

**4.2 Technical Feasibility**

**4.2.1 Shape of the Tank**

In doubly curved tanks stresses are well distributed and the base of the tank is of smaller diameter, reducing both hoop stresses and bending stresses there. Also, the material usage to capacity ratio is very good in the doubly curved tank (Saving up to 20% over a cuboid). But this shape is normally used for a small capacity water tank. Normally it is recommended for RWH range from about 300 liters to 2000 liters as per the Hand Book on Rain Water Harvesting in Storage Options. Therefore for this project doubly curved shaped tank cannot be used. The best tank shape should be select between the cuboid and the cylindrical shapes.

Table 2 illustrates the results of the literature reviewed carried on shapes of cylindrical and cuboid tanks.

Table 2: Relative Merits of Cylindrical and Cuboid Shaped Tanks (Source: Anon., 2001, p.6)

Nos		Cylindrical	Cuboid
1	Surface Area	Cylindrical water tank has the least possible ratio of circumference to surface area than a cuboid water tank that holds the same amount of water. Therefore, a spherical water tank requires less building material than its cuboid shape equivalent and more economical to build.	Water tank has more surface area than a circular-shaped water tank that holds the same amount of water. Therefore, cuboid water require more building materials
2	Stress	Stresses are more evenly distributed with bending stress only near the bottom.	Stresses are unevenly distributed around the structure. Bending stresses are especially high near the edges.
3	Material Usage	There is an improvement in the material used to storage capacity 7.5% over a similarly proportioned cuboid	The ratio between material usage and storage capacity is higher than the cylindrical tank.



Nos		Cylindrical	Cuboid
4	Structural Strength	Cylindrical structure is the strongest geometrical structure and is stronger than cuboid structure, according to Monolithic. Therefore, a cylindrical structure will more successfully withstand the outward-directed force of the water stored within and the force of wind and rain that impinges upon the structure from without.	A rectangular structure is less in strength compared to the cylindrical structure.
5	Constant Heat Level	Round structures minimize surface area through which heat can radiate; they keep the enclosed water at a more constant temperature than boxlike structures. As a result, the water is less affected by ambient temperature fluctuations.	Less resistant to heat and cold.

By considering facts in Table 2 cylindrical shape could be recommended as the most suitable tank shape for the storage tank.

### 4.3 Financial Feasibility

#### 4.3.1 Life Cycle Cost of Storage Tank

Lifecycle costs were calculated for the Reinforced concrete tank, Ferro cement tank and Plastic tank considering the Initial cost of each material, life span of each storage tank, and discount rates of the materials. The initial cost was obtained from BOQ and the span of each material and discount rate was adopted from the literature review.

Life cycle cost of Reinforced concrete tank = Rs 272,829.00

Life cycle cost of Ferro cement tank = Rs 175,550.00

Life cycle cost of Plastic tank = Rs 429,336.37

When comparing the life cycle cost of a Reinforced concrete, Ferro cement and Plastic tanks lowest life cycle cost is showed Ferro cement tank. Therefore, from among the Ferro cement, Plastic, and Reinforced concrete tank, Ferro cement tank installation is more financially feasible.

### 4.4 Environmental Feasibility

Colombo suburbs are being developed so most of the land area is covered by the buildings, roads & impervious material such as interlock paving, etc. Therefore, rain falling on the surface either flood the area or flows away rapidly resulting in very little or no infiltration into the soil. This can be mitigating through RWH. In RWH, excess water can be recharged to the ground. Groundwater recharging (GWR) increase in the exploitable quantity of groundwater and water table of the area has been taken up by the groundwater recharge. GWR also improves the quality of groundwater. In areas where the groundwater contains metals like iron and arsenic and injurious salts like Fluoride, GWR will dilute them and even leech them out.

RWH is useful to retain more water on land and provide an opportunity to grow more trees and maintain biodiversity and recharge groundwater sources. RWH protects the environment.

### 4.5 Cost Benefit Analysis

#### 4.5.1 Capital Recovery Cost

Estimate cost is obtained from the BOQ & cost saving from RWH per year is calculated as following.

$$\begin{aligned} \text{Capital cost recovery} &= \frac{\text{Total Estimate- (Plumbing laying cost for RWH + Roof Plumbing)}}{\text{Saving from RWH per year}} \\ &= \frac{\text{Rs } 307963.00 - (\text{Rs } 39405.00 + \text{Rs } 86100.00)}{\text{Rs } 4613.14} \\ &= 39.55 \\ &= 40 \text{ years} \end{aligned}$$

In the cost analysis, it is seen that the capital cost recovery period of the rainwater harvesting system is greater than the design period, according to the calculation based on the discount rate given to the consumer by NWS&DB.

Although, the capital cost recovery period calculation is based on the cost borne by the consumer, the actual cost incurred for the production is greater than the cost born by the consumer. According to (Gamini & Werellagama, 2012) the production cost of 01 m<sup>3</sup> treated water is equal to three times of billing rate of 01 m<sup>3</sup> treated water. Figure 1 shows the cost derived for the production of 1m<sup>3</sup>potable water.

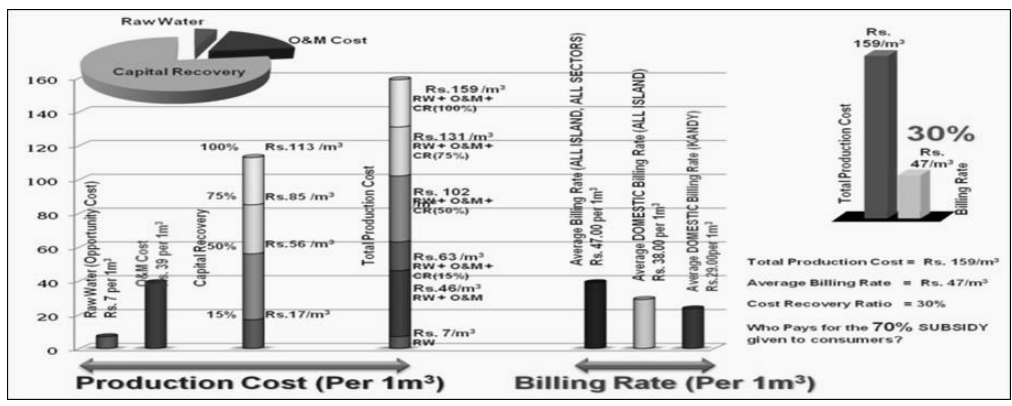

Figure 1 Capital Cost Recovery Component for Different Recovery Ratios, O&M Cost and Present Billing Rate for a Typical Water Supply Scheme (Source: Gamini, S. & Werellagama, D., p.6)

Estimate cost obtained from BOQ and cost saving from RWH per year was calculated as following.

$$\begin{aligned} \text{Capital cost recovery} &= \frac{\text{Total Estimate- (Plumbing laying cost for RWH + Roof Plumbing)}}{\text{Saving from RWH per year}} \\ &= \frac{\text{Rs } 307963.00 - (\text{Rs } 39405.00 + \text{Rs } 86100.00)}{\text{Rs } 20670.00} \\ &= 8.8 \text{ years} \\ &= 9 \text{ years} \end{aligned}$$

Therefore, the calculation based on the actual cost incurred for the production cost of the potable water showed the implementing RWH is cost beneficial. It is seen that the capital cost recovery period is less

than the design period. When considering the scarcity of drinking water and the sustainable concept behind the RWH system more environmental and social benefits can be obtained by this project & that benefits cannot be valued.

#### 4.5.2 Unit Cost of the Storage Tank

The unit cost of the construction tank is inversely proportioned to the size of the tank.

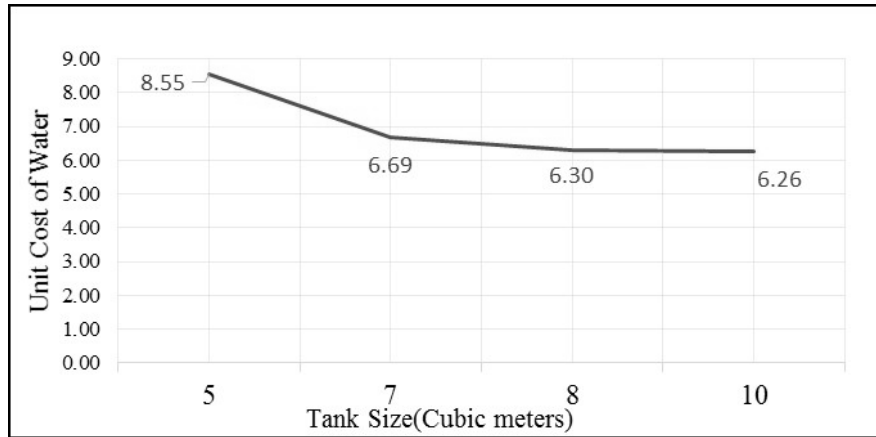

Figure 2: Variation of Unit Cost of Water According to Tank Size (Source: Hapugoda, D. et al., 2009, p)

#### 4.6 Water Quantity

The main aim of the project was to use harvested water to partially fulfill non-potable water requirements to reduce potable water quantity which is consumed for non-potable water requirements. According to the calculation from the implementing RWH, approximately 130 m<sup>3</sup> water quantity can be saved.

$$\begin{aligned}
 \text{Total water demand for a year} &= 20.25 \times 12 \\
 &= 243 \text{ m}^3 \\
 &= 245 \text{ m}^3
 \end{aligned}$$

$$\begin{aligned}
 \text{Saving water quantity through the implementation of RWH} &= \frac{130 \text{ m}^3 \times 100\%}{245 \text{ m}^3} \\
 \text{(As a percentage)} &= 53.06 \%
 \end{aligned}$$

### 5. CONCLUSIONS AND RECOMMENDATIONS

#### 5.1 Conclusions

Rainwater harvesting is mostly available in the dry zone of the country. This project is just concerned about the implementation of RWH in the Colombo suburbs which belong to the wet zone of the country to supplement water consumption. In Colombo suburbs, three suburbs were selected and average monthly rainfall was calculated. From that Homagama area has maximum average rainfall. By using average rainfall data rainfall mass curves were drafted and obtained storage tank capacity. Approximately a water amount of 130 m<sup>3</sup> per typical domestic dwelling can be saved from the RWH. But practical issues occur due to constructing large storage tanks therefore, optimum tank design should be done. Therefore, an optimum storage tank has been designed.

In the feasibility study, it is observed cylindrical shape is most suitable among the Cuboid; Cylindrical & Doubly curved tank shapes. Further, it is observed Ferro cement tank is most suitable as a storage tank among the Concrete, Ferro cement tank and plastic tank from the life cycle cost analysis.

In the cost analysis, it is revealed that the capital cost recovery period of the RWH system is greater than the design period according to the calculation based on the discount rate given to the consumer by NWS&DB. Calculation based on the actual cost incurred for the production cost of the potable water showed the implementing RWH is cost-beneficial, because the capital cost recovery period is less than the design period. However, the cost-benefit analysis for the RWH project is a complex one due to the difficulties of valuing social and environmental benefits incurred to the community.

According to the calculation from the implementing RWH, approximately 130 m<sup>3</sup> water quantity can be saved for a year and as a percentage, it is equal to 53.06% of potable water consumption

Therefore, NWS&DB can be used that potable water which saves through the RWH to cater the fluctuation of water demand which will occur due to population growth, etc. without expanding the water treatment plant.

Several benefits that can be obtained by the RWH project without rainwater drain off to see. Most of them are environmental and social benefits. The main benefit of this project was reducing potable water usage for non-potable water requirements. In addition to that, this is helpful to mitigate flood in the area & additional water can be recharged to the ground hence water table can be increased.

## 5.2 Recommendation

The capital cost recovery analysis which is based on discounted rate showed the cost of the installation of RWH is not recovering during the design period. But as per Figure 2, the unit cost of the construction tank is inversely proportioned to the size of the tank. Therefore NWS&DB can provide a storage tanks for the housing schemes to encourage consumers to use harvested water.

Further, to encourage people to use the RWH system in the houses, responsible local government authorities can request to indicate the percentage of harvested water when applying for the approval of the building plan. In cost of RWH system, a considerable amount of the cost is incurred for constructing the water tank. Therefore reducing the cost of water tanks driven to cost reduction of the RWH system. To reduce the cost of the tank, the required tank capacity can be reduced by using water-efficient appliances and fittings to the RWH system.

## REFERENCES

- Kumar, M. D., Pate, A. & Singh, O. P., n.d. Rainwater Harvesting in the Water-scarce Regions of India.
- Worm, J. & Hattum, T. v., 2006. Rainwater harvesting for domestic use. In: *Agrodok-series No. 43*. Netherlands: ICCO and AID Environment.
- Anon., 2001. *Recommendations For Designing Rainwater Harvesting System Tanks*. s.l.:Development Technology Unit School of Engineering, University of Warwick.
- Anon., 2016. *Guidelines for Residential Rainwater Harvesting Systems*. 1st ed. s.l.:Canada Mortgage and Housing Corporation.
- Anon., 2016. Life cycle analysis of sub-surface brick-dome,rainwater tanks in sri lanka: a comparison with below,ground rcc tanks.
- Anon., 2017. *Manual for Rooftop Rainwater Harvesting Systems*. Republic of Yemen: s.n.
- Anon., 2018. Comparative Estimation Of Underground Water Tank And Elevated Storage Tank of Junnar.
- Anon., Handbook. *Guidelines for Residential Rainwater Harvesting Systems*. Canada: s.n.
- Ariyananda, T., 2001. *Quality of Collected Rainwater from Sri Lanka*. Dhaka, Lanka Rain Water Harvesting Forum.
- Ariyananda, T., 2010. *Domestic Rainwater Harvesting as a Water Supply Option in Sri Lanka*. s.l., s.n.
- Charles, M. J., 2007. rainwater harvesting systems for communities in developing countries.
- De. S Ariyabandu, R., 2001. Household water security using rainwater harvesting. *Domestic Roofwater Harvesting Workshop*, April .
- Gamini, S. & Werellagama, D., 2012. *Investment Cost And Cost Recovery - Water Sector Sri Lanka*, s.l.: s.n.
- Hapugoda, D. et al., 2009. *Rain Water Harvesting,Practitioners Guide For Sri Lanka*. s.l.:Lanka Rainwater Harvesting Forum (LRWHF).

- Hofman, R. et al., 2019. Rainwater Harvesting for Drinking Water Production: A Sustainable and Cost-Effective Solution in. *water*, p. 15.
- Jayasinghe, M. T. R., 2004. Rainwater Harvesting to Supplement Water for Large Housing Projects.
- JeanCharles, M., 2007. *Rainwater Harvesting Systems For Communities In Developing Countries*, Michigan : Michigan Technological University.
- Kumar, D., n.d. Roof Water Harvesting for Domestic Water Security. In: *Roof Water Harvesting for Domestic Water Security*. Gujarat: International Water Resources Association, p. 43–53.
- Kumar, D., Patel, A. & Singh, O., n.d. *Rainwater Harvesting in the Water-scarce Regions of India*. s.l.:s.n.
- Mehrabadia, R. . & Saghafiana, B., 2013. Assessment of residential rainwater harvesting efficiency for meeting.
- Pitt, R. & Clark, S., 2011. *Stormwater Non-Potable Beneficial Uses and Effects on Urban Infrastructure*, s.l.: IWA Publishing.
- Pitt, R., Talebi, L., Bean, R. & Clark, S., 2011. stormwater non-potable beneficial uses and effects on urban infrastructure.
- Rahman, A., Amos, C. C. & Gathenya, J. M., 2016. *Economic Analysis and Feasibility of Rainwater*. Sydney: s.n.
- Saghafian, B. & Fashi, F. H., 2013. Assessment of residential rainwater harvesting efficiency for meeting.
- Weeraratna, C. S. & Ariyananda, T., 2009. Importance of Rainwater Harvesting in Human Health. *14th IRCSA Conference, Kuala Lumpur*, August .
- World Health Organization, M., 2009. *Guidelines and Manual for Rain Water Harvesting in Maldives*. Male: Ministry of Housing Transport and Environment Government of the Republic of Maldives.
- Worm, J. & Hattum, T. v., 2006. *Rainwater harvesting*. 1st ed. s.l.:ICCO and AIDEnvironment.

## **MANAGING CONSTRUCTION PROJECTS FOR BETTER VALUE FOR MONEY**

# Construction Procurement Selection Factors: A Comparative Study on Traditional vs Design and Build Systems

M. P. C. Kuruppu\*, V. Srivishagan, R. Thalpage

Division of Civil Engineering, University College Matara, Sri Lanka

## ABSTRACT

*Procurement system is a process to bring or acquire things and it is opened at the identification of need continues through up to the completion of the contract. Procurement decision largely affects the project performance and experts should select the most reliable procurement system for different construction projects including buildings and civil projects. Multiple categories of building construction projects such as low-rise, medium-rise and high-rise are available in Sri Lanka. However, lack of knowledge in procurement selection is a significant problem in these different projects. Hence, construction specialists should take the responsibility to process the most appropriate procurement systems to fulfill the clients' requirements. Here 100 questionnaires were distributed among construction experts to collect data and 52 responses were received. According to the literature, procurement selection for construction projects should be done by considering various factors including time, cost, client and project characteristics. This research was carried out to determine the appropriate procurement system for multiple types of building projects and road projects in Sri Lankan construction sector by comparing the Traditional and Design and Build procurement method and comparing the affected factors in selecting the most suitable procurement system.*

**Keywords:** Construction, Design and Build, Procurement Selection, Traditional.

## 1. INTRODUCTION

There are various sizes of building projects in Sri Lankan construction industry such as low-rise, medium-rise and high-rise building projects. Moreover, road construction is also an essential requirement of the country development. However, lack of procurement knowledge raises several issues related to the construction projects. Procurement selection are critical requirement to safeguard the effective execution of a specific project relevant with construction industry (Mathonsi & Thwala, 2012). On the other hand, separated (traditional) systems, integrated systems (design and build) and management systems are the different types of procurement systems relevant with construction projects (Osama, 2013).

## 2. LITERATURE REVIEW

In Sri Lanka traditional and design and build systems are highly implemented for the construction projects. Generally, the client's requirement is to be completed the project within lowest cost, high quality and within specified time period. Accordingly, selecting the most suitable procurement system is a very important factor to meet the client's objectives fully. (Ratnasabapathy, et al., 2005). However, lack of construction experience and lack of procurement knowledge and practice are caused to decide the wrong selection of procurement methods, and it may directly destroy the client's expectations. Industry experts shall take the responsibility to achieve expected objectives and prevent client displeasure and failures (Jayasuriya & Rameezdeen, 2010). The major concern of this paper is on determining the most reliable procurement selection for building and road construction by comparative study on traditional system and design and build procurement system. This study has performed by analyzing advantages and disadvantages of these systems and different factors effecting to the procurement selection.

---

\* Corresponding Author: E-mail: [srivisha87@gmail.com](mailto:srivisha87@gmail.com)

## 2.1 Comparative Study on Traditional and Design and Build Procurement Systems

In modern world, alternative procurement solutions are applied to the construction industry than Sri Lanka. Therefore, alternative procurement systems have to be used in local projects (Ratnasabapathy, 2006). Mostly traditional method is applied due to accountability and high price competition. Because in traditional system, competitive bidding process can be identified. Accordingly, bidders are treated equally when proceeding with the bids. In this system, the client's power is higher than the contractor. Further, the client can involve with both design and construction processes. The consultant party is on behalf of the client. The consultant is highly involved with the designing drawings, administration and supervision of the construction process as the client's requirement. Furthermore, the contractor should be taken approvals from the consultant when construction as per the condition of contract. The consultant has highly considered project time, quality and cost (Agha, 2013). There are some disadvantages in traditional procurement systems. The contractor has less power and no authority to join with the design stage. Accordingly, it causes to make problems when constructing the projects (Davis, Love, Baccarini, 2008). The traditional method takes a longer start-up period than alternative systems for design and tendering phases. Here project can be started after completing the design drawings. Also, the client has unlimited authority to make variation of the projects. However, it may be a large impacts on the contractors' work status and project time shedule. Following table 1 has shows the summarization of the traditional procurement methods; advantages and disadvantages.

Table 1: Summarizing the advantages and disadvantages of Traditional procurement system

Advantages	Disadvantages
<b>High price competition. Generally, client has been taken competitive rates</b>	Projects cannot be started at an early stage due to wasting time
<b>Client can directly involve with the project.</b>	Construction work shall start after the design and tender stage (Additional cost for initial phase)
<b>No barriers to the client's side to enter to this method</b>	Contractor has no direct power to take the action due to high Consultant involvement. Further, client's authority is higher than the contractor (contractor's side)
<b>Client has high authority power. Consultant has been highly involvement</b>	Client has authority to make variations (no limitation). Hence, unlimited variations impact on project duration
<b>Ensures the project duration, quality and cost Consultant shall involve with designing, administration and supervision works</b>	No single point responsibility. Client cannot transfer the risk directly to the contractor
<b>Client has been made unlimited variations High accountability. Maintain equal consideration for tenderers. High project quality</b>	High potential for disputes to arise between parties involved

(Sources: Agha O. , 2013; Davis, Love, & Baccarini, 2008)

Design and build method is an integrated system and the contractor has been the solely responsible for design and build activities. Accordingly, the contractor has high authority and directly deal with the client (Masterman, 2008). Moreover, the contractor has chance to share his performance for the design development at the project initial stage. As client-side, project duration can be minimized by maintaining overlaps between design and construction. Accordingly, the overall time duration is minimum than the traditional systems. There is limited power to the client of the project and will incur high costs when the design changes after the commencing project initiation (Agha, 2013). Hence,



variation rates may very high and the client has limited authority to develop the variations. Further, variation document evaluation process is also higher than the traditional method (Ernest, et al., 2017). Therefore, the client should provide his briefs to the design and build contractor clearly. The client incurs losses due to wrong briefs and insufficient information at the early stage (Masterman, 2008). Furthermore, arguments and conflicts are less than the traditional method (Ernest, et al., 2017). However, the client of the project required to inform his briefs through an advisor at the initial stage of the project (Murdoch & Hughes, 2008). Also, limited design and build contractors are available in the industry and it may highly impact on lower grade contractors and new contractors in the industry. Because the design and build contractors should gain high qualifications and experience to take the full responsibility of a project. However, the contractor has to bear the total responsibility of the project. It is a disadvantage on the contractor's side. Generally, design and build contractors' rates are high due to this situation of the industry (Ernest, et al., 2017). The bid evaluation of this method is somewhat difficult, because in this method has been faced various designs and proposals. Following table 2 has been shown the summarization of the Design and Build procurement method.

Table 2: Design and build procurement method: Advantages and Disadvantages

<b>Advantages</b>	<b>Disadvantages</b>
<b>Project construction work can be early started (Both design and construction works can start at the same stage)</b>	Client has high risk about project time quality, cost (due to less consultant involvement)
<b>Direct communication between client and contractor</b>	Limited authority for both client and consultant Limited variations High cost for variations, it has been affected to the client.
<b>Single point responsibility - Contractor has high authority than traditional method. Easy to make decisions so it will be minimizing the time wastage</b>	'Design and build' procurement method contractors' has been limited in the market
<b>Low consultant involvement. Contractor can work freely without any one involvement. Maintain ongoing service</b>	Client shall hire advisor to list down briefs at the initial stage) Additional cost required to appoint advisor. Vague briefs cause to huge losses.
<b>Ensures the project duration, quality and cost Consultant shall involve with designing, administration and supervision works</b>	No single point responsibility. Client cannot transfer the risk directly to the contractor
<b>Client has been made unlimited variations High accountability. Maintain equal consideration for tenderers. High project quality</b>	High potential for disputes to arise between parties involved

(Sources: Ernest, Sidik, & Adamu, 2017; Masterman, 2008)

## 2.2 Factors Affecting to the Procurement Systems

Construction professionals should give their priority for procurement selection factors and possibilities at the early stage (Shiyamini, et al., 1997). As stated by Ogunsanmi (2013), there are various factors that determine the most reliable procurement method for construction projects. Furthermore, according to Mizon, Yin & Yong (2006) and Agha (2013) project time, quality, project type, size, client's familiarity, financial capability, project complexity etc. are greatly impact on procurement selection in construction sector. Generally, traditional procurement systems are selected for the Government construction projects due to high accountability. Time, quality and cost of the project are significant factors in procurement selection (Rosli, 2006). However, there are two elements that have been affected to the effectiveness of the traditional procurement method such as cost overrun and time overrun (Ojo, et al., 2006). Furthermore, procurement selection is connected with four key factors including time, cost, client and Project Characteristics as shown in Table 3. Moreover, time, quality, client' experience, client's financial capability, responsibility, project type, Contractor's knowledge, project location, project size, competition, material availability etc. (Odhigu, 2011). Under time factor, construction experts have to be concerned 3 main sub factors including time control, project completion time and

time for design stage (Agha, 2013). Furthermore, cost of design, consultation payments, and price completion are 3 main sub factors which need to be focused related to the cost impact in the procurement process. There are sub factors as experience of the client, clients trust and financial capacity related with the client factor. As a part of project characteristics, quality level of the project, project type and nature and location of projects can be identified as the main sub factors effecting to the procurement. Further, studies have been developed to study the impact on each sub factor for low-rise, medium-rise, high-rise building projects and roads projects.

Table 3: Key factors impacted to the procurement selection

Main Factor	Sub Factors
<b>Time</b>	1. Time Control 2. Completion Time 3. Minimize Design Time
<b>Cost</b>	1. Cost of The Design 2. Price of Completion 3. Consultant Fee
<b>Client</b>	1. Client's Experience in Procurement Method 2. Client's Financial Capability 3. Client's Trust in Other Party 4. Qualified Procurement Staff availability
<b>Project Characteristics</b>	1. Project Quality Level 2. Project Type/ Nature 3. Project Location

### 3. METHODOLOGY

For data collection, both Qualitative and quantitative approaches shall select as the various approaches used in the researches. However, quantitative approaches shall be applied to evaluate the results relevant with factors effecting to the procurement selection which identified from the above literature review. Literature review shall apply to detect the existing information available relevant to the procurement systems in construction sector. Furthermore, it can be selected to identify the effecting factors for deciding procurement system various construction projects including building and civil works. Accordingly, 100 questionnaires were distributed among local construction professionals to achieve the major objective of this research. At the data analyzing, only 52 numbers of respondents have provided their data and information. Finally, this information was descriptively analyzed with Statistical Packages for the Social Sciences (SPSS) to reach the target of this research.

### 4. RESULTS AND DISCUSSION

Analysis of research is used to analyze the collected data about the affecting factors and sub factors for the procurement system selection. This analysis is used to identify the importance of each factor as high important, medium important and low important. As in table 4, time is highly impact on procurement selection for high rise, mid-rise and road projects. But client and cost factors highly impact on low-rise building projects. Project characteristics are moderately impacted on procurement selection based on the analysis. Further, the cost factor is also highly impact on all the projects. Table 4 shows how main factors impact on the procurement selection based on the respondents.

Table 4: Main factors impact on the procurement selection, respective of the respondent's response

Factor	High-rise Building			Medium-rise Building			Low-rise Building			Road Projects		
	High	Medium	Low	High	Medium	Low	High	Medium	Low	High	Medium	Low
<b>Time</b>	87%	13%	0%	53%	47%	0%	30%	70%	0%	90%	3%	7%
<b>Cost</b>	77%	23%	0%	60%	40%	0%	77%	10%	13%	60%	30%	10%
<b>Client</b>	77%	23%	0%	67%	10%	23%	80%	20%	0%	53%	47%	0%
<b>Project Characteristics</b>	27%	50%	23%	7%	83%	10%	23%	67%	10%	3%	83%	14%

Further, following table 05 show the recommendations of the respondents for selection of procurement for building projects and road projects in Sri Lankan Industry.

Table 5: Recommendations of the respondents for Sri Lankan Construction industry

Type of Project	Traditional Methods	Design and Build Methods	Other Methods
<b>High-rise Building</b>	16.66%	70%	13.33%
<b>Mid-rise Building</b>	43.33%	53.33%	3.33%
<b>Low-rise Building</b>	76.66%	20%	3.33%
<b>Road Project</b>	33.33%	66.66%	0%

As in table 6, time control is also a high important factor when deciding the procurement method for the high-rise building projects. Based on the analysis, design cost is the mostly important sub factor which may affect for the cost. 83% is responded for the design cost. Consultant fee is a moderate important factor which may affect for the cost of the project. When consider the mid-rise building projects, around 90% respondents indicated that time controlling factor is a medium important factor for the time factor. Design cost is not a mostly important sub factor and it is a medium important factor. Price competition, design cost and consultant fee factors are the medium significant factors for selecting a procurement method for the mid-rise building projects. Also, customer financial stability and hope of the other party also are medium important factors for the procurement selection. Project nature and project type is the most important factor when deciding a procurement method for a mid-rise project. Around 73% respondents indicated that time controlling factor is a medium important factor when consider the time factor. Price competition and design cost are low important factors for procurement selection related to low-rise building projects. Time control and completion time are highly impacted on the road projects. Further around 73% respondents indicated that price competition factor under the cost factor is a highest important factor for road projects. Furthermore, project type and nature may highly impact on procurement selection in road projects. Table 6 shows the factors effecting to the selection of procurement systems based on the respondents.

Table 6: Sub Factors effecting to the selection of procurement system for different types of projects

Factors	High-rise Building			Medium-rise Building			Low-rise Building			Road Projects		
	High (H)	Medium (M)	Low (L)	High (H)	Medium (M)	Low (L)	High (L)	Medium (M)	Low (L)	High (H)	Medium (M)	Low (L)
<b>Time</b>												
<b>Time Control</b>	80%	17%	0%	0%	90%	10%	27%	73%	0%	57%	20%	23%
<b>Completion Time</b>	87%	13%	0%	53%	47%	0%	0%	67%	33%	57%	30%	13%
<b>Minimize Design Time</b>	83%	17%	0%	14%	83%	3%	50%	17%	13%	43%	50%	7%
<b>Cost</b>	<b>H</b>	<b>M</b>	<b>L</b>	<b>H</b>	<b>M</b>	<b>L</b>	<b>H</b>	<b>M</b>	<b>L</b>	<b>H</b>	<b>M</b>	<b>L</b>
<b>Price</b>	53%	33%	10%	17%	63%	20%	23%	0%	77%	73%	27%	0%
<b>Completion Design Cost</b>	83%	17%	0%	13%	67%	20%	13%	7%	80%	23%	67%	10%
<b>Consultant Fee</b>	33%	63%	0%	13%	83%	3%	13%	57%	30%	30%	67%	3%
<b>Client</b>	<b>H</b>	<b>M</b>	<b>L</b>	<b>H</b>	<b>M</b>	<b>L</b>	<b>H</b>	<b>M</b>	<b>L</b>	<b>H</b>	<b>M</b>	<b>L</b>
<b>Client's Experience in Procurement Methods</b>	23%	63%	13%	3%	14%	83%	3%	57%	40%	46%	37%	17%
<b>Client's Financial Capability</b>	90%	0%	0%	13%	77%	10%	14%	73%	13%	10%	83%	7%
<b>Client's Trust in Other Party</b>	73%	13%	0%	27%	60%	13%	27%	30%	43%	70%	20%	10%
<b>Project Characteristics</b>	<b>H</b>	<b>M</b>	<b>L</b>	<b>H</b>	<b>M</b>	<b>L</b>	<b>H</b>	<b>M</b>	<b>L</b>	<b>H</b>	<b>M</b>	<b>L</b>
<b>Life Cycle of the Project</b>	23%	76%	0%	40%	30%	30%	27%	60%	13%	40%	33%	27%
<b>Project Type and Nature</b>	80%	20%	0%	77%	17%	6%	50%	40%	10%	67%	20%	13%
<b>Projects Site Location</b>	0%	63%	23%	0%	80%	20%	13%	44%	43%	0%	80%	20%

## 5. CONCLUSION AND RECOMMENDATION

This study is important to identify the procurement systems used in construction sectors in Sri Lanka, also based on the response of the professionals and other experienced employees of various construction projects in Sri Lanka. Accordingly, time is the most critical factor for deciding a procurement systems for high rise building projects, mid-rise building projects and road projects. To overcome this problem, Design and build method should be applied to High rise, mid-rise building projects and road projects. Because when the employer selected the design and build procurement method, professionals can minimize the design time and completion time of the specific projects. Also the design cost and tendering process are not affected to project duration. Based on the table 4, time is medium level factor for procurement section process for low rise building projects. Accordingly the client has enough time to develop the design and tendering process. Further clients' involvement of the project is in high position. Based on table 5, traditional procurement systems should be applied for low-rise building projects. Generally clients for low rise buildings highly consider on aesthetic appearance than time factor. That is due to most of the low-rise buildings are used for the residential purposes. Furthermore, cost and client factors are highly concerned when procurement selection than time factor and project characteristics as table 4. Consultant involvement can be used to reduce the risk relevant to the cost factor. Also, the client has a high power about the project when selecting the traditional procurement method. Further, in low-rise building projects client's requirement is the most important factor for selecting a procurement method. There are considerable changes of each factor which can be seen from the analysis. Accordingly, the professionals should concern the time, cost and other factors before

selecting procurement methods for relevant projects in organizations. Figure 1 shows Procurement selection rankings based on affecting factors on various construction projects.

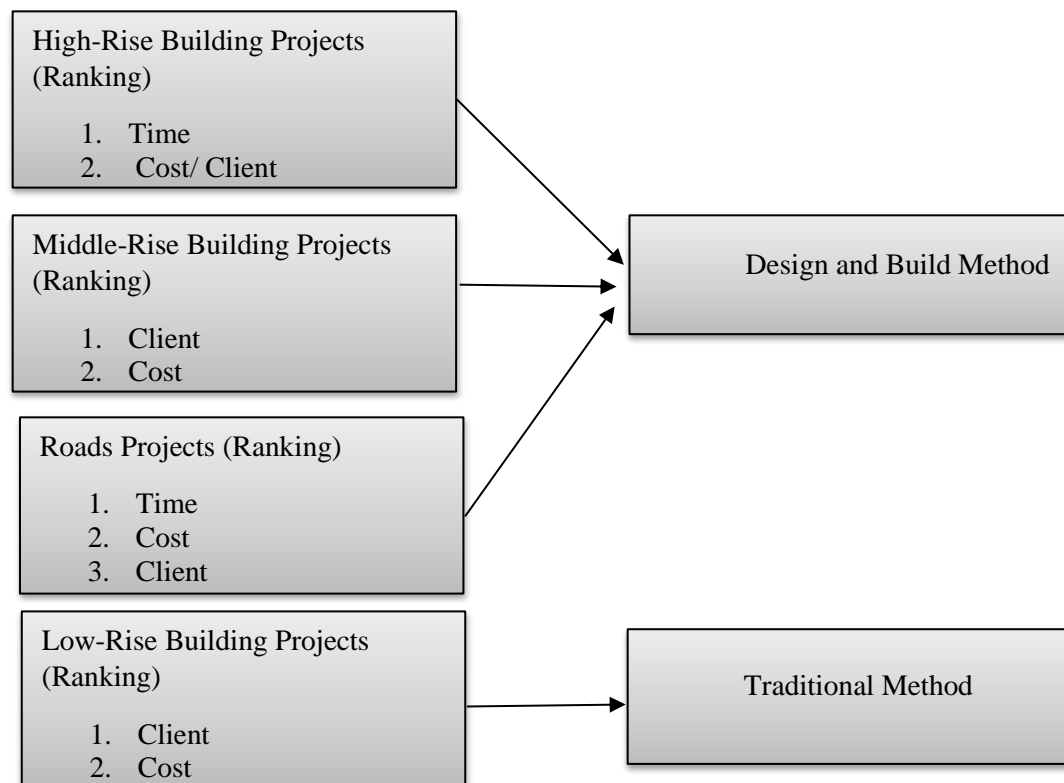

Figure 1: Procurement selection for different projects based on affecting factors

## REFERENCES

- Adamu, I., Mohammed, A.S. and Osei-Tutu, E., (2017). Adopting design and build (D&B) as an alternative construction procurement system to the traditional method in Ghana. *International Journal of Construction Engineering and Management*, 6(4), pp.148-159.
- Agha, O.I.E., (2013). Factors affecting the selection of procurement methods in the construction projects in Gaza Strip.
- Agha, O.I.E., (2013). Factors affecting the selection of procurement methods in the construction projects in Gaza Strip.
- Davis, P., Love, P. & Baccarin, D., (2008). *Building Procurement Methods*, s.l.: s.n Online. [Online] Available at: [http:// www.construction-innovation.info/ images/pdfs/ Research\\_library/ ResearchLibraryC/ 2006-034-C/reports/Report\\_-\\_Building\\_Procurement\\_Methods.pdf](http://www.construction-innovation.info/images/pdfs/Research_library/ResearchLibraryC/2006-034-C/reports/Report_-_Building_Procurement_Methods.pdf).
- Hashim, M., Chan, M.Y.L., Ng, C.Y. et al. (2006). Factors influencing the selection of procurement systems by clients.
- Hughes, W., Hillebrandt, P. and Murdoch, J., (2000). The impact of contract duration on the cost of cash retention. *Construction management & economics*, 18(1), pp.11-14.
- Jayasuriya, S. and Rameezdeen, R., (2010). Construction Procurement Selection: Comparative Study of Routine Projects vs. Disaster Reconstruction Projects. In *International conference on building resilience: Interdisciplinary approaches to disaster risk reduction, and the development of sustainable communities and cities, At Kandalama, Sri Lanka*.
- Mathonsi, M.D. and Thwala, W.D., (2012). Factors influencing the selection of procurement systems in the South African construction industry. *African Journal of Business Management*, 6(10), p.3583.
- Ogunsanmi, O., (2013). Effects of procurement related factors on construction project performance in

- Ojo, S.O., Fagbenle, O.I. and Adeyemi, A.Y., (2006). The performance of traditional contract procurement on housing projects in Nigeria. *Civil Engineering Dimension*, 8(2), pp.81-86.
- Rameezdeen, R., Rathnasabapathi, S. and Amaratunga, R.D.G., (2005). Macro analysis of construction procurement trends in Sri Lanka.
- Rashid, R.A., Mustapa, M. and Wahid, S.N.A., 2006, June. Bills of Quantities-Are they still useful and relevant today. In *International conference on construction industry*.
- Ratnasabapathy, S. and Rameezdeen, R., (2010). A decision support system for the selection of best procurement system in construction. *Built-Environment Sri Lanka*, 7(2).
- Ratnasabapathy, S., (2006). Study of Factors Affecting the Selection of Procurement Systems -j in Construction Industry: A Multi-Criteria Decision Support Model. p. xi.

# Employee Satisfaction with the Intrinsic and Extrinsic Motivation Factors in Sri Lankan Construction Industry

I.H.P.R. Indikatiya\*, N.S. Karunasinghe, M.N. Dilhani, T.D. Weerasekera

Division of Civil Engineering, University College of Matara, Sri Lanka

## ABSTRACT

*Enhancing the employee productivity through effective employee motivation in the construction industry has become a global requirement due to its rapid development. Therefore, this study is determined the degree of employee satisfaction with the intrinsic and extrinsic motivation factors in the Sri Lankan construction industry in order to enhance employee productivity. The findings of the questionnaire survey based on a quantitative research approach revealed that the employees who took part in the survey were not satisfied with all intrinsic and extrinsic motivation factors provided to them. The study also discloses that the employees in the Sri Lankan construction industry were more dissatisfied with the extrinsic motivation factors than intrinsic motivation factors provided to them. Eventually, the study highlighted that the significant relationship between employee satisfaction with the intrinsic and extrinsic motivation factors and enhancing employee productivity in the Sri Lankan construction industry.*

**Keywords:** Construction industry, Employee productivity, Employee motivation, Employee satisfaction.

## 1. INTRODUCTION

Enhancing the productivity of the construction industry has become a global requirement (Bawa, 2017). Employee motivation is an influencing factor in enhancing the productivity of the construction industry (Jarkas, et al., 2014). There are a lot of employee motivational factors like career advancement, work conditions, monetary incentives, job content, work safety, and social affairs, so on which determined in the construction industry in order to enhance employee productivity (Hamza, et al., 2017; Kappia, et al., 2007). The authors further stated that, employee productivity depends directly on the employee motivation factors they enjoy. Pinder (1998) defines motivation as inputs that initiate and maintain expected and acceptable work behaviors to achieve organisational goals. Employee motivation can be carried out mainly in two ways known as intrinsic motivation and extrinsic motivation (Chalam, 2017; Marzuki, et al., 2012; Kappia, et al., 2007).

Bawa (2017) has highlighted the role of employee motivation factors in construction organizations if the organizations wish to enhance maximum employee productivity. With complex nature of the Sri Lankan construction industry, the employees in the Sri Lankan construction industry expect different types of motivation factors from their employers based on both intrinsic and extrinsic motivation (Illangakoon, et al., 2020). Nevertheless, only a few Sri Lankan construction organizations provide adequate employee motivation factors to their employees (Halwatura, 2015; Illangakoon, et al., 2020). This kind of situation often creates employee dissatisfaction with the intrinsic and extrinsic motivation factors, and it may results in poor employee productivity in the Sri Lankan construction industry. Therefore, employee satisfaction through the intrinsic and extrinsic motivation factors in the Sri Lankan construction industry has to be considered a significant factor when enhance maximum employee productivity (Illangakoon, et al., 2020). Sri Lankan construction industry has so far not focused on determining the level of employee satisfaction with the intrinsic and extrinsic motivation factors provided to them to enhance maximum employee productivity. The past studies have figured out the significance of intrinsic and extrinsic motivation aspects in the construction industry. However, there have been no past studies carried out to decide the degree of employee satisfaction in terms of intrinsic

---

\* Corresponding author: E mail - [pabasararavindu94@gmail.com](mailto:pabasararavindu94@gmail.com)

and extrinsic motivation factors in the Sri Lankan construction industry made available to them. Therefore, this study was carried out to fulfill this industry need and literature gap. Accordingly, the objective of this study was to identify employee satisfaction with both the intrinsic and extrinsic motivation factors available to them in the Sri Lankan construction industry.

## **2. LITERATURE REVIEW**

### **2.1. Overview of the Construction Industry in Sri Lanka**

Sri Lankan construction industry provides a considerable contribution in increasing its national income (Liyanage, et al., 2019). Basically, the Sri Lankan construction industry consists of two main types of projects, namely residential projects and non-residential projects (Gosselin, et al., 2016). The authors further stated that residential projects refer to construction and renovations related to single homes and multi-family homes, whereas non-residential projects refer to construction and renovations related to commercial or industrial facilities (Gosselin, et al., 2016). In addition to that, the construction industry consists of different projects related to infrastructure facilities such as roads, bridges, and water projects, so on (Safa, et al., 2015).

During the post-war period, the construction industry has been rapidly developed due to high investments for construction projects in Sri Lanka (Thalpawila, 2016). The Sri Lankan construction industry has taken approximately 9% of GDP within total GDP in the last decade (Department of census and statistics, Ministry of finance, economy and policy development, 2020). Uphold above stated that, the rapid development of the Sri Lankan construction industry has been highly directed to develop national and social factors in the Sri Lankan economy such as employment, infrastructure facilities urbanization, etc. Furthermore, the Sri Lankan construction industry has been considered as one of the primary sources of employment due to higher labor intensity in the sector (Halwatura, 2015). However, the Covid-19 pandemic situation has been adversely impacted on Sri Lankan construction industry output, and it was directed to reduce employment in the construction industry also (Pathirana, 2020).

### **2.2. Employee Productivity**

Different terms refer to define employee productivity in the construction industry based on performance factors, unit individual hour per rate, and etc. (Jarkas, 2015). Typically, it can be characterized as the proportion among output and input, as the ratio of input of associated resources in the construction industry to actual output in the construction industry (Dozzi & AbouRizk, 1993). Especially, employee productivity in the construction industry is measured by considering physical progress achieved (Hamza, et al., 2017). As per Dozzi and AbouRizk (1993), two most important measures of productivity are the adequacy with which work is utilized in the construction cycle and the general productivity of work doing what it is needed to do at a given overall setting.

However, the complex nature of the construction industry makes it challenging to enhance employee productivity continuously (Halwatura, 2015; Illangakoon, et al., 2020). Many researchers have investigated employee productivity in the construction industry and determined different consequences of poor employee productivity (Hamza, et al., 2017). The construction delays with respect to the poor productivity of construction employees are a prevalent consequence in developing countries (Halwatura, 2015). Nevertheless, various factors in the construction industry have been recognized by various researches to enhance employee productivity. According to the model developed by Christen, Iyer, and Soberman (2006), there is an immediate connection between employee satisfaction and employee productivity. Therefore, employee satisfaction on different factors is crucial to enhance employee productivity in the construction industry.



### 2.3. Employee Satisfaction

Employee satisfaction is presented as set of negative and positive feelings of employees about their job roles (Singh & Jain, 2013) and it is based of different factors such as rewards, supervision, peers, subordinates, their working environment, and so on (George & Jones, 2008). It is a significant influential factor to the efficiency and effectiveness of employees in any industry, the especially construction industry as labor-intensive industry (Shaju & Subhashini, 2017). Employee dissatisfaction can create different negative consequences in the construction industry, like loss of loyalty, expanded absenteeism and, expanded number of mishaps, etc. (Aziri, 2011). Ultimately, all these negative consequences lead to poor employee productivity in the construction industry.

Among the factors that affect to enhance employee satisfaction in the construction industry, employee motivation factors are significant (Illangakoon, et al., 2020). Compelling employee motivation will satisfy employees in the construction industry to enhance maximum employee productivity (Halwatura, 2015). An effective relationship between employee satisfaction and employee motivation also improves the financial performance of organizations in the construction industry (Shaju & Subhashini, 2017). Therefore, employers in the construction industry will have to provide effective motivation factors to satisfy employees in order to enhance the maximum productivity of employees in the construction industry.

### 2.4. Employee Motivation Factors

The word "motivation" comes from the Latin word "movere," which meaning "to move" (Ruthankoon & Ogunlana, 2003). Motivation has a key role in maintaining the competitiveness and survival of the business in a particular industry (Cardoso, et al., 2015). Hollyforde & Whiddett (2002) define motivation as the driving force behind human behavior. Ololube (2005) stated that "*Motivation is an internal arousal that guides and sustains the achievement of a specific objective.*" . Therefore, motivation can be considered as an influencing force to achieve organizational goals by enhancing employee productivity (Bańka, 2016).

Motivation has been described considering two main aspects as intrinsic and extrinsic (Chalam, 2017; Deckers, 2018). Intrinsic motivation deals with the inner feelings of the employees and how they feel about their job (Parkin, et al., 2009). Further, intrinsic motivation is deemed to be better as the motivation it creates comes from within the person (Cho & Perry, 2012). The authors further stated that these intrinsic factors allow individuals to grow and develop their careers. However, the effectiveness of those factors depends on the perception of the particular person (Deckers, 2018). Management cannot rely entirely on intrinsic variables to affect employee productivity (Kassa, 2015). It is better to use extrinsic and intrinsic motivation strategies to retain employees effectively (Deckers, 2018). Extrinsic motivation is the motivation that allows employees to act in a particular way due to the influence of external (Chalam, 2017). Extrinsic rewards can be described under few categories as direct compensation given periodically by the company as financial rewards including salary or pay, bonus and other incentives (Hamza, et al., 2017). Although, extrinsic motivation can be provided as indirect compensation in insurance, leave, and other facilities (Kassa, 2015). Apart from the above two categories, extrinsic motivation can be given as non-financial compensation such as career advancement and improving working conditions (Marzuki, et al., 2012). Some past studies argued that intrinsic motivation is better and more effective than extrinsic motivation. However, extrinsic and intrinsic motivation factors have considerable significance in enhancing employee productivity in the construction industry (Deckers, 2018). Table 1 demonstrates the types of motivation factors of these intrinsic motivations and extrinsic motivations.

Table 1: Intrinsic and extrinsic motivation factors

Intrinsic Motivation Factors	Extrinsic Motivation Factors
Career Growth or Advancement	Supervision
Job Responsibility	Salary
Achievements in Career Life	Working Conditions
Recognition for Achievements	Interpersonal Relationships
Working Life	Job Status
	Organizational Policy & Administration
	Job Security

Sources: (Hamza, et al., 2017; Illangakoon, et al., 2020; Jarkas, et al., 2014; Kappia, et al., 2007; Parkin, et al., 2009)

Five intrinsic motivation factors affect employee productivity, whereas seven extrinsic motivation factors affect employee productivity based on literature findings. In the construction industry, good employee motivation factors will improve job satisfaction, relationships with co-workers, retention of employees, and especially employee productivity (Jarkas, et al., 2014). Therefore, organizations in the construction industry should provide proper employee motivation factors to enhance the maximum employee productivity in the industry (Jarkas, 2015).

### 3. RESEARCH METHODOLOGY

Creswell (2003) stated that the quantitative research approach could be used in studies where the research question begins with the word “What”. Therefore, the quantitative research approach has been adapted to carry out the data collection of this study through a questionnaire survey conducted among administrative employees occupying in leading Sri Lankan construction organizations. The questionnaire used in the survey was used to define the employees’ degree of satisfaction through both the intrinsic and extrinsic motivation factors available to them in Sri Lankan construction industry. Hundred administrative employees were selected using the convenience sampling method. Fifty employees responded to the questionnaires by ranking their satisfaction level on both the intrinsic and extrinsic motivation factors using a 1-5 Likert scale. Therefore, this study’s findings are applicable only to improve the level of satisfaction of the administrative employees with both the intrinsic and extrinsic motivation factors available to them in the Sri Lankan construction industry. The level of employee satisfaction with overall motivational factors available to employees in the Sri Lankan construction industry was measured using the following formula:

$$\text{Level of employee satisfaction with overall motivational factors} = \frac{\sum Wxn}{A_{xn}} \times 100\% \quad (\text{Eq: 01})$$

Where,

W: Constant expressing the weighting given to each response

A: The highest weighting

n: The frequency of responses

N: Total number in the responses

Employee satisfaction on each intrinsic and extrinsic motivation factor was measured using the t-test given in the Statistical Package for Social Sciences (SPSS) Software. The formula used is as follows:

$$t = \frac{\bar{X} - \mu}{\frac{s}{\sqrt{N}}} \quad (\text{Eq: 02})$$

Where,

$\bar{X}$  bar: The sample mean,

$\mu$ : The population mean,

s: The sample variance

n: The sample size.

$\mu$  was taken as 3 since in the definition given in the 5 points Likert scale used in the questionnaire survey, rankings below 3 indicated dissatisfaction, and rankings above 3 indicated satisfaction.

## 4. RESEARCH FINDINGS AND DISCUSSION

### 4.1. Level of Employee Satisfaction with Overall Motivational Factors

The number of responses received based on employee satisfaction with overall motivation factors in the Sri Lankan construction industry presents in table 2.

Table 2: Number of respondents satisfied with overall motivation factors

Level of satisfaction	Number of respondents	percentage
Not Satisfied	10	20.0%
Somewhat Satisfied	13	26.0%
Satisfied	27	54.0%
Very Satisfied	0	0.0%
Extremely Satisfied	0	0.0%

The level of employee satisfaction with overall motivational factors available to them in the Sri Lankan construction industry was measured using the following formula:

$$\begin{aligned} \text{Level of employee satisfaction with overall motivational factors} &= \frac{\sum Wxn}{A_{xn}} \times 100\% \\ &= \left( \frac{(27*3) + (13*2) + (10*1)}{(50*5)} \right) \times 100\% \\ &= 46.8\% \end{aligned}$$

According to the level of employee satisfaction with overall motivational factors in the Sri Lankan construction industry, only 46.8% of employees were satisfied with existing motivation factors. It states, more than half of employees were dissatisfied with motivation factors in the Sri Lankan construction industry. It might result in decreased employee productivity in the Sri Lankan construction industry. As per the literature findings on employee motivation factors, employee satisfaction and employee productivity in the Sri Lankan construction industry were highly directed with each factor.

### 4.2. Employee Satisfaction with the Intrinsic Motivation Factors

Five main motivation factors are determined based on the intrinsic employee motivation in the Sri Lankan construction industry, namely career growth or advancement, job responsibility, career achievements, recognition for achievements, and working life. Table 3 shows the employee satisfaction

level with each of these intrinsic motivation factors in the Sri Lankan construction industry, as results from t-test by using SPSS software.

Table 3: Employee satisfaction level with intrinsic motivation factors

<b>One-Sample Test</b>				
<b>Test Value = 3</b>				
<b>Factors</b>	<b>t-value</b>	<b>Rank</b>	<b>Sig.(2-tailed)</b>	<b>Mean</b>
<b>Career Growth or Advancement</b>	-6.933	3	0.000	2.3912
<b>Job Responsibility</b>	-7.129	4	0.000	2.3708
<b>Achievements in Career Life</b>	-6.589	2	0.000	2.4281
<b>Recognition for Achievements</b>	-7.324	5	0.000	2.3319
<b>Working Life</b>	-6.109	1	0.000	2.7025

Employees in the Sri Lankan construction industry were not satisfied with any intrinsic motivation factors available to them in the industry. Because of t-values of all factors were resulted as negative values, whereas mean values resulted in less than 3.0. Therefore, it has caused more than half of dissatisfied employees with overall motivational factors. Nevertheless, working life was the intrinsic motivation factor with which employees were most satisfied among five intrinsic motivation factors.

#### 4.3. Employee Satisfaction with the Extrinsic Motivation Factors

Seven main motivation factors are determined based on the extrinsic employee motivation in the Sri Lankan construction industry, namely supervision, salary, working condition, interpersonal relationships, job status, organizational policy, and administration and job security. Table 4 shows the employee satisfaction level with each of these extrinsic motivation factors in the Sri Lankan construction industry, as results from t-test by using SPSS software.

Table 4: Employee satisfaction with extrinsic motivation factors

<b>One-Sample Test</b>				
<b>Test Value = 3</b>				
<b>Factors</b>	<b>t-value</b>	<b>Rank</b>	<b>Sig.(2-tailed)</b>	<b>Mean</b>
<b>Supervision</b>	-10.844	7	.000	2.2697
<b>Salary</b>	-8.362	6	.000	2.3933
<b>Working Conditions</b>	-6.033	4	.000	2.4382
<b>Interpersonal Relationships</b>	-5.129	1	.000	2.6404
<b>Job Status</b>	-6.589	2	.000	2.5281
<b>Organizational Policy &amp; Administration</b>	-6.024	3	.000	2.4719
<b>Job Security</b>	-7.209	5	.000	2.4045

Any of the extrinsic motivation factors have not been provided as expected by the employees in the Sri Lankan construction industry. Because of t-values of all factors resulted as negative values, whereas mean values resulted in less than 3.0. Interpersonal relationships were the extrinsic motivation factor

with which employees were most satisfied, while salary and supervision were the extrinsic motivation factors with which employees were most dissatisfied.

Furthermore, the Sri Lankan construction industry employees were more dissatisfied with extrinsic motivation factors than intrinsic motivation factors when comparing the results of the t-test on employee satisfaction with employee motivation factors in the industry. Therefore, employee satisfaction with extrinsic motivation factors is highly directed to enhance the employee productivity in the Sri Lankan construction industry.

## 5. CONCLUSIONS AND RECOMMENDATIONS

The construction industry is significant in achieving financial-economic balance in Sri Lanka. It provides a wide range of outcomes to the economy, from individual residences to large-scale buildings and infrastructure facilities such as highways, power plants, railway lines, petrochemical complexes, etc. The feat of the construction industry bases on the employees due to its high labor intensity. Therefore, employee motivation in the construction industry has a direct relationship with its productivity. The study revealed that there are two kinds of motivation factors in Sri Lankan construction industry such as intrinsic and extrinsic motivation factors. As per the research findings, the Sri Lankan construction industry employees were not satisfied with all intrinsic and extrinsic motivation factors provided to them. Furthermore, the employees in Sri Lankan construction industry were more dissatisfied with extrinsic motivation factors than intrinsic motivation factors provided to them. Therefore, the management of Sri Lankan construction organizations can focus on achieving the expected level of employee satisfaction with the employee motivational factors through the findings of this study by adopting suitable strategies. Furthermore, the study findings provide valuable policy implications for the government and the management of Sri Lankan construction organizations in improving the employee productivity of the construction industry. The findings also provide a valuable roadmap to improve existing motivational factors in the Sri Lankan construction industry, especially extrinsic motivation factors. However, the study findings are limited to administrative employees who work in Sri Lankan construction organizations.

## REFERENCES

- Aziri, B., 2011. Job Satisfaction: A literature review. *Management Research and Practice*, 3(4), pp. 77-86.
- Bańka, A., 2016. The driving force of action and the psychology of doing nothing. *Polish Journal of Applied Psychology*, 14(2), pp. 9-46.
- Bawa, M. A., 2017. Employee motivation and productivity: A review of literature and implications for management practices. *International Journal of Economics, Commerce and Management*, V(12), pp. 662-673.
- Cardoso, P., Dominguez, C. & Paiva, A., 2015. Hints to improve motivation in construction companies. *Procedia Computer Science*, Volume 64, p. *Procedia Computer Science*.
- Chalam, V. V., 2017. Motivation, definitions, and classification. *Adaptive Control Systems*, pp. 1-28.
- Cho, Y. J. & Perry, J. L., 2012. Intrinsic Motivation and Employee Attitudes Role of Managerial Trustworthiness, Goal Directedness, and Extrinsic Reward Expectancy. *Review of Public Personnel Administration*, XX(X), pp. 1-25.
- Deckers, L., 2018. Extrinsic and intrinsic motivation. *Motivation*, pp. 307-340.
- Department of census and statistics, Ministry of finance, economy and policy development, 2020. *National Accounts of Sri Lanka*, Colombo: Ministry of finance, economy and policy development.
- Dozzi, S. P. & AbouRizk, S. M., 1993. *Productivity in construction*. s.l.:National Research Council Canada.
- George, J. & Jones, J., 2008. *Understanding and Managing Organizational Behavior (5th Edition)*. New Jersey: Pearson/Prentice Hall.
- Gosselin, A., Blanchet, P., Lehoux, N. & Cimon, Y., 2016. Main motivations and barriers for using wood in multi-story and non-residential construction projects. *Bio Resources*, 12(1), pp. 546-570.

- Halwatura, R. U., 2015. Critical factors which govern labour productivity in building construction industry in Sri Lanka. *PM World Journal*, IV(IV), pp. 1-13.
- Hamza, M. M. et al., 2017. Identifying motivational and Demotivational factors in Qatar construction project management practices. s.l., s.n., pp. 34-40.
- Hollyforde, S. & Whiddett, S., 2002. *The motivation handbook*. s.l.:CIPD Publishing.
- Illangakoon, M. A. N., Mel, V. D. R. D. & Kathriarachchi, T. C., 2020. Construction workers motivation and skill development: A strategy for improving construction productivity in Sri Lanka. s.l., General Sir John Kotelawala Defence University.
- Jarkas, A. M., 2015. Factors influencing labour productivity in Bahrain's construction industry. *International Journal of Construction Management*, 15(1), pp. 94-108.
- Jarkas, A. M., Radosavljevic, M. & Wuyi, L., 2014. Prominent demotivational factors influencing the productivity of construction project managers in Qatar. *International Journal of Productivity and Performance Management*, 63(8), pp. 1070-1090.
- Kappia, J., Dainty, A. & Price, A., 2007. Prioritising career development in relation to recruitment and retention: A trade and craft perspective. *Construction Management and Economics*, 25(3), pp. 239-253.
- Kassa, T., 2015. Employee Motivation and its Effect on Employee Retention in Ambo Mineral Water Factory. *International Journal of Advance Research in Computer Science and Management Studies*, 3(3), pp. 10-21.
- Liyanage, K. L. K. A. T., Waidyasekara, K. G. A. S., Mallawaarachchi, B. H. & Pandithawatta, T. P. W. S. I., 2019. Origins of construction and demolition waste generation in the Sri Lankan construction industry. s.l., s.n., pp. 1-8.
- Marzuki, H., Permadi, I. & Sunaryo, P., 2012. Factors affecting job satisfaction of workers in Indonesian Construction Companies. *Journal of Civil Engineering and Management*, 18(3), pp. 299-309.
- Ololube, N., 2005. Benchmarking the Motivational Competencies of Academically Qualified Teachers and Professionally Qualified Teachers in Nigerian Secondary Schools. s.l., s.n.
- Parkin, A., Tutesigensi, A. & Büyükalp, A., 2009. Motivation among Construction Workers in Turkey. Nottingham, s.n., pp. 105-114.
- Pathirana, L. P. D. S., 2020. Effect of COVID -19 and strategic response: A review on Sri Lankan construction industry. *International Journal of Economics and Management Studies*, 7(6), pp. 73-77.
- Pinder, G., 1998. *Work motivation in organisational behaviour*. London: Prentice Hall.
- Ruthankoon, R. & Ogunlana, S. O., 2003. Testing Herzberg's two-factor theory in the Thai construction industry. *Engineering, Construction and Architectural Management*, 10(5), pp. 333-341.
- Safa, M. et al., 2015. Classification of construction projects. *International Journal of Civil, Environmental, Structural, Construction and Architectural Engineering*, 9(6), pp. 625-633.
- Shaju, M. & Subhashini, D., 2017. A study on the impact of job satisfaction on job performance of employees working in automobile industry, Punjab, India. *Journal of Management Research*, 9(1), p. 117.
- Singh, J. & Jain, M., 2013. A study of employees' job satisfaction and its impact on their performance. *Journal of Indian Research*, 1(4), pp. 105-111.
- Thalpawila, O. N., 2016. Post –War reconstruction in Sri Lanka: Reconstruction and development of the socio-economic sectors. *International Journal of Liberal Arts and Social Science*, 4(5), pp. 43-56.

# Energy Benchmark Analysis of Supermarkets

Chamila Sumathiratna<sup>\*1</sup>, D.D. D. Suraweera<sup>2</sup>, Anusha Wijewardane<sup>3</sup>

<sup>1</sup>Department of Building Services Technology, University of Vocational Technology, Sri Lanka

<sup>2</sup>Department of Electrical and Electronics Technology, University of Vocational Technology, Sri Lanka

<sup>3</sup>Department of Mechanical Engineering, University of Moratuwa, Sri Lanka

## ABSTRACT

*Urbanization, living styles practices of people and so many other factors have increased energy consumption drastically in the recent past. Now it has come to a critical stage and may lead to crisis. It is a known fact that a building consumes energy but supermarkets consume a lot of energy compared to other commercial buildings. Due to the busy lifestyles of people, the turnover of supermarkets amplified and so is the number of shops. Different countries in the world have supermarkets of different scales but the most common factor of them in tropical countries is the energy consumption for air conditioning. This dominates and accounts for around 40% of the total energy of the building. The situation in Sri Lanka may not be different but studies published in that area are very limited. Almost every supermarket in Sri Lanka depends on the grid power supply. Increasing the number of supermarkets in par with the demand of the people, increase the load on the national grid. It is worthwhile to quantify the energy used by supermarkets owned by different chains in Sri Lanka and rate them accordingly. Based on the specific energy consumption or energy use intensity (EUI) of supermarket buildings, benchmarking could be achieved. This could be used to rate supermarkets on energy consumption provide them some incentives to push them to adopt practices that contribute to energy efficiency which is of national importance.*

**Keywords:** *Benchmarking, Modelling, Specific Energy Consumption, Supermarket.*

## 1. INTRODUCTION

The evaluation and benchmarking of energy consumption are seen as an indispensable component in the energy management of the building. A good benchmarking system may help identify the ranking of the building and avenues for improving energy efficiency and cost savings. It needs to be addressed by the policies of a country and benefited by both the public and private sectors. A good rating system can increase profits for owners of the supermarket and eventually benefit goes to the customers. This paper discusses the energy consumption of supermarkets in different countries highlighting the necessity of such a system in Sri Lanka. This paper attempts to review body of literature related to energy consumption and Energy Use Intensity (EUI) of supermarkets in other countries with the objective of facilitating to propose energy benchmarking in supermarkets of Sri Lanka. Literature related to energy consumption of supermarkets was researched where snowballing techniques were used to locate literature. Results of this review are to find out values of Energy Use Intensities (EUI) which is a measure of energy efficiency of different supermarkets across the world.

The supermarket sector in the industry in Sri Lanka has shown massive growth in parallel showing the essence of the western lifestyle in Sri Lanka during the past decade in Figure 1. New supermarket developments could be seen in areas including Kandy, Galle, Anuradhapura, Kurunegala, and Matara, etc. in par with the development of the network of roads. Where convenience is the key benefit sought by people. Looking at the evolution of modern supply chains, catalysts for the persistent increased demand for supermarkets may be value-added consumer products such as fast food, processed food, organic food items, discounted & promotional items, etc.

---

\* Corresponding Author: E-mail - [chamilas@uovt.ac.lk](mailto:chamilas@uovt.ac.lk)

Sri Lanka has six popular supermarket chains out of which three having highest number of outlets scattered in urban cities, especially in Colombo and suburbs. The graph in Fig.1 shows a rapid increase of outlets from year 2018 to year 2020.

The working crowd used to do shopping on their way home. Generally these supermarkets have largest traffic from late evening until the closing time. The highest peak in maximum demand curve of our power system (from 7.30pm -8.30pm) falls within the time duration the supermarkets get highest traffic. Therefore the supermarket share of energy consumption positively contributes to the uplift of the maximum demand curve during peak hours. During this period power system has to produce electricity using non renewable energy sources like petroleum. The thermal power generation has contributed 55% in 2018 & 65% in 2019 to the system. (CEB Report) Therefore it is important benchmark energy consumption of these buildings and optimization is significant to the economy and environment of the country. It was found in literature study that energy consumed by supermarkets are high in other countries. As an example Curakao the Energy Use Intensity for supermarkets is vary from 434 kWh/m<sup>2</sup>.yr to 747 kWh/m<sup>2</sup>.yr. Curakao is a country has a similar climate to our country. Unfortunately it is hard to find research studies done in depth, for Sri Lanka of this area facilitating to quantify the energy consumption of supermarkets. Energy consumption patterns of supermarket buildings cannot be compared with other commercial buildings as the energy consumption depends on factors like number of customers, the duration they are keeping open the cooling cabinets, opening hours, amount of food the temperature needs to maintained, area of fenestration, the sun path etc. A detailed research study will be carried out following the literature study, to formulate a range of benchmarking values for supermarkets in Sri Lanka facilitating to compare energy efficiencies within same chain and among different chains of supermarkets.

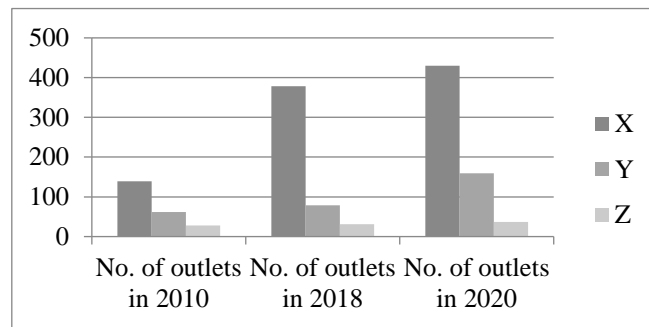

Figure 1: Increase in number of outlets of supermarkets in different chains (Vidanapathirana, 2011, p.36, Fitch rating 2017, p.07)

## 2. ENERGY USE OF SUPERMARKETS OF DIFFERENT COUNTRIES

Energy Use Intensity values for super markets in different countries were studied.

### 2.1. Building Energy Benchmarking in Singapore

Every year energy benchmark study is done and results are published through a report since 2013 in Singapore. Making the information transparent is a valuable concept in this sector. The competitiveness among the business entities made this kind of information secret. But transparency in this scenario is of national importance and the government could intervene to get rid of this bottleneck. Initialized benchmarking in 2013 and throughout, it was continuing. There are three types of buildings commercial buildings comprising office buildings, hotels, retail buildings, and mixed developments, healthcare facilities and educational institutions, large buildings of civic, community, and cultural institutions, sports and recreation centers, and transport facilities (BCA, 2014). Hotels and supermarkets fall under the commercial category. The highest energy consumption is reported from this category but a reduction is shown in energy consumption in 2020. Average values of Energy Use Intensities (EUI). The table below shows the Intensities of Buildings of Singapore which the values are improving.



Table 1: Specific Energy Use for Different Sectors of Singapore Buildings  
(Building Construction Authority - Singapore, 2019, p.07)

Sector	2020 (kWh/m <sup>2</sup> ·yr)	2019 (kWh/m <sup>2</sup> ·yr)	2018 (kWh/m <sup>2</sup> ·yr)
Commercial (including supermarkets)	260.84	271.52	276.26
Health Care Facilities	292.3	299	267.72
Educational Institutes	220.97	230.93	229.76
Cultural Institutes	116.36	155.55	115.71
Recreation centers	172.22	201.66	201.81

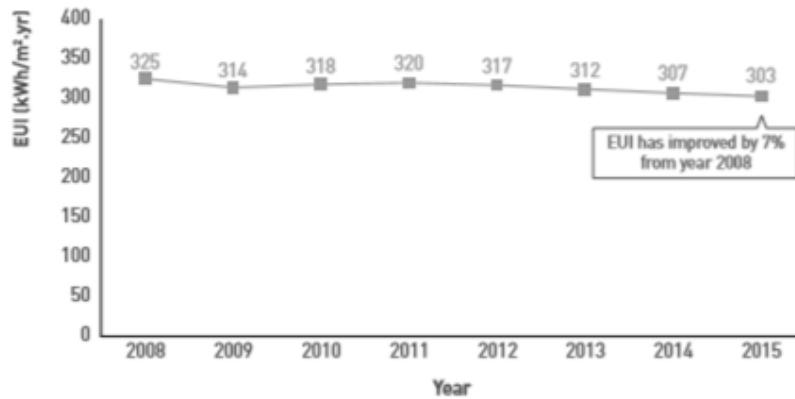

Figure 2: Specific energy use for Commercial Buildings (Including Supermarkets) of Singapore buildings  
(Building Energy Benchmarking Report Singapore, 2018, p.7)

It is evident that the values of the Energy Use Index are reducing with time. The study comprised 947 buildings. The facilities of these are of common types like air conditioning. The quartile values of the population help to identify benchmarking values. One of the reasons for poor energy efficiency is aged air conditioning equipment like chillers (BCA, 2016). The study comprised 947 buildings. The facilities of these are of common types like air conditioning. The quartile values of the population help to identify benchmarking values. Further studies have been carried out to find out the reasons for the large power consumption. It has been found out that the old types of installed air conditioning equipment are one of the reasons for the high values received by the study (BCA, 2020).

**2.2. Energy Benchmark for Commercial Buildings in India**

Table 2. Specific Energy Consumption of Supermarkets in India (Bureau of Energy Efficiency, 2015, p.02)

Climate Zones of India	Energy Utilization Index (kWh/m <sup>2</sup> ·yr) (kWh/m <sup>2</sup> ·yr)
Warm & Humid	428
Composite	327
Hot & Dry	273
Moderate	257

India is the second large country among the selected. It has climatic variations across the country. Therefore, the buildings have been divided into four depending on the climate zones namely Warm & Humid, Composite, Hot and Dry, and Moderate. The energy use intensities of supermarkets and office buildings are shown in Table.2. The values are relatively high for supermarket buildings compared with commercial buildings. Data collection has been performed such that it represents all the climate groups. (India, 2012)

### 2.3 Assessing the Energy Use of Supermarkets and Shopping Malls in Curacao

Curacao (12.1696° N, 68.9900° W) is a country situated above Brazil approximately the same distance from the equator to Sri Lanka (7.8731° N, 80.7718° E). The island of Curacao is located in the southern part of the Caribbean Sea. The climate in Curacao is semi-arid and tropical, that is a small amount of precipitation and temperatures that are relatively constant around 31 °C throughout the year. (Marugg, 2016). The main energy supply of this country is fossil fuel imported from other countries. Hence energy saving is more important. Table 3 shows EUI. Energy benchmarking has been done by linear regression model and found the normalized Energy Use Intensities (EUI) also normalized with cooling degree days. The figure shows how the specific energy values vary monthly.

Table 3: Energy Use Intensities of supermarkets in Curacao per annum (Marugg, 2016, p.30)

Name of Supermarket	Specific Energy Use kWh/m <sup>2</sup> .yr
1	576
2	747
3	618
4	618
5	434
6	552
7	642
8	582

### 2.4 Energy Benchmarking in Supermarkets in Gulf Coastal Region

The Gulf climate is known to be hot and arid. In this particular study, eight supermarkets were studied and the values of Energy Use Intensities were normalized according to the floor area, climatic factors, building age & occupancy rate. The study has been carried out in Ajman, Bahrain, Dubai, Oman & Sharjah (Juaidi, 2015). The values of Energy Use Intensities are in Table 4. Even though they are normalized there is a considerable variation among the values that may be due to energy wastage which has not been accounted for normalization.

Table 4: Energy Benchmarking in Supermarkets in Gulf Coastal Region (Juaidi, 2016, p.06)

Supermarket/Country	Energy Use Intensity kWh/m <sup>2</sup> .yr
Ajman,	2467
Bahrain	748
Dubai 1	1288
Dubai 2	538
Dubai 3	998
Oman 1	1177
Oman2	1393
Sharjah	1454

## 2.5 Energy Performance Targets for Supermarkets in United States

Energy consumption in supermarkets in the United States (US) is estimated to be 4% of the national electricity use (Arias, 2005). In the US, supermarkets have a very large area compared to other countries. Average supermarkets with approximately 3700-5600m<sup>2</sup> of sales area consume about 2-3 million kWh annually for total store energy use (Arias, 2005). The national average Energy Use Intensities (EUI) of a grocery store in the US is between (1942 kJ/m<sup>2</sup> per year to 3282 kJ/m<sup>2</sup> per year). United States has sixteen detailed climate zones according to ASHRAE. These climate zones are broadly categorized into three zones, namely Moist Zone indicated by A, Dry Zone indicated by B, and Marine Zone indicated by C. But there are differences of values under the main categories among detailed climatic zones. The Energy Use Intensities are normalized according to the climate in different zones and areas of the supermarket etc. facilitating comparison across different zones in the United States. (Sharp, 2015.)

Table 5: Energy Use Intensities of Supermarkets of United States (Sharp, 2012, p.09)

Climate Zone According to ASHRAE	EUI	
	(kBtu/ ft <sup>2</sup> /yr)	(kJ/m <sup>2</sup> /yr)
1A (moist)	171	1942
2A (moist)	182	2067
3A (moist)	185	2101
4A (moist)	199	2260
5A (moist)	211	2396
6A (moist)	226	2567
2B (dry)	172	1953
3B (dry)	166	1885
3B (dry)	172	1953
4B (dry)	182	2067
5B (dry)	195	2215
6B (dry)	214	2430
3C (marine)	180	2044
4C (marine)	196	2226
7	241	2737
8	289	3282

## 2.6 Energy Benchmarking in Supermarkets of Japan

Table 6: Energy Use Intensities of Supermarkets of Japan (Yamaguchi, 2012, p.08)

Type of Supermarket	Average Energy Use Intensity [kWh/ m <sup>2</sup> .yr]
Department store	925
Food supermarket	1850
Convenience-store	4219

Japan has four islands namely Hokkaido, Honshu, Shikoku and Kyushu. Data have been taken to cover the range of islands in different categories of retail shops including supermarkets. The purpose of the store is clearly mentioned so that the shop could be identified with the function, as different countries use different names for supermarkets. The values of food supermarkets were taken into consideration as it is more similar to the supermarkets in Sri Lanka. The food supermarkets are categorized as sales of food and beverage exceeds 70% (Yamaguchi, 2012). Energy Use Intensity of a few other supermarket types in Japan is also included in Table 6.

## 2.7 The Situation of Sri Lanka

For the different sectors in the country, energy benchmarking has been set by the Sustainable Energy Authority of Sri Lanka (SEASL). The sectors are the Commercial Buildings, Tea industry, Clothing industry, and Hotel industry, but not conducted a survey for the Supermarkets which is a fast growing in commercial sector. The benchmarking values for the above-mentioned sectors have been revised from 2012 to 2013. If the industry's indicator for the said industries is greater than the benchmark value, the industry can further improve its practices (SEASL, 2016). If the industry's indicator is lesser than the benchmark value then it is operating with good practices. From the year 2012 to year, 2013 total number of 27 industries were subjected to the study in the above-mentioned sectors but after that unfortunately it has not been continued.

## 3. FINDINGS AND DISCUSSION

According to the articles reviewed, many countries have developed systems in benchmarking the energy performance of supermarkets. Energy Use Intensity values enable to compare energy efficiency of different buildings. Also monitoring EUI values for long period like several years, facilitates taking decisions regarding energy management of the building. Unfortunately, there is no properly established system of energy benchmarking performed yearly in Sri Lanka other than initiatives taken by the Sustainable Energy Authority of Sri Lanka only for some sectors. In the industry like commercial, tea, apparel, and hotel. But the number of buildings used for the study is not sufficient to generalize the result for the whole country.

Energy Use Intensity values vary due to climatic factors, floor area of the supermarket etc. The value of Energy Use Intensity vary between the minimum of 100kWh/m<sup>2</sup>.yr to maximum of 4000kWh/m<sup>2</sup>.yr in the review across different countries...

## 4. CONCLUSIONS & RECOMMENDATIONS

After an intensive study on the energy consumption of supermarkets, a considerable research gap is identified a rating scale is yet to be introduced to categorize the supermarkets in Sri Lanka in terms of energy utilization, which is benchmarked with international best practices. However, it is not possible to adopt available benchmark internationally as energy consumption depends on multiple factors such as climatic and seasonal variations, level of development, culture and shopping habits etc.

Energy management culture needs to be inculcated in the supermarket sector giving emphasis to the energy performance of supermarkets and motivate them to reduce energy consumptions which improve profit margins while obtaining a competitive advantage. This needs to be a collective effort with supermarket management, researchers, employers, manufacturers, energy labeling institutions, supplies and energy consultants, etc. (Arias, 2005).

The data collected for research studies need to be maintained in a repository accessible to required authorized parties as such data is useful to conduct research studies that contribute to the level of policy decisions in the country.

## REFERENCES

- Arias, J., 2005. *Energy Use in Supermarkets and Field Measurements*, s.l.: s.n.  
 BCA, 2014. *Building Energy Benchmarking Report*, s.l.: Building Construction Authority Singapore.  
 BCA, 2015. *Building Energy Benchmarking Report*, s.l.: Building Construction Authority Singapore.  
 BCA, 2016. *Building Energy Benchmarking Report*, s.l.: Building Construction Authority Singapore.  
 BCA, 2017. *Building Energy Benchmark Report*, s.l.: Building Construction Authority Singapore.  
 BCA, 2018. *Building Energy Benchmarking Report*, s.l.: Building Construction Authority Singapore.  
 BCA, 2019. *Building Energy Benchmarking Report*, s.l.: Building Construction Authority Singapore.  
 BCA, 2020. *Building Energy Benchmarking Report*, s.l.: Building Construction Authority Singapore.  
 CEB, 2018. *Annual Report*, s.l.: CEB.

- DailyNews, 2020. *2020 and Beyond Trends Shaping Supermarkets Future*. [Online] Available at: <https://www.dailynews.lk/2020/07/08/finance/222626/2020-and-beyond-trends-shaping-supermarkets-future-retrospective-view-past> [Accessed 05 May 2021].
- Foster.A, E., 2018. *Benchmarking of Supermarket Energy Consumption UK*. Beijing, s.n.
- Hewage, 2016. *Impact of internal and external factors in building energy consumption in Sri Lanka*, Moratuwa: University of Moratuwa.
- Holdings, J. K., 2018. *Review of 3rd quarter*, s.l.: Jhon Keels Holdings.
- India, B. o. E., 2012. *Energy Benchmarks for Commercial Buildings*, Newdelhi: Energy Benchmarks for Commercial Buildings.
- Juaidi, A., n.d. *Energy benchmarking for shopping centers in Gulf Coast region*, s.l.: s.n.
- Lanka, S. R., 2020. *Survey Research Lanka*. [Online] Available at: <https://srl.lk/> [Accessed 05 09 2021].
- Marugg, C., 2016. *Assessing the Energy Use of Supermarkets and Shopping Moles in Curakao*, s.l.: s.n.
- Puram.R.K., 2017. *Energy benchmarks for Commercial Buildings India Under UNDP Project*. [Online] Available at: [www.beenet.in](http://www.beenet.in) [Accessed 05 05 2021].
- Report, F. R., 2017. *Fitch rating*, s.l.: s.n.
- SEASL, 2016. *Energy Consumption Benchmark Analysis by Sustainable Energy Authority of Sri Lanka*, Colombo: Sustainable Energy Authority of Sri Lanka.
- Sharp, T., 2015. *Developing Building Energy Performance Targets for ASHRAE Standard 100*, Tennessee: Oak Ridge National Laboratory.
- Sharp, T., n.d. *Developing Building Energy Performance Targets For ASHRAE Standard 100*, tennessee: Oak Ridge National Laboratory.
- Tassou, 2010. Energy Consumption And Conservation In Food. *Applied Thermal Engineering, Elsevier*, Volume 31, p. 147.
- Traill.W.B, 2006. *The Rapid Rise of Supermarkets*, Malden: Blackwell Publishing.
- Wickremasinghe,H.T., 2018. *Review of Trends in Mixed Use of Sky Scrapers in Sri Lanka*. Colombo, Science Direct.
- Wongsapai.W, 2019. *Investigation on The Energy Consumption of Department Store in Thailand*. s.l., s.n.
- Yamaguchi, Y., 2012. *Classification of Japanese Retail Facilities to Establish Benchmark Energy Consumption*, s.l.: s.n.

# Examining the Exclusive Nature of Construction Claims during the Covid-19 Outbreak

Chandana Jayalath, Asitha Kanchana\*

Department of Quantity Surveying, University of Vocational Technology, Sri Lanka

## ABSTRACT

*It seems that there is no end in sight to the far-reaching impacts of the COVID-19 virus. Claims will continue to stem from suspension of work as a result of mandatory quarantine and curfew, and inevitable material shortages due to the disruption of worldwide manufacturing, distribution and supply chains. The findings of a pilot study of the types, causes, and frequency of construction claims in the Sri Lankan construction industry are presented in this study employing a questionnaire survey conducted between the months of January and March 2021. The data received from this survey were represented by Contractors, Consultants, and Design Engineering and Quantity Surveying firms. 67 responses were analyzed using weighted average and importance index in order to understand the exclusive nature of the 'COVID-19 specific construction claims' in terms of their frequencies and magnitude. Recommendations were made to prevent or at least reduce the number of claims in construction projects. It was found that loss of productivity has been frequent in almost every instance since the prevalence of COVID-19 which was followed by 'Force Majeure' claims and 'Time Extension' claims. It is anticipated that the outcomes of this study will aid construction firms to proactively cope with the main causes of claims and, reduce delays and cost overruns in construction projects.*

**Keywords:** Claims, Construction industry, COVID-19, Delays.

## 1. INTRODUCTION

The Novel Coronavirus (COVID-19) pandemic continues to pose significant impacts on firms in the construction supply chain. Unlike ever in history, construction projects today are a source of more claims mainly due to the pervasive impacts of the recurrent outbreaks of COVID-19. Ho & Liu (2004) mentions that it is frustrating the number of claims within the construction industry continue to rise. The timing, impact, and the contributing effect of each of those causes to the net delay should be ascertained in helping the parties settle faster (Vidogah & Ndekugri, 1997). Contractors expect the impacts of the COVID-19 pandemic on their projects until few years to come. Across the globe, where the vaccination of groups is slower, the pandemic could exert impacts on construction projects for even longer periods of time. As a consequence thereof, besides lockdowns, the projects are impacted severely by increased safety measures, site distancing and the limitations of the number of individuals permitted on site at a time and border restrictions. It is likely that the emergence of new variants of the virus, such as 'Delta variant', may result in lengthy restrictions in the future. Albeit some of Covid-related delays have been basically time extension claims, they have been settled in most of the times as no other option is possible. Construction Practitioners still lack real clarity on how these claims will be dealt with, as they are first time occurring. Relatively in event of its short period, the 'COVID-19 related claims' have been topical and perhaps unique, to some extent. The goal of this paper is to identify this uniqueness in terms of type, frequency and remedial measures.

## 2. LITERATURE REVIEW

Due to the impact on building materials in manufacturing sector and transportation sector, such as long lead times for delivery of construction materials, a severe impact on supply chains is visible (AIQS, 2020). Construction Contractors work remotely where unavoidable and it posed a number of challenges to site operations and employment. The long-term economic consequences of COVID-19 is

---

\* Corresponding Author: E-mail - [asithakanchana@live.com](mailto:asithakanchana@live.com)

unprecedented (Pravir, 2020). The cement and dry mortar good distribution and retail have been restricted island wide owing to the imposition of lockdowns and curfews (Economy next 2020). The completion dates have been postponed. Hence, suppliers find themselves in a predicament as the operating costs are increasing consequent to the increases of the expenditure related to special hygienic facilities (Economy next, 2020). As per the guidelines of Epidemiology Unit - Ministry of Health - Sri Lanka, Contractors ought to provide hand hygiene facilities, face masks, and other personal protective equipment (PPEs) if required at the site. This may result in an additional cost. In Sri Lanka, a number of large-scale building projects have slowed down owing to the imposition of curfews and procurement delays of materials from China. As many construction projects in Sri Lanka are undertaken by Chinese Contractors, lockdowns in China also substantially affected the industry in Sri Lanka (PWC, 2020). As a consequence thereof, megaprojects in the public sector have temporarily been suspended (Economy next, 2020).

It is commonplace for a Contractor to charge for additional preliminaries based on the duration that a project has been extended. This sort of claim is referred to as a 'pro rata prelims claim' (Dean, 2011). Savini, (2020) contends that loss of productivity, disruption and suspension of works are the types of claims found in the context of COVID-19. The disruption claims are inevitable during the COVID-19 crisis, mainly because of out of sequence working, restricted or piecemeal site access, and late provision of instructions (Anthony and Sian, 2020). Whilst some workers are ill or trapped in closed down territories and unable to report to work, others are not keen to report to work for fear of contracting the infection. Nicholas (2020) insists that time extension claims are appropriate under the circumstances as the parties can be excused easily with a couple of resolution such as site lockdown to the extent where possible insurance mechanism to ease out the financial constraints and planning for resuming work once the effects have subsided. Alsharif et al., (2021) in their study on COVID-19 impacts on construction emphasized that delay, disruption and price escalation claims are inevitable due to substantial delays on projects, difficulty obtaining materials on time, material price escalations, and many other reasons such as requiring to wear face masks, maintain social distancing, provide COVID-19-related training, administering temperature checks etc. Christian et al., (2021) find that imposition of shutdown of construction sites, restriction on movement by government and the introduction of new standard operating procedures may necessarily warrant proper claims management process while following-up quarantine procedures.

Among the remedies available, claims for the cost of the decreased productivity of the employees and other costs incurred prepared on the basis of area, activity, or period are ideal (Pravir, 2020). However, the analysis of the various causes that contribute to a project's delay is central to resolving it (Christian, 2021). To-date, there is literature on the impacts of COVID-19 on the construction supply chain scattered in the domain of construction research however, its specific nature, type and frequency of claims as well as mitigatory measures have not been researched adequately in the domestic construction sector. The aim of this paper is to fill up this vacuum of comprehension in the construction related claims during the COVID-19 crisis.

### **3. RESEARCH METHODOLOGY**

A quantitative data collection approach was adopted due to the fact that many people are stuck in lockdown and restricted areas. First, qualitative measures were set up by extensive literature review on construction claims during Covid-19. The established measures were then included in the questionnaire which was administered among Contractors and Consultants in Sri Lanka registered for construction contracting and construction consultancy services. Employing different statistical methods, the obtained responses could be summarized, averaged and analyzed which is ensured by Five-point Likert scale (Nunnally & Bernstein, 2007). The questionnaire mailed to one hundred firms during March 2021 had four main sections: 1. about the firm; 2. Types of claims and connected frequency; 3. causes of such claims and their frequencies; 4. remedial measures. Responses were obtained from 67 leading firms (52 building and Civil Contractors and 15 Design Offices and Engineering Consultants whose Head Offices have been located in Colombo suburbs). The respondents have taken part in a wide array of small to large-size projects during their business tenure. Data were analyzed using Weighted Average

and Importance Index emphasizing varying degrees of importance and ranking of factors obtained in a Likert scale.

**4. FINDINGS AND DISCUSSION**

The profile of firms participated in the survey demonstrated Fig 1. The type of firm represents the small Contractors, medium scale Contractors, large scale Contractors, Design Firms, Engineering Firms and Quantity Surveying Firms who have participated in the survey and the percentage represented in the survey is given in Series 1. As per CIDA registration criteria, Contractors that belong to grade C6 through C9 were considered small Contractors, C5 through C3 were considered medium scale Contractors, while C2 through CS2 were considered large scale Contractors.

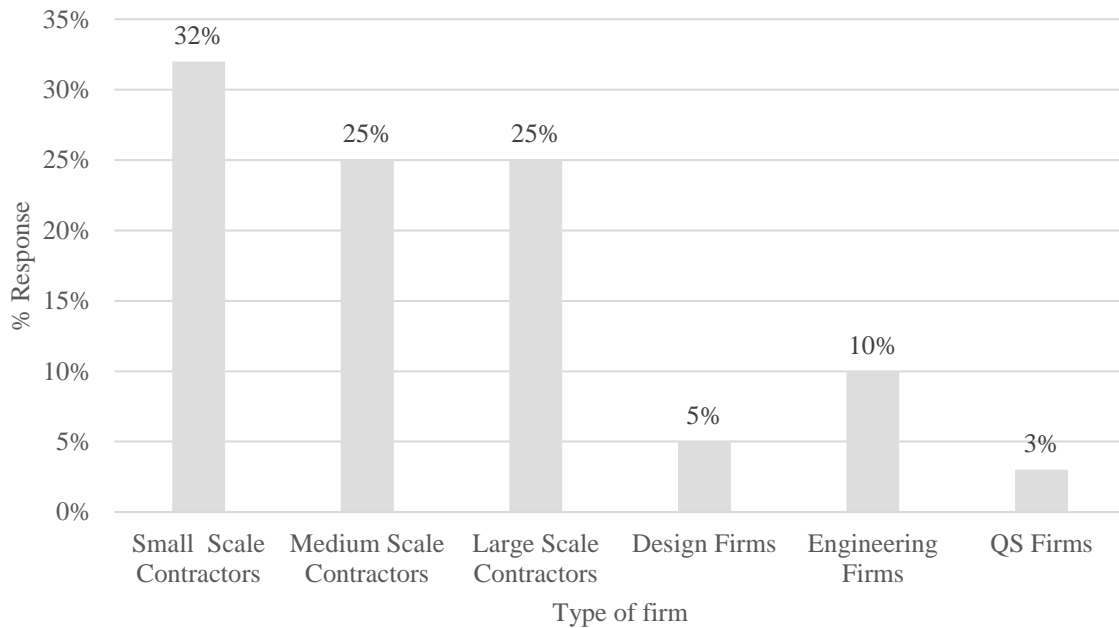

Figure 1: Profile of Respondents

**4.1 Types of Claims and connected Frequency**

Participants were requested to assign the frequency of each type of claims: on a scale from 0 to 4 for each of the five frequencies with a weight of 0 for "never, 1 for "rare", 2 for "average", 3 for "frequent" and 4 for "very frequent". The frequencies for each type of claims are given in Table 1.

Table 1: Frequencies of Claims

Types of Claims	No Response	Never	Rare	Average	Frequent	Very Frequent
Loss of Profit	8	16	25	13	5	0
Time extension claims	5	9	15	17	18	3
Acceleration Claims	4	15	20	15	9	4
Loss of Productivity	0	2	7	29	19	10
Force Majeure	1	2	10	20	24	10
Suspension Claims	0	12	25	23	6	1
Damage Claims	4	20	20	13	8	2
Disruption Claims	2	9	24	14	12	6

As indicated below in Table 2, employing the formula below, a "Weighted Average" was calculated for each sort of claims;



$$\text{Weighted Average} = \text{Where: } W_i \times X_i / N \quad (\text{Eq: 01})$$

where,

- i            The number of options (from 1 for "never" to 5 for "very frequent")
- $W_i$         The weight allocated to the 1<sup>st</sup> option;
- $X_i$         The number of respondents who selected the 1<sup>st</sup> option; and
- N            The total number of respondents (67 in this study).

An "Importance Index" percentage was then calculated for each type of claims as follows (Table 2):

$$\text{Importance Index} = \text{Weighted Average} * 100 / 4 \quad (\text{Eq: 02})$$

Table 2: Ranking of Types of Claims

Types of Claims	Weighted Average	Importance Index (%)	Rank
Loss of productivity	2.48	62.0%	1
Force majeure	2.46	61.5%	2
Time extension	2.00	50.0%	3
Disruption	1.54	38.5%	4
Different site condition claims	1.46	36.5%	5
Acceleration claims	1.39	34.8%	6
Damage claims	1.14	28.5%	7
Loss of profit	1.07	26.8%	8

#### 4.2 Causes of Claims and Connected Frequency

In this section, a table with 27 possible causes of claims was provided. Similar to the types of claims, participants were requested to select one of five possible options for the frequency of each cause of claims: never, rare, average, frequent, and very frequent with a weight for each on a scale from 0 to 4. Data were analyzed and a weighted average and importance index were calculated using equation (1) and equation (2) for each cause of claims. See Table 3 below.

Table 3: Ranking of Causes of Claims

Causes of Claims	Weighted Average	Importance Index (%)	Rank
Extended site preliminaries	2.05	51.3%	1
Delay caused by owner	2.00	50.0%	2
Shortage of materials	1.95	48.8%	3
Delay in payments by owner	1.82	45.5%	4
Low price of contract due to high competition	1.80	45.0%	5
Changes in material & labor costs	1.68	42.0%	6
Compliance with quarantine regulations	1.63	40.8%	7
Variations in quantities	1.61	40.3%	8
Subcontracting problems	1.57	39.3%	9
Delay in long lead item supply	1.55	38.8%	10

<b>Change in sequence of work</b>	1.55	38.8%	10
<b>Contractor financial problems</b>	1.55	38.8%	10
<b>Idling plant and equipment</b>	1.50	37.5%	13
<b>Government announcements and restrictions</b>	1.38	34.5%	14
<b>Variations</b>	1.32	33.0%	15
<b>Loss due to curfew imposed from time to time</b>	1.32	33.0%	15
<b>Design errors or omissions</b>	1.29	32.3%	17
<b>Reduced labour to avoid site congestion</b>	1.25	31.3%	18
<b>Substitution of materials</b>	1.25	31.3%	18
<b>Additional onsite and warehouse protective measures</b>	1.21	30.3%	20
<b>Specifications &amp; drawings inconsistencies</b>	1.14	28.5%	21
<b>Termination of work</b>	1.14	28.5%	21
<b>Additional costs on plant maintenance</b>	1.05	26.3%	23
<b>Suspension of work</b>	1.05	26.3%	23
<b>Additional demurrages paid on transit of materials, plant and equipment</b>	1.02	25.5%	25
<b>Omitted works</b>	1.00	25.0%	26

### 4.3 Remedial Measures to Reduce Impacts

In this section, a table was provided with 12 possible remedial measures. Similar to the types of claims, participants selected options and data received from respondents were analyzed using equation (1) and equation (2).

Table 4: Ranking of the Remedial Measures

<b>Remedial measures</b>	<b>Weighted Average</b>	<b>Importance (%)</b>	<b>Index</b>	<b>Rank</b>
<b>Changing sequence of work</b>	2.05	51.3%		1
<b>Deployment of labor in small crews</b>	2.00	50.0%		2
<b>Implementing double shifts</b>	1.95	48.8%		3
<b>Work home arrangements</b>	1.82	45.5%		4
<b>Online arrangements</b>	1.80	45.0%		5
<b>Focus on domestic construction methods</b>	1.68	42.0%		6
<b>Use of local building materials</b>	1.63	40.8%		7
<b>Promoting site assembly than in situ operations</b>	1.61	40.3%		8
<b>Site distancing</b>	1.57	39.3%		9
<b>Taking protective measures(materials/plant/tools)</b>	1.55	38.8%		10
<b>Amicable settlement of commercial issues</b>	1.55	38.8%		10
<b>Site level negotiation</b>	1.00	38.8%		10

Employers are to comprehend how, they will deal with new types of claims in construction projects due to Covid 19. It is clear that loss of productivity and force majeure claims have been topical during COVID-19 period. While ranking, a more clarity was achieved. Among the causes of claims, the extended site preliminaries are phenomenal in the current context of COVID-19. Shortage of materials due to reduced production at factory level has several ripple effects such as being unable to deliver as contracted and additional costs on plant maintenance. Lockdowns have several ramifications both direct and indirect such as impact on transportation and logistics, additional demurrages paid on transit of materials, plant and equipment, surge in prices of raw materials etc. The focus transferred to attenuating delays and costs when the immediate impacts of the COVID-19 crisis on contracts have been figured. A lot has been said about the need for survival strategies through the pandemic.

## 5. CONCLUSION

COVID-19 is exceptional. It is however no longer excusable for non-taking remedial actions where appropriate. It is important that these issues are addressed contemporaneously. Necessary measures should be adopted to elucidate any issues that can potentially arise in these problem areas. To summarize, it was found that extended preliminaries, delays caused by Owner and shortage of materials have become trivial. As a result, the majority suggest some kind of change in the sequence of planned work, deployment of labour in small crews yet in double shifts where possible. Loss of productivity has been frequent in almost every instance since the prevalence of COVID-19 which is followed by 'Force Majeure' claims. Therefore; it is recommended that consideration be drawn to contract clauses dealing with change (variation) orders, disputes, variations and extra work conditions, and delay. The reduction or avoiding them altogether is by far the best means to cope with risk of construction claims. It is expected that the findings of this research will assist all parties to avoid the main causes of claims and, minimize delays and cost overruns.

## REFERENCES

- AIQS (2020) *Post COVID19 - Construction Management in Sri Lanka* [Webinar], Australian Institute of Quantity Surveyors.
- Alsharef A, Banerjee S, Uddin S.M.J, Albert A, Jaselskis E (2021) *Early Impacts of the COVID-19 Pandemic on the United States Construction Industry*. Int. J. Environ. Res. Public Health 2021, 18, 1559.
- Anthony B and Sian H (2020), Coronavirus: disruption claims in construction, Outlaw Gудie, Pinsent Masons.
- Christian F.A, Ito E.U, Monday O (2021) A Conceptual Framework for Managing Construction Claims in the Face of the COVID-19 Pandemic in Nigeria, *International Journal of Real Estate Studies* © 2020 Penerbit UTM Press.
- Dean Oleary (2011) United Arab Emirates: Construction Claims: Recovering the Costs Of Additional Preliminaries, Mondaq.
- Economy next (2020) "Sri Lanka Listed Companies Hit by Coronavirus, some Firms Resume Works," Economy next, Available at: <https://economynext.com/sri-lanka-listed-companies-hit-by-coronavirus-some-firms-resume-work-69689/> [Accessed 15 January 2021].
- Field A. (2013) *Discovering statistics using IBM SPSS statistics*. 4th ed. London: SAGE.
- Ho S.P, Liu L.Y (2004) Analytical model for analyzing construction claims and opportunistic bidding. *Journal of Construction Engineering and Management*, 130 (1), 94-104.
- Nicholas G, 2020, *Actions for Covid-19 on your construction project*, Fenick Elliot Okafor, O. P.
- Nunnally J.C, Bernstein I.H (2007) *Psychometric theory*. 3rd ed. New York: McGraw-Hill.
- Pravir S (2020) How will COVID-19 affect the future of Real Estate in Sri Lanka? PwC "COVID-19: *What it means for engineering and construction*," PwC, 2020. Available at: <https://www.pwc.com/us/en/library/covid-19/coronavirus-impacts-engineering-construction.html>, [Accessed 15 January 2021].
- PwC (2020) "COVID-19: *What it means for engineering and construction*," Available at: <https://www.pwc.com/us/en/library/covid-19/coronavirus-impacts-engineering-construction.html>, [Accessed 15 January 2021].
- Savini P (2020) *The Effects Of The Corona Pandemic On Construction Contracts*, Nithya Partners.
- Vidogah W, Ndekugri I (1997) Improving management of claims: contractors' perspective, *Journal of Management in Engineering*, 13(5), 37-44.

# Concurrent Delays in Sri Lankan Construction Industry: Challenges and Approaches

W. A. C. R. Premakeerthi\*, R. Thalpage, V. Srivishagan

Division of Civil Engineering, University College Matara, Sri Lanka

## ABSTRACT

*Various delays can be identified in the construction industry at present, and all these types of delays can be divided into the effect on the critical path, the entitlement, and the time they occur. Among these varied delays, concurrent delays can be identified as controversial delays. The effect on the critical path and the delay occur time can be identified as factors influencing the occurrence of concurrent delays. Successful assessment of concurrent delays has become a critical condition in the construction industry. Currently, the SCL delay disruption protocol provides several guidelines, though the construction industry in Sri Lanka is not mature enough to meet them. Handling of concurrent delays in the Sri Lankan construction industry was identified through expert interviews, and this qualitative approach was achieved with six consultants and five contractors. Challenges for the handling of concurrent delays and approaches to solve them in current practices were identified through expert interviews. It was finally recognized that Sri Lanka was unsatisfactory in its handling of concurrent delays. The situation is the same globally. The required knowledge and skills to deal with concurrent delays are not found in construction professionals. By preparing a proper specification, educating parties to involve in the construction and Preparation, and maintenance of programs in a timely manner, activating new records in a systematic manner, and avoiding global claims this can be avoided.*

**Keywords:** Approaches, Challenges, Concurrent delay, Construction.

## 1. INTRODUCTION

The construction project is a process that requires a definite cost, expense, and time to be successful. However, many internal and external factors have positive as well as negative impacts on the project. This results in delays, interruptions, and other claims on projects (Arditi & Pattanakitchamroon, 2006). A construction project is a huge investment and needs to get the right approach from the beginning. The most common factors for delaying a construction project are factors such as financial security, construction drawings, permits, design changes, public utilities, construction conditions, material supply, laws, weather conditions, and environmental factors Marine (2013). Further the same author highlighted that if these factors are taken into consideration from the outset, delays in the construction industry can be avoided. It also helps to stop wasting time and money. The construction industry is always in a state of flux and may not know what will happen next. Because of this, contractors and owners need to focus from the beginning to eliminate the risk of delays and disruptions in the construction industry (Conquering Concurrency, 2018).

According to Marine (2013), it is more common for a project to be delayed by more than one action at a time, which is problematic. This further confirms that contemporaneity is problematic in analyzing the impact of construction delays on project delays and compensation for the extension (Arditi & Pattanakitchamroon, 2006). The ultimate goal of any of these types of analysis is to calculate the extent of entitlement between the employer and the contractor (Pickavance, 2005). If the claim for delays is distributed in an excusable or non-excusable, manner, the claim can be termed as monetary compensation if the claim is considered as a compensable or non-compensable, case as an extension of the contractor's project period (Ward, 2008). It is stated that the issuance of EOT will only take place as long as it is expected that the change in the activities of a project due to a risky event of the employer

---

\* Corresponding Author: E-mail- [rasanthithalpage@gmail.com](mailto:rasanthithalpage@gmail.com)

will be less than zero unless otherwise stated in contract (Anon., 2002). Further, change in the activities of the project describes as, the period during which one or more activities can be transferred without effect from the completion of the contract. Understanding the concurrent delays and their implications in this introduction will enable construction industry professionals to better manage claim management (Ward, 2008).

## 2. CONCURRENT DELAYS

The concurrent delay means that a construction project is delayed by two events at once, the first being the employer taking responsibility under the project contract and the other one the contractor taking responsibility (Conquering Concurrency, 2018). Concurrent delay is shown in the following diagrams simply as true concurrent delay and Keating’s ‘overlapping’ concurrent delay. In a true concurrence delay, the activities of the employer and the contractor occur at the same time, and the delay occurs at the same time and ends at the same time. Keating’s ‘overlapping’ concurrent delay is when the employer and contractor delays start at different times and overlap at one point. This extraction period can be expressed as a concurrent delay period.

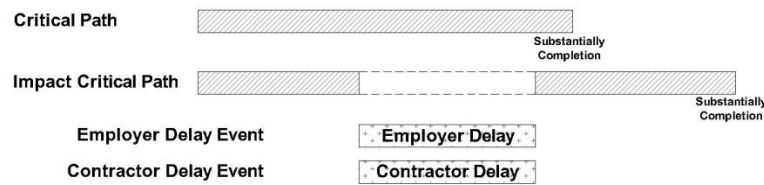

Figure 1: True Concurrency (Robert & Mathew, 2018, p. 3)

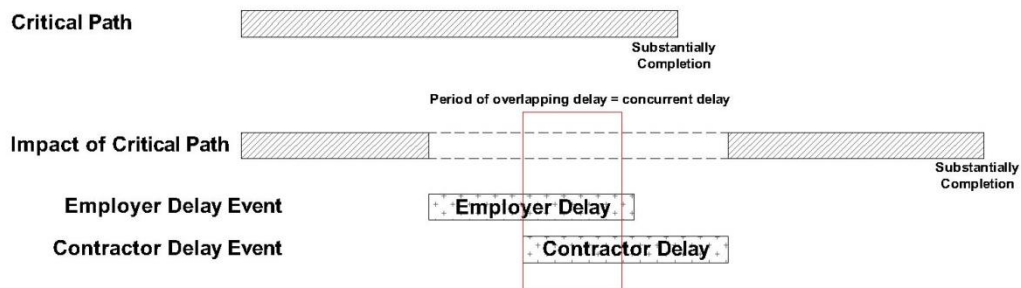

Figure 2: Keating’s ‘Overlapping’ Concurrent Delay (Robert & Mathew, 2018, p. 3)

The concurrent delay is referred to as a difficult problem, as it is a mix of more than one event that occurs at the same time, but where not all of those events can be received the claim of extension of time and money of damages by the Contractor. As per most of the researchers, the delay of project completion can happen in two different ways as time overrun and extension of time (EOT). In the construction industry, concurrent delays can’t be avoided as it creates more critical and grave issues. Therefore, the industry is always trying to solve these concurrent delays. On the other hand, those delays can’t be calculated with numerical or measurable values as these delays were transmitted the difficult areas while creating various issues. The term ‘Money is time’ is the most popular concept in the construction industry which can be used to motivate the number of people who participate in construction projects (Doyle, 2005).

Concurrent delays create the delay completion of projects while delay completion creates serious issues as lower benefits and profit losses to the client. Further, it affects a financial crisis of the client as the increment of loan interest rates, loss of market business, and downward of economical level (Braith, 2008). Moreover, various researches have explored that delay is the most critical issue in the

construction industry as they are connected with the time and cost of projects. At the same time, concurrent delays affect not only the time for completion but also generate a loss of project efficiency, budget exceeds, acceleration, bad company reputation, breach of contracts, and termination of contracts.

### 3. METHODOLOGY

Researchers have been used two different methodologies such as quantitative and qualitatively accepted strategies to obtain data during their research. Thus, this research has been carried out using qualitative data. This is a highly functional process that helps to identify the scope of research. It gave a comprehensive idea of the types of concurrent delays and how they occur.

This study will identify barriers to analyzing concurrent delays in Sri Lanka, and then find solutions to them. Contemporary practice on contemporary delays management is being studied, combining the knowledge of delays in the handling of specialties related to the construction industry in Sri Lanka. Current practice on concurrent delays management will be studied, combining the knowledge of delays in the handling of specialties related to the construction industry in Sri Lanka. Interviews were conducted with experts, consultants, and contractors to obtain the required data as both companies are contributing to the project delays.

Most of the experts who participated in the expert interviews conducted for the qualitative approach in this study have knowledge of concurrent delays and their experience in the field can be shown in table 1 below. As per that, seven of the experts had more than fifteen years of experience in the construction industry and had a good knowledge of how to handle delays.

Table 1: Details of sample for expert interviews

Interviewee	Organization	Position	Experience in Industry (In years)
P01	Consultant	Chartered Quantity Surveyor	8
P02	Consultant	Senior Quantity Surveyor	25
P03	Consultant	Contract Administrator	18
P04	Consultant	Accountant	30
P05	Consultant	Assistant Quantity Surveyor	4
P06	Consultant	Quantity Surveyor	15
P07	Contractor	Director General Manager	22
P08	Contractor	Project Manager	24
P09	Contractor	Supervisor	35+
P10	Contractor	Quantity Surveyor	10
P11	Contractor	Site Manager	12

### 4. RESULTS AND DISCUSSION

This study focuses on identifying challenges in the prevailing practice of handling concurrent delays in the Sri Lankan Construction industry while proposing approaches as solutions for those barriers. The main limitation identified in the findings of this study is that the theory of concurrent delays is fundamentally established. Thus, an understanding of the identification of concomitant delays, their impact on the construction industry, and training on the use of concomitant delays analysis methods were first gained. Most of the interviewees who participated in the interview has been practiced at least a one-time concurrent delay. In concurrent delay practicing, very basic techniques have been implemented but advanced methods such as time impact analysis have not been used. This was due to the scarcity of knowledgeable and talented people. In the practices of the Sri Lankan construction

industry, Delays are not analyzed, and negotiations between the parties end with the issuance of an EOT.

Further study found that it was difficult to identify concurrent delays in the construction industry in Sri Lanka. Lack of knowledge about the subject can also be cited as the reason for this. Accordingly, subject knowledge is essential for the analysis of concurrent delays in the Sri Lankan construction industry. Must have a better understanding of identifying concurrent delays by assessment, baseline program that is properly prepared and properly maintained, and project record keeping. The importance of programming and scheduling is outlined in the introduction of the research. Data collection found that the use of the practice of concurrent delay analysis in the construction industry is at a very low level. However, this can be identified as a minimal information zone in the construction industry in Sri Lanka. Following the conditions of contracts use in Sri Lanka, submission of a project plan with timelines in the relevant period is a poor experience of contractors.

According to the literature review and information provided by experts, techniques that analyze concurrent delays could have been identified as, but for the test, first past the post, dominant cause approach, and common sense technique. One of the most experienced experts in the field noted that *"common sense technology is one of the most important methods of dealing with concurrent delays because it is accepted in court as well."* These interviewers had different types of experience in dealing with concurrent delays, four of which were occasionally practiced. One respondent further stated that *"there is no standard methodology for concurrent delay analysis and it will be difficult to find a project in Sri Lanka that uses the 'dominant cause approach' method."* In the face of the arguments and presentations of the interviewers, it can be understood that there is very little training and knowledge regarding the use of concurrent delays in the construction industry in Sri Lanka.

Almost every interviewer said that programming and scheduling were important for delay analysis and that problems would arise if these were not maintained from the beginning of the project. Further, knowledge and training of experts and consultants in the field of construction, electrical, industrial, etc. should be obtained to formulate the baseline program. In response to this, most consultants noted that the standard of the basic program prepared by the contracting party was very poor. The different challenges to handling these types of concurrent delays, the causes of them, and the measures that can be taken to avoid them are obtained through expert interviews, which are set out in table 02.

Table 2: Challenges, Reasons, and proposed Approaches

Challenges	Reasons	Proposed Approaches
<ul style="list-style-type: none"> <li>• <b>Failure to analyse the causes and effect</b></li> <li>• <b>Failure to update records properly</b></li> <li>• <b>Not proper submitted baseline programme and not update it</b></li> <li>• <b>Not followed baseline programme by contractors</b></li> <li>• <b>Failure to report daily delays</b></li> <li>• <b>Improper daily and overall project planning</b></li> <li>• <b>Poor details on the delay</b></li> </ul>	<ul style="list-style-type: none"> <li>• People are not aware on cause and effect analyse</li> <li>• Lack of knowledgeable people</li> <li>• Lack of awareness of contractors on consequences / losses due to improper implementation of baseline programs</li> <li>• Inaction of people</li> <li>• Lack of qualified people to prepare the required files</li> <li>• Lack of understanding of concurrency.</li> </ul>	<ul style="list-style-type: none"> <li>• Provide knowledge to people</li> <li>• Making people aware on its importance</li> <li>• Education of people</li> <li>• Accountability should be introduced</li> <li>• Recruiting qualified people</li> <li>• Implement proper data collecting method from site level</li> </ul>

<ul style="list-style-type: none"> <li>• <b>Poor documentation</b></li> <li>• <b>Low awareness on concurrent delay analysing</b></li> <li>• <b>Lack of competence deal with concurrent delay</b></li> <li>• <b>Getting advantage by different parties on concurrent delays</b></li> <li>• <b>Difficulty in undoubted</b></li> <li>• <b>No appropriate data delivery method from site</b></li> <li>• <b>The nature of critical path is not identified by people</b></li> <li>• <b>Improper practice of claims procedure</b></li> <li>• <b>Cost of record keeping</b></li> </ul>	<ul style="list-style-type: none"> <li>• Lack of proper understanding among people on what should be mentioned and what should not be done</li> <li>• Lack of knowledge</li> <li>• Adaptation of people for negotiating at the end of the project</li> <li>• Lack of care on grey areas in contracts by regulatory bodies</li> </ul>	<ul style="list-style-type: none"> <li>• Consequences can be occurred due to lack of records</li> <li>• Preparing specifications on the program, formalization, update, owner of the float and etc.</li> </ul>
--	--	--

## 5. CONCLUSION AND RECOMMENDATION

Today, the construction industry has become a major economic tool in a country. Delays are thought to have occurred from the beginning of this economic tool. Thus, in the future, the construction industry will be associated with delays. Concurrent delays were identified in this study as one of the many types of delays in the construction industry. Concurrent delays may seem like a new application to both the employer and the contractor, but they have to be experienced. But there is no explanation for this among many. In some cases, delays caused by separate actions by the consultant and the contractor, in addition to the employer, are also referred to as concurrent delays, which have been identified as the most difficult to control. Global studies on this situation have been widely discussed and solutions have been proposed.

During the expert interviews, a large number of obstacles were identified regarding concurrent delays, and solutions were provided by the interviewees themselves. Some of these are outlined at the end. The solutions they put forward must be within regulation. Regulatory bodies are tasked with identifying and remedying deficiencies and misuse of contractual obligations by the parties. Further, in the event of a dispute arising out of the terms of the Agreement, the parties shall deal with it and take action to avoid such circumstances. It is also possible to provide legally enforceable solutions in cases where they cannot be resolved under the terms of the agreement.

All professionals in the construction industry should be made aware of all contractual matters and responsibilities related to their profession. Many are not educated up to the degree level so they should be educated. Because they act in a way that abuses responsibility.

## REFERENCES

- Arditi D, & Pattanakitchamroon T (2006) Selecting a delay analysis method in resolving construction claims. *International Journal of Project Management*, 24(2), 145-155. doi:<https://doi.org/10.1016/j.ijproman.2005.08.005>
- Braimah N (2008) An investigation into the use of construction delay and disruption analysis methodologies. *Doctoral dissertation*.
- Braimah N (2008). An investigation into the use of construction delay and disruption analysis methodologies. *Doctoral dissertation*. Retrieved from <http://hdl.handle.net/2436/38824> (2018)
- Conquering Concurrency. FTI consulting.



- Doyle J (2005) *Concurrent Delays in Contracts*. Retrieved from [http://www.doylesconstructionlawyers.com.au/public/files/File/Concurrent% 20Delays.pdf](http://www.doylesconstructionlawyers.com.au/public/files/File/Concurrent%20Delays.pdf)
- Eggleston, B. (2009) *Liquidated damages and extensions of time*.
- Faridi A. S, & El-Sayegh S. M (2006) Significant factors causing delay in the UAE construction industry. *Construction Management and Economics*, 1167- 1176.
- Hamzah N, Khoiry M, Arshad I, Tawil N and Che Ani A (2011) Cause of Construction Delay - Theoretical Framework. *The 2nd International Building Control Conference 2011* (pp. 490-495). Elsevier Ltd. doi:<https://www.sciencedirect.com/science/article/pii/S1877705811030013?via%3Dihub>
- Iyer K, Chaphalkar N, Joshi G (2008) Understanding time delay disputes in construction contracts. *International Journal of Project Management*, 26(2), 174-184. doi:<https://www.sciencedirect.com/science/article/abs/pii/S0263786307000828?via%3Dihub>
- Keane P and Caletka A (2008) *Delay analysis in construction contract*. doi:10.1002/9781118631102
- Kraiem Z and Diekmann J (1987) Concurrent delays in construction projects. *Construction Engineering Management*, 591-602. Retrieved from <https://ascelibrary.org/doi/pdf/10.1061/%28ASCE%290733-9364%281987%29113%3A4%28591%29>
- Kraiem Zaki M, Diekmann James E (1987) *Concurrent Delays in Construction Projects*, 591-602.
- Marine J (2013) Concurrent delay revisited. *Society of construction law*. London. Retrieved from <https://tecbar.org/wp-content/uploads/2016/05/2014-Concurrent-Delay-Revisited-John-Marrin-QC.pdf>
- Menesi W (2007) Construction Delay Analysis under Multiple Baseline Updates. Retrieved from <http://hdl.handle.net/10012/2737>
- Peter T. F (2003) Dissecting the doctrine of concurrent delay.
- Pickavance K (2005) *Delay and Disruption in Construction Contracts*. Great Britain: MPG Book Publishers.
- Robert, G. & Mathew, C., 2018. *Conquering Concurrency*, s.l.: FTI Consulting.
- Samad M.E.S, Razkenari M. A, Barati K (2007) The Importance of New Technology for Delay Mitigation in Construction Projects. *International Journal of Project Management*, pp. 517-526. doi:<http://www.sciepub.com/reference/98405>
- Ward P (2008) Proceeding of International Conference on Building Education and Research. *An American perspective of the suitability of the SOCL's Protocols provisions for dealing with concurrency on Australian construction projects*, 1299-1310.
- Williams T (2003) Assessing Extension of Time delays on major projects. *International Journal of Project Management*, 19-26. doi: [https://doi.org/10.1016/S0263-7863\(01\)00060-6](https://doi.org/10.1016/S0263-7863(01)00060-6)

# Site-Level Patronage Given to Covid-19 Health Protocols; A Sri Lankan Experience

Thilini Andawala\*, Chandana Jayalath

Department of Quantity Surveying, University of Vocational Technology, Sri Lanka

## ABSTRACT

*Since March 2020, the physical execution of construction projects has been temporarily suspended due to the COVID-19 pandemic. This is affecting not only the labor employment, industries but also many of their family members. This segment of society accounts for nearly 20 Million population in Sri Lanka. Recently, a health protocol was introduced by the Construction Industry Development Authority (CIDA) in Sri Lanka with the purpose of enhancing resiliency among construction workers. Hence, it is time a post review is undertaken to see whether the protocol guidelines have been successfully adopted at the site level and if so, to what extent. A desk review was carried out to offer an overview of the CIDA health protocol. A questionnaire survey was carried out using Google Forms to gauge the perception of site-level personnel on their hands-on experience as to how the guidelines are being currently implemented. Out of 385 invitees of weekend students already employed at various sites island-wide, 130 invitees had responded with the full details sought. It was found in the manual content analysis that the patronage given by the site management in adherence to the standard protocol is not satisfactory at all. Measures must be taken to improve the level of implementation via constant monitoring, warning, and legal actions as already mentioned in the protocol.*

**Keywords:** CIDA health protocol, Construction labor, COVID-19, Site management.

## 1. INTRODUCTION

Almost every construction project other than a few vital projects has been shut down (Gamil & Abdulsalam 2020). To mitigate the spreading of the COVID-19, travel restrictions, social distancing, and quarantine curfew was imposed. Due to that construction industry has to face unprecedented delays, disruptions, and uncertainty on construction projects. (Robert et al 2020). Also, Robert et al (2020) mentioned that those reasons resulted to distract the supply chains, contractor workforce, and the availability of governmental personnel for project inspections. Morris (2020) explained the main critical challenges that have been incurred due to the pandemic. Such as (1) delay and suspension of ongoing projects; (2) cancellation of new projects; (3) supply chain problems, production delays, and logistic jams; (4) formation of additional and new risks related to the workplace, job sites, and contract responsibilities; (5) workforce issues containing with a shortage of labor, protection of workers, ensuring proper health and safety precautions, and decreased manpower; and (6) financial problems. Adhikari & Poudyal (2021) derived that the existing risk plans need to be inspected for their capability of handling new risks. Many organizations published some health and safety protocols to mitigate the impacts related to their industries. While social distancing interventions were in place, most new cases, hospitalizations, and deaths were averted, even with modest reductions in contact among adults (Laura M., and Tiffany L, (2020). However, Moosa (2020) mentioned that social distancing is effective, even though it is hard to separate the effect of government measures from that of social distancing triggered by personal initiatives. The ILO (2021) published a document that explained the COVID-19 impact on the construction industry, supply chain, workforce, and protection measures. Some of the measures are indeed novel to the construction industry. The literature review that I examined suggested that existing research findings on social distancing are unpredictable and that the quality of the accumulated evidence is not excessively strong. Also, there is rather limited evidence of the effectiveness of social distancing measures and also many measures are described in the research literature as being “moderately

---

\* Corresponding Author: E-mail: [thilini92and@gmail.com](mailto:thilini92and@gmail.com)

effective.” Abouk and Heydari (2020), Begley (2020), Calsyn and et Al (2020), Frank (2020), Hensley (2020), Johnson and et al (2020), Kumar (2020), Tangermann (2020) findings also tend to be inconsistent regarding the acceptance as well as social and economic costs of social distancing measures. The ILO (2021) published a document that explained the COVID-19 impact on the construction industry, supply chain, workforce, and protection measures. Some of the measures are indeed novel to the construction industry.

The lack of knowledge underscores the significance of investigating social distancing policies and their measures have been really effective. It is also relevant to investigate how various authorities offer directives and the extent to which these directives are proclaimed to be based on research. There is also a need to investigate how measures are perceived, accepted (or not), and acted upon, and complied with by the construction workers. Due to the novelty of COVID-19 as a pandemic, measurable data are still scarce. This research is to address the above knowledge gap in the Sri Lankan context based on the Health and Immunity Enhancement Guideline for COVID 19 and DENGU published by Construction Industry Development Authority (CIDA). CIDA was published this protocol to ensuring that all features of health should have been implementing before stepping in to the construction site. Through the research discuss about the effectiveness of this protocol by conducting a survey among the site level personnel.

## **2. RESEARCH AIM AND OBJECTIVES**

The aim of this research is to assess the adoption and effectiveness of CIDA’s COVID19 safety protocols at the level. The findings will help to gage for serious adoption of the health protocol requirements for a resilient workforce and increase alertness among the construction industry personnel on the same. The research has several objectives as follows.

- To identify key requirements of the Sri Lankan protocol.
- To explore the level of implementation at sites and identify challenges that have to be faced during implementation.

## **3. RESEARCH METHODOLOGY**

A desk review was carried out to identify the key requirements of the health protocol in Sri Lanka which has been officially published by the CIDA in August 2020. A questionnaire survey was adopted using Google Forms to gather feedback on the level of implementation of the protocol at the site level. For decide the sample size selected “Cochran Formula” which is considered to be appropriate in situations in larger populations was adopted to decide the sample size (Glenn D. Israel, 2013). Meanwhile, there are many advantages associated with the use of information technology to support approaches to evaluation. As an example, Watt et al. (2002) mentioned that ‘using web-based evaluation questionnaires can merge many of the bottlenecks in the evaluation system (e.g. data entry and administration) and move to a more “just in time” evaluation model’. Another benefit is avoiding the need to manage surveys in class (Dommeyer et al. 2004). As such, Google Forms were used to collate qualitative data regarding hands-on experience of the site level personnel to a 5 point Likert scale. Content analysis (though originally introduced as a strictly quantitative method), was done recording counts to measure the observed frequency. Its validity still remains, for instance, to facilitate data analysis (Lewis, Zamith, & Hermida, 2013).

The number of invitees were decided by the use of Cochran formula. For populations that are large, Cochran (1963:75) developed a formula to yield a representative sample for proportion, as follows.

$$n_0 = \frac{Z^2pq}{e^2} \tag{Eq. 1}$$

where ‘e’ is the desired level of precision, ‘p’ is the estimated proportion of an attribute that is present in the population, and q is 1-p.

The value for Z is found in statistical tables which contain the area under the normal curve. Since the variability in the proportion that will adopt the health protocol in practice is not exactly known, it was assumed a p p-value of 0.5 (maximum variability). Furthermore, a 95% confidence level and ±5% precision are considered. The resulting sample size is 385 students working at the site level during weekdays. This pool of students was picked up from a University of Vocational Technology in Sri Lanka. This weekend part part-time students are full full-time employees at different organizations namely constructing, consultation, and employer entities, both private and public, working as site supervisors, quantity surveyors, engineering assistants, and technical officers. One of the basis of selection is that the respondents should have been placed at the site level so that they get the first first-hand information as to site site-level implementation of the protocol. Also, the validity of the conclusions depends largely on whether the sample used is representative enough. Fig 1 shows that the profile of the respondents.

**4. RESEARCH FINDINGS AND DISCUSSION**

In Sri Lanka, the purpose of the Health and Immunity Enhancement Guidelines for COVID-19 & DENGUE in the construction industry published by the CIDA is to ensure that all aspects of health be strictly implemented before stepping into the sites. The directives are meant to be followed by construction sites operating in Sri Lanka as a controlling mechanism. The guidelines aim to prevent the spreading of COVID-19 and DENGUE and to promote good health among construction workers and staff. However, it is the responsibility of the managers and others in the workforce to take sufficient steps to refer to reliable sources for updates related to the developments associated with COVID-19 to ensure the control of this pandemic. This technical guideline describes the sources of COVID -19 & DENGUE, its symptoms, and discusses health precautions that need to be taken for health issues that occur due to COVID-19 and DENGUE. And also guidelines discuss the obligations of each stakeholder of the construction industry such as contractors, employers, and any other workers. The roles and responsibilities of the employers in the construction industry as well as the CIDA to mitigate both COVID-19 and DENGUE are explained further. The directives relevant to COVID-19 are given in a summary form in Table 1 below.

Table 1: Key Directives of CIDA Health Protocol, 2020

Ref	Content	Directives
4.1	Role of CIDA in preventing COVID-19	Observation team for monitoring health practices at construction sites
4.2	Employer’s duties	Plan and implement preventive measures Provide personal protective equipment and clothing
4.2.1	Allocation of funds Contractual Obligations of the Contractor	Provide financial allocations for safety precautions Assign an Officer (Safety & Occupational Health supervisor) Regular inspection Regular Capacity Building and training workshops Weekly updates Consolidated monthly summary report Workers not be left behind in the protection of their health

<b>4.3</b>	Workers should support in preventing COVID-19	Volunteer contribution in preventive actions Participate in training Report in case of suspicion Leave themselves from any work situation that they have reasonable justification to believe of having COVID-19
<b>4.4</b>	Preventive Hygiene Best Practices	Continuous health checks Washing hands and sanitization Personal hygiene Welfare facilities Exit procedure after work Transport facilities Accommodation arrangements Sanitary facilities, lunch rooms and canteens and changing rooms
<b>5</b>	Site administration	Waste Disposal at construction sites Personal Protective Equipment Appoint Construction Safety & Occupational Health Supervisors Facilitate PHI in site visits Impose fine for violators Operate only with resident workers Appoint Health and Safety Committee Introduce a shift work system Arrange a system for physical distancing Body temperature checking procedures Postpone non-essential activities Develop a COVID-19 Preparedness plan Special load/offloading arrangements Traditional practices
<b>6</b>	Supplementary Provisions	

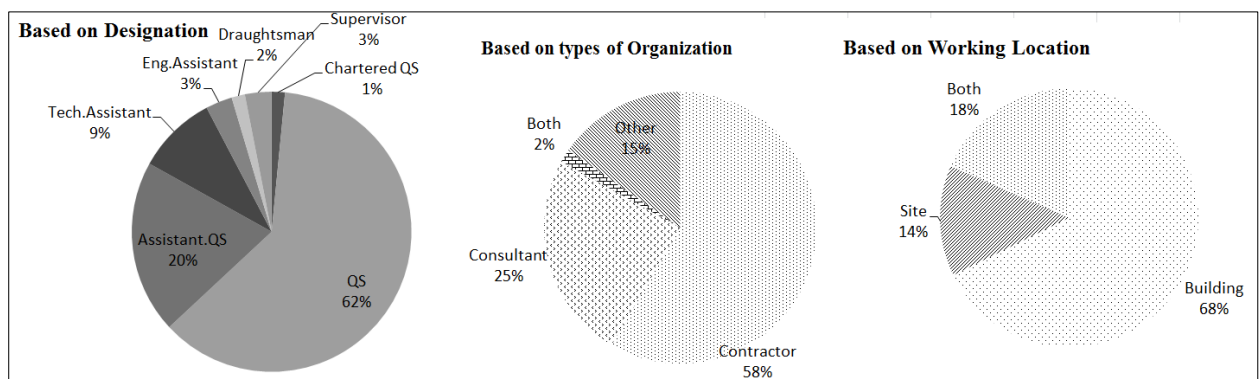

Figure 24: Profile of respondents

Though the data was collated using a five-point Likert scale, the data was further manually categorized into three basic levels of their adherence namely not implemented at all, implemented loosely (with no seriousness) and strictly implemented. Three patterns were assigned to denote this level of adherence; respectively in Figure 2, Figure 3, and Figure 4.

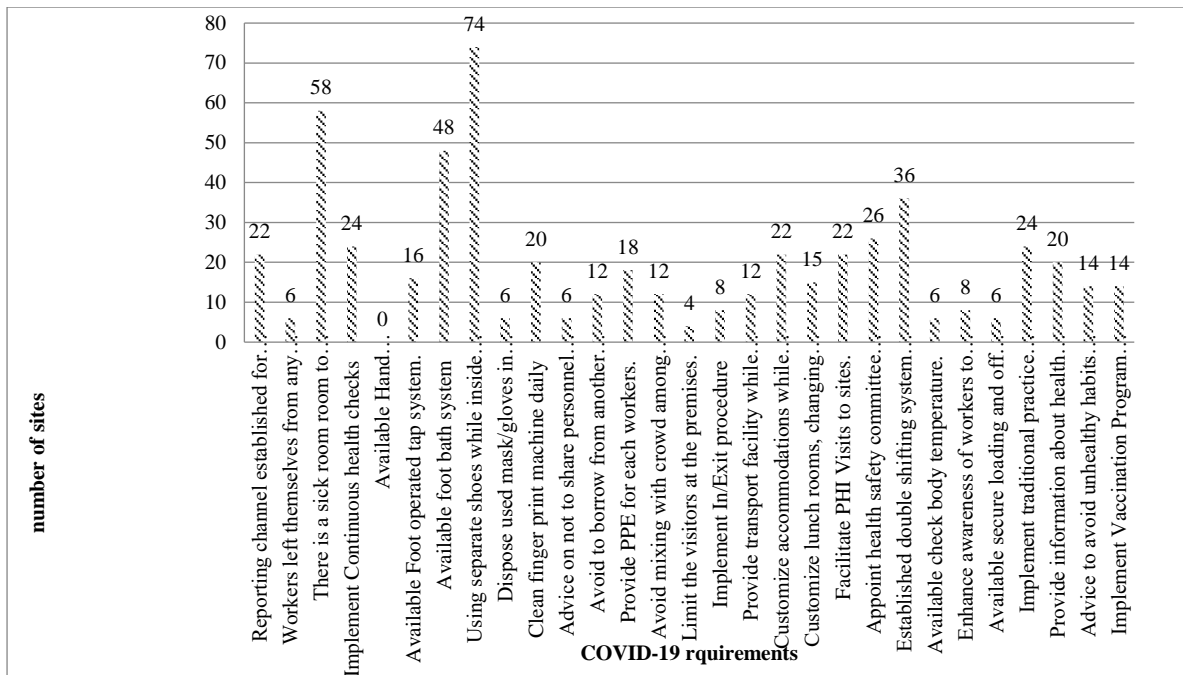

Figure 25: sites where no directives has been followed at all

Coronavirus may remain for a long time on various surfaces which is a major reason for its transmission. (Suman et.al, 2020). Therefore many health protocols advise to using separate safety kits, clothes, shoes for separate locations. Unfortunately, 74 sites report no separate shoes for workers while inside the site. 58 sites have no dedicated sick room for their workers. It may affect to transmission of virus particles from outside to inside same as from inside to outside.

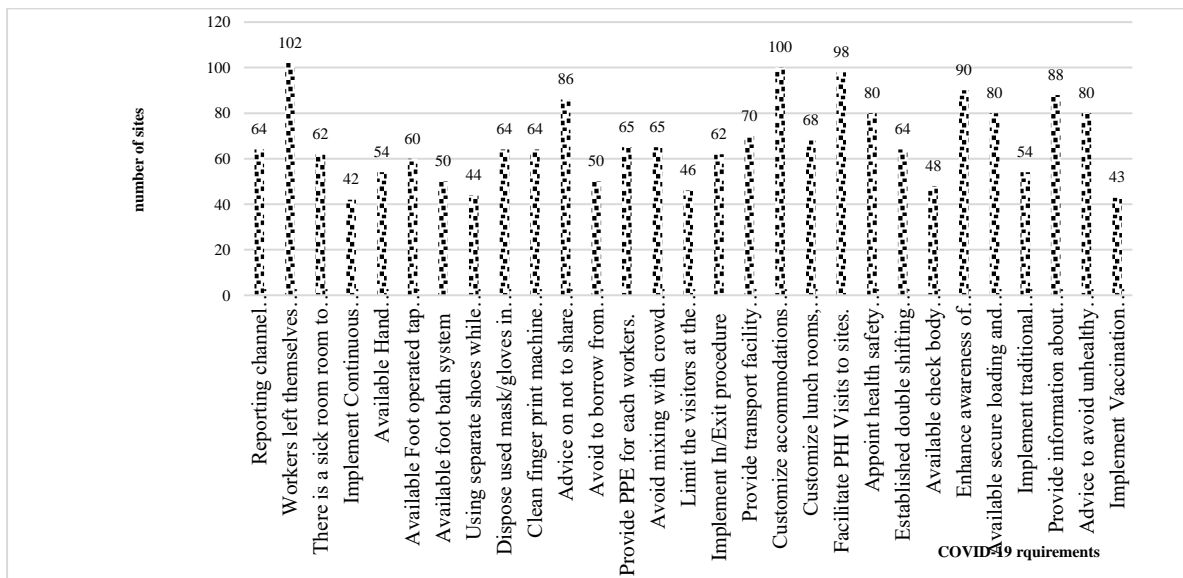

Figure 3: sites where directives have been not seriously followed

It is seen that a considerable number of sites follow no serious advice. In this sense, these sites report that their workers are left themselves from any work situation that they have reasonable justification to believe of having COVID-19 (78%) and customize accommodations while increasing hygiene level (77%). Facilitating PHI visits to sites has been reported as 75% whereas enhancing awareness among workers about the pandemic to avoid any further danger from new cases of COVID-19 is 69%. WHO reported that around one in six people who gets the infection may become severely ill, and others are

not. Hence if someone believes that he/she has any symptoms of COVID-19, he or she should be isolated from the rest of the staff to avoid spreading. Fig 3 illustrates that a substantial number of sites are not that serious.

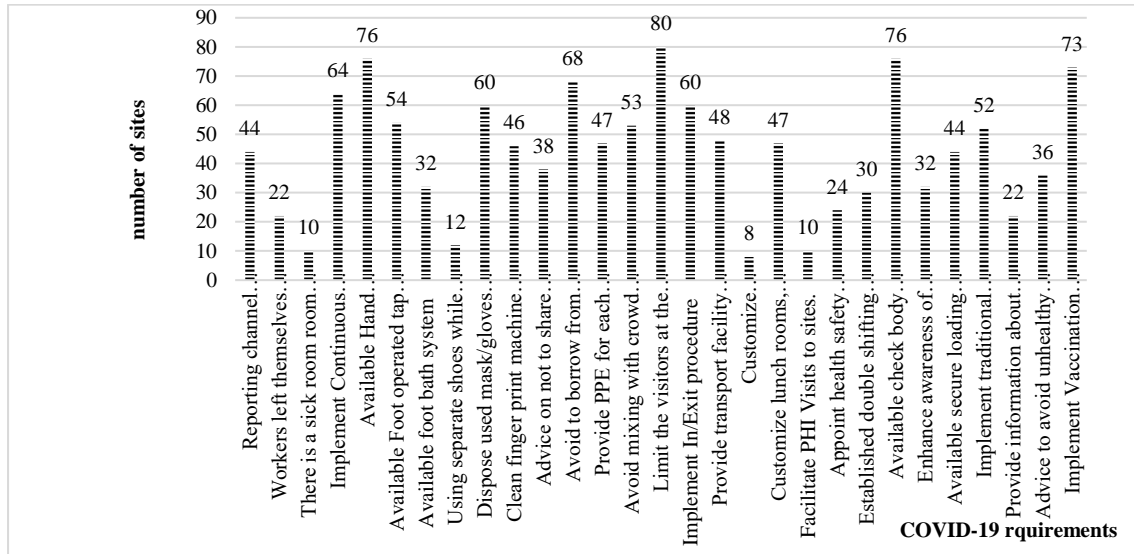

Figure 4: sites where directives have been strictly followed

Figure 4 demonstrates the level of strict compliance. Between 55%- 62% sites are strictly following basic health measures that help minimize the spreading of COVID-19 such as limiting visitors to their premises, check body temperature, hand washing, sanitization facility and implement vaccination programme. However, the number of sites strictly following the health protocol is less than 50%.

**5. CONCLUSION**

Considering the responsibility vested to assure the best health in the constructions workforce, CIDA published this guideline to educate the industry stakeholders to ensure safety from both COVID-19 and DENGUE. The main aim of this protocol is to protect human lives associated with the construction sites, from the dangers due to COVID-19 and DENGUE, thereby leading to the sustenance of the construction industry. It will not that be meaningful as intended provided site management is not taking seriously its implementation at the site level. Fig 1 is pretty obvious. 50% of sites are not seriously following health measures. This situation is not optimistic at all. It will not only increase the probability of temporary suspension of construction sites leading to cost and time overrun but also cause detrimental effects on their workforce.

In construction sites, workers are would become very vulnerable and get exposed to a high risk of getting infected or spreading the disease. Therefore it is very significant to take appropriate remedial measures to minimize the impact. It is time for strict actions forthwith taken to correct the situation at the site level.

**REFERENCES**

Abouk, R, and B. Heydari. 2020. "The Immediate Effect of COVID-19 Policies on Social Distancing Behavior in the United States." SSRN. <https://ssrn.com/abstract=3571421>

Adhikari, K., Poudyal, L 2021, 'Future of Construction Industry: COVID-19 and its implications on construction projects and risk management – A review', doi:10.20944/preprints202104.0383.v1

Begley, S. 2020. "Social Distancing Is Controlling COVID-19; Now Scientists Need to Figure Out Which Measures are Most Effective." <https://www.statnews.com/2020/04/09/social-distancing-controlling-COVID-19-which-measures-are-most-effective/>

- Calsyn, M., E. Gee, T. Waldrop, and N. Rapfogel. 2020. "The Effect of Social Distancing in Containing the Coronavirus: A Comparative Study." Center for American Progress, March 25. <https://www.americanprogress.org/issues/healthcare/news/2020/03/25/482278/social-distancing-fight-coronavirus-strategy-working-must-continue/>
- Dommeyer, C.J, Baum,P,Hanna,R,W,Chapman,K.S 2004, 'Gathering faculty teaching evaluations by in-class and online surveys: their effects on response rates and evaluations. *Assessment & Evaluation in Higher Education* 29, no. 5: 611–623
- Frank, T. A. 2020. "Can You Beat COVID-19 without a Lockdown? Sweden Is Trying." *Vanity Fair*, April 16.
- Gamil, Y, Alhagar, A 2020, 'The Impact of Pandemic Crisis on the Survival of Construction Industry: A Case of COVID-19', *Mediterranean Journal of Social Sciences*, DOI: <https://doi.org/10.36941/mjss-2020-0047>
- Glenn D. I 2013, 'Determining Sample Size', University of Florida, IFAS Extension, PDOD6
- Hensley, L. 2020. "Social Distancing Is Out, Physical Distancing Is in—Here's How to Do It." <https://web.archive.org/web/20200326180136/https://globalnews.ca/news/6717166/what-is-physical-distancing/>
- Imad A. Moosa , (2020,) The effectiveness of social distancing in containing COVID-19, *Applied Economics*, 52:58, 6292-6305
- International Labour Organization 2021, Impact of COVID-19 on the construction sector..
- Johnson, C. Y., L. Sun, and A. Freedman. 2020. "Social Distancing Could Buy U.S. Valuable Time Against Coronavirus." *Washington Post*, March 7.
- Kumar, S. 2020. "Corona Virus Outbreak: Keep Physical Distancing, Not Social Distancing." SSRN. <https://ssrn.com/abstract=3568435> [Crossref],
- Laura Matrajt and Tiffany Leung, (2020,) Evaluating the Effectiveness of Social Distancing Interventions to Delay or Flatten the Epidemic Curve of Coronavirus Disease, *Centres for Disease Control and Prevention*, Volume 26, Number 8—August 2020
- Lewis, S C, Zamith, R, & Hermida, A 2013, 'Content analysis in an era of big data: A hybrid approach to computational and manual methods'. *Journal of Broadcasting & Electronic Media*, 57(1), 34–52.
- Morris, GDL, 2020, '6 critical COVID-19 risks for the construction industry,' Accessed June 7, 2020. <https://riskandinsurance.com/6-critical-COVID-19-risks-for-the-construction-industry/>.
- Richardson, J.T.E 2005, 'Instruments for obtaining student feedback: a review of the literature', *Assessment & Evaluation in Higher Education* 30, no. 4: 387–415
- Robert, R., Kentish-Barnes, N., Boyer, A. et al. Ethical dilemmas due to the Covid-19 pandemic. *Ann. Intensive Care* 10, 84 (2020). <https://doi.org/10.1186/s13613-020-00702-7>
- Suman, R, Javaid, M, Haleem, A, Vaishya, R, Bahl, S, & Nandan, D 2020, 'Sustainability of Coronavirus on different surfaces', *Journal of Clinical and Experimental Hepatology*, 10, 386– 390.
- Tangermann, V. 2020. "It's Officially Time to Stop Using the Phrase 'Social Distancing'." *Science Alert*, March 24. <https://www.sciencealert.com/who-is-no-longer-using-the-phrase-social-distancing>
- Watt, S, Simpson, C, McKillop, Nunn,V 2002, 'Electronic course surveys: does automating feedback and reporting give better results', *Assessment & Evaluation in Higher Education* 27, no. 4: 325–337.



## **OPTIMIZING VALUE OF FOOD TECHNOLOGIES**

# Health Effects and Physicochemical Properties of Traditional Rice Varieties vs Improved Rice Varieties

Yasintha Wickramasinghe, M. M. J. O. Wijekoon\*

Division of Applied and Natural Sciences, University College of Matara, Sri Lanka

## ABSTRACT

*Rice is the second largest food in the world and as the staple food of Sri Lankans rice plays a significant role in health aspect. An increasing trend of non-communicable diseases has been reported among Sri Lankan people whereas conducting researches on health effects of rice is momentous. People are looking healthiest food nowadays hence the demand from consumers has also increased. Some are arguing that there is a potential for non-communicable diseases with the consumption of improved rice varieties since those varieties are low in nutritional value and high in glycemic index. Most of the research findings show high nutritional values, low glycemic effect, and medicinal values in traditional rice cultivars of Sri Lanka. This review presents a critical overview of the health effects of traditional and improved rice varieties in Sri Lankan context.*

**Keywords:** *Glycemic Index, Health effects, Improved Varieties, Nutritional Value, Sri Lankan Traditional Rice.*

## 1. INTRODUCTION

Rice (*Oriza sativa* L.) is the primary food of almost half of the world's population whereas the consumption rate of rice of Sri Lankans is over 100 kg/ person annually (Diyabalanage *et al.*, 2016). Rice contributes to 45% of total calorie and 40% of total protein requirement of a mean Sri Lankan. The main component of rice is a complex carbohydrate and it has adequate amount of protein and fat as well as a good source of vitamin-B complex as thiamine, riboflavin, and niacin (Fresco, 2005). Starch is the main carbohydrate (75%-80%) of rice which is composed of amylose and amylopectin and rice is consisted of 12% of water, 7% of protein with a full complement of amino acids. Rice protein is highly digestible which is around 93% with 74% of excellent biological value and protein efficiency ratio (2.02%–2.04%) with the presence of higher concentration (about 4%) of lysine. Rice grain consists of minerals like calcium (Ca), magnesium (Mg) and phosphorus (P) alongside some traces of iron (Fe), copper (Cu), zinc (Zn) and manganese (Mn) (Juliano, 1993). The nutritional values of rice are varied with different varieties and with agronomic conditions such as soil fertility, fertilizer application, and other environmental conditions. Rice can be classified as aromatic and non-aromatic rice based on aroma; aromatic rice emits a special aroma when cooking which is sold at a high price in local as well as international market (Verma *et al.*, 2015)

Rice Varieties which are passed down from previous generations are notorious as 'traditional', 'indigenous' or 'inheritance' rice cultivars in Sri Lanka and they have been conserved as well as developed by farmers over 3000 years. During Granary of the East, more than 1000 traditional rice varieties were cultivated and those varieties consist of strong characteristics which are unique to traditional varieties that help them to survive under extreme environmental conditions as droughts, heavy rains, and floods but newer varieties are grown in chemical intensive paddy cultivation. Those indigenous varieties were grown coupled with traditional agriculture in which organic fertilizer and other environmental friendly agronomic practices were used. Further, traditional cultivars grown under traditional agriculture practices have been verified to be more successful growth under climate change events such as droughts and floods, through continuous rigorous research (Rambukwella, 2016).

However, to cater to the demand for paddy with the increase of population, the "H" series rice varieties were introduced in 1950 along with the use of chemical fertilizer. In early 1960, with the "Green Revolution", chemical fertilizer was subsidized and irrigation systems were established. As a result,

---

\* Corresponding Author - Email: [jeevani@ucm.ac.lk](mailto:jeevani@ucm.ac.lk)

farmers were motivated to grow improved paddy varieties with the aim of heavy production. Even though introduced new improved varieties were high yielding within short time duration, they were chemical fertilizer dependent and labour intensive with low vigorous under extreme weather conditions. After 1950, over six dozen new varieties were released to the rice market and about 15 hybrid varieties are dominating today's rice harvest (Rambukwella, 2016).

## 2. PHYSICOCHEMICAL PROPERTIES OF RICE

Due to the increasing trend of various sorts of diseases especially non-communicable diseases, people try to seek out healthy food rich in nutrients and with medicinal value. Researches are conducted to research the agronomic, physicochemical, nutritional, and health effects of traditional rice sorts of Sri Lanka. Most of the researches are conducted to research the physicochemical, nutritional, antidiabetic, and antioxidant properties of some selected traditional varieties (Nadini, Godakumbura and Prashantha, 2019).

Recent research conducted by Abeysekera W. K. S *et al.*, (2017), has found that there is a significant variance within the physicochemical as well as nutritive properties among rice varieties. Among the tested varieties, *Pachchaperumal*, *Wanni Dahanala*, *Rathu Heeneti*, *Kalubala Wee*, *Dahanala* (red rice), *Suduru Samba*, *Kattamanjal*, and *Rathal* (white rice) varieties identified as superior in nutritional characters such as Protein, Fat, Iron, and Zinc contents. Further, the varieties *Pachchaperumal*, *Suduru samba*, *Wanni Dahanala*, *Gonabaru*, and *Sudu Heeneti* had the absolute best crude protein, crude fat, crude ash, total carbohydrate, and dietary fiber contents, respectively. Another study was conducted to investigate nutritional and antioxidant properties of five number of indigenous red and polished rice sorts of Sri Lanka namely *Kurulu Thuda*, *Nilkanda*, *Heeneti*, *MaaWee*, and *Suwadal*. Results show the significant ( $P < 0.05$ ) differences of both nutritional and antioxidant properties among the varieties tested. Supported the results, *Suwadal* was the absolute best in total dietary fiber, *Heeneti* had the absolute best crude ash content while *Maa Wee* had the absolute best protein and sugar contents. Both *Suwadal* and *Kurulu Thuda* showed the absolute best fat content. Further, monounsaturated fatty acid was the foremost predominant acid altogether rice bran oil types. The very best oleic and palmitic acids were observed in *Kurulu Thuda* while *MaaWee* had the higher linoleic acid content. For antioxidant properties, the absolute best activities were observed for the red rice variety *Kurulu Thuda* while white rice variety *Suwadal* had the lowest. However, between red and polished rice varieties variation was significant ( $P < 0.05$ ) just for the antioxidant Properties (Samaranayake *et al.*, 2017).

Investigations have been done for unpopular rice varieties known as *Gurupiya rice* variety which have been derived from traditional rice variety. It has been found that this new red pericarp variety can be consumed as a nutritionally complete healthy food that is rich in good, unsaturated fatty acids and minerals compared to improved rice varieties in Sri Lanka also as in other Asian countries. It is found that this novel variety is rich in protein ( $12.0 \pm 0.1\%$ ), high fiber content ( $1.5 \pm 0.1\%$ ), and high amount of Zn content. Palmitic acid (16:0) and oleic (18:1n-9) are identified as the most prominent fatty acids and Oleic acid is the highest abundant fatty acid (63.55%) which is considered as an essential fatty acid required for human growth and development (Thushara, Godakumbura, and Prashantha, 2020). When considering the proximate composition of aromatic and non-aromatic rice, it is observed that mineral content and fatty acids profiling are different among these types (Verma and Prem, 2017). Further, rice flour plays a major role in preparing functional foods. Results revealed high amount of total phynolic content (68-86%) and antioxidant activity (86-90%) in the brown rice flour samples of traditional varieties than improved types when analysing physicochemical properties of rice flour among these two to explore their value as functional foods (Gunaratne *et al.*, 2011). Based on the results of most investigations it is clear that traditional varieties shows great characters in physicochemical, nutritional, antioxidant and other properties.

## 3. HEALTH EFFECTS OF RICE

Kariyawasam *et al.*, (2016), has cited in their findings that although there are over 2000 Sri Lankan traditional rice types in Sri Lanka, number of only 30 varieties have been analyzed and proven to possess high nutritional and medicinal properties. Some research has been conducted to explore the effect of

consuming different rice variety on blood glucose level and anti-diabetic effects. According to the in vivo and in vitro analysis of bran extracts of rice such as *Sudu Heeneti*, *Goda Heeneti*, *Masuran*, and *Dik Wee* varieties it is found that all the selected traditional varieties show methylglyoxal (MGO) mediated protein glycation inhibition and acetyl and butyryl- cholinesterase inhibitory activities. *Masuran* variety exhibit anti-hyperglycemic action in rat model while other three varieties showed low starch digestion rate ( $52.40 \pm 1.44$  to  $53.76 \pm 1.19$ ) demonstrating low glycemic index (GI) characteristics of the varieties which had good physicochemical properties for consumer preference. It indicates the possibility of selected varieties to be promoted as a solution for management of diabetes and its complications (Abeysekera *et al.*, 2015). Parboiled rice is more popular in some areas of Sri Lanka and it is assumed that the nutritional content of parboiled rice is higher than that of un-parboiled rice. Generally, rice amylose content and the Glycemic Index (GI) have strong negative correlation whereas parboiling of rice lowers the GI of most of the rice varieties. It has been shown that most of the studied traditional rice types exhibit low GI value than improved types and based on the research findings it clear that the grain pericarp colour is not exactly a noble indicator when predicting its glycemic index as generally considered. Further, according to the findings of the present studies it has been found that the GI of rice is varies significantly with the varietal differences of rice types ranging moderate to high (Pathiraje *et al.*, 2011) revealing the importance of conducting tests to detect glycemic indexes of different rice types and categorizing those types according to the GI value; most importantly popularize rice varieties with low GI. Another outstanding research, which has been conducted to screen anti-amylase and anti-glycation activities of brans of selected 23 traditional and 12 improved (both red and white) rice varieties has been identified that rice bran extract of red rice types of improved category show high anti-amylase and anti-glycation activities than that of tested both white and traditional types as *Masuran*, *Sudu Heeneti*, *Dik Wee* and *Goda Heenety* Which show dose dependant anti-glycation, glycation reversing actions and anti-glycation activities as well as marked antioxidant properties (Premakumara *et al.*, 2013). Among the tested traditional rice cultivars for GI, known as *Madathawalu*, *Kaluheenati*, *Wedaheenati* and *Rathkaral* which are red- pigmented rice have been identified as rice types with low GI value whereas there is no significance difference in the amylose content of the same (Rohitha, 2018). Some results also revealed that amylose content alone isn't an honest predictor of starch digestion rate or glycaemic response and rice varieties with high amylose content may have different physicochemical characters such as gelatinization which can be influenced starch digestibility and increase blood glucose level (Panlasigui *et al.*, 2018).

Sri Lanka is among of the richest countries with pigmented rice varieties. One of the most imperative research has been conducted by Gunaratne *et al.*, (2013), to investigate the presence of Proanthocyanidin of both improved and traditional cultivars in Sri Lanka. Eight number of traditional red-grained rice types known as *Kalu Heenati*, *Sudu Heenati*, *Beheth Heenati*, *Rathu Heenati*, *Madathawal*, *Kahatawee*, *Sulai*, and *Molligoda*; which have been identified as proanthocyanidin containing types and they have higher antioxidant capacity with major different antioxidant components and higher nutritional components than that of tested improved types as Bg250, Bg300, and Bg359. Major phenolic compounds which have been identified in traditional cultivars are proanthocyanidins and phenolic acids. Out of those components, Proanthocyanidins were detected as the dominant phenolic compounds within the tested traditional rice types. These findings provide much evidence regarding the nutritional quality as well as phytochemical information of underutilized and less grown traditional cultivars in Sri Lanka.

Identification and popularizing rice types; which are rich in proanthocyanidins may be valuable in order to prepare functional foods and other types of value added products among the people. These cultivars could be beneficial to be used as important genetic sources in breeding different varieties in order to develop high quality rice types. Further most of the research have been identified most of the traditional types are superior in protein content with well-balanced amino acids, higher amount of fat, fibre and vitamins such as Vitamin E (tocopherols and tocotrienols) and vitamin B than new improved rice cultivars. Pigments and phytochemicals in grains are important components which are attributed to most of the positive nutritional characteristics as avoidance of cardiovascular diseases and cancers in humans. There is a possible range of phytochemicals in red and black rice cultivars in Thailand, China as well as in Sri Lanka (Sompong *et al.*, 2011).

Some of the recent studies are focusing on the heavy metal content of rice varieties since acute kidney disease is reported in many rice farming areas in the country. Kariyawasam *et al.*, 2016, has conducted a research to investigate proximate composition, calorie content, and heavy metals such as As, Cd and Pb content of selected Sri Lankan traditional rice cultivars. According to the results it is found that selected varieties contain a higher amount of proteins compared to the improved varieties. The amount of tested heavy metals as As, Cd and Pb were below the limits of quantification (LOQ). LOQ: Pb-0.04 ppm, As-0.02 ppm, and Cd-0.01 ppm. Consequently, this proves that the consumption of traditional rice types may not be affected heavy metal toxicity. Nevertheless, all most all the tested traditional rice cultivars showed higher nutritional values and the highest was found in *Kalu Heenati* among studied varieties known as *Kalu heenati*, *Pokkali*, *Gurusinghe wee*, *Kahawanu*, *Sudu murunga* and *Unakola samba*. Most of the heavy metals are contained in chemical fertilizers which are used in improved paddy cultivation. Generally traditional rice varieties are cultivating using organic fertilizers in traditional farming systems due to their ability to grow well under low inputs in the fields. Nevertheless, traditional varieties can be grown well without using pesticides, insecticides and weedicides due to their resistance for diseases and weeds although the improved rice types highly depend on those chemical inputs.

A research has been conducted by Diyabalanage *et al.*, (2016) to find out trace metal contents of rice in different climatic regions. Further, they have investigated the amount of trace metals of indigenous rice and improved rice varieties since it has been reported that rice contains high levels of highly toxic elements like cadmium and arsenic. According to the findings, it is found that the As content in rice does not significantly differ among climatic zones and rice types while Se content is differs among rice types. But the Cd content differs drastically with rice type and climate zone. Based on that results, they have concluded that the elevated levels of toxic elements such as Cd and As in rice may be due to high input of anthropogenic contaminants such as fertilizer applications since the geogenic input is not considerable in Sri Lanka. Although the Selenium (Se) is one of the most important element in human body that should contain in the diet has been identified as a deficient element among the Sri Lankans. Higher amount of Se content has been reported in native rice varieties. Further, it is clear that applying chemical fertilizers is strengthening the mineral contents (Ca, Mg, Mn, and Zn) of rice kernels and brans of selected Sri Lankan newly improved rice varieties (Kariyawasam *et al.*, 2016).

However, nutritional properties and physicochemical properties of improved rice varieties also have been investigated along with traditional rice varieties. Hafeel *et al.*, (2020) showed that there was no significant difference in physicochemical properties such as gelatinization temperature (GT) and amylose content (AC) along with proximate composition in traditional varieties over improved varieties except protein content. In this research also they have found that the pericarp colour does not influence the parameters. It is observed that improved varieties as H4, H7, and Bw 272-6b contain more than 9% of protein content higher than that of other tested varieties. Rice varieties with low amylose content show a higher amount of ash. Most of the improved rice varieties exhibit higher protein content and varieties with higher fat content reveal generally higher ash content. It is found that GI of improved 'At' varieties is in range from low to medium and influence of the degree of polishing on GI was variety dependent (Hafeel *et al.*, 2016).

#### 4. CONCLUSION

According to the research findings, most of the studies revealed that the health benefit of Sri Lankan traditional rice varieties. Most of the studies have shown that the importance of consumption of traditional rice varieties than that of improved varieties for patients suffering from non-communicable diseases. Glycemic Index (GI) of rice is the main factor when determining suitability of rice for consumption in diabetes mellitus. Identification and popularizing rice varieties with low GI values is in utmost important. Absents of proper identification method and naming system for traditional rice varieties in Sri Lanka has been observed. Classification of varieties based on their nutritional quality is very much important as rice is the primary source of most of the nutrients in Sri Lankan hence most of the nutrient deficiencies can be fulfil through rice. According to the referred literature it is clear that the nutritional quality and physicochemical properties are greatly affected on varietal differences, agronomic practices such as fertilizer application, soil factors, weed and pest control methods and etc. Moreover, mineral content of rice is important as the major source of most of the major and minor

nutrient is rice in most of the Sri Lankan. There are large number of traditional varieties which are not investigated for their nutritional parameters yet. Traditional varieties can be easily grown under organic cultivation to get higher yield with good nutritional characteristics although the improved varieties are largely depending on chemical fertilizers. But, further investigations are required to be conducted on health effects, proximate composition, agronomy, and the consumer demand of traditional varieties as well as improved varieties in Sri Lanka.

## REFERENCES

- Abeysekera, W.K.S.M., Arachchige, S.P.G., Ratnasooriya, W.D., Chandrasekharan, N.V. and Bentota, A.P., (2017). Physicochemical and nutritional properties of twenty three traditional rice (*Oryza sativa* L.) varieties of Sri Lanka. *Journal of Coastal Life Medicine*, 5(8), pp.343-349.
- Abeysekera, W.K.S.M., Arachchige, S.P.G., Ratnasooriya, W.D., Choudhary, M.I., Dalvandi, K. and Chandrasekharan, N.V., (2015). Anti-diabetic related health food properties of traditional rice (*Oryza sativa* L.) in Sri Lanka. *Journal of Coastal Life Medicine*, 3(10), pp.815-820.
- Diyabalanage, S., Navarathna, T., Abeyesundara, H.T., Rajapakse, S. and Chandrajith, R., (2016). Trace elements in native and improved paddy rice from different climatic regions of Sri Lanka: implications for public health. *SpringerPlus*, 5(1), pp.1-10.
- Fresco, L., (2005). Rice is life. *Journal of Food Composition and Analysis*, 4(18), pp.249-253.
- Gunaratne, A. et al. (2011) 'Functional, digestibility, and antioxidant properties of brown and polished rice flour from traditional and new-improved varieties grown in Sri Lanka', *Starch-Stärke*, 63(8), pp. 485-492.
- Gunaratne, A., Wu, K., Li, D., Bentota, A., Corke, H. and Cai, Y.Z., (2013). Antioxidant activity and nutritional quality of traditional red-grained rice varieties containing proanthocyanidins. *Food chemistry*, 138(2-3), pp.1153-1161.
- Hafeel, R.F., Amararathna, L.B.A.P., Chamintha, T.H.T., et al. (2016). Glycemic index of improved rice varieties as influenced by degree of polishing and proximate composition including amylose content. *Tropical Agriculturist*, 164, pp.83-96.
- Hafeel, R.F., Bulugahapitiya, V.P., de Zoysa, G.E.D. and Bentota, A.P., (2020). Variation in Physicochemical Properties and Proximate Composition of Improved and Traditional Varieties of Rice in Sri Lanka. *Journal of Food and Agriculture*, 13(1), pp.19-32.
- Juliano, B.O., (1993). *Rice in human nutrition* (No. 26). Int. Rice Res. Inst.
- Kariyawasam, T.I., Godakumbura, P.I., Prashantha, M.A.B. and Premakumara, G.A.S., (2016). Proximate composition, calorie content and heavy metals (As, Cd, Pb) of selected Sri Lankan traditional rice (*Oryza sativa* L.) varieties. *Procedia food science*, 6, pp.253-256.
- Panlasigui, L.N., Thompson, L.U., Juliano, B.O., Perez, C.M., Yiu, S.H. and Greengerg, G.R. (2018) 'Rice varieties with similar amylose digestibility and glycemic response content differ in starch in humans13', (March). Available at: <https://pubmed.ncbi.nlm.nih.gov/1951159/>
- Pathiraje, P.M.H.D., Madhujith, W.M.T., Chandrasekara, A. and Nissanka, S.P., 2010. The effect of rice variety and parboiling on in vivo glycemic response.
- Prasanth, B.D.R., (2018). Glycemic index of four traditional red pigmented rice. *Integr. Food Nutr. Metab*, 5, pp.1-3.
- Premakumara, G.A.S., Abeysekera, W.K.S.M., Ratnasooriya, W.D., Chandrasekharan, N.V. and Bentota, A.P., (2013). Antioxidant, anti-amylase and anti-glycation potential of brans of some Sri Lankan traditional and improved rice (*Oryza sativa* L.) varieties. *Journal of cereal science*, 58(3), pp.451-456.
- Rambukwella, R. and Priyankara, E.A.C., 2016. *Production and marketing of traditional rice varieties in selected districts in Sri Lanka: Present status and future prospects*. Hector Kobbekaduwa Agrarian Research and Training Institute.
- Samaranayake, M.D.W., Yathursan, S., Abeysekera, W.K.S.M. and Herath, H.M.T., (2017). Nutritional and antioxidant properties of selected traditional rice (*Oryza sativa* L.) varieties of Sri Lanka. *Sri Lankan Journal of Biology*, 2(2).
- Sompong, R., Siebenhandl-Ehn, S., Linsberger-Martin, G. and Berghofer, E., (2011). Physicochemical and antioxidative properties of red and black rice varieties from Thailand, China and Sri Lanka. *Food chemistry*, 124(1), pp.132-140.

- Thushara, P., Godakumbura, P. and Prashantha, B., (2019). Importance, Health Benefits and Bioactivities of Sri Lankan Traditional Rice (*Oryza sativa* L.) Varieties: A Review. *International Journal of Agriculture Environment and Bioresearch*, 4, pp.119-128.
- Thushara, P.A.N., Godakumbura, P.I. and Prashantha, M.A.B., (2020). Agronomic Characters and Chemical composition of Sri Lankan Novel Red Pericarp Rice (*Oryza sativa* L.) Variety. *International Journal of Environment, Agriculture and Biotechnology*, 5(2).
- Verma, D. K. et al. (2015) 'Physico-chemical and cooking characteristics of Azad basmati', *International Food Research Journal*, 22(4), pp. 1380–1389.
- Verma, D.K. and Srivastav, P.P., (2017). Proximate composition, mineral content and fatty acids analyses of aromatic and non-aromatic Indian rice. *Rice Science*, 24(1), pp.21-31.
- Verma, D.K., Mohan, M., Prabhakar, P.K. and Srivastav, P.P., (2015). Physico-chemical and cooking characteristics of Azad basmati. *International Food Research Journal*, 22(4), p.1380.

# Development and Evaluation of Orange Flavoured Fermented Buttermilk

S. D. D. N. Indrajith\*, C. J. Abeywickrama

Department of Agriculture and Food Technology, University of Vocational Technology, Sri Lanka

## ABSTRACT

*Buttermilk is an excellent source of essential nutrients and health promoting constituents. However, major part of buttermilk is removed as waste in Sri Lanka due to unpleasant flavor and low total solids. Thus, this study focused on developing buttermilk based fermented beverage to enhance the utilization. Different proportions of concentrated orange pulp (3.5%, 4.5% and 5.5%) and sugar (1.45%, 3.45% and 5.45%) were added to fermented buttermilk. Sensory attributes and overall acceptability were measured separately using thirty (30) semi trained panelists with five (5) points hedonic scale and concentrated orange pulp to sugar at 1:1 ratio was selected as the best formula through statistical analysis (MINITAB-14 version at 0.05 significant levels). The best selected formulation was further analyzed for physiochemical (pH and viscosity) and nutrient properties. Microbial count was evaluated once a week. Organoleptic characteristics were observed up to 7 weeks of shelf life storage period. The relationship between pH and viscosity was observed without adding stabilizer or emulsifier to the product. The value-added fermented buttermilk beverage with frozen concentrated orange pulp can be improved in promoting health quality as low fat and low sugar.*

**Keywords:** *Buttermilk, Fermented, Flavor, Enhance, Utilization.*

## 1. INTRODUCTION

Buttermilk is a by-product in the dairy industry, which contains low total solid 9.6% and fat 0.9%. The buttermilk is derived from the production of butter production and contains milk fat membrane (MFGM), lactose, proteins, minerals and lecithin (Sodini et al., 2006). Particularly high scientific interest is focused on the strength because of its unique composition, the components of high biological value are released from the fat globules of milk destroyed during butter churning. MFGM contains bioactive compounds that have positive health effects such as tumor or cholesterol-lowering effects (Barukčić et al., 2019) and prevent *Helicobacter pylori* or gastrointestinal infections. However, major part of buttermilk is removed as waste in the milk industry of Sri Lanka. Various technological solutions have been studied in order to increase the production of milk-based foods as the production of beverages appears to be the most economically and technologically acceptable. Casein and the large amounts of phospholipids available in yoghurt have good emulsifying properties suitable for wide use in the food industry. The purpose of this study was to utilize the buttermilk through the development of beverage product by fermentation and addition of natural orange flavor.

## 2. METHODOLOGY

### 2.1. Preparation of Buttermilk

Buttermilk was collected through the churning of uncultured cream from the butter production. The collected buttermilk was stored at  $4 \pm 2$  °C in the stainless- steel buckets. Ten samples of Buttermilk were collected from every ten days of the butter productions to determine fat% and total solid% (TS%) using Gerber butyrometer method. SLS: 735: Part 6: 1989 and DSLS 181 respectively.

---

\* Corresponding Author: Email - [diindrajith@gmail.com](mailto:diindrajith@gmail.com)



## 2.2 Preparation of the Orange Flavoured Fermented Buttermilk Beverage

Sweet buttermilk (86.17% w/w) (0.9% fat and 9.6% TS%) was heated up to 90 °C for 5 minutes and sugar (F1-6.9%, F2-5.45%, F3-3.45%, F4-1.45% w/w) was added in the heated buttermilk at 60 °C. Then homogenized the mixture using high shear mixture 80 rpm for 20 minutes. Then cooled down at 42 °C, after added starter culture (0.02%) and stirred well. After incubated up to pH 4.6 - 4.65, cooled ( $8 \pm 2$  °C) and was breaking the curd. Orange frozen concentrated pulp (F1-6.9%, F2-5.5%, F3-4.5%, F4-3.5% w/w) and orange emulsion flavour (0.03% w/w) were added and mixed well. Then the fermented buttermilk beverage was filled in to the sterilized plastic transparent bottles (200 mL). After these beverages were stored at  $4 \pm 2$  °C.

## 2.3 Sensory Evaluation

Untrained panel of 30 members were representing different age groups (age 25-50 years) for the sensory panelists. The temperature of the beverage before the test was  $18 \pm 2$  °C, and samples with a volume of approximately 30 ml were presented to the assessors in plastic cups with a volume of 50 mL, coded with three numeric digits. The results obtained by the hedonic test were analyzed using the Friedman test, non-parametric analysis was performed using the MINITAB version 17. For the sensory evaluation, organoleptic attributes regard to appearance/ colour, Aroma, texture/mouth feel, orange taste, sweetness and overall acceptability of all four samples were assessed using a 5-point hedonistic scale (where 5 was equally to like very much and 1 was equally dislike very much) and a descriptive testing method.

## 2.4. Physiochemical Analysis

### 2.4.1. Determination of Viscosity

Viscosity was determined using Brookfield Ammeter DV-1 Viscometer at  $19.2 \pm 0.2$  °C. Viscosity 27 s<sup>-1</sup> was recorded at a distortion rate from RV-02 spindle.

### 2.4.2. DETERMINATION OF PH VALUE

pH was determined using a pH meter preferably with a glass electrode. SLS 824: Part 2 / Appendix C.1: 2018.

## 2.5. Nutritional Analysis

### 2.5.1. Determination of Protein

Protein content was determined by using SLS 735: Part 7 / Section 4: 2017. The test sample was warmed to between 38 °C to 40 °C in the water bath. After the sample was cooled to room temperature. Then, a 5.0 mL volume of the prepared test sample was transferred to a Kjeldahl flask. To the Kjeldahl flask was added 40 mL of trichloroacetic acid solution and swirled to mix the contents. The flask was allowed to stand for 5 minutes to allow the precipitate to settle. The competition of the flask was poured over filter paper placed in a filter funnel. The filtrate was collected into a conical flask. Potassium sulfate, copper catalyst solution and sulfuric acid were added to the filtrate and was continued with the digestion and distillation procedure. The solution was titrated using ammonia. Readings was got for the blank titration.

### 2.5.2. Determination of Total Sugar

Total sugar was determined using SLS 735: Part 6: 1989. The beverage sample (40 g) was weighed to the nearest mg and transferred into the beaker. 50 mL of distilled water was added at 80 °C to 90 °C. The mix was transferred into the 200 mL volumetric flask and was added distilled water at 60 °C until volume was between 120 mL to 150 mL. The solution was cooled to room temperature and was added 5 mL of ammonia solution. Then the solution is mixed again and let stand for 15 minutes. Adequate amounts of acetic acid were then added and re-mixed to neutralize the ammonia. Then 12.5 mL each of zinc acetate and potassium ferrocyanide solution was added and cooled to room temperature. The solution was then prepared with distilled water up to 200 mL mark. After standing for a few minutes, it

was filtered through dry filter paper. The filter was weighed (1). 40 mL of the filtrate was transferred to a 50 mL volumetric flask and 6 ml of hydrochloric acid. The entire flask was then placed in a water bath maintained at 60 ° C for 12 minutes and cooled to room temperature. Then dilute to 50 mL with distilled water, mix and let stand for 1 hour. The solution is then filtered through dry filter paper and the filtrate (2) is weighed.

### 2.5.3. Determination of Fat

Fat was determined using Gerber butyrometer method. SLS 735: Part 6: 1989. The milk in the sample bottle was heated to 20°C and mixed well with a gentle vibration. 10 mL of sulfuric acid was added to the butyrometer without wetting the neck of the butyrometer. 10.00 mL of milk was transferred to a butyrometer. Then pour 1 mL of amyl alcohol into the milk with a pipette. Closed with a stopper without stirring the butyrometers. The butyrometer turned on the bulb and bought a butyrometer tube. The butyrometer was shaken vigorously using two. The butyrometer was shaken and turned upside down a few minutes. Then the butyrometer was placed inside the Gerber centrifuge, whereby the butyrometer must be places exactly opposite each other. After setting the centrifuge time, then started the centrifuge. After reaching a centrifugal force of (350 ± 50) g. As a general rule, if you reach after 1 minute, you should maintain the corresponding speed (1100 ± 50) rpm for 4 minutes. After removing the butyrometer from the centrifuge, the meniscus of the fat column should be held vertically at eye level.

## 2.6. Microbiological Analysis

### 2.6.1. The Enumeration of Yeast & Moulds

Reference standard – SLS 1558 part 2 / Section 1: 2017.Culture Medium: Yeast Extract Dextrose Chloramphenicol Agar; method: Pour Plate Method. 1ml of the sample was transferred in to each of two sterile petri dishes through the pipette. Immediately 15-20 mL of sterile oxytetra-glucose yeast agar (OGYE) medium was added to each dish that had been previously melted and cooled to about 45 °C. Cover the petri dishes and immediately mix the sample with the medium by rotating clockwise and counter clockwise. Clockwise is to obtain evenly dispersed colonies after incubation and allow the agar to solidify at room temperature. Petri dishes were inverted and incubated in 20 °C to 25 °C for at least 5 days. The plates were inspected after proper incubation for the presence of colonies, often using a colony counter.

### 2.6.2. The Enumeration of Coliforms

Reference Standard – SLS 516 Part 3 / Section 2 : 2013.Culture Medium: Crystal Violet Neutral Red Bile Lactose Agar; method: Pour Plate Method. 1mL of the sample was transferred in to each of two sterile petri dishes through the pipette. 15-20 mL of sterile crystal violet neutral red bile lactose agar medium was rapidly added to each dish that had been pre-dissolved and cooled to approximately 45 ° C. On a Petri dish, rotate both clockwise and counterclockwise to mix the sample immediately with the medium to obtain uniformly dispersed colonies after incubation and allow the agar to solidify at room temperature. The Petri dish was turned upside down and incubated at 30 °C to 35 °C for at least 1 day. The plates were examined after proper incubation for the presence of colonies, preferably using a colony counter.

### 2.6.3. The Enumeration of *Escherichia Coli*

Reference Standard – SLS 1558: Part 2 / Section 1: 2017. 1ml of the sample was transferred on to *E.coli* petri film through the pipette. The sample was spread on the petri film. Incubated at 30°C - 35°C for 1 day. The product complies with the test if blue green colour colonies are present. Growth of colonies indicates the possible presence of *E.coli*. The petri film was examined after proper incubation for the presence of colonies.



Figure 1: Orange flavoured fermented buttermilk

### 3. RESULTS AND DISCUSSION

#### 3.1. Sensory Evaluation

Table 1 reveals higher value for overall acceptability as 4.5, 3.5, 3.5 and 3.5 for F1, F2, F3 and F4 respectively. F1 was highly accepted for its orange taste, mouth feel/ texture and overall acceptability whereas F2 highest score observed only for appearance/ colour and F3 highest score observed only for sweetness. For the orange taste and sweetness, lowest value observed for F4 and F1 respectively. All the samples were in same scored for aroma.

Table 1: Estimate median values of sensory attributes of Orange flavoured fermented buttermilk

Attributes	F1	F2	F3	F4
Appearance / Colour	3.1250	4.8750	3.3750	3.1250
Aroma	3.0000	3.0000	3.0000	3.0000
Orange Taste	4.5630	3.8130	4.1880	2.1880
Sweetness	2.1250	4.0000	5.0000	3.8750
Mouth feel / Texture	4.7500	3.2500	3.0000	3.0000
Overall Acceptability	4.5000	3.5000	3.5000	3.5000

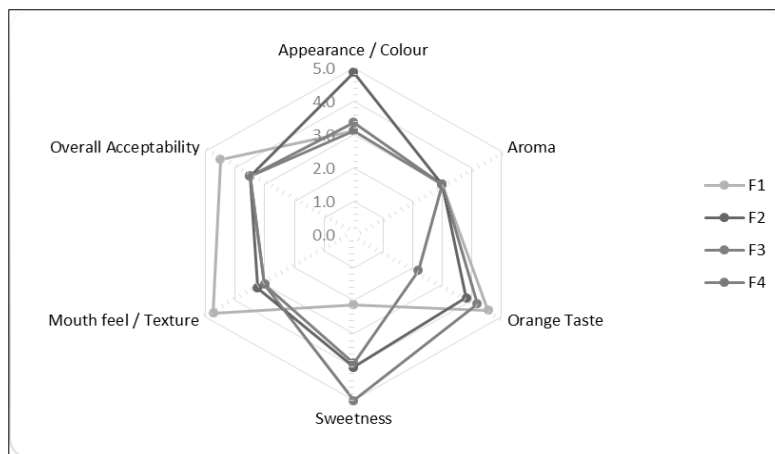

Figure 2: Pattern of variation of sensory attributes of orange flavoured fermented buttermilk

### 3.2. Physiochemical Parameters

The viscosity content determined in the selected value added fermented buttermilk beverage ( $183.7 \pm 11.58\%$ ); this value was slightly changed during the shelf-life. Viscosity value was represented the texture of the beverage. In an attempt to determine the amount of viscosity in cultured buttermilk most acceptable from the consumer standpoint and increased acidities resulted in an increase of the viscosity of the cultured buttermilk (Schock et al., 1948).

The pH of the value added fermented buttermilk was  $4.05 \pm 0.31$ . This beverage can be classified as a high acid food ( $< \text{pH } 4.6$ ). The determination of pH is important for determinant of microbial growth and consumer preference.

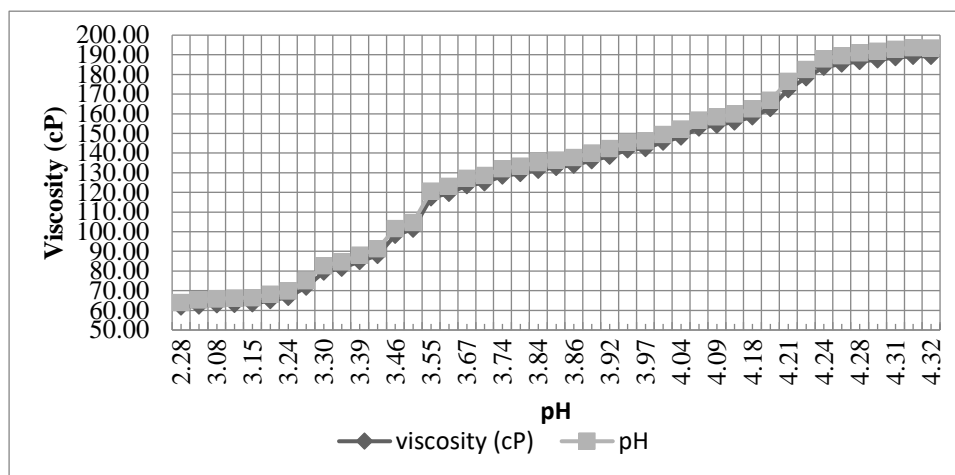

Figure 3: Relationship between pH and viscosity

### 3.3. Nutrient Analysis

The selected value added fermented buttermilk beverage was analyzed for their physiochemical parameters and nutrient contents and the data is represented in Table 2.

Table 2: Physiochemical and nutrient properties of Orange flavoured fermented buttermilk

Physiochemical parameters	Result
Protein	$5.40 \pm 0.4\%$
Fat	$0.85 \pm 0.05\%$
Total sugar	$6.30 \pm 0.3\%$
pH	$4.05 \pm 0.31$
Viscosity	$183.7 \pm 11.58\%$

### 3.4. Microbial Analysis

The Results obtained from Microbiological evaluation of the value added fermented buttermilk beverage are presented in Table 3. The sample was evaluated once a week. The amount of colonies of yeast and mould and *Coli form* count had in the lowest level according to the SLS 824 (Part II 1989) for cow milk base product the permissible level is  $< 1000 \text{ CFU/g}$ . Therefore, the product has a safety level for consumption up to 15 days at  $4 \pm 2^\circ\text{C}$  storage.

Table 3: Total Microbial Count

Microbial count (cfu / mL)	Yeast & Mould	Coliform	E-coli
1 <sup>st</sup> day	Not detected	Not detected	Not detected
8 <sup>th</sup> day	Not detected	Not detected	Not detected
15 <sup>th</sup> day	2	Not detected	Not detected

#### 4. CONCLUSION

The Formulation with treatment one (buttermilk 86.17%, Sugar 6.90%, Orange pulp 6.90%, Flavour Orange Emulsion 0.03%) was preferred by the panelists in the sensory analysis. This treatment exhibited the best sensory attributes. The nutritional analysis was done and protein, total sugar, fat, viscosity and pH results were  $5.40 \pm 0.4\%$ ,  $0.85 \pm 0.05\%$ ,  $6.30 \pm 0.3\%$ ,  $4.05 \pm 0.31$ ,  $183.7 \pm 11.58\%$  respectively.

From the above results it may be introduced that the low fat and high acid value added fermented buttermilk beverage. Buttermilk use more than 85% as the main ingredient that is helped to reduce of wastage of buttermilk. Buttermilk based fermented beverages that are delightful to the consumer.

According to quality characteristics of final product it can be concluded that the basic objectives of the project were achieved.

#### REFERENCES

- Marc R. Bachmann, Winterthur, Switzerland; Endel Karmas, Kendall Park, N.J., inventors; Rutgers, The State University of New Jersey, New Brunswick, N.J. Novel cultured buttermilk compositions and method of preparation. United States patent US 4,748,025. 1988 May 31.
- Barukčić, I., Lisak Jakopović, K. and Božanić, R., (2019). Valorisation of whey and buttermilk for production of functional beverages—an overview of current possibilities. *Food technology and biotechnology*, 57(4), pp.448-460.
- Gebreselassie, N., Abrahamsen, R.K., Beyene, F., Abay, F. and Narvhus, J.A., (2016). Chemical composition of naturally fermented buttermilk. *International Journal of dairy technology*, 69(2), pp.200-208.
- Glenn, W.E. and Prouty, C.C., (1955). Bacteriological Studies of Cultured Buttermilk: III. The Effect of Additions of Citric Acid, Sodium Citrate and Lactic Acid on the Progressive Changes in the Numbers of *Leuconostoc citrovorum* and *Streptococcus cremoris* as Associated with Acetylmethylcarbinol plus Biacetyl and pH Levels. *Applied microbiology*, 3(6), pp.317-320.
- Libudzisz, Z., Stepaniak, L. (2002). *Encyclopedia of Dairy Sciences (Second Edition)*. Academic Press, pp.489-495.
- Liutkevičius, A., Speičienė, V., Alenčikienė, G., Miežilienė, A.L.D.O.N.A., Narkevičius, R., Kaminskas, A., Abaravičius, J.A., Vitkus, D., Jablonskienė, V. and Sekmokienė, D., (2016). Fermented buttermilk-based beverage: impact on young volunteers' health parameters. *Czech Journal of Food Sciences*, 34(2), pp.143-148.
- Schock, A.A. and Breazeale, D.F., (1948). *Cultured Buttermilk from Non-Fat Dry Milk Solids*.
- Sheth, M. and Hirdyani, H., (2016). Development and sensory analysis of a buttermilk based fermented drink using barley and fructooligosaccharide as functional ingredients. *International Journal of Home Science*, 2, pp.235-239.
- Palthur, S., Anuradha, C.M. and Devanna, N., (2014). Development and Evaluation of Cinnamon Flavored Buttermilk. *Frontiers in Food & Nutrition Res.*
- Sodini, I., Morin, P., Olabi, A. and Jiménez-Flores, R., (2006). Compositional and functional properties of buttermilk: A comparison between sweet, sour, and whey buttermilk. *Journal of Dairy Science*, 89(2), pp.525-536.
- Szkolnicka, K., Dmytrów, I. and Mituniewicz-Małek, A., (2020). Buttermilk ice cream—New method for buttermilk utilization. *Food science & nutrition*, 8(3), pp.1461-1470.

# Development of a Colour-Based Quality Analysis Tool for Sri Lankan Bee Honey

O.W.S. Madusanka<sup>1</sup>, P.P.A.J. Rathnayake<sup>2\*</sup>, G.M. Somaratne<sup>1</sup>, D.H. Beligala<sup>3</sup>, G.G.R. Wimukthi<sup>4</sup>

<sup>1</sup> Department of Food Science and Technology, Faculty of Agriculture, University of Peradeniya, Sri Lanka

<sup>2</sup> Division of Applied and Natural Sciences, University College of Matara, Sri Lanka

<sup>3</sup> Department of Molecular Biology and Biotechnology, University of Peradeniya, Sri Lanka,

<sup>4</sup> Beekeeping Development Unit, Department of Agriculture, Bindunuwewa, Bandarawela, Sri Lanka.

## ABSTRACT

*Lack of quality assessment techniques has negatively impacted beekeeping in Sri Lanka. This study aimed to develop a colour-based quality analysis toolkit for Sri Lankan beekeepers. Bee honey samples were collected from different geographical locations, and they showed a wide variability in microstructure and physicochemical properties. Bee honey colour was evaluated in terms of lightness ( $L^*$ ), redness ( $a^*$ ), and yellowness ( $b^*$ ). The obtained  $L^*a^*b^*$  colour values were re-synthesised using a colour converter software (DATACOLOR Tools Plus) and the standard set of circular colour cards were printed for each geographical location. Then a bee honey colour analysis toolbox was designed. The printed standard colour cards and the unknown bee honey sample could be loaded into the standard colour card chamber and the unknown sample chamber of the toolbox, respectively. With the help of the light source, the evaluator could assess the colour quality of the unknown sample compared to the standard. The developed colour analysis toolkit is inexpensive, portable, and versatile compared to the laboratory colour analyser. Even though this colour analysis toolkit needs further improvements, it can be used to identify the floral origin, geographical location, harvesting season, and any type of inferior quality or adulterations of bee honey.*

**Keywords:** Bee honey; Beekeepers; Colour converter software;  $L^* a^* b^*$  values; Microstructure.

## 1. INTRODUCTION

Honey is a sweet product produced by honeybees by using plant nectar (blossom honey), secretions of living parts of plants, or excretions of plant-sucking insects on the living parts of plants (honey-dew honey) (Jayasinghe *et al.*, 2012; Lewkowski *et al.*, 2019). Physicochemical properties of bee honey depend on its geographical floral origin, season, environmental factors, and beekeeping practices (Jayasinghe *et al.*, 2012; Silva *et al.*, 2018). Bee honey is a non-allergic food that human body easily assimilates, and it is highly used as a natural sweetener and food preservative ingredient (Lewkowski *et al.*, 2019). Additionally, bee honey is a complex mixture of bioactive compounds including aromatic substances, polyphenols, and pigments. Honey is a functional food, which is consumed for its beneficial effects on human health. These effects, that can be attributed to its unique composition, include antibacterial, antioxidant, anti-inflammatory, and antimicrobial properties, sun burn and wound healing properties and cosmetic properties (Ediriweera and Premarathna, 2012; Cornara *et al.*, 2017; Saranraj & Sivasakthi, 2018). Honey has been subjected to adulteration mainly with low-cost sugars such as sugar cane and sugar beet and commercial syrups such as corn syrup, glucose syrup, sucrose syrup, inverted syrup, and high fructose inulin syrup (Jayasinghe *et al.*, 2012; Fakhlai *et al.*, 2020). Adulteration of honey alters the physicochemical and medicinal properties of honey, such as enzymatic activity, antioxidant capacity and electrical conductivity. Moreover, certain adulterants can cause adverse health effects to the consumers (Anthony and Balasuriya, 2016; Fakhlai *et al.*, 2020).

There are more than 20,000 of winged insects that have been identified as bee species which grouped as Family Apidae, superfamily Apoidea and the order Hymenoptera (Peters *et al.* 2017). There are about 295,383 species of flowering plants existing in the world (Christenhusz and Byng, 2016). About 75%

---

\* Corresponding Author: Email - [pasanr@ucm.ac.lk](mailto:pasanr@ucm.ac.lk)

of flowering plants and about 35% of the world's food crops depend on animal pollination for reproduction and evolution. Among animal pollinators, bees have specialized lifestyles and adaptations to live on flowers and provides highly valued pollination services for a wide variety of agricultural crops (Calderone, 2012).

Beekeeping is a cultural heritage in Sri Lankan community, practised since ancient times as honey hunting dates back to thousands of years (Jayasinghe *et al.*, 2012). There is an increasing demand for the Sri Lankan honey in the international market especially based on the honeybee species floral sources (Silva *et al.*, 2018). Beekeeping can be started with low investment, so that, even low-income people can go for it with little support. Thus, beekeeping paves the path to self-employment for poor and rural people, leading to poverty eradication (Ediriweera and Premarathna, 2012; Jayasinghe *et al.*, 2012). Moreover, some Sri Lankan government agencies and several foreign agencies are actively promoting beekeeping for the development of livelihood of deprived communities in rural areas. However, beekeeping has been hindered due to lack of modern beekeeping technology, improper management of colonies, and lack of techniques for assessing the quality of bee honey (Punchihewa, 1994; Jayasinghe *et al.*, 2012). Thus, further research should focus on studying honeybee diversity, low-cost honey production technologies with proper quality assessment, preserving the expected quality and safety of bee honey, and appropriate authentication techniques of bee honey.

Colour is one of the major quality parameters of bee honey which can be used to identify the consumer preference, floral origin, geographical location, and the harvesting season of bee honey (Belay *et al.*, 2015; Boussaid *et al.*, 2018). At the same time, colour standards of bee honey can be employed in identifying inferior qualities and adulterations in honey (Boussaid *et al.*, 2018). In Sri Lanka, one of the major constraints faced by the beekeepers is the lack of colour analysis equipment for an affordable price. As a result, the local beekeepers mainly rely on traditional methods of colour analysis and their experience that are not ensured to provide reliable results. Therefore, the overall intention of this research is to develop a colour analysis tool that could help bee honey producers to understand the colour distribution of their bee honey, authenticity, and its geographical origin.

## 2. MATERIAL AND METHODS

### 2.1 Collection of Bee Honey Samples

Bee honey samples were obtained in April season, 2021, from the Beekeeping Development Unit of the Department of Agriculture, Sri Lanka, and its approved local beekeepers with a guarantee of genuineness. These included six bee honey samples from different areas in Sri Lanka which mainly contributed to the bee honey industry (Table 1). All the samples were stored in sterile airtight glass containers covered with aluminium foil. They were stored in refrigerated conditions (7°C) until further analysis.

Table 1: Geographical locations of the collected bee honey samples

No. of Bee Honey Sample	Geographical Location	District, Agroecological Zone
1	Udubumbara	Kandy, Mid country- intermediate zone
2	Anuradhapura	Anuradhapura, Low country- dry zone
3	Bibila	Monaragala, Low country- intermediate zone
4	Bandarawela	Badulla, Up country- intermediate zone
5	Welimada	Badulla, Up country- intermediate zone
6	Jaffna	Jaffna, Low country- dry zone

## 2.2 Microscopic Analysis of Honey Samples

Initially, the honey samples were mixed well using a clean glass rod. Then one or two drops of honey were transferred on to a clean glass slide which was then covered with a clean lid to ensure the even distribution. Next, the prepared sample was observed under the compound light microscope (400X) (Nikon Instruments Inc., Japan).

## 2.3 Determination of Ph

The pH of a 10% (w/v) solution of honey prepared in distilled water was measured using a calibrated laboratory pH meter (EXTECH Ph100, China) as described in El-Sohaimy *et al.*, (2015).

## 2.4 Determination of Moisture Content

Moisture content was determined according to the method described in the SLS standard (SLSI 464:1979-Bee honey). Briefly, the moisture content was determined from the refractive index of the honey using a digital refractometer (ATAGO PAL-3, Japan). The method is based on the principle that refractive index of the honey increases with total soluble solid (TSS) content. The refractive index of the sample was determined at a constant temperature near 20 °C. The mean refractive index was then converted to moisture content as described in El-Sohaimy *et al.*, (2015).

## 2.5 Determination of Water Activity ( $A_w$ )

Determination of water activity was done according to the method described by Zamora *et al.*, (2006). The water activity of bee honey was determined at 25 °C using an electronic dew-point water activity device (Rotronic HygroLab, Switzerland) equipped with a temperature-controlled system which allows to have a temperature stable sampling environment. The equipment was calibrated with saturated salt solutions in the water activity range of 0.43 – 0.75.

## 2.6 Colour Analysis

Colour was measured using a colorimeter (CHN Spec CS-10, China) as described by Szabó *et al.*, (2016). Briefly, homogeneous honey samples devoid of air bubbles were transferred into a cuvette and the cuvette was inserted into the colorimeter and the resulting L (Lightness), a (greenness) and b (yellowness) were recorded for each sample. As the major output of the research, a colour analysis toolkit was developed with the obtained  $L^*a^*b$  colour values and more details about this methodological and instrumental development are given in the “results and discussion” section.

## 2.7 Statistical Analysis

All analyses of physicochemical parameters were carried out in triplicate and the data were expressed as mean standard deviations (SD). Analysis of variance (ANOVA) was used to compare the quantified variables in honey samples. The significance was calculated for  $P < 0.05$ . The statistical analyses were performed with the SPSS Statistic.

# 3. RESULTS AND DISCUSSION

## 3.1 Microscopic View of Bee Honey

Microscopic profile is unique in natural honeybee derived from different geographical origins (Figure 1a-f). Pollens were clearly visible in the bee honey samples. Anuradhapura sample shows an observable mesh structure of honey which could be due to crystallization of sugar in bee honey. Previous research reported that authentic bee honey mainly contains pollen grains which is a part of the flower collected by honeybees (Silva *et al.*, 2018).



### 3.2 Physicochemical Quality Characteristics of Bee Honey

Physicochemical quality parameters of bee honey samples obtained in this study including TSS (%), moisture content (%), water activity ( $a_w$ ) and pH are given in Table 2. In Sri Lankan bee honey samples, the moisture content ranged from 23 to 36% while the TSS content ranged from 64 to 76%. According to the SLSI standards, the maximum TSS (%) in bee honey is around 75% and moisture is 25%. The significant variability in the moisture content of honey samples can be attributed to different environmental conditions such as climate, floral origin of honey samples, water content of nectars, processing techniques, and storage conditions. A comparatively higher moisture content was observed in honey obtained from Bandarawela and that could be due to reported higher humidity in the Bandarawela area. The results of the analysis of variance (Table 2) show that the TSS (%) varies significantly according to the zones. Results revealed that TSS values were significantly higher in Ududumbara and Bibila areas whereas lower values were obtained for Bandarawela zone.

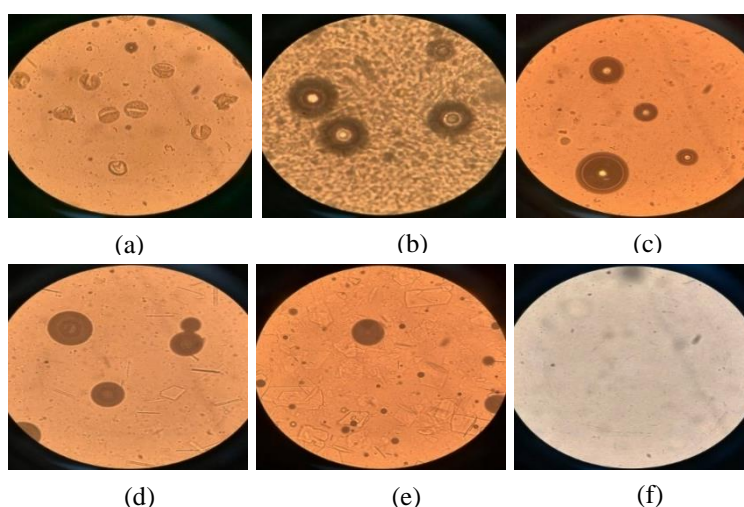

Figure 1: Microscopic view of bee honey (400 $\times$ ) originated from (a) Jaffna, (b) Anuradapura, (c) Bandarawela, (d) Welimada, (e) Ududumbara and (f) Bibila.

Water activity is a critical factor that affects food spoilage by microorganisms (Tapia *et al.*, 2020). Average water activity of bee honey is  $0.253 \pm 0.006$  and water activity of samples ranged between 0.24 and 0.26 in analysed samples. Bee honey reported a low water activity compared to minimum values of water activity for microbial growth which are 0.91 for Bacteria, 0.85 for Yeast, 0.8 for Moulds (Tapia *et al.*, 2020). Consequently, bee honey is a shelf-stable safe sweetener which restricts the harmful and pathogenic microbial growth in honey. The pH values of the analysed samples ranged within acidic pH from 3.78 to 4.67 (Table 2).

Table 2: Physicochemical quality characteristics of bee honey in the six geographical regions in Sri Lanka

Sample	Moisture (%)	TSS (%)	Water Activity	pH
Ududumbara	$23.36 \pm 0.11^a$	$76.63 \pm 0.11^a$	$0.2454 \pm 0^a$	$4.43 \pm 0.09^a$
Anuradhapura	$23.76 \pm 0.15^b$	$76.23 \pm 0.15^b$	$0.2489 \pm 0^b$	$3.77 \pm 0.03^b$
Bibila	$23.40 \pm 0.20^a$	$76.60 \pm 0.20^a$	$0.2506 \pm 0^b$	$4.04 \pm 0.01^c$
Bandarawela <sup>(a)</sup>	$36.00 \pm 0.10^c$	$64.00 \pm 0.10^c$	$0.2630 \pm 0^c$	$4.39 \pm 0.01^a$
Welimada	$24.23 \pm 0.32^d$	$75.76 \pm 0.32^d$	$0.2587 \pm 0^d$	$4.32 \pm 0.02^a$
Jaffna	$25.16 \pm 0.25^e$	$74.83 \pm 0.25^e$	$0.2568 \pm 0^d$	$4.16 \pm 0.06^d$

The acidity of bee honey is mainly due to the presence of organic acids, particularly the gluconic acid and inorganic ions such as phosphate and chloride. Moreover, pH values of all the samples fell within 3.40 – 6.10, which is the accepted range according to the Codex Alimentarius criteria. This was a good indicator of honey freshness (El-Sohaimy *et al.*, (2015).

All values are given as the mean of triplicates  $\pm$  Standard Deviation. Different superscripted letters indicate significant differences among samples  $P < 0.05$ .

In the honey samples studied, the colour ranged from dark amber for Ududumbara to light amber for Welimada honey. There are significant differences in lightness (L), greenness (a) and yellowness (b) remarked between all studied types of honey (Table 3). Changes in colour might be attributed to the different floral sources of the geographical origin of the bee honey.

Table 2: Colour values of bee honey in the six geographical regions in Sri Lanka

Sample	L (lightness)	a (greenness)	b (yellowness)
Ududumbara	94.5 $\pm$ 16.8 <sup>a</sup>	16.76 $\pm$ 8.26 <sup>a</sup>	33.36 $\pm$ 3.00 <sup>a</sup>
Anuradhapura	48.4 $\pm$ 0.9 <sup>b</sup>	65.13 $\pm$ 0.57 <sup>b</sup>	122.5 $\pm$ 20.61 <sup>b</sup>
Bibila	59.0 $\pm$ 7.9 <sup>b</sup>	28.96 $\pm$ 10.68 <sup>a</sup>	46.43 $\pm$ 9.80 <sup>a</sup>
Bandarawela <sup>(a)</sup>	63.3 $\pm$ 12.9 <sup>b</sup>	26.23 $\pm$ 8.18 <sup>a</sup>	56.46 $\pm$ 17.56 <sup>a</sup>
Welimada	0.00 $\pm$ 0.00 <sup>c</sup>	81.80 $\pm$ 0.00 <sup>c</sup>	99.1 $\pm$ 0.00 <sup>b</sup>
Jaffna	61.8 $\pm$ 12.5 <sup>b</sup>	20.56 $\pm$ 12.09 <sup>a</sup>	36.1 $\pm$ 10.57 <sup>a</sup>

All values are shown as the mean of triplicates  $\pm$  Standard Deviation. Different superscripted letters indicate significant differences among samples  $P < 0.05$ .

### 3.3 Development of an Analytical Tool Based on the Bee Honey Colour

The development of the analytical tool based on the bee honey colour was comprised of the following major steps (Figure 2 and 3).

**Step 1:** The obtained L - lightness, a – greenness and b – yellowness values were converted to their original colours using a standardised custom-built colour converter software DATACOLOR Tool Plus (Figure 2). These individual colours of bee honey were then printed on transparent circular cards (3.5 cm diameter) (Figure 3a).

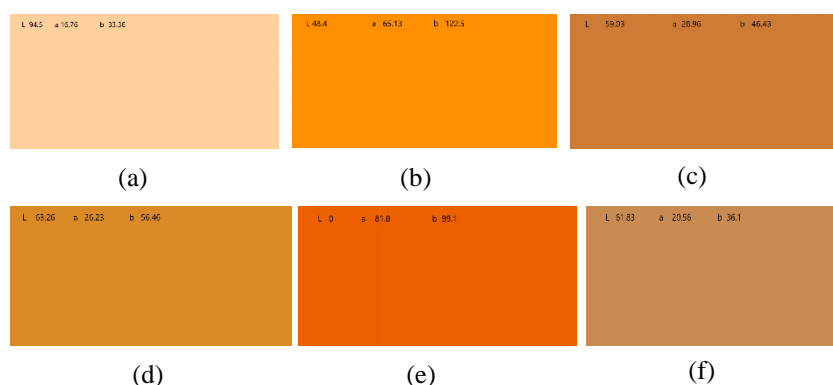

Figure 2: Converted standard colours from the obtained lightness (L), greenness (a) and yellowness (b). (a) Ududumbara, (b) Anuradhapura, (c) Bibila, (d) Bandarawela, (e) Welimada, (f) Jaffna bee honey samples

**Step 2:** Then the colour card guide was developed based on the geographical locations and the season of honey collection (Figure 3e). This chart was developed based on the major and minor honey collecting districts in Sri Lanka. The developed colour cards in step 1 are considered as the standard

colour of the respective region within the given time (April season). However due to the time limitation of the research and the prevailed COVID-19 pandemic situation, it was not possible to completely collect and generate all the standard colours for every geographical location and respective time periods. Consequently, this study initiated the preliminary research work of developing the colour analysis tool for local beekeepers with the intension of further improvements which is also highlighted in this section.

**Step 3:** A simple bee honey colour analysis toolbox was developed as a part of this study (Figure 3f). This is comprised of an unknown sample chamber and a standard sample chamber. Printed standard colour cards in the step 1 can be loaded into the standard colour card chamber (Figure 3c) and the unknown bee honey sample can be placed in the unknown sample chamber (Figure 3d). Then both chambers are fixed to the bottom of body tubes (Figure 3b). Then the body tubes can be placed on the light sources. Colour comparison is done by observing through the body tube with naked eye. Thus, with the help of the light source, evaluator can clearly identify whether the unknown sample has a similar colour to the standard bee honey colour card.

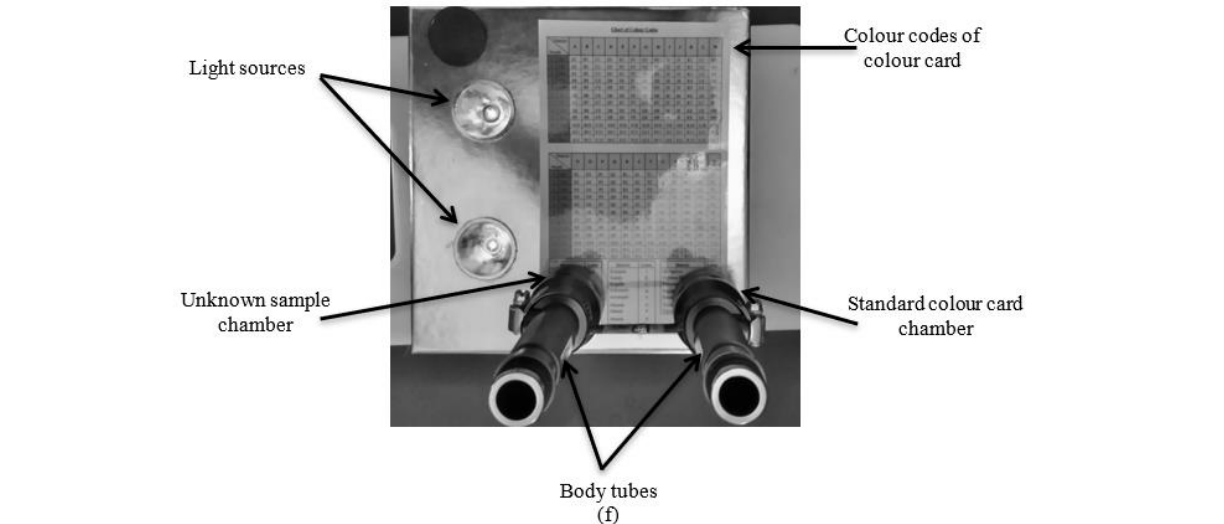
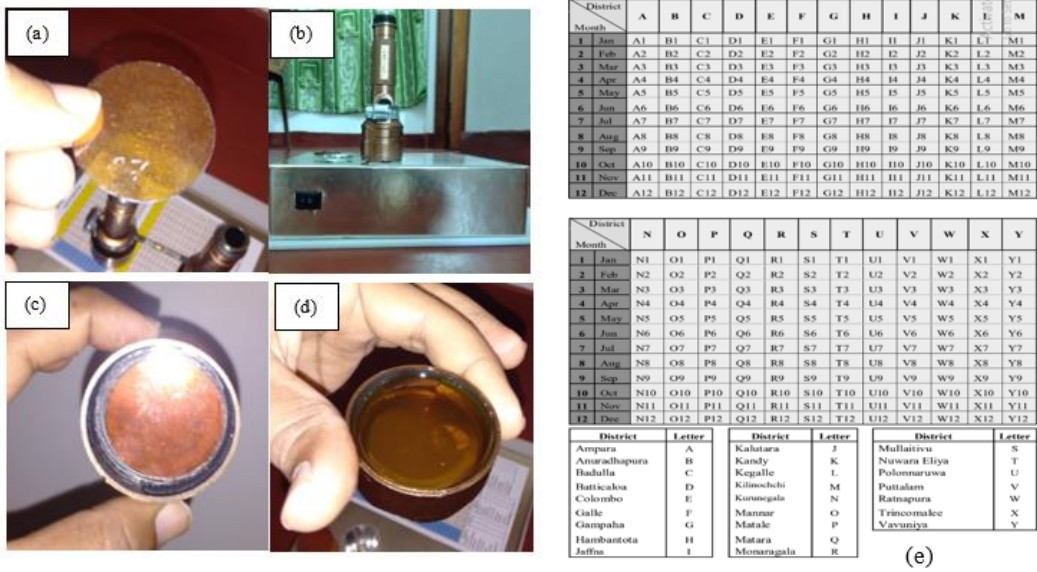

Figure 3: (a) Standard printed colour card, (b) Side view of colour analysis toolkit, (c) Colour card chamber with colour card, (d) Sample chamber with honey, (e) Code chart of colour cards based on the season and the geographical location, (f) The developed bee honey colour analysing toolkit.

The colour analysis toolkit developed in this study is simple, inexpensive, portable, versatile compared to the laboratory level colour analysis instruments and requires limited technical skills of handling. It can be used to identify the floral origin, geographical location, harvesting season, any type of inferior quality, or adulterations of bee honey. However, this colour analysis toolkit needs further improvements. To provide a comprehensive analysis of bee honey colour in Sri Lanka, this colour analysis toolkit needs to consider the relationship of the colour of bee honey to its floral origin and moisture content.

#### 4. CONCLUSIONS

This study describes the physicochemical characteristics of bee honey samples collected during the April season from Udubumbara, Anuradhapura, Bibila, Bandarawela, Welimada and Jaffna regions of Sri Lanka. All the physicochemical parameters of the analysed honey samples except the moisture content of the Bandarawela sample, are within the recommended range according to the Codex Alimentarius and SLSI standards. Physicochemical parameters and microscopic properties of bee honey are significantly influenced by the geographic region. There is a significant difference in the colour observed across all the honey samples that were studied. Changes in colour might be attributed to the floral origin of the geographical origin. Based on the colour values, a simple and a versatile bee honey colour analysis toolkit is proposed as a quality assessment tool for Sri Lankan bee honey which will be beneficial in increasing the commercial value.

#### ACKNOWLEDGEMENT

The authors are grateful to Mrs. A.M.U.R.K. Attanayake, Mrs. A.P. Wijekoon and Mr. K.A.K.L. Chandrasiri from the Faculty of Agriculture, University of Peradeniya for their technical support. Mr. V.G.T.M. Wijesinghe from Ceylon Bee Honey (Pvt) Ltd. and Mr. Karai Niroshan from the Jaffna Beekeeping Union are acknowledged for providing bee honey samples for the research.

#### REFERENCES

- Belay, A., Solomon, W.K., Bultossa, G., Adgaba, N. and Melaku, S., 2015. Botanical origin, colour, granulation, and sensory properties of the Haremma forest honey, Bale, Ethiopia. *Food chemistry*, 167, pp.213-219.
- Boussaid, A., Chouaibi, M., Rezig, L., Hellal, R., Donsi, F., Ferrari, G. and Hamdi, S., 2018. Physicochemical and bioactive properties of six honey samples from various floral origins from Tunisia. *Arabian Journal of Chemistry*, 11(2), pp.265-274.
- Calderone, N.W. (2012) Insect pollinated crops, insect pollinators and US agriculture: trend analysis of aggregate data for the period 1992–2009.
- Christenhusz, M. and Byng, J., (2016). The number of known plants species in the world and its annual increase. *Phytotaxa*, [online] 261(3), p.201. Available at: (<https://www.biotaxa.org/Phytotaxa/article/view/phytotaxa.261.3.1>) [Accessed 26 May 2021].
- Codex Standard for Honey CXS 12-19811 Adopted in 1981. Revised in 1987, 2001. Amended in (2019).
- Ediriweera, E.R.H.S.S. and Premarathna, N.Y.S., 2012. Medicinal and cosmetic uses of Bee's Honey—A review. *Ayu*, 33(2), p.178.
- El-Sohaimy, S.A., Masry, S.H.D. and Shehata, M.G., 2015. Physicochemical characteristics of honey from different origins. *Annals of Agricultural Sciences*, 60(2), pp.279-287.
- Fakhlai, R., Selamat, J., Khatib, A., Razis, A.F.A., Sukor, R., Ahmad, S. and Babadi, A.A., 2020. The toxic impact of honey adulteration: A review. *Foods*, 9(11), p.1538.
- Jayasinghe, C., Ranganma, L., Jayakala, B., Karunasekara, D., Nandasiri, R., Jayasekara, C., Pakyanathan, H. and Senarath, S., 2012. Characterization and authentication of Sri Lankan bee honey. In *Proceedings of the International conference on Chemical Science* (pp. 87-92).
- Lewkowski, O., Mureşan, C.I., Dobritzsch, D., Fuszard, M. and Erler, S., 2019. The effect of diet on the composition and stability of proteins secreted by honeybees in honey. *Insects*, 10(9), p.282.

- Peters, R. S., Krogmann, L., Mayer, C., Donath, A., Gunkel, S., Meusemann, K., & Niehuis, O. (2017). Evolutionary history of the Hymenoptera. *Current Biology*, 27(7), 1013-1018.
- Punchihewa, R.W.K., 1994. Beekeeping for honey production in Sri Lanka: management of Asiatic hive honeybee *Apis cerana* in its natural tropical monsoonal environment. *Sri Lanka Department of Agriculture and Canadian International Development Agency*.
- Saranraj, P. and Sivasakthi, S., 2018. Comprehensive Review on Honey: Biochemical and Medicinal Properties. *J. Acad. Ind. Res*, 6(10), p.165.
- Silva, H.G.Y.R., Seneviratne, R.A.C.H., Gunawardana, M. and Jayasinghe, C.V.L., 2018. Pollen Analysis of Natural Bee Honeys from Different Regions of Sri Lanka. *Journal of Food and Agriculture*, 11(1), pp.23-36.
- Sri Lanka Standard Institute, Sri Lankan Standards 464:1979: Bee's Honey (1979).
- Szabó, R.T., Mézes, M., Szalai, T., Zajác, E. and Kovács-Weber, M., 2016. Colour identification of honey and methodical development of its instrumental measuring. *Columella: Journal of Agricultural and Environmental Sciences*, 3(1), pp.29-36.
- Tapia, M.S., Alzamora, S.M. and Chirife, J., 2020. Effects of water activity (aw) on microbial stability as a hurdle in food preservation. *Water activity in foods: Fundamentals and applications*, pp.323-355.
- Zamora, M.C., Chirife, J. and Roldán, D., 2006. On the nature of the relationship between water activity and% moisture in honey. *Food Control*, 17(8), pp.642-647.

# Development of Ash-Plantain Based Sauce with Incorporation of Oyster Mushrooms Powder

S.L.T. Kumarasingha\*<sup>3</sup>, U.A.S.K. Edirisinghe<sup>1</sup>, M.A.J. Wansapala<sup>2</sup>, G.W.A.S. Lakmini<sup>3</sup>

<sup>1</sup>Department of Agriculture & Food Technology, University of Vocational Technology, Sri Lanka,

<sup>2</sup>Department of Food Science & Technology, University of Sri Jayawardenepura, Sri Lanka

<sup>3</sup>Department of Agricultural Technology, University of Colombo, Sri Lanka

## ABSTRACT

*Ash-plantain (Musa paradisiacea) is the fourth major food crop and a major source of energy used for non-communicable diseases. Therefore the study was focused on introducing an Ash-plantain based sauce as a supplementary food and ash plantain puree with functional ingredients. The best formula was selected by sensory analysis with the help of thirty (30) semi-trained panelists using three formulae. Proximate properties (i.e. moisture%, protein%, fat%, and ash%) and pH Brix values were analyzed. Microbiological safety of the final product was determined within one-week interval of 30 days of storage period. The results of the analysis revealed that higher sum ranks scored for all the sensory attributes and overall acceptability in formula 3 which contained 30.3% ash-plantain, 37% boiled water, 8.4 % of tamarind puree, 3.8% of dried mushroom powder, 3.4% of chili powder, 16% of other condiments, 0.3% of vinegar, 0.8% of salt and 0.2% of stevia powder. pH and Brix values of the final product were recorded as 4.35 and 31<sup>0</sup> respectively. The percentage of moisture, protein, ash, and fat were recorded as 27.25, 1.95, 1.8, 1.44 respectively. For the selected sample within one month, the total coliform test was negative. Yeast and Mold recorded a range of 25-50 CFU/g, total colony counts were recorded between 25-250 CFU/g.*

**Keywords:** Ash-plantain, Ash-plantain based sauce, Mushroom powder, Supplementary food.

## 1. INTRODUCTION

Ash-plantain or mature unripe banana (*Musa paradisiacea*) is main food crop in Africa and a major source of energy for millions of people (Adepoju *et al.*, 2012). Also in Sri Lanka it is the largest herb having valuable medicinal Properties (Ediriweera, 2008). It is perennial crops that cultivate well in a huge range of environments. They belong to the family of *Musaceae* with the genus *Musa* and extraordinary have been crops of significance to human societies (Ploetz *et al.*, 2007). It has been cultivated for more than 4000 years (Alabi *et al.*, 2013) and different varieties are the main food in the tropical regions of the world (Salazar *et al.*, 2017). Also presently, after rice, wheat, and maize, ash-plantain rank as the fourth most important food crop in the world (Adepoju *et al.*, 2012). Beneficial features of ash-plantain promote good digestion, improves affective states, helps to the retention and serves as a good source of calcium, potassium, phosphorus, and nitrogen to build and regenerate tissues in the body as well as a rich source of vitamin C and vitamin E (Kumar *et al.*, 2012). *Musa paradisiacea* is also high in dietary fiber, basically hemicellulose which is higher than in most vegetables and fruit. Apart from that plantain consumption by men could improve some reproductive functions as well as alleviate certain reproductive dysfunctions (Marengo, 2019). Also, the researchers have confirmed that it should be consumed in moderate quantities to derive its beneficial effects of enhancing male reproductive functions (Alabi *et al.*, 2013). As well as the mature green fruit of plantain makes no negative effects for men which when the plantains are cooked with spices such as onion, garlic, and ginger. It is a very successful treatment for erectile dysfunction, low sperm count, kidney failure, diabetes, and high blood pressure. Apart from that it is also very effective in thickening and increasing sperm count (Ezeji, 2013).

---

\* Corresponding Author: E mail - [lihini97k@gmail.com](mailto:lihini97k@gmail.com)

Hence sauces better allow enriching the human diet with functional useful ingredients (Kublinskaya, 2018). This study was focused to develop Ash-plantain based sauce. Ash plantain puree, dehydrated oyster mushroom powder, stevia sweetener, spices, and condiments were used as raw materials for this product.

The mushrooms have useful nutrients and high sensory characteristics (Bhuiyan & Rana, 2012). It is good to both prevent and treat hepatitis, reduces the blood cholesterol, stomach ulcers, helps to reduce blood pressure during both hyper and hypotension, has an antitumor effect and boosts the body's immune resistance, act as anti-cancer agent and prevent cardiovascular diseases (Dril *et al.*, 2019).

Apart from that stevia sweetener is added into this sauce as a sweetening agent instead of sugar as a low sugar sauce product. Stevia can be helpful to diabetic patients in decreasing caloric intake, used for centuries as a bio-sweetener, and to lower blood sugar (Goyal *et al.*, 2010). Spices and condiments such as chili powder, pepper, garlic, ginger, onion, cardamom, cinnamon, clove, and tamarind were added to incorporate the rich flavor, odor, appearance, and certain bioactive compounds. Acceptable color and taste were incorporated by using Tamarind. Hence the developed product was free from artificial food additives, the product quality with High-Density Poly Ethylene (HDPE) bottles having one month storage period of which 27.25% moisture content while presenting as a 100% natural food product. Therefore, this product development is an excellent source of supplementary diet for fighting non-communicable diseases while maintain the good quality and nutritional value.

## **2. OBJECTIVES OF THE STUDY**

### **2.1. General Objective:**

To introduce the Ash-plantain based sauce as a supplementary food

### **2.2. Specific Objectives:**

- To select the best formula for Ash-plantain based sauce
- To determine the proximate analysis of selected formula
- To determine the pH and brix values of selected formula
- To determine the shelf life of selected formula of Ash-plantain based sauce

## **3. MATERIALS AND METHODS**

The study was conducted in the laboratory of the Department of Agriculture and Food Technology at the University of Vocational Technology, Ratmalana, Sri Lanka. In the present study, all chemicals were in standard analytical grades.

### **3.1. Sample Collection**

Matured, unripe ash-plantain fruits and other minor ingredients were purchased from local market.

### **3.2. Sample Preparation**

#### **3.2.1. Preparation of the Ash-Plantain Puree**

Plantain fruits were peeled and sliced into slices, those were steamed for 40 minutes and blended with warm water to prepare the ash plantain puree based on the protocol of (Thakur *et al.*, 2014) with some modifications.

### 3.2.2. Preparation of Mushroom Powder

Oyster mushrooms were thoroughly cleaned with hot water and cut into tiny pieces, dehydrated at 71.11°C for 14 hours and powdered using a laboratory scale grinder, and packed in polythene until further use (Dril *et al.*, 2019).

### 3.2.3. Preparation of Tamarind Pulp

Tamarind (10 g) was mixed in 100 ml of hot water. The pulp was prepared by removing seeds and other unwanted parts.

### 3.2.4. Preparation of Spicy Cloth Bag

The spices (i.e. Onion, garlic, ginger, pepper, cardamom, cinnamon, and clove) were ground and transferred to the muslin cloth bag according to the confirmation of (Thakur *et al.*, 2014).

## 3.3. Formulation of Ash-Plantain Based Sauce

Considering the availability of nutritive value, flavor, and the thickness of the final processed sauce, ingredients were selected for the development as follows.

Table 1: Formulation of Ash-plantain based Sauce

Type of Ingredients (%)	F 1	F 2	F 3
Steamed ash plantain pieces	40	31.1	30.3
Boiled water	40	36.1	37
Tamarind puree	8.4	8.4	8.4
Dried mushroom powder	3.8	3.8	3.8
Chili powder	3.4	3.4	3.4
Other condiments	16	16	16
Stevia powder	0.2	0.2	0.2
Vinegar	0.3	0.3	0.3
Salt	0.8	0.8	0.8

Selective ingredients in specific amounts were used as recommended by (Thakur *et al.*, 2014) with some modifications which first both prepared ash plantain puree and the tamarind pulp were placed in a stainless steel vessel and mixed thoroughly based on the above mentioned formula. After 2-3 minutes heating dehydrated mushroom powder, chili powder, stevia powder, and salt were added one by one into the mixture and stirred thoroughly. After that prepared spicy cloth bag was kept in the mixture and concentrated by continuous heating. Step by step Brix value was checked and the vinegar was added at the endpoint. When the Brix value of the mixture was reached 31<sup>o</sup>, the mixture was removed from the heat, and pH was measured. The product was filled into sterilized High-Density Poly Ethylene (HDPE) bottles, cooled up to room temperature, and stored under refrigerated condition (4±1 °C) for sensory analysis, proximate properties, pH value, Brix value and microbiological analysis. The production process is described in Figure 1.

## 3.4. Selection of Best Formulae for the Ash-Plantain Based Sauce

The sensory evaluation was conducted to select the best formulae with thirty semi trained panelists (i.e. including both males and females). The responses of the panelists regarding the color, appearance, odor, texture, taste, after taste as well as overall acceptability of the samples were collected with five point hedonic scale and the final results statistically treated for analysis of variance for factorial designs (ANOVA) using Minitab software with the confirmations described by (Dril *et al.*, 2019).



### 3.5. Determination of the Proximate Composition of Selected Formulae

percentage of moisture, fat, protein, and ash content of the selected formulae of processed sauce were determined as per the standard methods described in the (AOAC, 2005) guidelines (i.e. Moisture content of the samples was analyzed using the oven drying method at 105°C. The Kjeldahl method was used to determine the crude protein of the samples. Crude fat was determined from dried sample with Soxhlet extraction. Total ash content was determined of in a muffle furnace of samples at 550°C for 5 hours.)

### 3.6. Determination of the Ph Value and Brix Value of Selected Formulae

The brix value (i.e. total soluble solid content) of the sample was determined using the hand refractometer with a range of 0-50<sup>0</sup> and the sample pH value was determined by the digital pH meter.

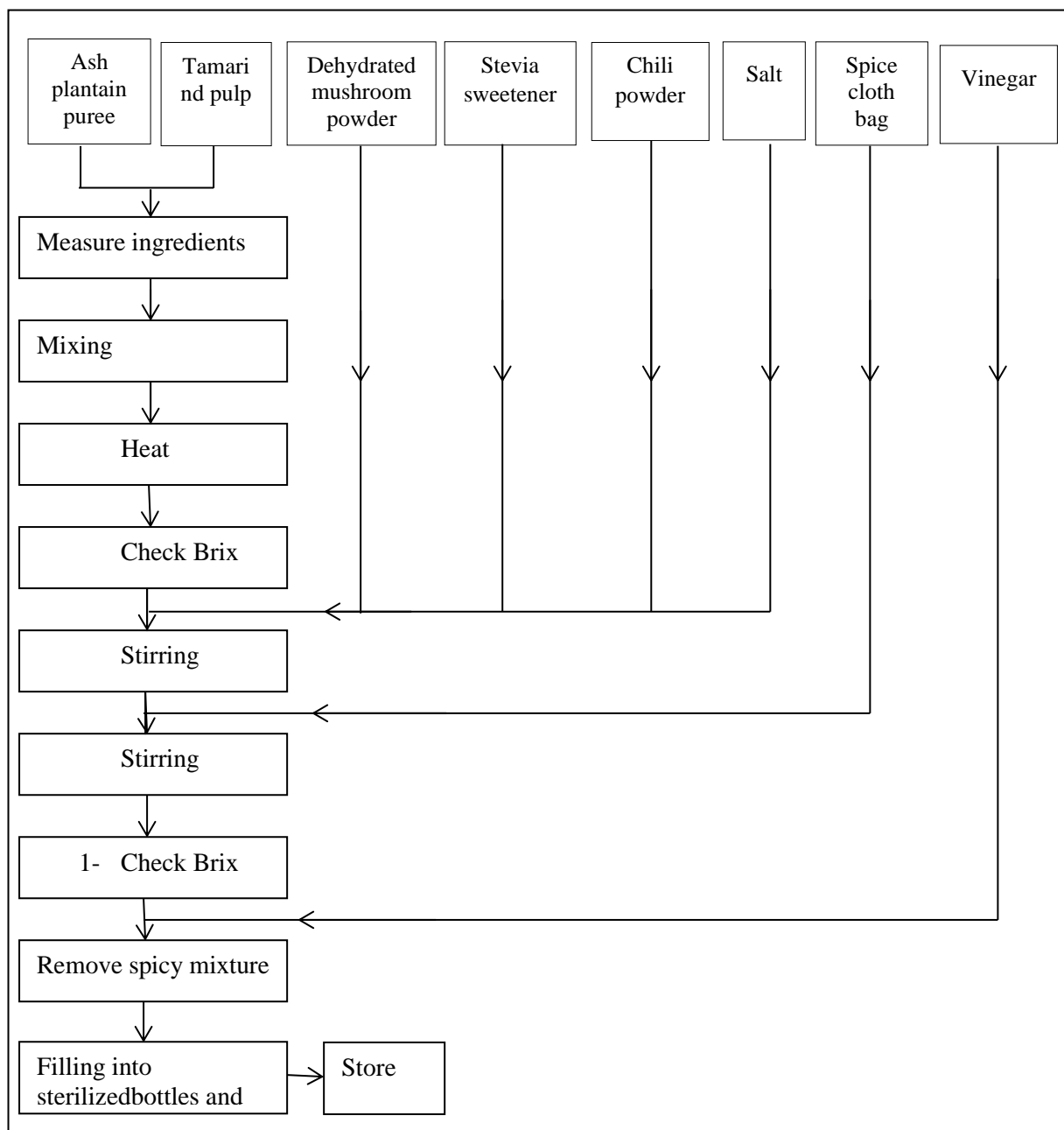

Figure 1: Flow Diagram for Preparation Steps of Ash-Plantain based Sauce

### 3.7. Determination of the Microbial Safety of Selected Formulae

The AOAC guidelines for bacterial analysis were used for this analysis. Samples were tested within one-week interval of 30 days of the storage period in refrigerated condition. The total coliform count was enumerated on sterile Mac Conkey agar, followed by incubation at 37 °C for a maximum of 48 h. Yeast and molds count was determined on sterile PDA medium followed by incubation at 25 °C for 62 h. The total colony count (TCC) was determined using maximum recovery diluent at 37 °C for 48 h. The number of colonies was recorded with a help of colony counter and, the results were reported as the amount of colony forming unit (CFU/g) of processed sample (Kassa & Azene, 2017).

## 4. RESULTS AND DISCUSSION \

### 4.1. Selection of Best Formulae for the Ash-Plantain Based Sauce

The results showed the highest rank for the appearance was obtained by formulae 3 (i.e. 79.5) with a p value =0 (Figure 2). According to the results of the Friedman test, the formulae 3 was obtained the highest rank (i.e.63.5) for odor with a significant difference 1.13 (P=0.569).

S = 31.62 DF = 2 P = 0.000				
S = 42.16 DF = 2 P = 0.000 (adjusted for ties)				
				Sum of
Treatment	N	Est Median		Ranks
1	30	3.1667		36.5
2	30	4.0000		64.0
3	30	4.3333		79.5
Grand median = 3.8333				

Figure 2: Appearance Acceptability versus Treatment blocked by Analyst

S = 0.95 DF = 2 P = 0.622				
S = 1.13 DF = 2 P = 0.569 (adjusted for ties)				
				Sum of
Treatment	N	Est Median		Ranks
1	30	3.3333		56.0
2	30	3.5000		60.5
3	30	3.6667		63.5
Grand median = 3.5000				

Figure 3: Odor Acceptability versus Treatment blocked by Analyst

According to the results of the Friedman test the formulae 3 was obtained the highest rank (i.e.69.5) for texture with a p value of 0.013 and for flavor formula 3 scored 71.0 with the p value of 0.017 (Figure 4 and 5).

S = 5.02 DF = 2 P = 0.081				
S = 8.72 DF = 2 P = 0.013 (adjusted for ties)				
				Sum of
Treatment	N	Est Median		Ranks
1	30	3.8333		52.5
2	30	4.0000		58.0
3	30	4.1667		69.5
Grand median = 4.0000				

Figure 4: Texture Acceptability versus Treatment blocked by Analyst

S = 6.20 DF = 2 P = 0.045				
S = 8.18 DF = 2 P = 0.017 (adjusted for ties)				
				Sum of
Treatment	N	Est Median		Ranks
1	30	3.2500		56.0
2	30	3.0833		53.0
3	30	3.9167		71.0
Grand median = 3.4167				

Figure 5: Flavor Acceptability versus blocked Treatment by Analyst

The results showed the highest rank for the color was obtained by formulae 3 (i.e. 71.0) with a p value = 0.002 (Figure 6). According to the results of the Friedman test the formulae 3 was obtained highest rank (i.e.72.5) for overall acceptability with a p value of 0 (Figure 7).

S = 9.32 DF = 2 P = 0.009			
S = 12.85 DF = 2 P = 0.002 (adjusted for ties)			
			Sum of
Treatment	N	Est Median	Ranks
1	30	3.0000	47.5
2	30	4.0000	61.5
3	30	4.0000	71.0
Grand median = 3.6667			

Figure 6: Color Acceptability versus Treatment blocked by Analyst

S = 14.82 DF = 2 P = 0.001			
S = 19.54 DF = 2 P = 0.000 (adjusted for ties)			
			Sum of
Treatment	N	Est Median	Ranks
1	30	3.0000	43.5
2	30	4.0000	64.0
3	30	4.0000	72.5
Grand median = 3.6667			

Figure 7: Overall Acceptability versus Treatment blocked by Analyst

Therefore it is confirmed that the formulae 3 which contained 30.3% ash-plantain, 37% water, 8.4 % of tamarind puree, 3.8% of dried mushroom powder, 3.4% of chili powder, 16% of other condiments, 0.3% of vinegar, 0.8% of salt and 0.2% of stevia powder was obtained highest ranks concerning appearance, odor, texture, flavor, color and overall acceptability.

#### 4.2. Determination of the Proximate Composition of Selected Formulae

The results of the proximate analysis regarding the percentage of moisture, fat, protein, as well as ash values were showed in Table 3 and those were in agreement with the guidelines of (AOAC, 2005).

Table 3: Proximate Composition of the Sauce

Nutrient	Results
Moisture	27.25 %
Fat	1.44 %
Protein	1.95 %
Ash	1.8 %

#### 4.3. Ph Value and Brix Value of the Selected Formulae

The pH value of the final processed sample was recorded as 4.35 and the Brix value (i.e. TSS) was recorded as 31<sup>0</sup>. Therefore it was concluded that the pH value and the Brix value of this investigation results were more similar to the explanations confirmed by (Yarosan, et al., 2018) and (Thakur *et al.*, 2014).

#### 4.4. Microbial Count of the Selected Formulae

The total coliform test was negative for the selected sample within one month and Yeast and Mold were recorded with a range of 25-50 CFU/g. But that value of the total colony counts was gradually increased with time and it was closed to 250 CFU/g after one month. Therefore based on the Microbiological evaluation results the selected formulae are safe for consumption within one month (Maturin & Peeler, 2001) under refrigerated conditions.

### 5. CONCLUSIONS

The formulae 3 was selected as the best formulae which contained 30.3% ash-plantain and 37% boiled water, 8.4 % of tamarind puree, 3.8% of dried mushroom powder, 3.4% of chili powder, 16% of other condiments, 0.3% of vinegar, 0.8% of salt and 0.2% of stevia powder was obtained highest ranks with respect to appearance, odor, texture, flavor, color and overall acceptability. The moisture, protein, crude fat, and ash contents of the final product were 27.25%, 1.44%, 1.95%, and 1.8% respectively. The pH and the Total Soluble solids (TSS) content of the final products were 4.35 and 31<sup>0</sup> respectively. The microbial safety of the product was one month period under refrigerated conditions. This product

can be suggested to carry out as a supplementary food ingredient for non-communicable diseases for further studies.

## REFERENCES

- Adepoju *et al.*, 2012. Nutrient composition and contribution of plantain (*Musa paradisiacea*) products to dietary diversity of Nigerian consumers. *Biotechnology*, 11(71), pp.13601-05.
- Alabi, A.S., Omotoso, G.O. & Tagoe, C.B., 2013. Beneficial effects of low dose *Musa paradisiaca* on the semen quality of male Wistar rats. *Nigerian Medical*, pp.92-95.
- AOAC, M., 2005. *Official Method of Analysis 12th edition. Association of Official Agricultural Chemists, Washington, D.C.USA.*
- Bhuiyan, M.H.R. & Rana, M.S., 2012. KETCHUP DEVELOPMENT FROM FRESH MUSHROOM. *Bangladesh research publications*, 7, pp.182-88.
- Dril, A.A., Rozhdestvenskaya, L.N. & Sapozhnikov, A.N., 2019. Development of sauce production technology based on cultivated oyster mushrooms *Pleurotus ostreotus* (jacq.) P. Kumm). *Agricultural and Biological Science*.
- Ediriweera, E.R.H.S.S., 2008. Medicinal uses of Bananas and Plantains in Sri Lanka. pp.79-90.
- Ezeji, E., 2013. *UNRIPE PLANTAIN AND MALE POTENCY AND FERTILITY*. [Online] Available at: <https://www.africaresource.com/rastal/sesostris-the-great-rth.t-hercules/unripe-plantain-and-male-potency-and-fertility/>.
- Goyal, S.K., Samsher & Goyal, R.K., 2010. Stevia (*Stevia rebaudiana*) a bio-sweetener: a review. *Food Science and Nutrition*, 61(1), pp.1-10.
- Kassa, A.G. & Azene, M.K., 2017. Microbiological quality and safety of street vended meat sauce in Bahir Dar Town.
- Kublinskaya, I., 2018. DEVELOPMENT OF THE TECHNOLOGY OF MUSHROOM SAUCE WITH FUNCTIONAL INGREDIENTS. p.4/3(42).
- Kumar, K.P.S., Bhowmik, D., Duraiavel, S. & Umadevi, M., 2012. Thaditional and Medicinal Uses of Banana. *Ppharmacognosy and Phytochemistry*, 1(3), pp.57-70.
- Marengo, E., Mazzucco, E., Robotti, E., Gosetti, F., Manfredi M., Calabrese, G., 2016. Characterization Study of Tomato Sauce Stored in Different Packaging Materials.
- Marengo, K., 2019. *Plantains: Nutrition Facts and Health Benefits*. [Online] Available at: <https://www.healthline.com/health/food-nutrition/plantain-nutrition-benefits#digestion>.
- Maturin, L. & Peeler, J.T., 2001. BAM Chapter 3: Aerobic Pplate Count.
- Ploetz, R.C., Kepler, A.K., Daniells, J. & Nelson, S.C., 2007. Banana and plantain-an overview with emphasis on Pacific island cultivars. *Species Profile for Ppacific Island Agroforestry*.
- Salazar, A.C. *et al.*, 2017. Isolation and partial characterization of starch from banana cultivars grown in Colombia. *Biological Macromolecules*, pp.240-46.
- Thakur, N., Thakur, M., Thakur, G. & Lal, S., 2014. Increased Shelf Life and Safety of Ketchup Prepared from Organically Raised Tomato (CV. Solan Lalima).
- Yarason, A.Y. *et al.*, 2018. COMPARATIVE ANALYSIS OF TWO DIFFERENT PROCESSING METHODS OF TOMATO (*Lycopersicum Solanum*) PASTE IN FEDERAL COLLEGE OF FORESTRY, JOS, PLATEAU STATE, NIGERIA. *Advanced Academic Research*, 4(7).

# Development of Jackfruit Flesh Flour Incorporated Healthy Composite Flour Mixture with Selected Grains and Pulses

M.L.P. Thathsarani<sup>\*4</sup>, M. A. J. Wansapala<sup>2</sup>, U.A.S.K. Edirisinghe<sup>1</sup>, G.W.A.S. Lakmini<sup>3</sup>

<sup>1</sup>Department of Agriculture and Food Technology, University of Vocational Technology, Sri Lanka

<sup>2</sup>Department of Food Science and Technology, University of Sri Jayewardenepura, Sri Lanka

<sup>3</sup>Department of Agricultural Technology, Faculty of Technology, University of Colombo, Sri Lanka

## ABSTRACT

*Highly purified wheat flour-based food is a major reason for Non communicable diseases (NCDs). This study focused on formulating a composite flour mixture using jackfruit flesh flour (JF), atta flour (AF), corn flour (CF), soy flour (SF) and rice flour (RF). Three formulations were used (i.e. F1, F2, F3) and the paired comparison test was applied with sensory panel consisting of thirty semi-trained panelists to select the most preferred sample with the highest consumer acceptance. The proximate analysis was carried out for the selected formula (i.e., Moisture%, protein%, fat%, ash%, dietary fiber%) using AOAC methods and the microbiological safety of the formulae. All the parametric and non-parametric data were analyzed using MINITAB-19 version at 0.01 significant levels. Based on the sensory evaluation, the formula 2 was selected as the best composite flour mixture. The results of the proximate analysis regarding the formulate revealed that 100 g of the composite flour mixture contains 13.72 g of protein, 4.31 g of fat, 2.01 g of ash and 12.5 g of dietary fiber. According to the findings of the study this composite flour mixture can be used as a substitute for wheat flour for products such as pittu, rotti, cakes, muffins, aggala and string hoppers.*

**Keywords:** Composite flour mixture, Jackfruit flesh flour, NCDs.

## 1. INTRODUCTION

Due to the high sensory properties and busy lifestyles people prefer to consume refined wheat flour-based bread and flat bread products frequently. One of the major health risks associated with refined wheat flour is non communicable diseases (NCD) (i.e. diabetics, hypercholesterolemia, hypertension, and obesity) (WHO, 2014). Wheat flour can release a high load of glucose to the body due to its high glycemic index. Thereby rapid rise of the blood glucose level can be observed within a short period after consumption. This may create type two diabetics (Wang , *et al.*, 2021). Therefore, new composite flour formulae which consists of resistant starch, fiber, proteins, and other essential micronutrients as a replacement for refined wheat flour is a timely need to minimize this risk. To achieve the objectives, five different of raw materials were used for formulation (i.e. Jackfruit flesh flour, Atta flour, corn flour, soy flour and rice flour). Jackfruit is known to be the largest edible fruit in the world, and it is rich in nutrients including carbohydrates, protein, fat, dietary fiber, vitamins, minerals, and phytochemicals. Although, one of the previous research studies in Bangladesh stated that the post-harvest loss of jackfruit is 38% of total production (HOSSAIN, *et al.*, 2017). According to the previous literature, 100g of Jackfruit flesh flour contains 81.64g carbohydrates, 11.02g of protein, and 2.36g of dietary fiber and 1.01g of fat. Jackfruit flesh flour incorporates resistant starch as a major component and other minor nutrients to the composite flour mixture (Goswami & Chacrabati, 2016)(Ranasinghe, *et al.*, 2019). Hence the unrefined ground product Atta flour contains high fiber content. Therefore, Atta is healthier than refined wheat flour (Pande, *et al.*, 2017). Corn flour contains high levels of important minerals as calcium, iron, and potassium and Vitamin A (Rosado, *et al.*, 2005). Incorporation of soy flour into flour mixtures may be useful for the incorporation of high-quality vegetable proteins with majority of essential amino acids and other micronutrients (Rosado, *et al.*, 2017). Rice flour was also used as a source of carbohydrate and proteins.

---

\*Corresponding Author: Email- [pawarnalokugee@gmail.com](mailto:pawarnalokugee@gmail.com)

## **2. OBJECTIVES OF THE STUDY**

### **2.1. Major Objective of the Study**

To develop a healthy composite flour mixture as a substitute for wheat flour for bread and flat bread products.

### **2.2. Specific Objectives**

1. To select and prepare the high-quality raw materials
2. To determine the best formulae for the composite flour mixture
3. To analyze the proximate nutrient composition of the selected formulae
4. To analyze the microbiological safety and the shelf life of the selected formula.

## **3. MATERIAL AND METHODS**

This study was conducted in the Food processing laboratory at Department of Agriculture and Food Technology of University of Vocational Technology, Ratmalana, Sri Lanka.

### **3.1. Sample Collection**

Raw unripe Jackfruit, Atta flour, Soybean seeds, Corn seeds and rice (Rathu Kakulu) were purchased from the local market

### **3.2. Preparation of Raw Materials**

#### **a. Preparation of Jackfruit Flesh Flour (JF)**

Raw Jackfruit flesh was removed, washed, and cut into small pieces, dehydrated at 60°C, powdered and then sieved by using a 200µm sieve.

#### **b. Preparation of Corn Flour (CF)**

Corn seeds were washed, sundried, powdered, sieved by using a 200µm sieve and heated up to 60°C for 10 minutes.

#### **c. Preparation of Soy Flour (SF)**

Soy seeds were washed, sundried, powdered, sieved by using a 200µm sieve and heated up to 60°C for 10 minutes.

#### **d. Preparation of Rice Flour (RF)**

Rice was washed, sundried, powdered, sieved by using a 200µm sieve and then heated up to 60°C for 10 minutes.

#### **e. Preparation of Composite Flour Mixture**

The three flour formulations based on JF, CF, SF, RF, AF were prepared according to the scientific method as described by table 1. (Kadam, *et al.*, 2013)

After the raw material preparation, the JF, CF, SF, RF, AF were measured according to the formulae shown in Table 1 and properly mixed, then stored in triple laminated packaging bags under the room temperature condition (60 °C).

Table 1: Formulation of the composite flour mixture

Substitution of JF by AF, CF, SF and RF			
Ingredients, g	F1-50%	F2-40%	F3- 30%
Jackfruit Flour	250	200	200
Atta Flour	150	200	175
Corn Flour	50	50	75
Soy Flour	35	35	35
Rice Flour	15	15	15

### 3.3. Preparation of Products by Composite Flour

*Aggala* were prepared by traditional method using composite flour mixture with mixing sugar and scraped coconut and salt. Also, *pittu* and *roti* were prepared on following the traditional methods. Before preparing string hoppers composite flour mixture was pre-cooked for 15-20 minutes by using streamer and followed the traditional method. Cakes and muffins were prepared by following usual recipes and baked at 180 °C for 30 - 40 minutes.

### 3.4. Sensory Analysis

Sensory evaluation was conducted for three roti samples (i.e.P001, P002, P003) prepared by three different composite formulae with 30 semi trained panelists as described by Amerine et al on 5-point hedonic scale (Pangborn, *et al.*, 1965). Each category was rated 1 (strongly dislike) to 5 (strongly like) in order to evaluate the statistically significant of the panel test. The scores were tabulated and analyzed by non-parametric Friedman test.

### 3.5. Proximate Analysis of the Composite Flour

To determine the proximate composition, percentage of moisture, fat, protein, total dietary fiber and ash content of the selected formulae of composite flour mixture were analyzed according to the standard methods described in the AOAC 2019 guideline. (i.e., moisture content of the samples was determined using the oven dry method at 105°C with AOAC official method 934.01. The crude fat content was determined from dried samples with AOAC official method 2003.05. Crude protein content was determined using the Kjeldahl method with AOAC official method 2003. Total ash content was determined of samples in muffle furnace at 550°C for 5 hours. Total dietary fiber content was determined by following enzymatic gravimetric method with AOAC official method 985.29.) (AOAC, 2019)

### 3.6. Shelf Life of the Composite Flour

The shelf life of the selected best composite flour mixture was evaluated for moisture content and microbial safety (i.e. Microbial load was determined by serial dilution of each sample in five-fold sterile 0.1% media by pour plate technique. Coliform count was determined using MacConkey agar with 24 hours incubation at 37°C; Potato Dextrose Agar was used for yeast/mold with 48 hours incubation at 25°C while for TCC it was 48 hours incubation at 37°C). Those parameters were determined by monthly interval with triple laminated packages under room temperature condition (60°C). (AOAC, 1990)

### 3.7. Quality Control

All glassware used in the assay were cleaned using detergent water, then rinsed with 5% nitric acid, rinsed several times with de-ionized water and finally oven dried. All plastic utensils were cleaned with detergent water and de-ionized water, respectively. Then they were allowed to dry under room temperature.

### 3.8. Data Management and Statistically Analysis

All the parametric and non-parametric data were analyzed using AOAC standards (2019, 21<sup>st</sup> edition) and MINITAB-19 version at 0.01 significant levels respectively.

## 4. RESULTS AND DISCUSSION

### 4.1. Selection of the Best Formula for Composite Flour Mixture

The results showed that highest rank for the appearance was obtained by the P002 which was prepared using second formulae (i.e.83.0) with the p value=0 (Figure 01). According to the results of the Friedman test formula 2 was obtained the highest rank (i.e. 85.0) for the color. (Figure 02)

S = 29.27	DF = 2	P = 0.000	
S = 39.02	DF = 2	P = 0.000	
	Est	Sum of	
Treatment	N	Median	Ranks
1	30	3.000	42.0

Figure 1: Appearance Acceptability versus Treatment blocked by Analyst

S = 33.27	DF = 2	P = 0.000	
S = 43.87	DF = 2	P = 0.000	
	Est	Sum of	
Treatment	N	Est Median	Ranks
1	30	3.0000	42.0

Figure 2: Color Acceptability versus Treatment blocked by Analyst

According to the results of the Friedman test, the P002 prepared from F2 scored 85.5 with the p value=0 for the odor (Figure 03), and for taste, F2 has obtained the highest rank (i.e. 85.0).

S = 38.22	DF = 2	P = 0.000	
S = 44.96	DF = 2	P = 0.000	
	Est	Sum of	
Treatment	N	Median	Ranks

Figure 3: Odor Acceptability versus Treatment blocked by Analyst

S = 38.60	DF = 2	P = 0.000	
S = 45.86	DF = 2	P = 0.000	
	Est	Sum of	
Treatment	N	Median	Ranks

Figure 4: Taste Acceptability versus Treatment blocked by Analyst

S = 45.87	DF = 2	P = 0.000	
S = 50.50	DF = 2	P = 0.000	
	Est	Sum of	
Treatment	N	Median	Ranks

Figure 5: After taste Acceptability versus Treatment blocked by Analyst

S = 42.12	DF = 2	P = 0.000	
S = 49.07	DF = 2	P = 0.000	
	Est	Sum of	
Treatment	N	Median	Ranks

Figure 6: Overall Acceptability versus Treatment blocked by Analyst



Based on the results of the Friedman test the formula 2 was obtained the highest rank (i.e.88.0) for taste attribute of the P002 with the p value=0. (Figure 05) According to the findings, it is confirmed that the formulae 2 which contained 40% of Jack fruit flesh flour, 40% of Atta flour, 10% of corn flour, 7% of soy flour and 3% of Rice flour was obtained the highest ranks for appearance, color, odor, taste, aster taste and overall acceptability.

General comments by the panelists regarding sensory attributes were also evaluated. Most of the panelists preferred the taste and the quality of product 002. Therefore, the same percentages of Jackfruit flesh flour and Atta flour may be responsible for the best sensory attributes of the prepared product from the second flour formula. Traditional foods as *aggala*, *pittu*, *roti*, string hoppers and cakes, muffin were in prepared by the best formula 2.

#### 4.2. Proximate Composition of Selected Flour Formulae

The results of the proximate analysis regarding to the percentage of moisture, fat, protein, dietary fiber, and ash values were showed in Table 2 and those were in agreement with the AOAC 2019 guideline.

Table 2: Proximate composition of the composite flour mixture

Nutrient	Results (g / 100 g)
Moisture	8.78±0.02
Fat	4.31±0.09
Protein	13.72±0.15
Minerals	2.01±0.05
Total Dietary Fiber	12.5±0.04

#### 4.3. Shelf of the Composite Flour Mixture

According to the results, coliform was not detected in the composite flour mixture throughout the storage period of 4 months maybe due to hygienically practiced storage conditions and processing steps. Good handling practices as cleaning the grinder and other equipment with hot water (65°C) may be caused the absence of coliform. The molds and yeast count were zero during first 3 months in the flour mixture, due to low moisture content. The zero level of yeast and mold count has recorded due to low water activity. Dehydration temperature of all raw materials were maintained on or above 60°C (i.e. above the danger zone of the bacterial growth). Although the value of total colony count was gradually increased with time, and it was closed to 250/g after 4 months.

#### 4.4. Changes in Moisture Content during Storage

Figure 7 indicated that the moisture content of the composite flour mixture was changed significantly during the storage period. The moisture content of composite flour varied from 8.40 to 10.10 in the triple laminated bags for the period of 4 months. The average mean values were 8.78% 0 days, 9.04% on 30 days, 9.61% on 60 days, 9.82% on 90 days, and 10.02% on 120 days. According to Olitino *et al.*, the amount of moisture content in a food product will determine its shelf life (Olitino, *et al.*, 2017). Scientific investigations have reported that the acceptable limit of moisture content in flour formulations is not more than 10% for long-term storage (OJO, *et al.*, 2017).

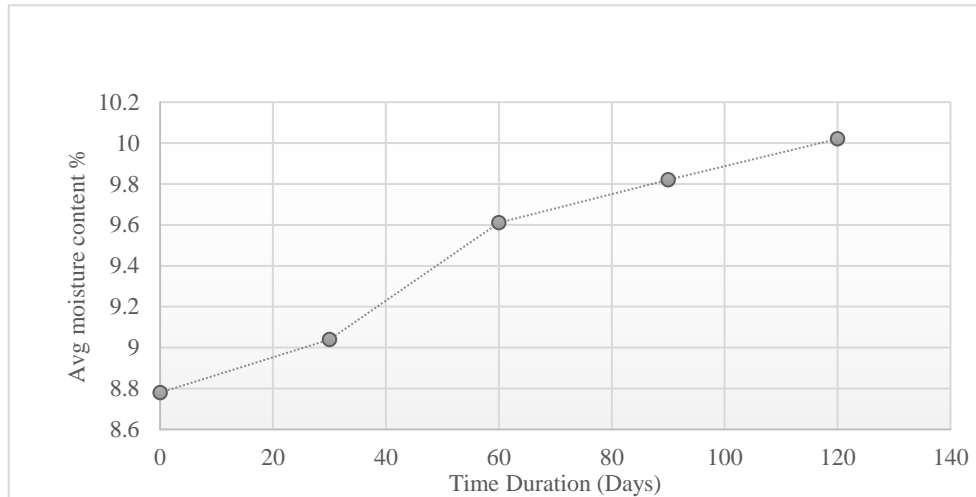

Figure 7: Changes in moisture content during storage

Based on the microbial and moisture content evaluation, it can be concluded that this composite flour mixture can be stored for 04 months period using triple laminated packages at room temperature conditions.

## 5. CONCLUSION

The second formula (i.e. 40% of Jack fruit flesh flour, 40% of Atta flour, 10% of corn flour, 7% of soy flour and 3% of Rice flour) was selected as the best composite flour mixture. The results of the proximate analysis regarding the formulae revealed that the composite flour mixture is rich in dietary fiber and protein. The product can be stored under room temperature condition for the period of four months in triple laminated packages. According to the findings of the study this composite flour mixture can be directly used as a substitute for wheat flour for the products like pittu, rotti, cakes, muffins and aggala. It was also observed that the pregelatinized form of the composite flour can be used for the preparation of string hoppers.

## REFERENCES

- AOAC, 1990. *Official methods of Analysis of AOAC International*. Virginia, New York: Academic Press.
- AOAC, 2019. *AOAC, Official Methods of Analysis of AOAC INTERNATIONAL. 21st ed.* Virginia, USA: s.n.
- Goswami, C. & Chacrabati, R., 2016. Jackfruit (*Artocarpus heterophyllus*). In: *Nutritional Composition of Fruit Cultivars*. Mymensingh, Bangladesh: s.n., pp. 317-334.
- HOSSAIN, M., KHATUN, M., MATIN, M. & DEWAN, M., 2017. POSTHARVEST LOSS ASSESSMENT OF MAJOR FRUITS GROWN IN HILL REGIONS OF BANGLADESH. *Bangladesh J. Agril. Res.*, 42(1), pp. 171-184.
- Kadam, M., ZM, M. & Salve, R., 2013. Development and Evaluation of Composite Flour for Missi roti /chapatti. *Food processing and technology*, 3(1), pp. 1-7.
- OJO, O. et al., 2017. MOISTURE-BASED SHELF LIFE ESTIMATION OF AMBIENT-STORED GRAIN FLOURS. *Journal of Research in Sciences*, 13(3), pp. 473-483.
- Olitino, H., Onimawo, I. & Egbekun, M., 2017. Effect of germination on chemical compositions, biochemical constituents and antinutritional factors of soybean (*Glycine max*) seeds.. *Journal science of food agriculture*, Volume 73, pp. 1-9.
- Pande, S. et al., 2017. Atta (Whole wheat flour) with multi-wholegrains: flour characterization, nutritional profiling and evaluation of chapati making quality. *Food science and technology*, 54(11), pp. 1-8.

- Pangborn, R., Amerine, M. & Roessler, E., 1965. *Principle of sensory evaluation of food*. New York: Academic Press.
- Ranasinghe, R., Maduwanthi, S. & Marapana, R., 2019. Nutritional and Health Benefits of Jackfruit (*Artocarpus heterophyllus* Lam.). *International Journal of Food Science*, pp. 1-12.
- Rosado, J., Cassis, L., Solano, L. & M., 2017. Effect of soy flour on nutritional, physicochemical, and sensory characteristics of gluten-free bread. *Food science and nutrition*, pp. 439-445.
- Rosado, J. L., Cassis, L., Solano, L. & A, M., 2005. Nutrient Addition to Corn Masa Flour: Effect on Corn Flour Stability, Nutrient Loss, and Acceptability of Fortified Corn Tortillas. *Food and nutrition bulletin*, 26(3).
- Wang , X. et al., 2021. Effect of whole quinoa flour substitution on the texture and in vitro starch digestibility of wheat bread. *Food Hydrocolloids*, 15 January, Volume 119, p. 106840..
- WHO, 2014. *WHO Global status report on Non Communicable Diseases*, s.l.: s.n.

# Marine Sponges as Anti-Inflammatory Drug Leads: An Overview

N.P. Ranatunga\*

Department of Natural Sciences, University College Matara, Sri Lanka

## ABSTRACT

*Inflammation is a common pathogenesis of a number of chronic diseases, for examples Type II diabetes, cardiovascular diseases, arthritis, inflammatory bowel diseases and cancer. Use of non-steroidal anti-inflammatory agents is the most commonly accepted approach to control symptoms related to inflammation. These drugs usually alter different stages of the inflammatory cascade. However, the side effects caused by these drugs cannot be ignored. There is a growing concern on the natural secondary metabolites as they are reported with less or no side effects. Of all natural resources, marine sponge-derived compounds span an extensive range of secondary metabolites with anti-inflammatory activity. The current review outlines an ample overview of the anti-inflammatory potential in marine sponge-derived compounds.*

**Keywords:** Anti-inflammatory agents, Inflammation, Marine sponges.

## 1. INTRODUCTION: OVERVIEW OF INFLAMMATION

Inflammation is a nonspecific defense mechanism in the vertebrate's immune systems against harmful stimuli, such as pathogens, toxins or irradiation, which acts by removing particular stimuli and initiating the healing process (Medzhitov, 2010). Chronic inflammation is the long lasting inflammatory process, which is the cause for the pathogenesis of many diseases, for instance cardiovascular and bowel diseases, arthritis, diabetes and cancer (Ruocco *et al.*, 2018). The cascade of inflammation starts with the physical damage or infection. When there is a tissue damage, the damaged cells start secreting several chemical mediators such as histamine, Nitric Oxide and many other to attract neutrophils to the site. This process which is called vasodilation increases the blood volume, heats the tissue and leading to redness. At the same time, leading to leakage of tissue fluid from the blood vessels, causing an accumulation of a protein-rich fluid (Delves *et al.*, 2017) resulting swelling at the damaged site. Meantime, binding of Toll like receptors (TLRs) to the external injury, activates the signaling pathway of mitogen-activated protein kinase (MAP-kinase) and the pathway of the nuclear factor kappa light chain enhancer of activated B cells (NF- $\kappa$ B) (Shoda *et al.*, 2016) which intern promotes the transcription of two major types of cytokines; tumor necrosis factor-alpha (TNF- $\alpha$ ) and interleukin (IL)-1beta (1 $\beta$ ) within the nucleus (Lawrence *et al.*, 2002) and also induces production of chemotactic factors such as IL8. These signaling molecules induce the binding and adhesion of leukocyte such as macrophages and granulocytes to the specific receptors on the epithelial cells of the blood vessel and their enrollment. These also stimulate the leukocytes to coming out from the blood circulation and move towards the spot of infection (Shoda *et al.*, 2016).

The phagocytosis process by the macrophages, also induces the evolving of reduced nicotinamide adenine dinucleotide phosphate (NADPH), which initiates the production of Reactive Oxygen Species; ROS for instance superoxide anion, hydroxyl radicals, peroxide radicals, and Reactive Nitrogen Species; RNS for example nitric oxide (Delves *et al.*, 2017). During phagocytosis oxygen consumption (respiratory burst) is increased that support ROS production by NADPH oxidase. Enzyme converts oxygen to superoxide ion ( $\bullet\text{O}^{2-}$ ). Further ROS are hydrogen peroxide ( $\text{H}_2\text{O}_2$ ), and hypochlorous acid (HClO) that are generated by the action of additional enzymes. Those are highly toxic to cells (Delves *et al.*, 2017).

Activation of mast cells metabolizes the production of arachidonic acid through the activation of enzyme phospholipase A2 (PLA2). Arachidonic acid induces the cyclooxygenase (COX) as well as the lipoxygenase (LOX) pathways, resulting the production of prostaglandins (PGs), thromboxane (TBX) and leukotrienes (LTs) respectively. PGs and TBX affect bronchial muscle contraction, platelet

---

\* Corresponding Author: E mail - [nuwandiranatunga11@gmail.com](mailto:nuwandiranatunga11@gmail.com)

aggregation and vasodilatation while LTs effect on vaso-activity, bronchoconstriction and Chemo taxis (Delves *et al.*, 2017). In chronic inflammation, the inflammatory response is prolonged and persists for a long time that leads to a continuous change of cell types present at the site of inflammation and cause a systemic response.

## 2. ANTI-INFLAMMATORY AGENTS-OVERVIEW OF MECHANISMS

Anti-inflammatory agents are used to suppress the symptoms such as pain, redness, swelling, heat and loss of functions, mainly by inhibiting the pathway of NF kB. The production of COX enzymes COX-1 plus COX-2, which synthesize prostaglandins and thromboxane, are the main mediators that maintain the level of inflammation. Anti-inflammatory agents reduce the inflammatory conditions through the reduction of the activity of specific cytokines or their receptors, blocking lymphocyte recruitment into tissues, preventing the binding of monocyte-lymphocyte co-stimulatory molecules, or reduction of B lymphocytes.

At present anti-inflammatory agents are used mostly in anti-cytokine therapies have advanced in the treatment of autoimmune diseases (Dinarello, 2010). Glucocorticoids and their synthetic derivatives are widely used to produce medications or treatments of above mentioned chronic inflammatory diseases (Lawrence *et al.*, 2002).

## 3. TYPES OF ANTI-INFLAMMATORY AGENTS

Generally, there are two major groups of anti-inflammatory agents; natural and synthetic. The synthetic anti-inflammatory drugs are grouped under distinct chemical groups such as salicylates, pyrazoles and pyrazolidines, and quinoline derivatives (Domenjoz, 1966). These synthetic drugs can be steroidal or nonsteroidal. Non-Steroidal Anti Inflammatory Drugs (NSAIDs) are more popular as therapeutic agents as they act as cyclooxygenase inhibitors (D’Orazio *et al.*, 2012), attack COX-2 pathway to block the production of prostaglandins and thromboxane. However, the inhibition of COX-1 pathway is the reason for the renal damage and gastric irritation, ulceration, adverse effects on kidney function which are the characteristic side effects of aspirin-like synthetic drugs (Bjorkman, 1998) because of these reasons, there is a great demand in the pharmaceutical industry for natural anti-inflammatory agents with less or no side effects. Of all natural anti-inflammatory agents, marine sponges are reflected as one of the best sources as they produce novel compounds with great diversity, molecular plasticity and unique therapeutic properties.

## 4. MARINE SPONGES (PHYLUM PORIFERA)

Phylum Porifera contains most primitive (without any tissues or organs) multi-cellular filter-feeders (Van Soest *et al.*, 2012) known as sponges, are evolutionarily the oldest (from the Pre Cambrian era) metazoan group (Van Soest *et al.*, 2012; Mehubub *et al.*, 2014) still a member of the marine biomass. Sponges are exclusively aquatic (Bary *et al.*, 1997) and most of them are marine (Mahdian *et al.*, 2015).

Sponges bare advanced level of bioactive mechanisms for their protection against environmental stresses like predation, competition for habitat or overgrowth by fouling organisms (Proksch,1994).

## 5. MARINE SPONGES AS DRUG LEADS

Of all naturally derived marine bio active compounds as anticancer agents were evaluated in 2011 that stated there are 18 marine-derived potential anticancer agents from sponges, out of 39 compounds. Up to date, 16 marine natural products have been produced from above anti-cancer compounds and tested under preclinical trials as novel drug candidates where Phylum Porifera contributes for six products (Newman and Cragg, 2004, Pereira *et al.*, 2019).

However, 19 known orders of marine sponges are reported to produce new compounds during last decade. Furthermore, a careful study has revealed, that high amount of novel bioactive compounds had isolated from five orders Dictyoceratida, Haplosclerida, Poecilosclerida, Halichondrida and Astrophorida. The highest quantity was reported from Dictyoceratida with 72,66,63,58 and 51 in 2008, 2004, 2009, 2001 and 2005 respectively (Mehbub *et al.*, 2014).

## 6. ANTI-INFLAMMATORY COMPOUNDS EXTRACTED FROM SPONGES

A large number of different bioactive compounds have been discovered from marine sponges with the properties of antioxidant, anti-inflammatory and radical scavenging during last few years. Shaaban *et al.*, 2012 discovered *Smenospongia*, *Niphates*, *Callyspongia*, and *Stylissa*; four marine sponges from the Red Sea at Egyptian coasts that exhibit varied inhibitory effects on oxidative stress indices in dose dependent manner.

A. R. Ortiz and group isolated pyridinium alkaloids with anti-inflammatory properties of inhibition of four secretory PLA2 (phospholipase A2) enzymes from *Spongia* sp. which was collected from the Vanuatu Islands (Ortiz *et al.*, 1993).

Contignasterol which was the first steroid anti-inflammatory compound, extracted from the marine sponge *Petrosia contignata*, in Papua. It dose dependently inhibits the anti-immunoglobulin E (anti-Ig e) stimulated release of histamine from sensitized rat mast cells (Keyzers and Davies-Coleman, 2005).

Rathee *et al.*, 2009; Keyzers and Davies-Coleman *et al.*, 2005 stated that there are four classes of anti-inflammatory alkaloid reported from marine sponges. Two are from Mediterranean shallow-water sponge *Topsentia genitrix* as topsentin (Glaser *et al.*, 1994) and other two from Australia and Guam as bromotopsentin (Crews *et al.*, 1985) and Bastadins-4 from the marine sponge *Ianthella basta*. The same study states, terpenoid anti-inflammatory compounds were also isolated from marine sponges as thirteen anti-inflammatory sesquiterpenes, ten anti-inflammatory diterpenes and several sesterterpenes.

Most of the studies have revealed the anti-inflammatory activity of marine sponges with respect to protein denaturation, heat and hypotonicity induced erythrocyte membrane stabilization and NO radical scavenging while comparing the IC<sub>50</sub> values with that of standard drug references.

The study on marine sponges scattered in Mediterranean coasts of Turkey expressed moderate NO scavenging activity for five different sponge species *Agelas oroides*, *Dysidea avara*, *Ircinia spinulosa* and *Axinella damicornis*, *Axinella cannabina* (Aktas *et al.*, 2013).

Interestingly sponge extracts of *Stylissa carteri*, *Axinella* sp. and *Phakellia* sp. from western coast resulted higher potency in NO radical scavenging than the respective standard (De Silva *et al.*, 2018). The similar experiment indicated effective stabilization of proteins against heat for sponge species of *Stylissa carteri*, *Axinella* sp. and *Phakellia* sp. It is well accepted that marine sponges harbor an array of secondary metabolites which may responsible for their respective bioactivities (David, 2007; Milianuskas *et al.*, 2004)

The resulted anti-inflammatory activity can be varying according to the species and some possible reasons. A major reason is the differences of locality and the temporal changes of the sponge species and differences of habitats. Different marine sponges from diverse localities poses number of secondary metabolites with varying anti-inflammatory activities. This effect of the locality may be owing to the endophytic microorganisms living with the sponges or the composition of the water around the sampling areas (Margot *et al.*, 2002; Sarma *et al.*, 2005). The biosynthesis of sponge's secondary metabolites is influenced by the seasonal changes of various abiotic factors such as temperature, salinity and pH as well as biotic factors like epifaunal diversity and morphology of sponges (Chairman *et al.*, 2012).

## 7. CONCLUSION AND FUTURE PERSPECTIVES

The basis of marine pharmacology is the potency of ocean to lead to novel therapeutic agents. Natural products-derived drugs have to overcome some difficulties during marine drug discovery, to reach the success, such as sufficient resourcing and problems related to structural complexity (Gerwick and Moore, 2012). Most of the approved marine derived drugs are on the way of the drug discovery pipeline. The difficulty in the exact identification may be a major cause for the insufficient studies on sponge bioactive compounds. Other than depending on spicules and skeleton analysis for the identification of sponge species precise species identification can be done by DNA barcoding.

Being a biological hot-spot, along with the Western Ghats of India, Sri Lanka harbors a rich biodiversity, in terrestrial and aquatic environments where most of the species are not being

taxonomically identified. Similarly, prominent species diversity of Sri Lankan marine fauna, undoubtedly create a massive chemical diversity, resulting these organisms a gold mine to natural product chemists. To date, marine spongology and their bioactive compounds remain at its infancy in Sri Lanka, resulting a large research gap.

## ACKNOWLEDGMENT

The author would like to thank Dr. K. V. K. Gunathilake, Department of Zoology, Faculty of Applied Sciences, University of Sri Jayewardenepura, Sri Lanka for her immense support extended for this study.

## REFERENCES

- Aktas, N., Genc, Y., Gozcelioglu, B., Konuklugil, B. and Harput, U.S., 2013. Radical scavenging effect of different marine sponges from Mediterranean coasts. *Records of Natural Products*, 7(2), p.96.
- Bary, K., Elamraoui, B. and Bamhaoud, T., 1997. Chemical characterization of *Cliona viridis*: Sponge of Atlantic Moroccan Coast. *International Journal of Innovation and Scientific Research*, 26, pp.14-22.
- Bjorkman, D.J., 1998. The effect of aspirin and nonsteroidal anti-inflammatory drugs on prostaglandins. *The American journal of medicine*, 105(1), pp.8S-12S.
- Chairman, K., Singh, A.R. and Alagumuthu, G., 2012. Cytotoxic and antioxidant activity of selected marine sponges. *Asian Pacific Journal of Tropical Disease*, 2(3), pp.234-238.
- Crews, P., Bescansa, P. and Bakus, G.J., 1985. A non-peroxide norsesterterpene from a marine sponge *Hirtios erecta*. *Experientia*, 41(5), pp.690-691.
- D’Orazio, N., Gammone, M.A., Gemello, E., De Girolamo, M., Cusenza, S. and Riccioni, G., 2012. Marine bioactives: Pharmacological properties and potential applications against inflammatory diseases. *Marine drugs*, vol.10. no.4, pp. 812-833.
- David, S., 2007. Studies force new view on biology of flavonoids. *Biol Med*, 541, pp.737-87.
- De Silva, D.P.M., Bertollino, M. and Gunathilaka, K.V.K., 2018. evaluation of in vitro anti-inflammatory activity of five selected marine sponges against denaturation of protein-a pilot study. *International Journal of Current Research*, 10(4), pp. 68349-68353.
- Delves, P.J., Martin, S.J., Burton, D.R. and Roitt, I.M., 2017. *Roitt's essential immunology*. John Wiley & Sons.
- Dinarello, C.A., 2010. Anti-inflammatory agents: present and future. *Cell*, 140(6), pp.935-950.
- Domenjoz, R., 1966. Synthetic anti-inflammatory drugs: Concepts of their mode of action. *Advances in pharmacology*, 4, pp.143-217.
- Gerwick, W.H. and Moore, B.S., 2012. Lessons from the past and charting the future of marine natural products drug discovery and chemical biology. *Chemistry & biology*, 19(1), pp.85-98.
- Glaser, K.B., Sung, M.L., Lock, Y.W., Bauer, J., Kubrak, D. and Kreft, A., 1994. Analogs of the marine natural product scalaradial lacking the  $\alpha$ ,  $\beta$ -unsaturated aldehyde: effects on human synovial fluid phospholipase A2 and macrophage lipid mediator production. *Bioorganic & Medicinal Chemistry Letters*, 4(15), pp.1873-1878.
- Keyzers, R.A. and Davies-Coleman, M.T., 2005. Anti-inflammatory metabolites from marine sponges. *Chemical Society Reviews*, vol.34. no.4, pp. 355-365.
- Lawrence, T., Willoughby, D.A. and Gilroy, D.W., 2002. Anti-inflammatory lipid mediators and insights into the resolution of inflammation. *Nature Reviews Immunology*, 2(10), pp.787-795.
- Mahdian, D., Iranshahy, M., Shakeri, A., Hoseini, A., Yavari, H., Nazemi, M. and Iranshahi, M., 2015. Cytotoxicity evaluation of extracts and fractions of five marine sponges from the Persian Gulf and HPLC fingerprint analysis of cytotoxic extracts. *Asian Pacific Journal of Tropical Biomedicine*, 5(11), pp.896-901.
- Margot, H., Acebal, C., Toril, E., Amils, R. and Puentes, J.F., 2002. Consistent association of crenarchaeal Archaea with sponges of the genus *Axinella*. *Marine Biology*, 140(4), pp.739-745.
- Medzhitov, R., 2010. Inflammation 2010: new adventures of an old flame. *Cell*, 140(6), pp.771-776.
- Mehbub, M.F., Lei, J., Franco, C. and Zhang, W., 2014. Marine sponge derived natural products between 2001 and 2010: trends and opportunities for discovery of bioactives. *Marine drugs*, 12(8), pp.4539-4577.

- Miliauskas, G., Venskutonis, P.R. and Van Beek, T.A., 2004. Screening of radical scavenging activity of some medicinal and aromatic plant extracts. *Food chemistry*, 85(2), pp.231-237.
- Newman, D.J. and Cragg, G.M., 2004. Marine natural products and related compounds in clinical and advanced preclinical trials. *Journal of natural products*, 67(8), pp.1216-1238.
- Ortiz, A.R., Pisabarro, M.T. and Gago, F., 1993. Molecular model of the interaction of bee venom phospholipase A2 with manolide. *Journal of medicinal chemistry*, 36(13), pp.1866-1879.
- Pereira, R.B., Evdokimov, N.M., Lefranc, F., Valentão, P., Kornienko, A., Pereira, D.M., Andrade, P.B. and Gomes, N.G., 2019. Marine-derived anticancer agents: Clinical benefits, innovative mechanisms, and new targets. *Marine drugs*, 17(6), p.329.
- Proksch, P., 1994. Defensive roles for secondary metabolites from marine sponges and sponge-feeding nudibranchs. *Toxicon*, 32(6), pp.639-655.
- Rathee, P., Chaudhary, H., Rathee, S., Rathee, D., Kumar, V. and Kohli, K., 2009. Mechanism of action of flavonoids as anti-inflammatory agents: a review. *Inflammation & Allergy-Drug Targets (Formerly Current Drug Targets-Inflammation & Allergy) (Discontinued)*, 8(3), pp.229-235.
- Ruocco, N., Albarano, L., Capone, F., Costantini, S. and Costantini, M., 2018. Anti-Inflammatory Agents from Marine Sponges: An Update.
- Sarma, N.S., Krishna, M. and Rao, S.R., 2005. Sterol ring system oxidation pattern in marine sponges. *Marine Drugs*, 3(3), pp.84-111.
- Shaaban, M., Abd-Alla, H.I., Hassan, A.Z., Aly, H.F. and Ghani, M.A., 2012. Chemical characterization, antioxidant and inhibitory effects of some marine sponges against carbohydrate metabolizing enzymes. *Organic and medicinal chemistry letters*, 2(1), pp.1-12.
- Shoda, H., Hanata, N., Sumitomo, S., Okamura, T., Fujio, K. and Yamamoto, K., 2016. Immune responses to Mycobacterial heat shock protein 70 accompany self-reactivity to human BiP in rheumatoid arthritis. *Scientific reports*, 6(1), pp.1-10.
- Van Soest, R.W., Boury-Esnault, N., Vacelet, J., Dohrmann, M., Erpenbeck, D., De Voogd, N.J., Santodomingo, N., Vanhoorne, B., Kelly, M. and Hooper, J.N., 2012. Global diversity of sponges (Porifera). *PLoS one*, 7(4), p.e35105.



# Non-Metalize Composite Materials on the Shelf Life of Hard Dough Plain Biscuits

Praveen Kanakarathna\*, U.A.S.K. Edirisinghe

Department of Agriculture and Food Technology, University of Vocational Technology, Sri Lanka

## ABSTRACT

*This study aimed to assess the availability of suitable non-metalize different packing materials of the Sri Lankan biscuit industry to evaluate quality factors of the packing materials shelf life of the packaging product, and the cost factor. Around 10 non-metallic composite wrapping materials are commercially available. The Marie product under went evaluations with different non-metallic composite materials. When the composite materials were analysed, 50% of them included BOPP and combined with CPP material. The lowest permeability for water vapour transmission rate was indicated by code E (PVDC Coated 30 BOPP+25 CPP) as  $0.40 \pm 0.006$  g/m<sup>2</sup>.day at the thickness of 57µm. The lowest moisture increment (0.0096) was less than 4%, the lowest ( $\Delta E$ ) colour value, and water activity (0.0012) which were less than 0.4 were recorded from code E material within 120 days. Highest acceptability values were reported from the code E wrapper biscuits for the 4 month period. Microbiological aspect (Total Plate Count  $1.73 \times 10^3$ ) of the code E material was at satisfactory level within the standard range. Though, the cost of the material was moderate, the other suitable factors were satisfied for code E material. This study revealed that code E (PVDC Coated 30 BOPP+25 CPP) wrapper could be recommended to be used as the most effective non-metallic composite material for biscuit manufacturing. Printability and stability of the labels of the wrapping material would be recommended for further analysis in future.*

**Keywords:** Biscuit, Non-metalize composite materials, Shelf life.

## 1. INTRODUCTION

Biscuit is the cheapest processed food on the market, and its various packaging sizes make it ideal for travel and family use. Biscuits are small baked goods made with flour, sugar, and fat that typically have a moisture content of less than 4% and a shelf life of 6 months or more (Manley, 2000). According to Manley (2000), shelf life is an important characteristic of any food, but other factors such as moisture, water activity, and proper packaging will also influence the final product. Moisture is a food ingredient that has an impact on food safety, stability, quality, and physical properties (Lewicki, 2004).

Packaging ensures that the product is delivered to the end user in the best possible way and under the best possible conditions (Robertson, 2011). The primary packaging comes into direct contact with the contained product. It serves as the first and, in most cases, the primary protective barrier. To achieve the expected shelf life, most foods rely on specific packaging. The shelf life of biscuits is determined by the inherent product characteristics, barrier properties, and other functional properties of the packaging materials, packaging operations used distribution and storage methods used, and final economic considerations.

Food packaging is important in protecting products from macroscopic and microbial contamination, preventing product scaling, water loss or increase, and preventing products from being exposed to oxygen and processing in the modern world. Easier packaging can also boost sales by establishing a brand image that buyers recognize and focuses on better printing quality and glossiness. The main function of food packaging is to minimize reactions that affect the stability of the products contained in the food packaging. In most cases, under normal food storage and distribution conditions, the presence of gaseous reactants (water vapour, oxygen) in the environment severely limits stability (Rizvi, 1981). Therefore, the transfer rate of such reactants through the partial barriers of the packaging wall may be

---

\* Corresponding Author - Email: [praveenkanakarathna80@gmail.com](mailto:praveenkanakarathna80@gmail.com)

the limiting factor for shelf life (Gawith and Robertson, 2000; Ahvenainen, 2003). It has been found that membrane permeability is more important than seal leakage (Chung *et al.*, 2003)

Some factors of the packaging materials were affected to change desired quality of biscuit product to the consumer at the end. During the distribution process, the food quality will be reduced due to biological, chemical and physical factors. Therefore, food packaging can help extend shelf life and maintain food quality and safety (Jung, 2005). Thus, consumer demand, wastage and financial matters also affected. Finding out the most suitable cost effective product packaging concept is needed as remedy. In this study mainly focused to determine barrier properties of selected packaging materials of the biscuit products.

## 2. OBJECTIVE

### 2.1. General Objective

To evaluate the shelf life of hard dough plain biscuits by using available non-metalized packing materials in the Sri Lankan biscuit industry

### 2.2. Specific Objective

- To identify the non-metalize packing materials available in biscuit industry in Sri Lanka.
- To determine the quality factors of packing materials.
- To determine the shelf life of the packaging packeted product
- To evaluate the cost effectiveness of the composite materials.

## 3. MATERIALS AND METHODS

The experiment was carried out in the R & D laboratory of the leading biscuit manufacturing company and the laboratory of the Department of Agriculture and Food Technology, University of Vocational Technology, Rathmalana, Sri Lanka.

### 3.1. Material and Sample Selection

As a preliminary study the Non-metalize composite materials, which are used to biscuit packaging, were detected and collected from the different suppliers according to the availability in Sri Lankan market. The ten different types of materials were commercialized to the biscuit packaging mentioned in the table 01.

Table 01: Non-Metalize Composite Materials with the Code Number.

No	CODE	Material
1	A	30 BOPP+25 BOPP
2	B	12 PET+15 Nylon+25 CPP
3	C	12 PET+ 25 LD
4	D	12 PET+25 CPP
5	E	PVDC Coated 30 BOPP+25 CPP
6	F	30 BOPP+25 CPP
7	G	20 BOPP+25 CPP
8	H	20 BOPP+12 PET+25 CPP
9	I	12 PET+40 CPP
10	J	15 Nylon+ 80 LD

Selected plain hard dough type (Marie) branded biscuit samples were wrapped by identified wrapper materials and sealed by using manual handling of industrial sealing machine. It was carried out according to operational instruction of the “Constant Heat Sealer” (Model – ME 400 CFN- China). Machine temperature range is 30 °C – 200 °C.

### 3.2. Sample Size

50 samples of each biscuit pack (75 grammes of biscuit per pack) wrapped with ten different non-metalized composite materials as mentioned in the Table 02.

Table 02: Non-Metalize Composite Material Sample Size

No	CODE	Material	No of sample (75 gram per pack)
1	A	30 BOPP+25 BOPP	50
2	B	12 PET+15 Nylon+25 CPP	50
3	C	12 PET+ 25 LD	50
4	D	12 PET+25 CPP	50
5	E	PVDC Coated 30 BOPP+25 CPP	50
6	F	30 BOPP+25 CPP	50
7	G	20 BOPP+25 CPP	50
8	H	20 BOPP+12 PET+25 CPP	50
9	I	12 PET+40 CPP	50
10	J	15 Nylon+ 80 LD	50

### 3.3. Determination of Thickness

4 cm x 4 cm cuts of each wrapper material were used to determine the wrapper thickness. The digital micrometer (Mitutoyo 293-340-30-Japan) was used to obtain the reading from the middle of each cut. Average of 3 reading from different pieces of a material was reported as the wrapper thickness of particular wrapper material.

### 3.4. Determination of Water Vapour Transmission Rate (Wvtr)

The sample size (108 mm x 108 mm) from the selected films were cut as per the recommended template size. Testing of WVTR was carried out according to the test method of the “ASTM F 1249” by using the “labthink” C390H-China Water Vapour Transmission Rate Test System.

### 3.5. Determination of Sealing of Wraed Biscuits Packets

Testing of sealing was carried out according to the operational instructions of the “SealTick” (Model – TSE6086B- Package integrity tester-Australia) packet sealing test machine.

### 3.6. Determination of Quality Factor of Non-Metalize Composite Materials

Mainly physicochemical parameters were concerned as quality indicators of the packed biscuit materials.

#### 3.6.1. Determination of Moisture Content

The moisture content of the sample was determined based on the SLS 251:2010 Sri Lanka standard.

The Related data was analyzed using formula given by SLS 251:2010.

#### 3.6.2. Determination of Acidity of Extracted Fat

The acidity of extracted fat of the sample was detected by using the method of SLS 251:2010.

### 3.6.3. Determination of Water Activity

The water activity ( $a_w$ ) of the sample was measured using the “Aqua Lab” (Model – 4 TE-USA) water activity meter and method was followed as per operational guidelines.

### 3.6.4. Determination of Color Values

The values of surface color of biscuits in terms of color difference ( $\Delta E$ ) and present whiteness were recorded using Chroma Meter (CR-400- Konica Minolta - Japan) as per operational guidelines.

### 3.6.5. Determination of Organoleptic Parameters

For this study, trained sensory panel was used to detect organoleptic parameters for the products concerning with sensory attributes including aroma, mouth feel, taste and also overall acceptability. Samples were evaluated on initial day of the manufacturing and one month intervals continuing four month periods. The sensory attributes were recorded based on 5-point hedonic scale and analysed using the Kruskal-Wallis non parametric ANOVA method. Mean separation was also performed for the significant.

## 3.7. Determinations Microbiological Parameters of Packed Biscuit Samples

### 3.7.1. Total Plate Count (Tpc)

Testing of Total Plate Count (TPC) was carried out according to the test method of SLS 516 Part 1/section 1:2013 (ISO 4833-1:2013). This was tested end of the 4<sup>th</sup> Month for selected samples.

## 4. RESULTS AND DISCUSSION

### 4.1. Determination of Thickness and Wvtr

The results (Table 03) showed lowest WVTR value is recorded from code E (PVDC Coated 30 BOPP+25 CPP) as 0.40 g/m<sup>2</sup>.day against with the thickness of 57  $\mu\text{m}$ . The WVTR values are second lowest for material code H (20 BOPP+12 PET+25 CPP) has third lowest for material code A (30 BOPP+25 BOPP) given as 0.65 and 0.71 g/m<sup>2</sup>.day respectively. Though the thickness of the material code J (15 Nylon+ 80 LD) is highest (101  $\mu\text{m}$ ), the WVTR value also highest as 5.50 g/m<sup>2</sup>.day. Considering the components, most of the BOPP containing materials are indicated less than 1.0 WVTR value except material code G.

Table 03: Thickness and WVTR of Selected Non-Metalized Composite Materials

No	Code	Composite Materials	Thickness ( $\mu\text{m}$ )	WVTR g/m <sup>2</sup> .day
1	A	30 BOPP+25 BOPP	57	0.71 $\pm$ 0.006
2	B	12 PET+15 Nylon+25 CPP	55	1.90 $\pm$ 0.006
3	C	12 PET+ 25 LD	45	3.32 $\pm$ 0.000
4	D	12 PET+25 CPP	39	2.54 $\pm$ 0.000
5	E	PVDC Coated 30 BOPP+25 CPP	57	0.40 $\pm$ 0.006
6	F	30 BOPP+25 CPP	57	0.80 $\pm$ 0.000
7	G	20 BOPP+25 CPP	47	1.32 $\pm$ 0.006
8	H	20 BOPP+12 PET+25 CPP	59	0.65 $\pm$ 0.006
9	I	12 PET+40 CPP	55	1.75 $\pm$ 0.010
10	J	15 Nylon+ 80 LD	101	5.50 $\pm$ 0.006

## 4.2. Selection of Suitable Packaging Materials as Per the Sealability Test Results

Sealability strength of the biscuit sample was detected using the Constant Heat Sealer machine, Code C and Code J samples were recorded as poor sealing properties among ten different composite materials (Table 04). Thus, for further analysis decided to continue with other samples (A,B,D,E,F,G,H & I) in this study.

Table 04: Sealability Result of Non-Metalize Composite Materials Packeted Biscuit Samples

No	Code	Composite Materials	Weight of the packet	Sealability Pass/Fail
1	A	30 BOPP+25 BOPP	75g pkts	Pass
2	B	12 PET+15 Nylon+25 CPP	75g pkts	Pass
3	C	12 PET+ 25 LD	75g pkts	Fail
4	D	12 PET+25 CPP	75g pkts	Pass
5	E	PVDC Coated 30 BOPP+25 CPP	75g pkts	Pass
6	F	30 BOPP+25 CPP	75g pkts	Pass
7	G	20 BOPP+25 CPP	75g pkts	Pass
8	H	20 BOPP+12 PET+25 CPP	75g pkts	Pass
9	I	12 PET+40 CPP	75g pkts	Pass
10	J	15 Nylon+ 80 LD	75g pkts	Fail

## 4.3. Shelf-Life Evaluation of Sealed Biscuit Samples

### 4.3.1 Evaluation of Moisture Content of the Sealed Biscuit Samples

Out of ten biscuit samples, eight packets were selected for the shelf-life evaluation. Figure 01 shows that the lowest increment ( $m=0.0096$ ) of moisture ( $2.2\pm 0.2\%$ ) was recorded in the products, which have packed under the code E material, while the highest increment ( $m=0.0414$ ) of moisture content ( $5.5\%\pm 0.2$ ) was reported code D material in the period of four months.

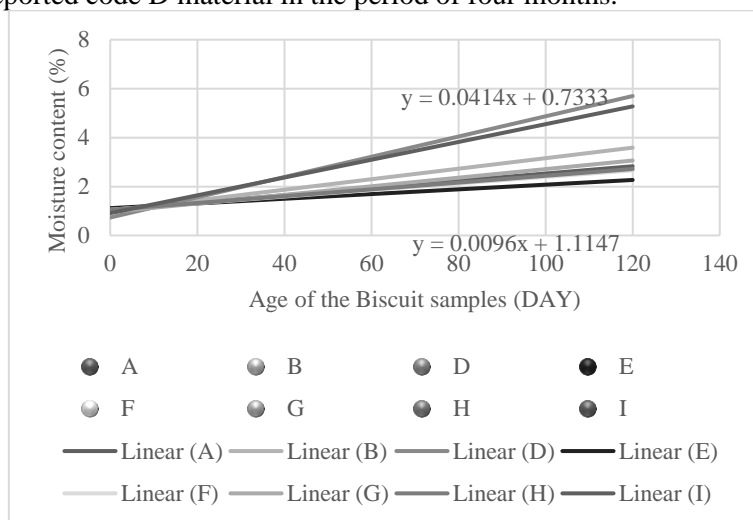

Figure 01: Change of the Moisture Content % with the Age of Biscuit Samples

### 4.3.2. Evaluation of Acidity of Extracted Fat the Sealed Biscuit Samples

As per the current practice and standard, the acidity of extracted fat detected based on the level of oleic acid of the biscuit products, which should not to be exceeded 1.0%. Figure 02 expresses, the highest increment ( $m=0.0054$ ) of the extracted fat content was exceeded less than 100 days of the code I material. Thus, the code I material is indicated lowest shelf life. Based on the increment value

( $m=0.0025$ ) and percentage of extracted fat level (0.85%) the highest estimated shelf life was observed Code E material in the period of 120 days.

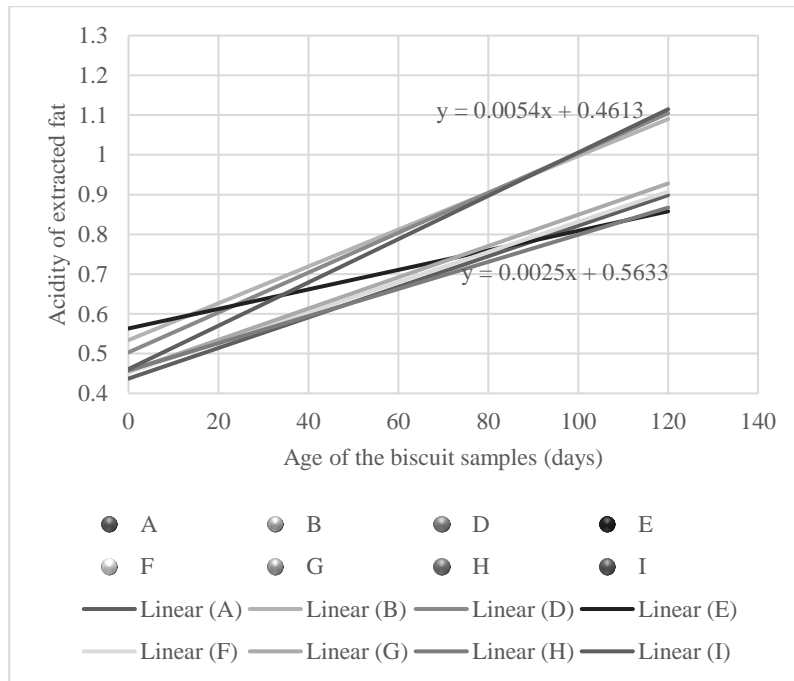

Figure 02: Change of the Acidity of Extracted Fat with the Age of Biscuit Samples

#### 4.3.3. Determination of Water Activity of the Biscuit Samples

According to the figure 03, the lowest increment ( $m = 0.0012$ ) of water activity level ( $0.25 \pm 0.02$ ) was observed in the products which have packed by using code E material while the highest increment ( $m=0.0028$ ) of water activity level ( $0.45 \pm 0.02$ ) was recorded code D material.

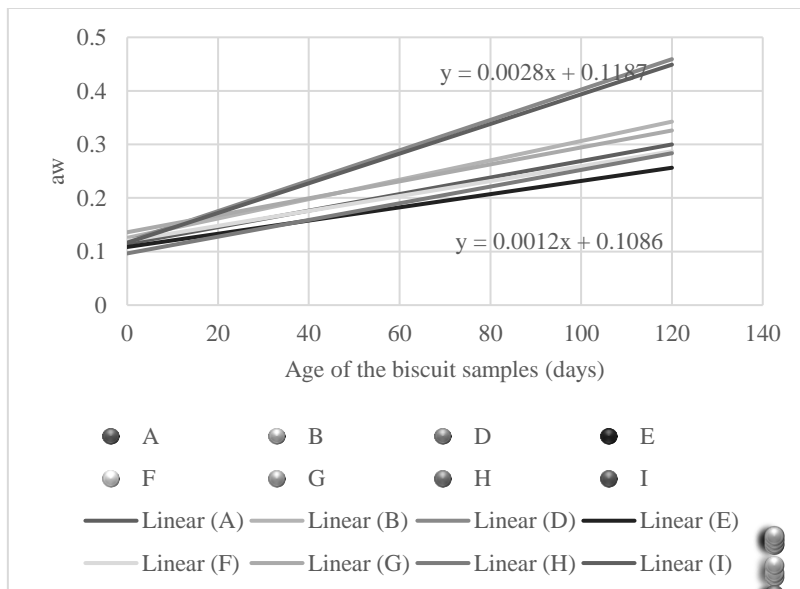

Figure 03: Change of the Water Activity with the Age of Biscuit Samples

### 4.3.4. Determination of Biscuit Colour Variation

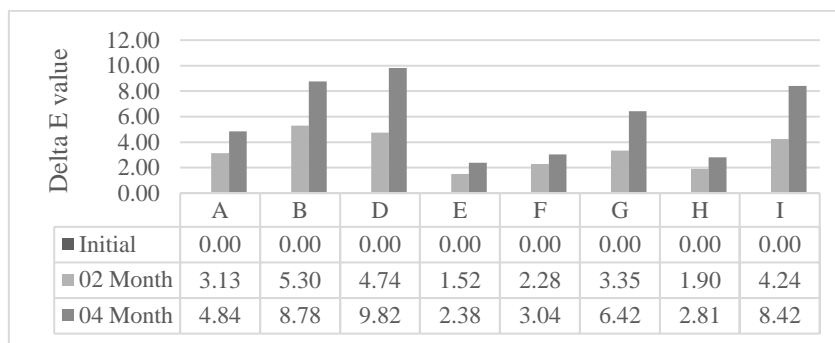

Figure 04: The Colour Difference ( $\Delta E$ ) Values of the Biscuit Top Side

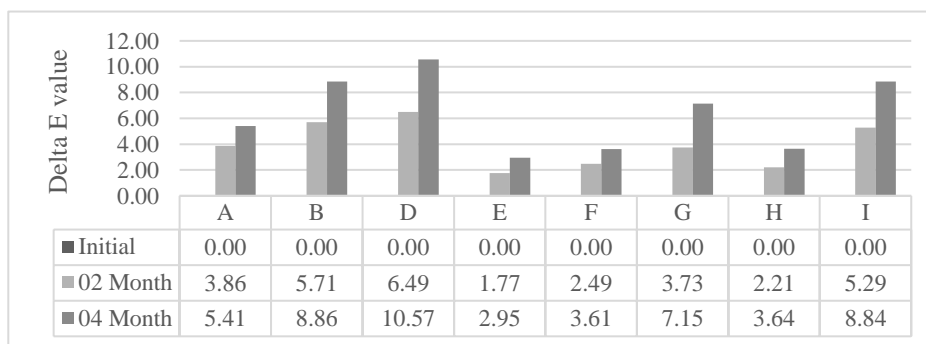

Figure 05: The Colour Difference ( $\Delta E$ ) Values of the Biscuit Bottom Side

Color is also one of important quality attributes for consumer acceptance of biscuit products. As per the figure 04 and 05, it has observed lowest ( $\Delta E$ ) value on top and bottom side of the biscuit colour which have packed by using code E material and followed by F and H as second and third rank respectively. Hence, the code E material indicated good barrier properties than other materials

### 4.3.5. Determination of Sensory Evaluation of the Biscuit Samples

Table 05 shows, which the mean values of the sensory evaluation test results, which have indicated highest positive response to the Code E wrapper material product and followed by the code F material product. Thus, the overall acceptability was highest in wrapper code E material, whereas materials D, I and B were the lowest after evaluating the four-month storage.

Table 05: Sensory Characteristics Evaluated at the Shelf-Life Study

Attribute	Biscuit samples code	Keeping quality with time after packaging				
		initial	Month1	Month2	Month3	Month4
Aroma	A	5 <sup>a</sup>	4 <sup>b</sup>	3 <sup>bc</sup>	2 <sup>d</sup>	2 <sup>e</sup>
	B	5 <sup>a</sup>	4 <sup>b</sup>	3 <sup>c</sup>	3 <sup>cd</sup>	2 <sup>e</sup>
	D	5 <sup>a</sup>	3 <sup>b</sup>	3 <sup>bc</sup>	2 <sup>d</sup>	1 <sup>e</sup>
	E	5 <sup>a</sup>	5 <sup>a</sup>	5 <sup>a</sup>	4 <sup>b</sup>	4 <sup>b</sup>
	F	5 <sup>a</sup>	4 <sup>b</sup>	4 <sup>bc</sup>	3 <sup>cd</sup>	3 <sup>de</sup>
	G	5 <sup>a</sup>	3 <sup>bc</sup>	3 <sup>c</sup>	2 <sup>cd</sup>	2 <sup>de</sup>
	H	5 <sup>ab</sup>	4 <sup>bc</sup>	3 <sup>c</sup>	4 <sup>de</sup>	3 <sup>e</sup>
	I	5 <sup>a</sup>	3 <sup>b</sup>	2 <sup>c</sup>	2 <sup>de</sup>	1 <sup>e</sup>
	Mouth feel	A	5 <sup>a</sup>	4 <sup>b</sup>	3 <sup>c</sup>	2 <sup>d</sup>
B		5 <sup>a</sup>	4 <sup>bcd</sup>	3 <sup>cd</sup>	3 <sup>d</sup>	1 <sup>e</sup>
D		5 <sup>a</sup>	3 <sup>b</sup>	2 <sup>cd</sup>	2 <sup>de</sup>	1 <sup>e</sup>
E		5 <sup>bc</sup>	5 <sup>bc</sup>	5 <sup>cd</sup>	4 <sup>de</sup>	4 <sup>e</sup>
F		5 <sup>a</sup>	4 <sup>bc</sup>	4 <sup>cd</sup>	4 <sup>d</sup>	3 <sup>e</sup>
G		5 <sup>a</sup>	4 <sup>b</sup>	3 <sup>cd</sup>	3 <sup>d</sup>	2 <sup>e</sup>
H		5 <sup>ab</sup>	5 <sup>b</sup>	4 <sup>cd</sup>	3 <sup>de</sup>	3 <sup>e</sup>
I		5 <sup>a</sup>	3 <sup>b</sup>	2 <sup>c</sup>	1 <sup>de</sup>	1 <sup>e</sup>
Taste		A	5 <sup>a</sup>	4 <sup>b</sup>	3 <sup>c</sup>	2 <sup>de</sup>
	B	5 <sup>a</sup>	4 <sup>b</sup>	3 <sup>cd</sup>	3 <sup>d</sup>	1 <sup>e</sup>
	D	5 <sup>a</sup>	2 <sup>b</sup>	1 <sup>cde</sup>	1 <sup>d</sup>	1 <sup>e</sup>

Overall acceptability	E	5 <sup>abc</sup>	5 <sup>bc</sup>	5 <sup>c</sup>	4 <sup>de</sup>	4 <sup>e</sup>
	F	5 <sup>a</sup>	4 <sup>bcd</sup>	4 <sup>cd</sup>	4 <sup>d</sup>	3 <sup>e</sup>
	G	5 <sup>a</sup>	4 <sup>bd</sup>	3 <sup>cd</sup>	3 <sup>d</sup>	2 <sup>e</sup>
	H	5 <sup>a</sup>	4 <sup>b</sup>	3 <sup>cd</sup>	4 <sup>d</sup>	3 <sup>e</sup>
	I	5 <sup>a</sup>	3 <sup>b</sup>	2 <sup>c</sup>	1 <sup>de</sup>	1 <sup>e</sup>
	A	5 <sup>a</sup>	4 <sup>b</sup>	3 <sup>c</sup>	2 <sup>de</sup>	2 <sup>e</sup>
	B	5 <sup>a</sup>	4 <sup>b</sup>	3 <sup>cd</sup>	3 <sup>d</sup>	1 <sup>e</sup>
	D	5 <sup>a</sup>	2 <sup>b</sup>	1 <sup>ode</sup>	1 <sup>de</sup>	1 <sup>e</sup>
	E	5 <sup>abc</sup>	5 <sup>b</sup>	5 <sup>c</sup>	4 <sup>de</sup>	4 <sup>e</sup>
	F	5 <sup>a</sup>	4 <sup>bcd</sup>	4 <sup>cd</sup>	4 <sup>d</sup>	3 <sup>e</sup>
	G	5 <sup>a</sup>	4 <sup>b</sup>	3 <sup>cd</sup>	3 <sup>d</sup>	2 <sup>e</sup>
H	5 <sup>a</sup>	4 <sup>b</sup>	3 <sup>cd</sup>	4 <sup>d</sup>	3 <sup>e</sup>	
I	5 <sup>a</sup>	3 <sup>b</sup>	2 <sup>c</sup>	1 <sup>de</sup>	1 <sup>e</sup>	

**4.4. Microbiological Analysis of Selected Biscuit Samples**

All selected biscuit samples TPC values were within the standard limit. (SLS 251:2010, 1\*10<sup>3</sup> - 1\*10<sup>4</sup> Cfu/g).

**4.5 Analysis of Cost Factor of Non-Metalize Composite Material**

As per the Figure 06, shows that the highest cost was observed for code B material and next to the code H material. The average cost calculated for 1000m length reel. Least cost was recorded for code D and code G material.

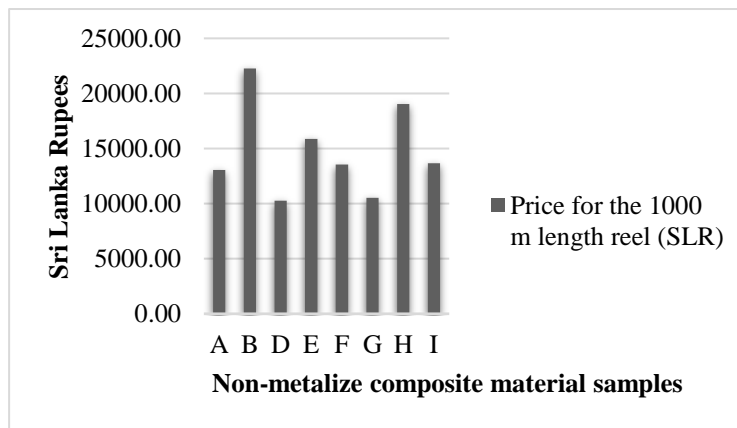

Figure 06: Average Cost of Wrapper Materials (Non-Metalize Composite) in a Month

Assuming the monthly requirements of the wrapper materials as 100 reel, the mean value of the cost for 1000 m length is SLR 15,000.00. Lowest price was recorded for wrapper material D and whereas the highest price was recorded for wrapper material B, which has been added 53% to the mean value as an additional cost. Code E wrapper material has a medium cost, which is added 7% with to the average cost comparatively with other materials. Analysing with all factors shown in Table 06, wrapper material E was considered as the best material and followed by F and H as second and third rank respectively.

Table 06: Ranking Packaged Wrapping Materials Based on Examined Factors

Code	Permeation WVTR g/m <sup>2</sup> .day	Overall Acceptance (after 4 month)	TPC count (std.10 <sup>3</sup> -10 <sup>4</sup> ) Cfu/g	Price SLR.(1000 m) (mean 15,000/=)	Rank
A	0.71	2 <sup>e</sup>	1.90 × 10 <sup>3</sup>	13,000 (-13%)	4
B	1.90	1 <sup>e</sup>	1.95 × 10 <sup>3</sup>	23,000 (+53%)	8
D	2.54	1 <sup>e</sup>	2.40 × 10 <sup>3</sup>	10,000 (-33%)	7
E	0.40	4 <sup>e</sup>	1.73 × 10 <sup>3</sup>	16,000 (+7%)	1
F	0.80	3 <sup>e</sup>	1.86 × 10 <sup>3</sup>	14,000 (-7%)	2
G	1.32	2 <sup>e</sup>	1.96 × 10 <sup>3</sup>	11,000 (-26%)	5



<b>H</b>	0.65	3 <sup>e</sup>	$1.82 \times 10^3$	19,000 (+26%)	3
<b>I</b>	1.75	1 <sup>e</sup>	$2.10 \times 10^3$	14,000 (-7%)	6

## 5. CONCLUSION AND RECOMMENDATION

### 5.1 Conclusion

Currently around 10 non-metallic composite wrapping materials are commercially available in packaging industry. When analysing the composite materials, 50% of them are included BOPP at least 20µm thickness and most of the BOPP combined with CPP material. Those materials are commonly used for biscuit manufacturing industry. Most critical factor of the shelf life is recognized as WVTR, which was lowest for the wrapper material of E with the combination of PVDC Coated 30 BOPP+25 CPP. Overall acceptability was highest in wrapper code E material and lowest for WVTR, which was the highest moisture barrier property with acceptable range of the TPC value. Code E wrapper material was observed lowest ( $\Delta E$ ) values both top & bottom side of the biscuit.

Also code E wrapper material has a significant effect to increase the shelf life of the Marie biscuit products, with respect to physio-chemical parameters and organoleptic attributes studied. Though the wrapper cost of E material has a medium level the most effective wrapping material solution for the Marie products is Code E. For further studies are needed to determine the printability and stability of the printed wrapper of the Code E (PVDC Coated 30 BOPP+25 CPP) wrapper with other two ranking code materials of F (30 BOPP+25 CPP) and H (20 BOPP+12 PET+25 CPP) should be studied.

### REFERENCES

- Ahvenainen, R., 2003. Active and intelligent packaging: an introduction. In *Novel food packaging techniques* (pp. 5-21). Woodhead Publishing.
- Chung, D., Papadakis, S.E. and Yam, K.L., 2003. Evaluation of a polymer coating containing triclosan as the antimicrobial layer for packaging materials. *International journal of food science & technology*, 38(2), pp.165-169.
- Gawith, J.A. and Robertson, T.R., 2000. Wrapping up packaging technology. *Journal of the Home Economics Institute of Australia*, 7(2), pp.6-14.
- Jung H.H., 2005, New technologies in food packaging overview, Innovation in Food Packaging, Elsevier Science & Technology Books, pp.3-10
- Lewicki, P.P., 2004. Water as the determinant of food engineering properties. A review. *Journal of Food Engineering*, 61, pp. 483-495
- Manely, D., 2000, Packaging materials and packaging & storage, Technology of Biscuits, Crackers, and Cookies, Woodhead Publishing Limited, (Third edition), pp 211-216,458-460.
- Robertson,G.L., 2010, Food Packaging and Shelf Life, Shelf Life Testing Methodology and Data Analysis, Food Packaging and Shelf Life, Taylor and Francis Group LLCC., pp. 1-17,31-51
- Robertson G, L, 2011, Food Packaging Environment and University of Queensland, Woodhead Publishing Limited, Australia, pp 247-248

# Organoleptic Properties of Curd Prepared by Alternative Starter Cultures used to Replace Existing Starter Culture

J.H.I.G. De Silva<sup>1\*</sup>, A.M.N.L. Abesinghe<sup>2</sup>

<sup>1</sup>Department of Applied and Natural Sciences, University College of Matara, Sri Lanka

<sup>2</sup>Department of Animal Science and Export Agriculture, Uva Wellassa University, Badulla. Sri Lanka

## ABSTRACT

*Curd is formed by using the activity of lactic acid starter cultures. The main objective of this study was to evaluate the organoleptic properties of curd and select an alternative culture for curd without changing the sensory properties. Curd preparation was done in order to standardize the procedure. Types of starter cultures of (A and B) were used. Those were lower in price than the currently in use starter culture. Organoleptic properties of curd prepared with A and B were compared with the curd prepared with currently in use starter culture (C). As the experimental design Completely Randomized Design (CRD) was used. Quantitative data analysis was done using ANOVA for significance under  $\alpha = 0.05$  level using MINITAB 15. Qualitative data analysis was done by Friedman non-parametric test using MINITAB 15. The sensory attributes were evaluated. The shelf life was also determined for the new curd product. Culture type B concluded as the best new alternative culture for curd. There was no significant difference ( $P > 0.05$ ) in organoleptic properties between control and treatment. It was found that the selected alternative new starter culture could reduce the cost of production of curd.*

**Keywords;** Curd, Probiotic, Starter Culture.

## 1. INTRODUCTION

Cultured dairy products (curd, yoghurt) can be specified as the nutritious milk based food products consumed by humans for their several nutritional aspects and production of fermented dairy product can be identified as the best solution for food preservation perspective as well. So many fermented dairy products are in the all over the country and among that Curd can be identified as a type of fermented milk product usually it was made from buffalo milk instead of cow milk due to the higher amount of fat in buffalo milk improves its texture and taste like organoleptic properties in the finished product. (Sri Lanka Standards Institution Standard 1988). Fermented food products can be defined as “any kind of food or beverage which was manufactured through controlled microbial activity and enzymatic activity which is used to conversion of major and minor food components. Curd is a well-known fermented milk product having close equivalence to yoghurt. It has a very good taste, it is in high delicacy. It is can be used not only for refreshing and delicious but nutritious purposes, as well as curds are healthy and easily digestible fermented milk product. Curd is an integral part of the Indian as well as Sri Lankan diet and possesses therapeutic and nutritional properties (Gupta and Prasad, 2000). Curd is also identified as a probiotic or functional fermented milk product as it possesses live lactic acid bacteria. Benefits of consuming curd are; enhanced immune response, balancing of fecal enzymes and intestinal micro flora, prevention of cancer, antibiotic therapy, reduction of serum cholesterol and risk of coronary heart diseases, antagonism against food borne pathogen, tooth decay organism and anti-tumor activity (Pattnaik and Mohapatra, 2000).

The most of research findings suggest that consumption of fermented foods, especially fermented milk products, will give some desirable properties for human health, with including several nutritional benefits and improved health outcomes. Recently, several research findings are revealed that, yogurt and other fermented dairy products that contain live bacteria which can develop dietary aspects for improve human health.

---

\* Corresponding Author: E mail - [imalshagayanidesilva@ymail.com](mailto:imalshagayanidesilva@ymail.com)

Lactic acid bacteria are the major microbes used in manufacturing of curd, yoghurt, and many other dairy fermented dairy products. Among the lactic acid bacteria, *Lactobacillus*, *Streptococcus*, *Lactococcus*, and *Leuconostoc* are most frequently found in fermented dairy products, as starter cultures. However, some fermented dairy products, especially curd, yogurt and other fermented milk products, may also contain added probiotic species of *Bifidobacterium* and *Lactobacillus*. Because probiotics are currently defined “as live microorganisms that, when incorporated in adequate amounts, give more health benefit on the human beings with respect to the nutrition.

Bacterial cultures, known as starters are used in the manufacturing of curd, yoghurt and many other cultured milk products. The starter culture is inoculated to the product and allowed to grow there under desirable conditions. During the process of fermentation, bacterial cultures can produce substances that give the cultured product its characteristic properties such as some physical properties like acidity and the sensory properties like flavour, aroma, and consistency. Decrease in pH, which takes place due to the conversion of lactose to lactic acid by bacterial fermentation, and also it can give the preservative effect on the product, while at the same time the nutritional value and digestibility are improved (Rubiga Sivapatham, 2001). Most of dairy starter cultures are including carefully selected microorganisms, which are purposely inoculated to milk to initiate and carry out fermentation process under controlled conditions to obtain desirable properties. Most of the starter cultures are belonging to lactic acid bacteria (*Lactococcus*, *Lactobacillus*, *Streptococcus* and *Leuconostocs*).The different starter used in the manufacture of curd includes *Lactococcus. lactis*, *L. cremoris*, *Streptococcus thermophilus*, *Lactobacillus bulgaricus*, *L. plantarum* and lactose fermenting yeasts.

The aim of this research project was to find out the best alternative starter culture for curd preparation without compromising the sensory attributes and organoleptic properties of existing curd preparation. As well as to avoid the lack of starter cultures for curd preparation during some periods of the year since we are available many culture types in curd preparation. It will be helpful to provide a continuous supply throughout the year as well.

## 2. METHODOLOGY

The aim or the main objective of this research study was to, Assessment of the organoleptic properties of curd and select a least cost freeze dried culture for curd to use as an alternative starter culture for replace the existing starter culture without compromising the sensory qualities of finished product.

All curd samples were prepared according to the standard procedure given by the Sri Lanka Standard Institution (*SLS part 2:198*). Followed by preliminary development, the production process of curd includes steps of curd mix preparation, preparation of starter cultures, inoculation of starter cultures, incubation of curd cups and finally, transfer to the refrigerator. Selection of the least cost/cost optimized best alternative starter culture for curd preparation was done through the sensory evaluation method. Four replicates were conducted to check the repeatability of sensory results as well as to reduce the experimental errors and compare new products with its physical, chemical and microbial parameters according to current product formulation. Two different multiple species of starter cultures were used (A and B). The curds prepared with new starter cultures were compared with the existing product for its organoleptic characteristics as well as for several physical and microbial parameters. Culture type C (composite of three commercial starter cultures) was the existing culture. Both A and B included *Streptococcus thermophilus*, *Lactobacillus delbrueckii subsp. Bulgaricus* and additionally culture type A included *Bifidobacterium species* and culture type B included *Streptococcus lactis ssp lactis biova diacetylactis*. Whereas C included *Streptococcus thermophiles*, *Bifidobacterium lactis*, *Lactobacillus acidophilus*, *Lactobacillus delberueckii subsp. Bulgaricus*, *Lactobacillus lactis species*. Completely Randomized Design (CRD) comprising three treatments in four replicates were used as the experimental design.

Treatments were; treatment 1 –culture type A, treatment 2 –culture type C (existing curd) and treatment 3 –culture type B. Treatment 2 (existing curd) was used as the control.

Quantitative data analysis was done using ANOVA for significance under  $\alpha=0.05$  level using Minitab 15 statistical software package. Qualitative data analysis was done by Friedman non - parametric test using Minitab 15 statistical software package. In this analysis, 95% confidence interval was considered. The sensory evaluation was carried out with 30 panelists (including seven trained panelists) using nine point hedonic scale to assess sensory qualities of appearance, flavour, texture, mouth feel and overall acceptability. Three sensory evaluations were carried out to compare significant differences between sensory qualities of selected curd and existing curd. Shelf life analysis was done by analyzing titratable acidity, pH like physical parameters and yeasts and moulds, coliforms like microbial quality parameters at five days intervals for 35 days compared with existing curd (control sample). Incubation time was measured in the final product. Cost analysis for starter cultures was done and compared with existing curd production.

### 3. RESULTS AND DISCUSSION

There was no significant difference ( $p>0.05$ ) between sensory properties of appearance, flavour, texture, mouth feel and overall compliance of treatment 1(culture A), 3(Culture B), and the control curd. But Treatment 1, starter culture type A added curd was rejected after four replicates because of setting time is very high compared to Treatment 3(culture type B) and the cost per pack is also very high in treatment 1(Culture type A) compared to the treatment 3. Treatment 3 (culture type B) was selected as the most appropriate alternative starter culture for further analysis. But Culture type A also can be used as a starter culture for curd production even when there is no any alternative. Because sensory properties are equal in all those three types.

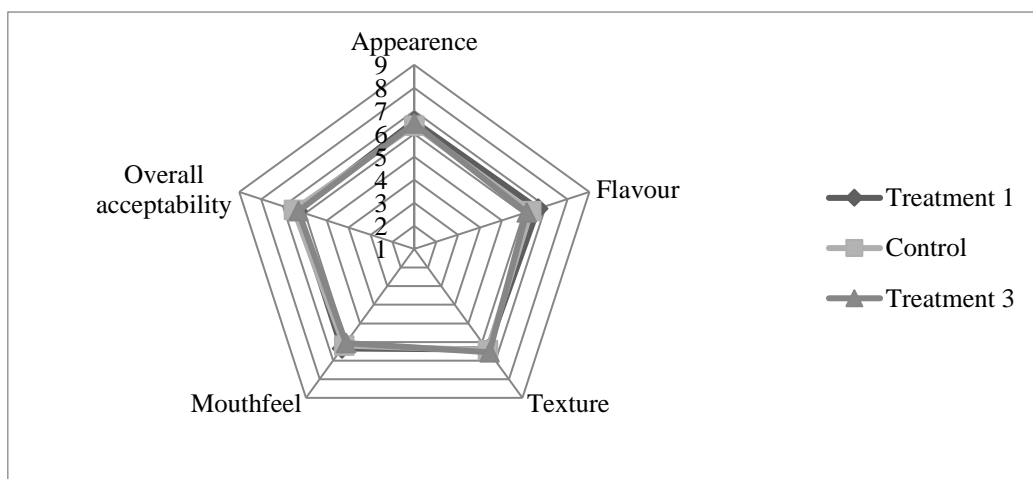

Figure 1: Variation in Sensory Attributes of Curd Prepared with Different Starter Cultures.

Results found that microbial quality (total coliform, yeast and mold counts), Physical properties (pH and titratable acidity) were in conformity to the Sri Lanka Standards limits. Organoleptic properties and incubation time of selected curd were similar to the existing curd. The cost minimized by 6 cents per curd using selected culture and it can be stored at 4 °C up to 35 days.

Treatment 3(was selected as the most suitable alternative starter culture for development of final product after four repeated trials and four sensory evaluations. Because there were no significance difference ( $p>0.05$ ) between sensory qualities of appearance, flavour, texture, mouth feel and overall acceptability like organoleptic properties of finally developed curd and the control curd.

Microbial quality parameters also within the prescribed standards. Coliform were not found in both curds during 35 days of shelf life period it revealed that finished product within the prescribed standards. This may be due to minimum level of contaminations, strictly maintained hygienic practices and addition of food grade preservatives to the curds in the preparation of curd samples. The viability of Coliform bacteria is very low in lactic acid medium. There were zero counts of microbial counts (yeast

and mold), because the addition of preservatives to the curd mix inhibited the microbial growth. It is very important in preparation of cultured dairy products. Similarly, the pasteurization of curd mix helped to inhibit the growth of these microorganisms. There was no significant difference ( $p > 0.05$ ) of pH in curds during the incubation period and the refrigerated storage period. The titratable acidity of the selected curd was within the range of 0.9-1.2% lactic acid (w/w) and it complies with the Sri Lanka Standard Specifications. Therefore, it revealed that, new culture type B has not contributed to the post acidification of curd compared to the control. The cost was optimized by 6 cents per 480 g curd tub due to the usage of new starter culture and It was found that the cost of production of Curd was reduced by Rs. 30,240 per month as an additional outcome of the above research study.

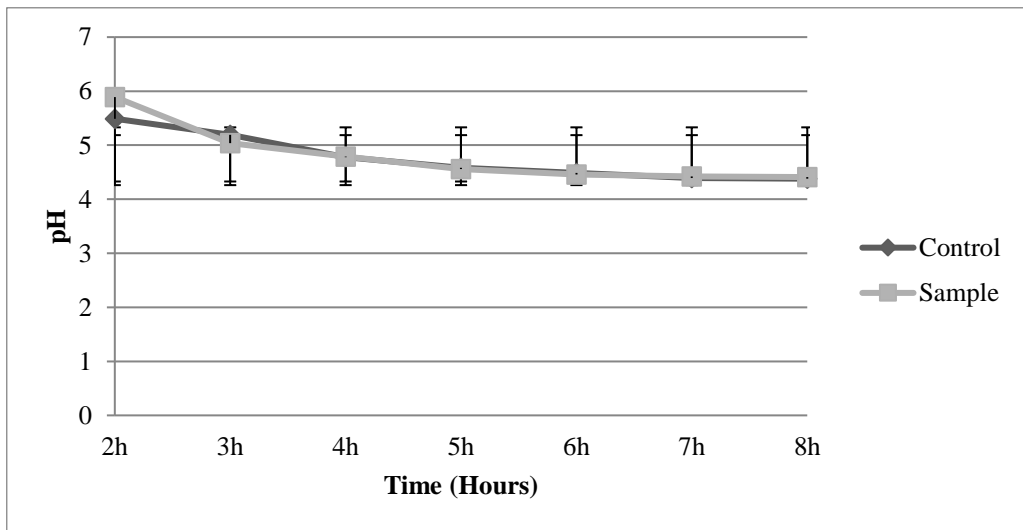

Figure 2: Changes of pH During Incubation of Curd

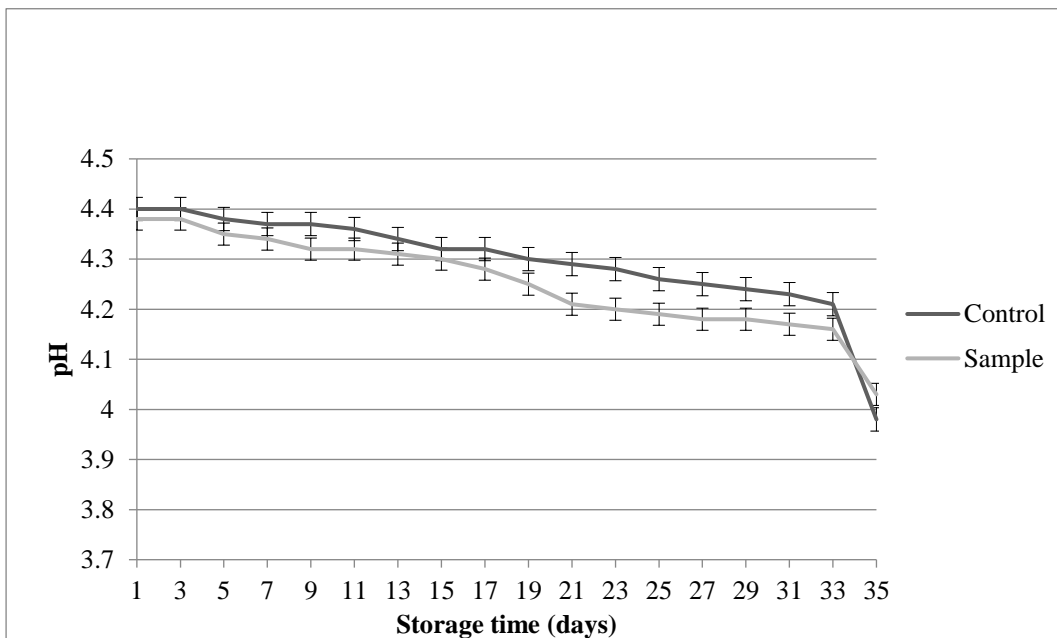

Figure 3: Changes of pH In Curd During Refrigerated Storage

#### 4. CONCLUSION

Results were revealed that there was no difference in the final pH between the curds with the three different starter cultures. Although all two alternative starter culture types are good in curd preparation based on the cost of production, It can be concluded that the starter culture “B” can be used as an

alternative culture to replace the existing composite curd culture without changing organoleptic properties. pH and titratable acidity of the curd prepared with “B” are within the prescribed standards for curd and it showed a shelf life of 35 days at 4 °C under refrigeration conditions. As well as above findings may help to avoid the lack of starter cultures for curd preparation during some periods of the year since we are available many culture types in curd preparation. It will be helpful to assure the continuous product supply throughout the year as well. Consequently, to determine the concentration level of starter cultures, further investigation is needed.

## REFERENCES

- Galpin, S., 2006. Yoghurt culture selection matrix; Fonterra Co-operative Group Limited, M.Sc, Massey University, New Zealand.
- Lampert, C.P. (1970). Definitions of milk, Milk and milk properties, Milton publishers, England. 2-3. National Dairy Research Institute, Dairy Microbiology Division, (September 2006)
- Nelson, A. and Trout, G. 1964. Judging dairy products; The Olsen Publishing Co. Milwaukee, 297-342.
- Pattnaik, P., Mohapatra, D.P., 2000. Are lactic acid bacteria safe enough for human health - a second thought, *Indian Dairyman*, 2000, 52(5), 41-4.
- Sivapatham, R., 2001. Cost optimization in curd. BSc, University of Sri Jayewardenepura, Sri Lanka
- Spreer, E., 1998. Milk and Dairy product technology; Marcel Decker, Inc, 270 Madison Avenue New York; 41- 42, 343.
- Sri Lanka Standards 824: part 2 (1989). Specification for fermented milk products. Sri Lanka Standards Institution, Colombo.

# Textural and Microstructural Properties of Semi - Hard Cheese, Processed Cheese and Milk

Manoj Imbulegama\*

Department of Agriculture and Food Technology, University of Vocational Technology

## ABSTRACT

*Heat treatment, homogenization, adding ingredients, ageing or ripening and storage are essential steps of processing commercial UHT milk, semi-hard cheese and processed cheese. However, these processing steps affect their microstructural and textural properties. This study aimed to determine and compare microstructure and viscosity of raw milk and UHT milk and determine and compare the microstructure, texture and rheology of semi-hard cheese and processed cheese. Different sizes of fat globules and high viscosity were observed in raw milk and almost similar diameters of fat globules and comparatively low viscosity were observed in UHT milk. The homogenization and heat treatment were affected by the fat globules size and viscosity of milk. Maasdam was the mature cheese than the Krievijas and Holandes. The ripening period was affected by the development of air spaces, microstructure and texture of the semi-hard cheese. Farm milk processed cheese and Dzintars processed cheese were almost in the same structure.*

**Keywords:** Microstructure, Natural cheese, Process cheese, Raw milk, Rheology, UHT milk, Viscosity.

## 1. INTRODUCTION

Dairy production and processing have been the predominant economic activities in rural and developed communities in many countries around the world. It is one of the good nutritional quality products that people prefer often. It contains casein as the main protein, lactose as carbohydrate, fat, minerals and many vitamins.

While processing and preparing dairy products, it may change the microstructural, textural, and rheological properties due to heat treatments, homogenization, adding ingredients and storing with a different condition. Previous studies have demonstrated that the differentiation of microstructure and viscosity of cow milk and Soya milk (Grygorczyk et al., 2014), (Lu et al., 2018) have demonstrated the influence of the different proportions of cow milk and goat milk on the chemical, textural and sensory properties.

Some previous studies have illustrated a comparison of textural and microstructural differences of many types of cheese. Li et al. (2013) have described the rheological, textural, microstructural and sensory properties of the spread cheese produced by using soya milk.

In this research, viscosity and microstructures were analyzed among raw milk and UHT milk, and also textural, microstructural and rheological attributes among natural cheese and processed cheese were tested.

## 2. OBJECTIVES

- Determine and compare microstructure and viscosity of raw milk and UHT milk;
- Determine and compare microstructure, texture and rheology of semi-hard cheese and processed cheese.

---

\* Corresponding Author: E-mail - [manojimbulegama@gmail.com](mailto:manojimbulegama@gmail.com)

### 3. MATERIALS AND METHOD

#### 3.1. Materials

Raw milk was obtained from the local dairy farm in Jelgava city Latvia and UHT milk (Farm Milk 3.2% fat) was obtained from the supermarket in Jelgava. Three types of semi-hard cheese (Holandes, Krievijas, and Maasdam) and two types of processed cheese (Farm milk and Dzintars) were also obtained from the supermarket in Jelgava.

#### 3.2. Method

##### 3.2.1 Evaluation of Microstructure of Milk and Cheese

The sample were prepared by using drops from milk and process cheese and 1mm to 2mm tiny and very small particles from semi-hard cheese to the slides separately as and closed by using another slide then checked. The light microscope (LEI CA DM 3000 LED, Camera LEICA DFCHD 290) was used for the testing of the microstructure of the samples (El-Bakry & Sheehan, 2014). The diameter of the fat globules of raw milk and UHT milk was determined with the help of the LAS V4.2-Microstruc programme.

##### 3.2.2. Evaluation of Milk Viscosity

Programmable rheometer DV-III Ultra (Brookfield Engineering Laboratories Inc., USA) was used for the testing of the viscosity of raw milk and UHT milk. The SC4-18 spindle and the shear stress was measured as a function of the applied shear rate by determining the viscous drag on the rotating body immersed in each of the raw milk and UHT milk separately. The sample was taken in the outer cylinder as half of the fill separately. The shear rate was increased between 30 and 300 s<sup>-1</sup>. Each of these viscosity measurements was processed using Rheocal V2.6 software at room temperature around 23 -25 °C.

##### 3.2.3. Evaluation of Semi-Hard Cheese Texture

For the testing of texture, samples were prepared with ten 1×1 cm cylinders from each type of semi-hard cheese. Texture analyser TA.HD.Plus (Stable Microsystem, UK) was used for the testing of the texture of three types of semi-hard cheeses as a compression test at room temperature (25±1 °C). For the compression test, a cheese sample was compressed twice using a cylinder with a diameter of 25 mm at a distance of 5 mm, with a speed of 1 mm s<sup>-1</sup>.

Each test was repeated 10 times separately and hardness was determined using the Texture exponent-32 software.

##### 3.2.4. Evaluation of Processed Cheese Rheology

The viscoelastic properties of the two types of processed cheeses were analyzed separately using a Modular compact Rheometer MRC- 302 (Anton Paar, Austria) with the plate to plate geometry (diameter 25 mm, gap 1 mm) at a temperature of 20.0 ± 0.1 °C. All the samples were measured in the controlled shear stress mode at a frequency ranging from 0.01 to 100.00 Hz. The selected monitored parameters determined as a function of frequency included the storage modulus (G') and loss modulus (G'') by using Frequency sweep.

### 4. RESULTS AND DISCUSSION

The fat globules of both raw milk and UHT milk showed spherical shape (Fig. 1). The size and the diameter of the fat globules were different in raw milk compared to the UHT milk. The size and the diameter of fat globules were almost the same in sizes of UHT milk. Because the raw milk was neither heat-treated nor homogenized. Therefore the fat globules were in different sizes. But for the UHT milk is normally subjected to the high-temperature heat treatment and homogenized under 65 – 70 °C and high-temperature homogenization causes clustering and break up fat globules and finally reduced the



viscosity. Therefore the fat globules showed the same sizes as a homogeneous commercial product. The average diameter of fat globules in raw milk was  $2.11 \pm 0.7 \mu\text{m}$  and the UHT milk was  $1.35 \pm 0.04 \mu\text{m}$  (Table 1). There was a significant difference in the diameter of fat globules in raw milk and UHT milk. The average viscosity of the raw milk was  $2.54 \pm 0.01 \text{ m Pas}$  and the UHT was  $2.41 \pm 0.01 \text{ m Pas}$  (Table 2). Raw milk has the largest fat globules and more different sizes and because viscosity is less compared with UHT milk.

Table 1: Average Diameter of Fat Globules

Group	Count	Sum	Average Diameter ( $\mu\text{m}$ )	Variance
Raw Milk	20	42.1184	2.11	0.70
UHT Milk	20	27.0934	1.35	0.043

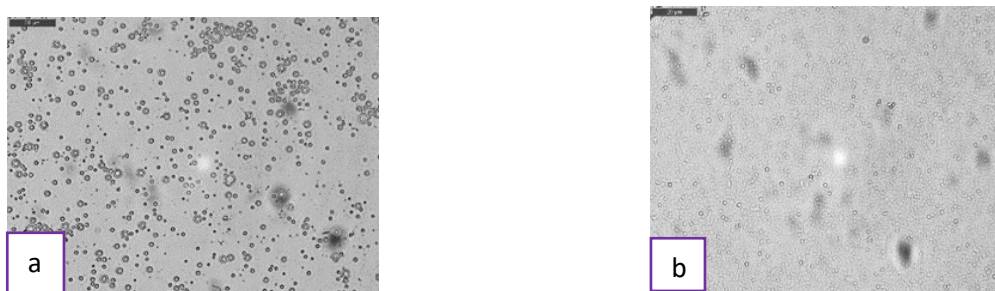

Figure 1: Microstructure of milk: a – Raw milk, b – UHT milk

Table 2: Average Viscosity of Raw milk and UHT milk

Group	Count	Sum	Average Viscosity (m Pas)	Variance
Raw Milk	20	42.1184	2.11	0.70
UHT Milk	20	27.0934	1.35	0.043

The microstructure of Maasdam, Krievijas and Holandes natural cheeses showed almost similar structure with different particles in different sizes and some air spaces as shown in Fig. 3, Fig. 4 and Fig. 5 respectively. The particles may be fat, protein salt and emulsifiers. The Maasdam cheese was silicated larger air spaces than the others and Krievijas cheese had smaller air spaces than the others. Holandes cheese elicited a more homogeneous cheese structure compared with Maasdam and Krievijas. The reasons may be due to the kind of microbe’s activities during the ripening process and the type of microbes used for the fermentation of natural cheese. The storing period also may be affected for the creation of air spaces.

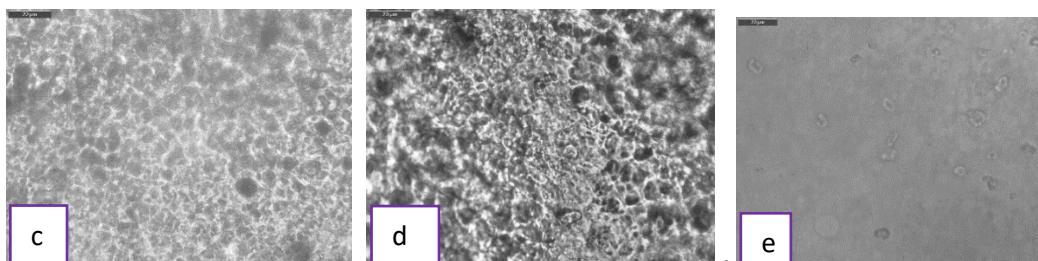

Figure 2: Microstructure of semi-hard cheese: c – Maasdam; d – Krievijas; e – Holandes

The Maasdam, Krievijas and Holandes natural cheeses showed an average hardness of  $99.8 \pm 0.3$  n,  $54.8 \pm 0.2$  n and  $20 \pm 0.5$  n respectively (Table 3). The graph (Fig 3) was shown the TPA- texture profile analysis of one measurement of the sample with two comparisons.

Table 3: Average Hardness of Semi-Hard Cheese

Parameter	Maasdam	Krievijas	Holandes
Average hardness (N)	99.83194	54.78727	20.01963
S.D.	34.55537	11.36236	9.29866
Coef.of Variation	0.34614	0.20739	0.46448

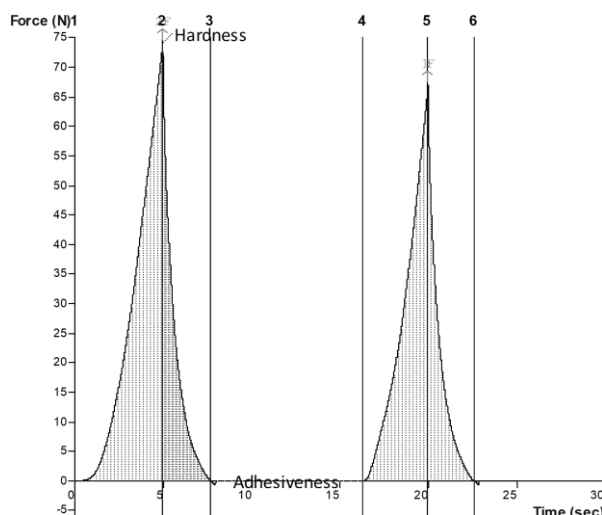

Figure 3: TPA- texture profile of Semi-hard cheese

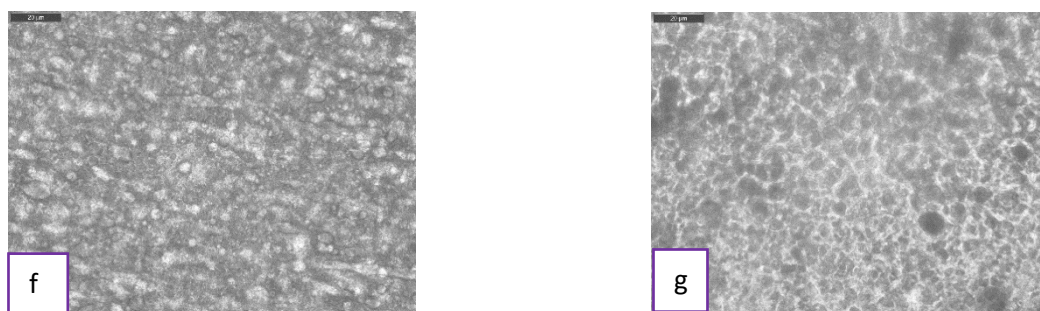

Figure 4: Microstructure of process cheese: f– Farm milk cheese, g – Dzintars cheese

Farm milk processed cheese and Dzintars processed cheese showed almost similar microstructure (Fig 3). The graph (Fig 5) was showed the viscoelasticity behavior of process cheeses and the  $G'$  and  $G''$  were maximum in Dzintars cheese which was more viscoelastic compared to the farm milk cheese. The  $G'$  of both kinds of cheeses were less than the  $G''$  up to some extend of frequency. Then  $G''$  showed a step increase. The protein network structure is responsible for making cheese viscoelastic. When fresh, the proteins of the cheese tend to maintain strong protein-to-protein interactions and have high  $G'$  values even though expressible water and fat are present within the fat channels. High protein and ash (particularly calcium) and low-fat contents in these cheeses are attributed to high values of  $G'$  and  $G''$ . The values of elastic modulus ( $G'$ ) were higher than viscous modulus ( $G''$ ) in all the cheeses. The higher

values of elastic modulus as compared to their respective viscous modulus indicate that both kinds of cheeses behaved more like an elastic material.

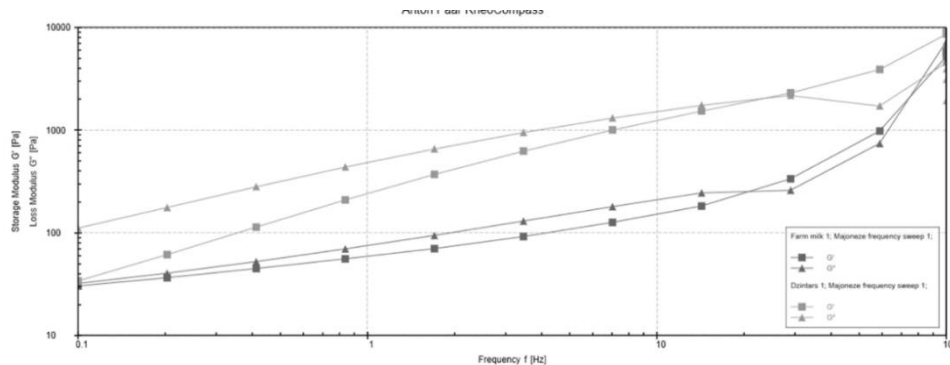

Figure 5: Viscoelasticity of process cheese

## 5. CONCLUSION

There is a significant difference in diameter of the fat globules of raw milk and UHT milk and it was influenced by the viscosity of milk. Maasdam was the hardest and matured semi-hard cheese than the Krievijas and Holandas. The Holandas cheese was softer and immature cheese than Maasdam and Krievijas. Farm milk processed cheese and Dzintars processed cheese was displaying almost similar microstructure and Dzintars was high viscoelastic than in the Farm milk cheese.

## REFERENCES

- El-Bakry, M., & Sheehan, J. (2014). Analysing cheese microstructure: A review of redevelopments. *Journal of Food Engineering*, 125, 84–96.
- Grygorczyk, A., Duizer, L., Lesschaeve, I. and Corredig, M., (2014). Gelation of recombined soymilk and cow's milk gels: Effect of homogenization order and mode of gelation on microstructure and texture of the final matrix. *Food Hydrocolloids*, 35, pp.69-77.
- Joshi, N.S., Jhala, R.P., Muthukumarappan, K., Acharya, M.R. and Mistry, V.V., (2004). Textural and rheological properties of processed cheese. *International Journal of Food Properties*, 7(3), pp.519-530.
- Li, Q., Xia, Y., Zhou, L. and Xie, J., (2013). Evaluation of the rheological, textural, microstructural and sensory properties of soy cheese spreads. *Food and bioproducts processing*, 91(4), pp.429-439.
- Lu, J., Pickova, J., Vázquez-Gutiérrez, J.L. and Langton, M., 2018. Influence of seasonal variation and ultra high temperature processing on lipid profile and fat globule structure of Swedish cow milk. *Food chemistry*, 239, pp.848-857.

# The Potential Contribution of Soy Isoflavones in the Health of Menopausal Women, Revealing the Avenues for Soy Food Manufacturing Industry

J.M.C.M. Jayasekara\*<sup>1</sup>, S.M.C.S. Samarakoon<sup>2</sup>

<sup>1</sup>Division of Applied and Natural Sciences, University College of Matara, Sri Lanka

<sup>2</sup>Centre for Applied Science and Primary Industries, Waikato Institute of Technology, New Zealand

## ABSTRACT

*Most of the women above the age of 45 years are experiencing the consequences of natural menopause. Menopausal women simultaneously face the challenge of menopausal symptoms plus the risk associated with non-communicable diseases. Cardiovascular diseases and osteoporosis are abundant. Natural remedies are sought widely for this condition rejecting hormone replacement therapy blaming the risks associated. The intake of soybean isoflavones is the best choice as the natural treatment strategy for both symptom relief and disease prevention. This review focused on general information about soy isoflavones, their impact on menopausal health, isoflavone contents in different soy food, and their manufacturing suggestions. Founded in the literature evidence, soy food and isoflavones are satisfactorily effective and secure for menopausal health.*

**Keywords:** *Isoflavones, Menopause, Soybeans, Soy Foods.*

## 1. INTRODUCTION

Menopause is a woman's life stage that permanently stops having menstrual periods. It is the end of a woman's ability to have children. Menstrual periods need to have been ceased for one continuous year to confirm the menopause. Natural menopause happens at the average age of about 51 years (Greendale, Lee, and Arriola, 1999).

The transition phase before menopause is referred to as the perimenopause period, usually begins around age 45, which may exist between 2-8 years (Greendale, Lee, and Arriola, 1999). During the perimenopause period, the mature eggs supply and ovulation become irregular. Simultaneously, the production of estrogen and progesterone hormones decreases. Women face both physical and psychological alterations during menopause. Some women develop depressive symptoms as well (Erbil, 2018). The symptoms associated with menopause are the cause of hormone levels changes such as reduction in estrogen, thyroid, parathyroid, and prolactin hormone levels and increases in some gonadotrophic hormones for instance, follicle-stimulating hormone (FSH) and luteinizing hormone (LH) levels (Erbil, 2018).

Perimenopause symptoms start with irregular menstrual periods which may account for shortened or extended menstrual cycles, amenorrhea and hot flashes/hot flushes. The availability of sex hormones depends on the adrenal glands and adipose tissue during this period (Ojeda, 1992). Menopausal symptoms consist of hot flashes which women feel as night sweats (in 80% of women), vaginal lubrication reduction, thinning of vaginal mucosa, vaginal atrophy, vaginal irritation, painful intercourse, mood swings, difficulty concentrating, impairment of short-term memory, insomnia, depression, urinary problems and incontinence, skeletal problems, cardiovascular diseases, breast atrophy and skin atrophy (Manson and Kaunitz, 2016; Gümüşay and Erbil, 2016).

The hormone levels changes, especially the decline in estrogen hormone directs to several non-communicable diseases. The risk is considerably high due to genetics, poor dietary habits and lifestyle

---

\* Corresponding Author: E-mail - [Chajayase@gmail.com](mailto:Chajayase@gmail.com)

practices. According to Marjoribanks *et al.*, (2012), postmenopausal women are vulnerable to the most prevalent non-communicable diseases for instance osteoporosis and heart disease.

As described by Verhaeghe *et al.* (1996), the deficiency in ovarian hormones speeds up bone loss by increasing the bone turnover rate. It causes imbalanced resorption and formation while it alters the healthy metabolic profile. The risk of type-II diabetes mellitus is also increased (Slopien *et al.*, 2018). Postmenopausal women have a higher concentration of testosterone hormone in the absence of adequate estrogen levels. Higher concentration of testosterone levels tend to increase low density lipoprotein (LDL) levels and decrease high density lipoprotein HDL levels. This is done by increasing hepatic lipase activity resulting in poor cardiovascular health (Seed, 1991).

The common treatment for menopausal symptoms is the hormone replacement therapy (HRT) (Hill, Crider, and Hill, 2016). Nowadays women are turning to natural approaches to relieve menopausal discomforts as the majority are reluctant to get HRT complaining about the risk of breast cancers and other side effects (De Franciscis *et al.*, 2019). This growing interest in natural solutions for treating menopausal symptoms has encouraged the food and supplement industries to develop alternatives to conventional pharmaceutical estrogen such as Premarin.

Soybeans were naturally high in phytoestrogen content (He and Chen, 2013). This could be an opportunity for the soy food industry to create new market avenues and obtain benefits by focusing on processing strategies and creating new food products and nutraceuticals for menopausal women. This review declares the potential contributions of isoflavones available in soybeans on menopausal health suggesting avenues for the soy food manufacturing industry.

## **2. SOY FOODS AND ISOFLAVONES**

### **2.1. Soybean**

The Soybean plant [*Glycine max* (L. Merrill)] is a leguminous plant. The soybean plant is a straight plant of about 0.7 to 1.4 m in height. It consists of large trifoliolate leaves, flowers, and pods. Pods contain one to four seeds. The soybeans are spherical in shape and are light yellow coloured. Some varieties hold green, brown, or black coloured seeds (Perkins, 1995).

Soybeans contain about 37.9% protein, 17.8% fat, 35% carbohydrates, isoflavones, and a lot of minerals and vitamins. Soybean protein can be considered as a complete protein since it contains all eight essential amino acids in the soybean (Perkins, 1995). The isoflavone content in soybeans is 1.2–4.2 mg/g dry weight. Different isoflavone contents vary with the genotype, growing location, like factors (Lundh, 1995).

### **2.2. Soy Isoflavones**

Isoflavones are a phytoestrogen category. They have phenolic structures that are the same as estrogen 17 $\beta$ -estradiol. Isoflavones can bind estrogen receptors due to the phenolic structures (Sakai and Kogiso, 2008). Isoflavone is a heat-stable factor, and it exists in the plant as glycosides (Perkins, 1995). Genistein, daidzein, and glycitein are isoflavone types found in soybeans. The contents of these isoflavones vary in different components of the soybean. The whole soybean contains approximately similar amounts of genistein and daidzein. Table 1 shows the isoflavone content of soybeans and soy-based products.

Researchers have figured out menopausal symptom relief and disease prevention ability of soy isoflavones. It has been revealed that supplements that contain soy isoflavone increase bone mineral density considerably thereby lower the risk of osteoporosis in menopausal women (Wei *et al.*, 2012). Chalvon-Demersay *et al.* (2017) has concluded that soy isoflavones may prevent the commencement of hypercholesterolemia and hypertension which may increase the risk of cardiovascular disease. The consumption of soy isoflavone in the form of supplements has been identified as a better option for controlling body weight, insulin, and glucose levels (Zhang *et al.*, 2013). Nagata *et al.* (2014) identified the capability of decreasing the breast cancer risk among Japanese women when soy foods are being

consumed. Wei *et al.* (2012) reported that the Japan Food Safety Commission has recognized an intake of isoflavone daily up to 75 mg as safe.

Table 1: Isoflavone Content of Some Soy-Based Foods.

<b>Food</b>	<b>Mean isoflavones content (mg/100g)</b>	<b>Daidzein (mg/100g)</b>	<b>Genistein (mg/100g)</b>
<b>Soybeans</b>	128.83	61.70	60.07
<b>Soy flour, full-fat</b>	178.10	72.92	98.77
<b>Soy flour, textured</b>	172.55	67.69	89.42
<b>Soy protein isolate</b>	91.05	30.81	57.28
<b>Soy protein concentrate, aqueous washed</b>	102.07	43.04	55.59
<b>Natto</b>	58.93	21.85	29.04
<b>Tempeh</b>	60.61	22.66	36.15
<b>Miso</b>	42.55	16.13	24.56
<b>Soybean sprouts</b>	40.71	19.12	21.60
<b>Tofu (soft)</b>	29.24	8.59	20.65
<b>Soy Lecithin</b>	15.70	5.40	10.30
<b>Tofu yoghurt</b>	16.30	5.70	9.40

Source: USDA database, U.S. Department of Agriculture, Agricultural Research Service (2015).

Isoflavones extraction is an important step for soy nutraceutical manufacturing. Isoflavones can be extracted from soybeans by some conventional methods, for instance, maceration, percolation, and Soxhlet extraction for the purpose of chemical analysis. Novel extraction methods such as supercritical fluid extraction, ultrasound-assisted extraction, accelerated solvent extraction, microwave-assisted extraction, and negative pressure cavitation extraction can be introduced as more efficient methods for extracting isoflavone (Blicharski and Oniszczuk, 2017). A novel eco-friendly procedure has been revealed recently to extract isoflavone from soybean seed flour with the use of water as the solvent (Lante *et al.*, 2018).

### 3. THE ACTION OF ISOFLAVONES

The action of soy isoflavones spreads in four diverse ways since isoflavones act like estrogen and anti-estrogen (Křížová *et al.*, 2019; Horn-Ross *et al.*, 2003), cancer-enzyme inhibitors (Barnes, Peterson, and Coward, 1995; Fotsis *et al.*, 1995), antioxidants (Ruiz-Larrea *et al.*, 1997; Cai and Wei, 1996), and immune enhancers (Wang, Higuchi and Zhang, 1997).

#### 3.1. Estrogens and Anti-Estrogens

Isoflavones are considered non-steroidal estrogen as the chemical structure is prominently similar to the estrogen hormones produced in women. In the absence or lack of true estrogen, isoflavones tend to have an estrogen similar effect. It is manifested by taking the dietary supplements that contain isoflavones which leads to reduce the occurrence of hot flashes from 10 to 20 per cent (Křížová *et al.*, 2019).

The isoflavones act as anti-estrogen as well. Horn-Ross *et al.* (2003) suggested the high isoflavone quantity might be prophylactic over endometrial carcinoma due to anti-estrogenic activity.

#### 3.2. Cancer-Enzyme Inhibitors

Tyrosine kinase is an enzyme which involves in cancer cell growth. Isoflavones have the ability to reduce cancer risk by the mean of inhibiting the activity of the tyrosine kinase enzyme (Barnes, Peterson, and Coward, 1995). It is the primary anticancer mechanism of isoflavones. However, genistein has been identified as an anti-angiogenic substance, that blocks the growth of blood vessels required for tumour expansion (Fotsis *et al.*, 1995).

### 3.3. Antioxidants

Isoflavones are also powerful antioxidants. Antioxidants can prevent the damages caused by free radicals thus protecting deoxyribonucleic acid (DNA). Genistein is the most effective antioxidant while daidzein is the second most effective one (Ruiz-Larrea *et al.*, 1997). According to the explanation of Cai and Wei (1996), genistein holds the ability to increase superoxide dismutase (SOD) production. Superoxide radicals in the human body can be quenched by SOD as it is potent antioxidant.

### 3.4. Immune Enhancers

Daidzein has the capability to activate immune cells which helps to reduce the cancer risk. Wang, Higuchi, and Zhang (1997) found that daidzein involves in the increase of lymphocytes (T cells) activity and macrophages (a type of white blood cell) activity during a study conducted with laboratory mice.

## 4. SOY FOODS

A difference has been observed by Medic, Atkinson, and Hurburgh (2014) in food products processed using soybeans in Asian and Western cultures. Traditional soy-based foods, such as soymilk, tempeh, miso, tofu, natto and soy sauce are widely produced in Asian countries while soybean meal and seed oil are the common products processed in Western countries. The most popular soy food products are tofu and soymilk (Islas-Rubio and Higuera-Ciapara, 2002).

## 5. INDUSTRIAL AVENUES FOR SOY FOOD PROCESSING

The primary product of soybeans is soy meal. Soybean oil and lecithin are secondary products. Solvent extraction is the commonly used method for the extraction of soybean oil. Soy meal which contains high protein content (50%), is generally used as animal feed. A segment of soy meal is further processed into soy protein ingredients such as soy flour, soy protein concentrates, soy protein isolates, and textured soy proteins. These soy protein ingredients are used in the production of bakery products, dairy and meat products, infant formulas, etc. Fat removed soy flakes which are collected after solvent extraction are utilized to produce soy flour, soy grits, and textured vegetable protein (TVP) by grinding, sizing and texturizing techniques respectively. Soy protein concentrates and isolated soy proteins are also can be processed using defatted flakes. Lecithin (an essential emulsifier) is produced by degumming the crude oil, followed by drying and cooling (Islas-Rubio and Higuera-Ciapara, 2002).

There are two main categories of soy foods as fermented and non-fermented. Tempeh, soy yoghurt (fermented soymilk), miso (fermented soy paste), sufu (fermented tofu), soy sauce, soy nuggets (fermented whole soybeans) and natto are some fermented soy food varieties. Fresh soybeans, whole dry soybeans, soy nuts, soy sprouts, whole fat soy flour, soymilk, tofu, okara (soy pulp), yuba (soymilk film) are non-fermented products (Golbitz, 1995; Liu, 2008).

Different processing techniques and technologies have been utilized over the past decades in extracting compounds from soybeans and soy food processing. Replacing the conventional pasteurization, a novel food processing approach of high-pressure processing is there for soymilk processing for achieving safety (inactivation of microbes and anti-nutritional factors) while retaining the nutritive quality. A pressure of 600 MPa is applied in this technique (Smith, 2009). During the production of soy protein isolates (which is a common functional ingredient used in meat processing) gas-supported screw pressing (GSSP) has been identified as an environmentally friendly way to produce soybean meal. The heat denaturation is quite little in this method (Smith, 2009). The use of ultra-high-pressure homogenization or ultra-high-temperature processing has been identified as effective means of stabilizing particles in soymilk (Liu, 2008).

Elimination of beany flavour is important when processing soy foods. Beany flavour formation prevention by enzyme inactivation, removing the volatile compounds (ketones, aldehydes, and alcohols) those responsible for the beany flavour, masking the residual beany flavour by artificial flavours are some solutions (Liu, 2008).

During soy food processing, combining soy isoflavones with lactic acid bacteria such as *L. acidophilus*, *S. thermophilus*, *L. cellobiosus*, *L. plantarum*, and *L. Lactis* in the form of spores is suggested to guarantee the bioavailability of soy isoflavones. The assurance is given because the absorption of the soy isoflavones depends on the existence of the intestinal microflora that can produce glycosidases. The hydrolysis of genistein and daidzin to aglycons (the active form) is facilitated by glycosidases (De Franciscis *et al.*, 2019), consequently, the bioavailability is ensured.

## 6. CONCLUSION

Soy-based isoflavones effectively control menopausal symptoms and involve in preventing diseases among menopausal women. Therefore, it can be considered as the best natural remedy for those who refuse to take HRT. A daily intake of up to 75 mg total isoflavones is recommended as safe. Supplements or foods providing significant content of genistein have performed better compared to other soy isoflavones. The soy food processing industry should be updated with novel technological aspects to improve the isoflavone content and to enhance the isoflavones bioavailability in soy-based processed products.

## REFERENCES

- Barnes, S., Peterson, T., Coward, L., 1995. The Rationale for the use of Genistein Containing Soy Matrices in Chemoprevention Trials for Breast and Prostate Cancer. *Journal of Cellular Biochemistry*, 22, pp. 181-187.
- Blicharski, T. and Oniszczyk, A., 2017. Extraction Methods for the Isolation of Isoflavonoids from Plant Material. *Open Chemistry*, 15(1).
- Cai, Q. and Wei, H., 1996. Effect of Dietary Genistein on Antioxidant Enzyme Activities in SENCAR Mice. *Nutrition and Cancer*, 25(1), pp.1-7.
- Chalvon-Demersay, T., Azzout-Marniche, D., Arfsten, J., Egli, L., Gaudichon, C., Karagounis, L.G. and Tomé, D., 2017. A Systematic Review of the Effects of Plant Compared with Animal Protein Sources on Features of Metabolic Syndrome. *The Journal of Nutrition*, 147, pp. 281-292.
- De Franciscis, P., Colacurci, N., Riemma, G., Conte, A., Pittana, E., Guida, M., Schiattarella, A., 2019. A Nutraceutical Approach to Menopausal Complaints. *Medicina*, 55(9), p.544.
- Erbil, N., 2018. Attitudes towards Menopause and Depression, Body Image of Women during Menopause. *Alexandria Journal of Medicine*, 54(3), pp.241-246.
- Fotsis, T., Pepper, M., Adlercreutz, H., Hase, T., Montesano, R., Schweigerer, L., 1995. Genistein, a Dietary Ingested Isoflavonoid, Inhibits Cell Proliferation and in Vitro Angiogenesis. *Journal of Nutrition*, 125, pp.790-797.
- Golbitz, P., 1995. Traditional Soyfoods: Processing and Products. *The Journal of Nutrition*, 125(3), pp.570-572.
- Greendale, G.A., Lee, N.P. and Arriola, E.R., 1999. The Menopause. *The Lancet*, 353(9152), pp.571-580.
- Gümüşay, M. and Erbil, N., 2016. Alternative Methods in the Management of Menopausal Symptoms. *Middle Black Sea Journal of Health Science*, 2(2), p.20.
- He, J. and Chen, Q., 2013. Consumption of Soybean, Soy Foods, Soy Isoflavones and Breast Cancer Incidence: Differences between Chinese Women and Women in Western Countries and Possible Mechanisms. *Food Science and Human Wellness*, 2(3-4), pp.146-161.
- Hill, A., Crider, M., Hill, R., 2016. Hormone Therapy and Other Treatments for Symptoms of Menopause. *American Family Physician*, 94, pp.884-889.
- Horn-Ross, P., John, E., Canchola, A., Stewart, S., Lee, M., 2003. Phytoestrogen Intake and Endometrial Cancer Risk. *JNCI Journal of the National Cancer Institute*, 95(15), pp.1158-1164.
- Islas-Rubio, A. and Higuera-Ciapara, I., 2002. *SOYBEANS: Post-harvest Operations*. Food and Agriculture Organization of the United Nations (FAO).



- Křížová, L., Dadáková, K., Kašparovská, J. and Kašparovský, T., 2019. Isoflavones. *Molecules*, 24(6), p.1076.
- Lante, A., Barion, G., Zannoni, S., Pastore, M.R., Tinello, F., Dal Cortivo, C., Vameralli, T. and Mosca, G., 2018. An ecofriendly procedure to extract isoflavones from soybean seeds. *Journal of Cleaner Production*, 170, pp.1102–1110.
- Liu, K., 2008. Food Use of Whole Soybeans. *Soybeans*, pp.441-481.
- Lundh, T., 1995. Metabolism of Estrogenic Isoflavones in Domestic Animals. *Experimental Biology and Medicine*, 208(1), pp.33–39.
- Manson, J. and Kaunitz, A., 2016. Menopause Management - Getting Clinical Care Back on Track. *New England Journal of Medicine*, 374(9), pp.803–806.
- Marjoribanks, J., Farquhar, C., Roberts, H. and Lethaby, A., 2012. Long Term Hormone Therapy for Perimenopausal and Postmenopausal Women. *Cochrane Database of Systematic Reviews*.
- Medic, J., Atkinson, C. and Hurburgh, C., 2014. Current Knowledge in Soybean Composition. *Journal of the American Oil Chemists' Society*, 91(3), pp.363–384.
- Nagata, C., Mizoue, T., Tanaka, K., Tsuji, I., Tamakoshi, A., Matsuo, K., Wakai, K., Inoue, M., Tsugane, S., Sasazuki, S., Sasazuki, S., Tsugane, S., Inoue, M., Iwasaki, M., Otani, T., Sawada, N., Shimazu, T., Yamaji, T., Tsuji, I. and Tsubono, Y., 2014. Soy Intake and Breast Cancer Risk: An Evaluation Based on a Systematic Review of Epidemiologic Evidence among the Japanese Population. *Japanese Journal of Clinical Oncology*, 44(3), pp.282–295.
- Ojeda, L., 1992. *Menopause without medicine: feel healthy, look younger, live longer*. Almeda:Hunter House.
- Perkins, G., 1995. Composition of Soybeans and Soybean Products. *Practical Handbook of Soybean Processing and Utilization*, pp.9-28.
- Ruiz-Larrea, M., Mohan, A., Paganga, G., Miller, N., Bolwell, G., Rice-Evans, C., 1997. Antioxidant Activity of Phytoestrogenic Isoflavones. *Free Radical Research*, 26(1), pp.63–70.
- Sakai, T. and Kogiso, M., 2008. Soy Isoflavones and Immunity. *The Journal of Medical Investigation*, 55(3-4), pp.167–173.
- See, M., 1991. Sex Hormones, Lipoproteins, and Cardiovascular Risk. *Atherosclerosis*, 90, pp.1-7.
- Slopien, R., Wender-Ozegowska, E., Rogowicz-Frontczak, A., Meczekalski, B., Zozulinska-Ziolkiewicz, D., Jaremek, J.D., Cano, A., Chedraui, P., Goulis, D.G., Lopes, P., Mishra, G., Mueck, A., Rees, M., Senturk, L.M., Simoncini, T., Stevenson, J.C., Stute, P., Tuomikoski, P., Paschou, S.A. and Anagnostis, P., 2018. Menopause and diabetes: EMAS clinical guide. *Maturitas*, 117, pp.6–10.
- Smith, K., 2009. *Novel Technologies for Soy Products, Processing, and Applications*. Graduate Theses and Dissertations. 10785.
- U.S. Department of Agriculture, Agricultural Research Service. 2015. USDA Database for the Isoflavone Content of Selected Foods, Release 2.1. Nutrient Data Laboratory Home Page: <http://www.ars.usda.gov/nutrientdata/isoflav>.
- Verhaeghe, J., VanBree, R., VanHerck, E., Thomas, H., Skottner, A., Dequeker, J., 1996. Effects of Recombinant Human Growth Hormone and Insulin-like Growth factor-I, with and without 17-estradiol, on Bone and Mineral Homeostasis of Aged Ovariectomized Rats. *Journal of Bone and Mineral Research*, 11, pp.1723-1735.
- Wang, W., Higuchi, M., Zhang, R., 1997. Individual and Combinatory Effects of Soy Isoflavones on the In-Vitro Potentiation of Lymphocyte Activation. *Nutrition and Cancer*, 29(1), pp.29–34.
- Wei, P., Liu, M., Chen, Y., Chen, C., 2012. Systematic Review of Soy Isoflavone Supplements on Osteoporosis in Women. *Asian Pacific Journal of Tropical Medicine*, 5(3), pp.243–248.
- Zhang, B., Chen, H., Guo, J., Fu, H., Yi, C., Zhang, M., Na, L., 2013. Soy Isoflavone Supplementation Could Reduce Body Weight and Improve Glucose Metabolism in Non-Asian Postmenopausal Women—a Meta-Analysis. *Nutrition*, 29(1), pp.8-14.

# Usage of Domestic Refrigerators for Safe Food Storage among Sri Lankan Families

J.M.C.M. Jayasekara\*

Division of Applied and Natural Sciences, University College of Matara, Sri Lanka

## ABSTRACT

Practices related to domestic refrigerator handling have a significant impact on the quality and safety of refrigerated food. The purpose of this study was to determine the Sri Lankans' knowledge and practices related to the storage of food in refrigerators and to identify measures to reduce food deterioration, food-borne diseases, and food wastage. A cross-sectional study was conducted from June to August 2021. A questionnaire was filled in by 342 respondents from 6 provinces in Sri Lanka facilitating to obtain information related to the characteristics of family, refrigerator, and handling practices. Malpractices such as refrigerator door opening more than 10 times per day (59.7% of the respondents\*), inadequate cleaning of foodstuff (fruits and vegetables: 42%\* and eggs: 58.2%\*) and interior of the refrigerator (90%\*) were identified. There was a significant association ( $p < 0.05$ ) between the level of education and the refrigerator handling knowledge and practices. The importance of promoting proper awareness was identified to overcome the knowledge gap among Sri Lankans.

**Keywords:** Domestic Refrigerator, Food Quality, Food Safety and Knowledge.

## 1. INTRODUCTION

The domestic refrigerator is becoming a common appliance use in most Sri Lankan houses for storing foods. It is manifested by the annual increment of the sales volume of domestic refrigerators in Sri Lanka. The sales volume of domestic refrigerators has been increased drastically during the past two decades as Statista Research Department, published in February, 2021.

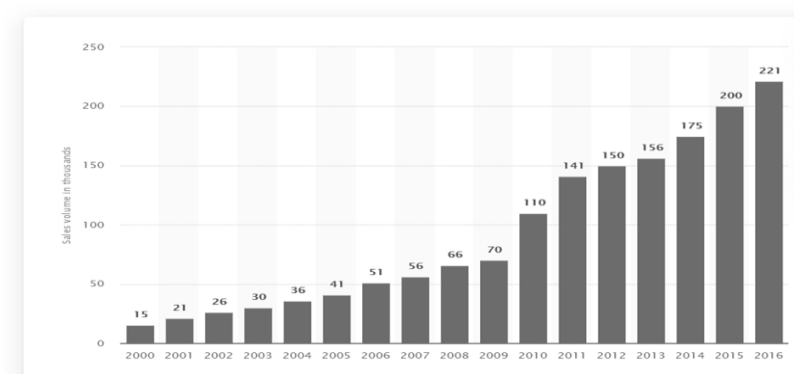

Figure 1: Sales Volume of Refrigerators in Sri Lanka from 2000 to 2016

Refrigeration and freezing have become popular as they help to store and to preserve foods under a lower temperature which retard the metabolic activities of microorganisms and retarding the rate of physico-chemical changes that happen in fresh food cells. The domestic refrigerators are important for storing different types of foods together that require various storage conditions in order to maintain the quality throughout the short period of time in which the food stuff is stored (Mascheroni and Salvadori, 2011). Constant running of refrigerators in proper conditions has been identified as an important factor to keep the foods safe if not it will cause serious food poisoning and loss the food quality (Costa and Namal, 2019).

\* Corresponding Author: E-mail - [Chajayase@gmail.com](mailto:Chajayase@gmail.com)

A domestic refrigerator contains three separate compartments such as fresh food compartment, a frozen food compartment, and a crisper. The fresh food compartment is used for storing some fresh foods such as meat, fish, milk, eggs; some food preparations such as beverages, cooked meals, fresh desserts, salads; and some processed food products such as butter, cheeses, pasteurized milk, creams, yogurts, etc. The fresh food compartment is further subdivided into smaller zones. The mean temperature of the fresh food compartment is 4°C (SLS 1230, 2003) while it maintains the temperature range of 0 – 6°C. Meat keeper is a smaller zone of the fresh food compartment and the temperature is at approximately -1°C (Mascheroni and Salvadori, 2011).

Frozen food compartment is having a mean temperature not greater than -18°C, used for freezing foods or storage of frozen foods such as frozen desserts, mozzarella cheese, processed meat types, etc. The crisper is the compartment used for storing fresh fruits and vegetables aiming to retard the dehydration of fruits and vegetables. The temperature range of the crisper compartment is 2-12°C (SLS 1230, 2003). It maintains high humidity and it has a tight-fitting which helps in retarding product dehydration (Mascheroni and Salvadori, 2011).

There are several food quality and safety-related issues that occur during domestic refrigerator usage by householders. Food quality deterioration happens due to several reasons during domestic refrigeration such as temperature fluctuations, inappropriate selection of refrigerator compartments and thereby exposing the foods for incorrect storage conditions, inadequate packaging, inadequate cleanliness, microbial growth and potential cross-contamination, exposure to the freezing and cooling conditions for an excessive period of time and so on.

Temperature fluctuations happen owing to the increased frequency of door opening, inadequate defrosting, repetitive freezing and thawing, power disconnection or electricity interruptions which is a common occurrence in developing countries like Sri Lanka. Laguerre, Derens and Palagos (2002) found a relationship between the door opening frequency and the mean temperature inside the refrigerator. According to the study they found the highest temperature (8.1°C) at the highest number of door openings which was more than 20 times per day and the lowest temperature (5.1°C) when there were fewer door openings. When the refrigerator door was kept open for 10 s to 1 min, it takes around 2 to 10 min to recover the temperature (original temperature  $\pm$  1°C), and it depends on the type of refrigerator. When there are numerous door openings the time required to temperature recovery increases as well as the degree of temperature recovery is reduced (James and Evans, 1992).

Repetitive freezing and thawing processes which occur due to temperature fluctuations during cold storage causes food deterioration. Deng *et al.* (2020) have mentioned the loss of meat quality occurs as a result of the growth of ice crystals, weight loss, protein degradation, and the discoloration of fat and muscle. The thaw loss level was higher as proven by Deng *et al.* (2020), when there was a wider temperature fluctuation of frozen beef. Huang *et al.* (2006) have investigated and found a positive correlation between the rate of ice crystals growth and the range of temperature fluctuation. The tissue structure of food materials are destroyed due to the growth of ice crystals and thereby the nutrient loss as the drip is increased.

Galani *et al.* (2017) evaluated a reduction in total phenolics, vitamin C, and antioxidant activity of some fruits and vegetables during refrigerated storage for 15 days.

Different foods should be kept in different temperature zones in a refrigerator to maintain the quality until consumption (Table 1). The average temperature of many household refrigerators exceed the recommended 5 °C (40 °F) (Byrd-Bredbenner *et al.*, 2013). Refrigerator temperatures should not exceed 6 °C and the preferred temperature range should be between 2 and 4°C (WHO & FAO, 2009). James *et al.* (2017) reported that consumers around the world are often unaware of the recommended temperature for refrigerator storage and their refrigerator temperature. In a study carried out by Laguerre, Derens and Palagos (2002) in France, 80% of the refrigerators surveyed indicated the mean temperature was above 5°C (119 refrigerators out of 143). The mean temperature was 6.6°C, while the temperature range was 0.9°C to 11.4°C. Costa and Namal (2019) revealed the average temperature in the fresh food compartment in Sri Lankan domestic refrigerators is lower than 5°C. They found the temperature in the

freezer compartment to be within the range of -10 to -16°C in their study conducted on forty-one numbers of domestic refrigerators from different brands and models of inverter and non-inverter type. Byrd-Bredbenner *et al.* (2007) evaluated the mean temperature of  $6.1 \pm 3.6^\circ\text{C}$  in the refrigerator and  $-9.3 \pm 5.3^\circ\text{C}$  in the freezer compartment of domestic refrigerators.

Table 1: Suitable Storage Temperature of Some Food Products

Temperature	Food stuff
0-2 °C	Fish and seafood
+2 °C	Ground meat
+4 °C	Meat and meat preparations, cheese, fresh milk
+5 °C	Eggs
+8 °C	Stable meat products, Dairy products

Source: Laguerre, Derens and Palagos (2002) 3: 653–659

Studies signify that many domestic refrigerators are not adequately cleaned (Mori *et al.*, 2020, Macias-Rodriguez *et al.*, 2013 and Kennedy *et al.*, 2005). Microbial growth is also high due to the unhygienic condition. According to the findings of Kennedy *et al.* (2005), most of the domestic refrigerators in Ireland had  $7.1 \log \text{CFU}/\text{cm}^2$  and  $4.0 \log \text{CFU}/\text{cm}^2$  of average total viable counts and average total Coliform counts respectively. *Staphylococcus aureus* (41%), *Escherichia coli* (6%), *Salmonella enterica* (7%), *Listeria monocytogenes* (6%), and *Yersinia enterocolitica* (2%) were detected by analyzing swab samples in domestic refrigerators. *S.aureus* is the most abundant among the other types of microorganisms (Mori *et al.*, 2020, Kennedy *et al.*, 2005). The prevalence of these microorganisms was reported to be highest in the vegetable drawer (Mori *et al.*, 2020).

Some psychrotrophic fungi can grow inside a refrigerator at low temperatures. Unclean refrigerator interior, and exterior surfaces, un-cleaned raw foods, inadequately washed and packed food such as meats, eggs, and milk, refrigerator door left open and frequent opening, temperature fluctuations, are different sources of fungal contaminants (Otu-Bassey *et al.*, 2017). *Penicillium sp.*, *Cladosporium sp.*, *Mucor sp.*, *Aspergillus sp.*, *Schizosaccharomyces sp.*, *Rhizopus sp.*, *Alternaria sp.*, *Fusarium sp.*, *Trichosporon sp.*, *Botrytis sp.*, were food related fungal species identified from refrigerators during a study done by Fazelipour *et al.*(2020).

When addressing food quality-related issues during refrigerated storage in households, it is obvious that food wastage and food-borne diseases can be controlled by increased awareness. In Sri Lanka, a survey on the practices related to domestic refrigerator management has never been conducted to date. Therefore, the main focus of the study was to assess the practices linked to food quality and safety, knowledge of Sri Lankans related to domestic refrigerator handling, and to find out any relationships between the knowledge and awareness about refrigerator handling practices and socio-demographic characteristics.

## 2. MATERIALS AND METHODOLOGY

A cross-sectional study was conducted to assess the awareness of practices related to the usage of the domestic refrigerator for food storage in Sri Lankan families from June to August 2021. The respondents were representatives of families in Southern, Sabaragamuwa, Uva, Western, Central, and Eastern provinces in Sri Lanka. The study sample consisted of 342 respondents\*. The respondents represented Matara (63\*), Galle (37\*), Hambantota (19\*), Ratnapura (50\*), Kegalle(22\*), Badulla (51\*), Monaragala (15\*), Kalutara (31\*), Colombo (19\*), Gampaha (8\*), Nuwaraeliya (8\*), Kandy (5\*), Matale (2\*), Ampara (8\*), and Batticaloa (4\*) districts.

A questionnaire was developed after initial validation assessing the clarity of the content, the appropriateness of wording, the sequence of questions and the average time needed for its completion. The questionnaire took approximately 10 min to be completed. The purpose of the study was briefly explained to the respondents, and sought permission for inclusion of their responses in the survey.

The questionnaire was designed involving 30 questions to take information such as demographic characteristics (residence area, education level of the person who manages the cooking and refrigerator handling, monthly income of the family and household size), practices related to the use of the domestic refrigerator (food cleaning, placing, packaging and the selection of suitable temperature and compartment), and information about the refrigerator and its use conditions (type, refrigerator age, defrosting frequency, door opening frequency per day and cleaning practices).

**3. STATISTICAL ANALYSIS**

All data were analyzed descriptively using SPSS statistical software (version 28.0.0.0), and also to test significance, Chi-square ( $\chi^2$ ) statistical test was used. The differences were considered significant at  $P < 0.05$ . Chi-square test was conducted to see the associations between family income, level of education, and knowledge and practices of the respondents on food quality and safety related to refrigerated storage.

**4. RESULTS AND DISCUSSION**

Surveying the practices related to the usage of domestic refrigerators in Sri Lankan homes, especially those in the Southern, Uva, Western, Sabaragamuwa, Eastern and Central provinces make it possible to understand the extent of food quality deterioration during domestic cold storage.

The survey was conducted with 342 respondents. Among the respondents, 34.8% were from Southern province, 21.1% from Sabaragamuwa province, 19.3% from Uva province, 16.9% from Western province while 0.08% were from Central and Eastern provinces as shown in **Figure 2**. The majority of the respondents were earning less than Rs.150,000 monthly income (95%). Most of them (96%) were educated up to the primary, secondary and collegiate level of education with 4% having tertiary education level (Table 2).

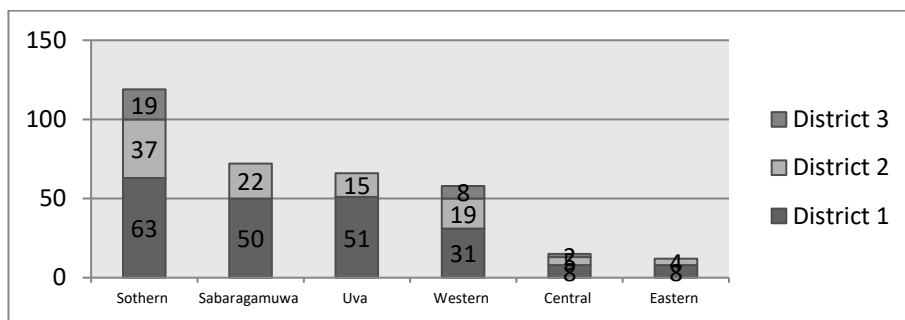

Figure 2: Respondents' Residential Provinces

Table 2: Socio-Demographic Data of the Respondents

Monthly income	Number of respondents / (percentage %)					
	≤ Rs.50,000		Rs.50,000- Rs.150,000		≥ Rs.150,000	
	240	(70%)	87	(25%)	15	(4%)
Education level of the person who is managing the food storage in home	Primary to secondary education		Collegiate education		Tertiary education	
	178	(52%)	150	(44%)	14	(4%)
Number of family members sharing the same refrigerator	≤ 3		3-5		≥ 6	
	41	(12%)	269	(79%)	32	(9%)

Almost all the respondents (93%) were using the domestic refrigerators for storing foods, which had low shelf life like fruits, vegetables, meat, fish, milk, and leftover foods. Even foods with long shelf life like honey, jam, tamarind, flour and pickles were also stored by few respondents (7%).

#### 4.1 Temperature Fluctuation and the Quality of Stored Foods

Temperature fluctuation of the refrigerator has an important impact on food quality loss leading to food wastage and refrigerated food-borne diseases (Rodriguez-Martinez *et al.*, 2019). It can be manifested as unfavourable changes of organoleptic qualities, microbial quality, nutritional properties, and other chemical and physical changes. Several mal-practices of domestic refrigerator usage such as high frequency of the door opening, inappropriate defrosting, disconnecting the power supply due to several reasons, time to time withdrawal of food products and keeping the rest back in the refrigerator, etc affect the food quality loss. Repetitive freezing and thawing of meat and fish direct to a greater degree of nutritional loss and microbial spoilage. Re-crystallisation of Ice-cream leads to the loss of texture. Both the above-mentioned incidents are results of temperature fluctuation. The survey results showed 59.7% opened the refrigerator door more than ten times per day. The frequent door opening can alter the temperature of different refrigerator compartments which is not acceptable. Less frequent door opening can minimize food quality loss while saving energy.

Based on the results from the survey, 26% of the respondents had single-door refrigerators at home. The freezer and the fresh food compartment consist together in single-door refrigerators. Therefore the freezer is exposed to an elevated temperature when the refrigerator door is opened frequently. The remaining 74% of respondents had two-door refrigerators. Refrigerator compartments are separated in this type of refrigerators. Compartments are opened depending on the requirement. It is advantageous to minimize the temperature fluctuations that the food is exposed.

Manual defrosting type refrigerators should be defrosted in frequencies proposed by the refrigerator manufacturer because of the defrosting aids in maintaining the optimum temperature in different compartments. Surveyed results found that 21.6% defrosted the refrigerator rarely which is an unacceptable practice.

Time to time withdrawal of food items and placing the rest back in the refrigerator is another mal-practice where 35.7% practiced it regularly. It is suggested to clean the food item and place the required quantity in separate clean containers in the refrigerator with the intention of only withdrawal of foods according to the daily requirements.

The age of the refrigerator has an important role in the thermal behaviour in the food compartments (Janjić *et al.*, 2015). Among the respondents, 24% had refrigerators of more than 10 years which may perform less in temperature management. The temperature measuring feature was not there in the refrigerators of 51.8% of respondents.

#### 4.2 Cleanliness and the Quality of Stored Foods

Cleanliness is another important factor affecting the quality of food stored in the refrigerator. Here the cleanliness can be discussed in three aspects such as the cleanliness of food items, refrigerator interior, and the packaging used to cover foods before storing.

Fruits and vegetables should be cleaned and decayed or rotten parts which accelerate the microbial activity should be removed before storing. A considerable percentage of respondents (42%) did not clean fruits and vegetables before storing. Shells of the eggs are a potential source of pathogenic microorganisms such as *Salmonella* and *Escherichia coli* (*E. coli*) (Chousalkar *et al.*, 2010). Therefore washing eggs before keeping them in the refrigerator is important to remove those microorganisms. It was observed that this fact is not grabbed by people as 58.2% of survey respondents did not wash eggs prior to storing. Meat and fish are good nutrient sources for microbes to grow much faster. Blood, intestinal parts, skin, scales like unwanted parts removal is a way to control their deterioration even in domestic cold storage. This facilitates controlling the microbial load in the refrigerator and possible cross-contamination. The survey revealed that 46% of respondents did not practice cleaning meat and fish prior to storage.

Cleaned fresh foods should be packaged in clean containers before storing. Polypropylene and polyethylene bags are used to decrease quality losses of fresh fruits and vegetables during cold storage (Onwude *et al.*, 2020). Low-density polyethylene (LDPE) is emphasized due to some features such as flexibility, transparency and resistance to moisture (Carbone *et al.*, 2016). Stainless steel and glass containers are better options for avoiding microbial influence (Kaur, Sandhu and Sidhu, 2013). Most of the respondents (56%) used shopping bags or zip lock bags to store fruits and vegetables while 6% did not cover them to facilitate dehydration and wilting of fresh fruits and vegetables.

Refrigerator interior cleaning should be done frequently using a suitable disinfectant (Düven, Tiryaki Gündüz and Kışla, 2021). Microbial growth, unpleasant odours development and food spoilage are consequences of inadequate cleaning (Rodriguez-Martinez *et al.*, 2019). The majority of the (59.9%) respondents reported that they cleaned the refrigerator once a month but only 10% were following the most suitable practice of cleaning once a week. Only a few respondents (12%) cleaned the interior of the refrigerator having awareness about cross-contamination. There were 2.3% of respondents who cleaned the refrigerator rarely. It was observed that people do not have an idea about the cleaning agents which should be used in refrigerator interior cleaning as a considerable percentage of respondents (28%) used only portable water for the cleaning purpose whereas 53% used dishwashing liquid soap.

### 4.3 Selecting the Most Suitable Refrigerator Compartment and the Quality of Stored Foods

Food items should be kept in the most suitable compartment in the refrigerator to provide the most suitable storage conditions like temperature and humidity. The survey results found that 5% selected unsuitable compartments for storing meat and fish which are highly perishable. Mis-selection not only lose the quality of meat and fish but also drags the entire food item's quality into danger. Fresh fruits and vegetables should be kept in the crisper compartment at 2-12°C in high relative humidity and it is not practiced by 42.8% of respondents.

Table 3: Food Storage Compartment Selection Data.

Food category	Number and percentage(%) of respondents											
	Freezer compartment		Fresh food compartment –top shelf		Fresh food compartment –middle shelf		Crisper		Door		No particular place	
<b>Fruits and Vegetables</b>	0		47	(13.7%)	12	(35.4%)	15	(44.4%)	4	(1.2%)	1	(5.3%)
<b>Raw Meat and Fish</b>	11	(34.2%)	20	(60.8%)	9	(2.6%)	5	(1.5%)	0		3	(0.9%)
<b>Raw milk</b>	0		29	(8.5%)	10	(29.8%)	16	(4.7%)	19	(57.0%)	0	
<b>Eggs</b>	0		5	(1.5%)	21	(6.1%)	0		28	(83.0%)	2	(6.4%)
<b>Left over foods/ cooked foods</b>	13	(39.7%)	96	(28.1%)	82	(23.9%)	0		0		2	(8.1%)
<b>Frozen desserts</b>	32	(96.2%)	8	(2.3%)	0		0		5	(1.5%)	0	
<b>Yoghurt and butter</b>	0		19	(5.6%)	23	(68.2%)	15	(4.4%)	75	(21.9%)	0	
<b>Cheese</b>	52	(15.2%)	15	(46.5%)	16	(4.7%)	26	(7.9%)	86	(25.2%)	3	(0.9%)
<b>Processed meat based products</b>	22	(64.9%)	84	(24.6%)	29	(8.5%)	3	(0.9%)	0		4	(1.2%)

#### 4.4 Association between Education and Economic Level on Food Safety Practices in Domestic Refrigerator Management

In this study, a significant association ( $P < 0.05$ ) was observed between the level of education and practices of households. A significant association could be observed in egg washing before storing ( $p = 0.037$ ). Fresh fruits and vegetables wrapping in suitable packaging materials, selecting the most suitable compartment for food storage, and consumption of opened packed foods before the expiry date were also showed a significant association with the level of education. However, there was no significant association between these practices according to the economic status (evaluated by monthly income).

#### 5. CONCLUSION

Food quality deterioration happens due to several reasons during domestic refrigeration such as temperature fluctuations, inappropriate selection of refrigerator compartments and thereby exposing the foods for incorrect storage conditions, inadequate packaging, inadequate cleanliness, microbial growth, and potential cross-contamination, exposure to the freezing and cooling conditions for an excessive period of time and so on. This study concluded that the loss of food quality, incidences of refrigerated food-borne diseases and food wastage during domestic cold storage are due to the mismanagement of domestic refrigerators. It is a result of inadequate knowledge. The knowledge gap regarding the selection of the most appropriate refrigeration temperature and refrigerator compartment, potential cross-contamination and prevention methods, the importance of good hygienic practices can be overcome by providing proper awareness.

#### REFERENCES

- Byrd-Bredbenner, C., Berning, J., Martin-Biggers, J. and Quick, V., 2013. Food Safety in Home Kitchens: A Synthesis of the Literature. *International Journal of Environmental Research and Public Health*, 10(9), pp.4060-4085.
- Byrd-Bredbenner, C., Maurer, J., Wheatley, V., Cottone, E. and Clancy, M., 2007. Food Safety Hazards Lurk in the Kitchens of Young Adults. *Journal of Food Protection*, 70(4), pp.991-996.
- Carbone, M., Donia, D.T., Sabbatella, G. and Antiochia, R., 2016. Silver Nanoparticles in Polymeric Matrices for Fresh Food Packaging. *Journal of King Saud University - Science*, 28(4), pp.273-279.
- Chousalkar, K.K., Flynn, P., Sutherland, M., Roberts, J.R. and Cheetham, B.F., 2010. Recovery of *Salmonella* and *Escherichia coli* from Commercial Egg Shells and Effect of Translucency on Bacterial Penetration in Eggs. *International Journal of Food Microbiology*, 142(1-2), pp.207-213.
- Costa, G. and Namal, D., 2019. Analysis of Energy Efficiency of Domestic Refrigerators. *Engineer: Journal of the Institute of Engineers, Sri Lanka*, 52(3), p.43.
- Deng, S., Han, Y., Gao, T., Ye, K. and Liu, J., 2020. Effect of Temperature Fluctuation during Frozen Storage on Beef Quality. *Journal of Food Processing and Preservation*, 45(1).
- Düven, G., Tiryaki Gündüz, G. and Kışla, D., 2021. Determination of Hygienic Status of Refrigerators Surface. *Food and Health*, 7(4), pp.251-258.
- Evans, E.W. and Redmond, E.C., 2015. Analysis of Older Adults' Domestic Kitchen Storage Practices in the United Kingdom: Identification of Risk Factors Associated with Listeriosis. *Journal of Food Protection*, 78(4), pp.738-745.
- Fazelipour, M., Neisi, A., Alizadehattar, S. and Kiasat, N., 2020. Isolation and Identification of Psychotropic Fungal Contamination in Food Storage Refrigerators in Ahvaz City Restaurants. *Jundishapur Journal of Health Sciences*, 12(2).
- Flynn, O.M.J., Blair, I. and McDowell, D., 1992. The Efficiency and Consumer Operation of Domestic Refrigerators. *International Journal of Refrigeration*, 15(5), pp.307-312.
- Galani, J., Patel, J. S., Patel, N. J., and Talati, J. G., 2017. Storage of Fruits and Vegetables in Refrigerator Increases their Phenolic Acids but Decreases the Total Phenolics, Anthocyanins and Vitamin C with Subsequent Loss of their Antioxidant Capacity. *Antioxidants (Basel, Switzerland)*, 6(3), p.59.



- James, C., Onarinde, B. A., and James, S. J., 2017. The Use and Performance of Household Refrigerators: A Review. *Comprehensive Reviews in Food Science and Food Safety*, 16(1), pp.160–179.
- James, S.J. and Evans, J., 1992. The Temperature Performance of Domestic Refrigerators. *International Journal of Refrigeration*, 15(5), pp.313–319.
- Janjić, J., Katić, V., Ivanović, J., Bošković, M., Starčević, M., Glamočlija, N. and Baltić, M.Ž., 2015. Temperatures, Cleanliness and Food Storage Practises in Domestic Refrigerators in Serbia, Belgrade. *International Journal of Consumer Studies*, 40(3), pp.276–282.
- Kaur, G., Sandhu, P. and Sidhu, M., 2013. Microbial Analysis of Commonly Stored Food Items in Household Refrigerators in Selected Containers. *Journal of Human Ecology*, 41(2), pp.151–155.
- Kennedy, J., Jackson, V., Blair, I., McDowell, D., Cowan, C. and Bolton, D., 2005. Food Safety Knowledge of Consumers and the Microbiological and Temperature Status of Their Refrigerators. *Journal of Food Protection*, 68(7), pp.1421-1430.
- Kilonzo-Nthenge, A., Chen, F. and Godwin, S., 2008. Occurrence of *Listeria* and Enterobacteriaceae in Domestic Refrigerators. *Journal of Food Protection*, 71(3), pp.608-612.
- Laguerre, O., Derens, E. and Palagos, B., 2002. Study of Domestic Refrigerator Temperature and Analysis of Factors Affecting Temperature: A French Survey. *International Journal of Refrigeration*, 25(5), pp.653–659.
- Macias-Rodriguez, M., Navarro-Hidalgo, V., Linares-Morales, J., Olea-Rodriguez, M., Vollarruel-Lopez, A., Castro-Rosas, J., Gomez-Aldapa, C. and Torres-Vitela, M., 2013. Microbiological Safety of Domestic Refrigerators and the Dishcloths Used To Clean Them in Guadalajara, Jalisco, Mexico. *Journal of Food Protection*, 76(6), pp.984-990.
- Mascheroni, R. and Salvadori, V., 2011. Household Refrigerators and Freezers. In: *Handbook of Frozen Food Processing and Packaging*.
- Mori, M., Sakagami, Y., Tanaka, M., Inoue, R. and Jojima, T., 2020. Analysis of the Relationship of Microbial Contamination with Temperature and Cleaning Frequency and Method of Domestic Refrigerators in Japan. *Journal of Food Protection*, 83(7), pp.1234-1240.
- Onwude, D.I., Chen, G., Eke-emezie, N., Kabutey, A., Khaled, A.Y. and Sturm, B., 2020. Recent Advances in Reducing Food Losses in the Supply Chain of Fresh Agricultural Produce. *Processes*, 8(11), p.1431.
- Otu-Bassey, I., Ewaoche, I., Okon, B., Ibor, U., 2017. Microbial Contamination of House Hold Refrigerators in Calabar Metropolis-Nigeria. *American Journal of Epidemiology and Infectious Disease*, 5(1), pp.1–7.
- Rodriguez-Martinez, V., Velazquez, G., Massa-Barrera, S., Welti-Chanes, J., Fagotti, F. and Torres, J.A., 2019. Estimation of Safety and Quality Losses of Foods Stored in Residential Refrigerators. *Food Engineering Reviews*, 11(3), pp.184–199.
- SLS 1230:2003. Sri Lanka Standard Institution, Energy Efficiency Ratings of Household Refrigerator-Freezer and Freezer.
- Statista. 2021. *Sri Lanka-sales volume of refrigerators 2016/ Statista*. [Online] Available at: <https://www.statista.com/statistics/857202/sri-lanka-sales-volume-of-refrigerators> [Accessed 27 August 2021]
- WHO, & FAO., 2009. Food hygiene (basic texts) (4th ed.). Rome, Italy: World Health Organization, Food and Agriculture Organization of the United Nations.

## **TEACHING AND LEARNING ENVIRONMENTS**

# Collaborative E-Learning Applications in the Sri Lankan Vocational Education

K.P.I.S. Jayasekara\*, C.P. Danthanarayana, K.A.I.M Amarasekara, A.P.R.P. Pathirana

Division of Management Studies, University College of Matara, Sri Lanka

## ABSTRACT

*The usage of collaborative e learning methods plays a significant role in vocational education when achieving effective learning processes. The present study was conducted as a review on empirical research focusing the collaborative e-learning applications in vocational education in Sri Lanka. The review has focused on the reality of using collaborative e learning applications, factors affecting collaborative e-learning, its effectiveness, benefits and the challenges in vocational education in Sri Lanka. With the collaborative e learning applications, the traditional boundaries could be eradicated i.e., physical presence, time boundaries, cost boundaries, etc. It could be identified that, the application of various technological tools speeds up the education process from both the teachers' and learners' perspective. Further the collaborative e learning positively affects the development of TVET sector in Sri Lanka. However, it could be identified that lack of ICT related infrastructure and awareness on collaborative e-learning are the major challenges in vocational education in Sri Lanka.*

**Keywords:** Collaborative e-learning, Effectiveness, Vocational Education.

## 1. INTRODUCTION

Vocational education has been identifying as an important factor in directing trained human resource in to various industrial, service and technical sectors. Many of higher educational institutions are aiming at establishing synergized interaction between the trainees and industries in order to achieve standard in human power, effectiveness and efficiency as well. Within the higher education context in Sri Lanka, vocational education has acquired a considerable attention from the government during the recent past. It is obvious that the advancement in information and communication technology gradually took place in tertiary, secondary and primary education system and as well in vocational education. Further using various technologies has become a trend recently and has rapidly grown with the COVID 19 outbreak. In order to adapt to the new normal situation, education systems in many countries around the world converted their usual practice in to an online manner. However at the beginning, the low level of awareness and familiarity to the information and communication technological tools lead the process rather weaken and steadily adaptation was embraced in to a certain extent. Traditionally Sri Lankan educational system comprises direct contacts between trainer and trainee within a physical environment aiming to improve the relationship and performance between both parties. Nevertheless with the unforeseen epidemic situation which took over, it was realized that the tradition can no longer be practiced and it is the level to uplift the education in to a modernized mode. Blurton (1999) defined as cited by Ben and Ashang (2013) that information and communication technology used to manage information with broadcasting and telephony resources and technologies. Vocational technical education designed to develop attitudes, skills, knowledge and abilities required by an employee in a productive and useful way. (Mbata and Robert in Ben, 2010 as cited by Ben and Ashang, 2013). Therefore a need arose for merging these two edges together and to develop a virtual classroom for vocational education.

Collaborative e-learning has been utilized by various state and non-state higher educational institutions of many countries including Sri Lanka. According to Toner (2010) vocational education and training sector focuses on fulfilling the requirements of industries and of students in the region where the colleges are located. And vocational education is based highly on delivering practical based skills to

---

\* Corresponding Author: E-mail - [88shashin@gmail.com](mailto:88shashin@gmail.com)

the learners. Hence studies should be targeted on the unaddressed problem of the skill level gained through collaborative e-learning in vocational education compared to the skill level gained in a laboratory, field visit or any physical setting in vocational education. As vocational education mainly aiming at developing learners' skills and practical knowledge towards a particular industry it is essential to study the various challenges encountered from the trainers' and learners' perspectives to develop a mechanism to overcome them. Hayashi, Garcia, Maddawin, and Hewagamage, 2021 have positively argued that online education is possible on philosophical education system. However there is a lack in studies and researches to study the application of collaborative e-learning in vocational education, challenges occur in delivering the practical based exercises to the learners and to study the competence level gained through online education in vocational education sector in Sri Lankan context. The objectives of the study were to identify; the reality of using technological applications in vocational education, the factors affecting collaborative e-learning in vocational education, the effectiveness and benefits of collaborative e-learning in vocational education and the challenges of using collaborative e-learning in vocational education in Sri Lanka. This study has conducted by analyzing the past literature and mainly based on the findings of past researches. It is depending on the qualitative data gathered by previous researchers and both students' and lecturers' perspective has discussed in the study.

As the significance of the study, vocational education is an essential element in producing eligible human resource to cater various employment needs in various industrial and service sectors. Many of technology based higher educational institutions have been established which offer certificate level, diploma and higher national diploma level and degree level qualifications structured on different conditions. Considering the investment on vocational education it is compulsory to generate an appropriate work force with practical knowledge. With the current pandemic situation majority of the vocational educational institutions have been practicing online mode in sharing knowledge. Therefore it is mandatory to study the practical challenges of applying e-learning applications in vocational education and as well to find challenges in delivering vocational education to the learner. On this regard the study is aiming to solve research questions to achieve the research objectives to create a proper mechanism that is appropriate for vocational education. Further identification of challenges can be used in policy making related to e-learning applications for rural communities.

## **2. LITERATURE REVIEW**

### **2.1. Definition of Technology, ICT and Collaborative E-Learning**

Even though there are many arguments of defining the term "technology", many researchers have defined technology in different way. As per the view of Brey (2009), as cited in Carroll (2017) though it is a challenging task to develop proper definition for the term technology, people do certainly know what it is and can distinguish between things that are occur naturally and man-made things. According to Volti (2009), as cited in Coccia (2019), technology is defined as "a system designed by humans that uses knowledge, information and organization to yield techniques and objects for the purpose of achievement of specific goals". Further as per the findings of Isman (2012), technology is the practical application of knowledge especially in a specific field and is a way of performing a task especially using processes, methods or technical knowledge. "Information and Communication Technology" (ICT) first appeared in the mid-1980s and was defined as all kinds of electronic systems used for personal computers, video games, cell phones, the Internet and telecommunications, and intermediate communication. Electronic payment systems and computer programs. (Pal and Sonker, 2013) However in today, the definition for ICT is much comprehensive and complex, and there is huge involvement of almost all types of businesses. From manufacturers, retailers, banks and publishers to research institutes, medical institutes, law enforcement agencies, government agencies and libraries everywhere, IT and ICT employees depend on them to run their day-to-day business. Mocanu and Deaconu (2017) ICT is defined as a set of different tools and resources used to create, disseminate, store and manage information. Collaborative E learning (CeL) can be defined as "the acquisition of knowledge or the resolution of problems through the interaction of two or more learners in a coordinating effort using the Internet and electronic communications for their interaction".

## 2.2 Vocational Education in the Global Context

Skills are crucial for poverty reduction, economic recovery and sustainable development. As a result, the political awareness of technical and vocational education (TVET) is increasing around the world. TVET includes formal, non-formal and informal learning for working life. Young people, women and men acquire basic to advanced knowledge and skills in a wide range of institutional and professional environments and in different socio-economic contexts. Sulaiman et al (2017) mentioned that due to highly competitive global world, Technical and Vocational Education (TVE) is facing new challenges in today's world. Wagiran, Pardjono, Suyanto and Sofyan (2017) stated that in an international context, vocational education continues to evolve and with the advancement of science and technology requires innovation and creativity, thereby producing only ready-to-use labor in the world of work. In addition, vocational education in the international context continues to evolve into a scientific discipline.

Many researchers (King and Palmer, 2006; Cheng, 2010; Cambodia and Wallenborn, 2009) have proven that vocational training (VET) is seen as an important step towards self-employment, entrepreneurship development, human capital for the economy development increased productivity, and contributions to economic growth. It is further perceived as an important tool towards social development, citizenship and sustainability (UNESCO, 2004). However, a recent Global Marginalization Monitoring Report underscores the importance of thinking about how EUDs can help solve this complex problem (UNESCO, 2010). GMR defines the grassroots as those who do not have equal access to resources due to various social and economic inequalities, including poverty, class, race, gender, livelihood, position, conflicts and colonialism. RMS indicates that RE plays an important role in "strengthening the transition from school to the work world, providing a second chance and combating marginalization" (UNESCO, 2010). Considering the technical and vocational education and training (TVET) system in India, various ministries are trying to spread vocational education through innovative institutions specially designed for this purpose. In doing so, the government seeks to maintain the quality of these courses. In the Eleventh Plan, vocational education was encouraged with more funds allocated for this purpose. In addition, these courses ensure proper representation of the lower strata of society, including women. It is therefore to be hoped that TVET will play a major role in improving the lives of the Indian people. (Goel, 2008)

## 2.3 Use of Collaborative E-Learning in Vocational Education in the Global Context

In the global context, currently there are different e-learning tools such as Moodle, messaging tools, online conferencing tools, online chat tools, community platforms, wiki, forum posts, tablet platforms, etc which are used to deliver CeL facilities (Kanaganayagam and Fernando, 2013). As per the view of Maričić, Haber, Radolović and Veljović, (2019) the application of various technological tools in the educational process speeds up the teaching process and makes it more exciting and acceptable. The knowledge that students should have at the end of school education is changing rapidly. United Nations Educational, Scientific and Cultural Organization (2003), in their analytical report mentioned that many researchers have emphasized the importance of using technology especially in vocational education. According to them, technology-enhanced learning plays a critical role in building a lifelong learning culture, empowering learners with a variety of options and options to respond to their educational and training needs (Human Resource Development Canada, 1998). So it is not surprising that there is a growing interest in technology-based learning (TBL) around the world. TBL is a group of hardware and software used in teaching and learning systems, including computer training systems, multimedia systems, electronic activation support systems, training systems, telecommunications, and the World Wide Web. The speed of internet access is increasing at lightning speed. TBL can improve teaching and learning; it has the potential to be cost effective as it provides greater flexibility when and where training is provided (First-Bow, 1996). In addition, corporate policy on access and fairness to the TBL can be facilitated (Lafrenier, 1997). Technology provides greater flexibility for teaching and learning to adapt to learners' cognitive and learning methods. Maxwell (2019) mentioned that, every industry around the world is changing rapidly, and education is no exception. Over the past five years, the field of Vocational Education and Training (VET) has come face to face with the transition to a number of

courses online learning, but a revolution is taking place in our field of education as concepts such as gambling and virtual reality are implemented.

Even though the transition rate is higher according to online surveys (Hayashi, Garcia, Maddawin, and Hewagamage, 2021) there are few challenges identified which direct to decrease the effectiveness and efficiency of the process. Mocanu and Deaconu (2017) identified that poor internet connections and disruption in internet access as major challenge to this transition and argued that delivering practical based knowledge is an additional challenge for vocational education as laboratory trainings are hard to complete and limited involvement of students via online platform. Ahmadi and Reza (2018) discussed that teachers should be persuaded with the benefits that technology can offer for the betterment of learners' learning. Further summarized that technology creates the interaction among teachers and learners as well help learners to improve their thinking skills in language learning. Moreover, in early days, online learning platforms were a repository for digital course notes rather than greatly enhancing the learning experience. As a result, in the VET segment, completion rates for online courses were lower than face-to-face levels. But with the advancement of technology comes a significant change in its opposite direction.

#### **2.4 Vocational Education in the Sri Lankan Context**

The government of Sri Lanka incurs considerable expenditure on school education, higher education and also on Technical and Vocational Education and Training (TVET) system in the country. TVET works toward producing skilled personnel in occupations of many industries. School education creates general human capital and TVET creates specific human capital. Human capital plays a major role in production process and hence the government is responsible for improving the human capital. The TVET system in Sri Lanka consists of a number of agencies, including public and private sector education providers, standards and curriculum development agencies and a supervisory body, the Tertiary and Vocational Education Commission under the Ministry of Youth. The National Apprenticeship and Industrial Training Authority (NAITA) and the University of Vocational Technology (UNIVOTEC) were formerly known as the Institute of Technical Education of Sri Lanka (NITESL). UNIVOTEC was established in 2008 for the purpose of providing diploma training to those passing through the NVQ system, as well as to those pursuing and pursuing diploma training in the industry; NITESL became a faculty member of UNIVOTEC in accordance with the provisions of the UNIVOTEC Act. NAITA is the most important apprenticeship training agency. It manages three (03) national educational institutions. Apprentice Training Institute (ATI), Institute of Automotive Engineering Training (AETI) and Institute of Engineering Technology (IET). The Department of Technical Education and Training (DTET) operates thirty eight technical colleges across the country by the end of 2009, of which nine (09) colleges have been upgraded to Colleges of Technology (CoTs) to offer diploma courses leading to national vocational qualifications (Gajaveera, 2010). Sri Lanka has made substantial growth in technical and vocational education and training (TVET) over the past three decades, particularly regarding institutional and policy support, three linkages with industry and the donor community, and establishing a National Vocational Qualifications Framework (NVQF) and labor market information system. However, issues remain including inadequate awareness of NVQF, lower completion rates, unsatisfactory implementation of strategic plans, insufficient financial allocation, and need for more meaningful industry participation. (Maurer, 2012)

#### **2.5. Use of Collaborative E-Learning in Vocational Education**

At present, there are number of institutes in Sri Lanka which are offering vocational education and even though there is advance technology in current situation, the vocational education system in Sri Lanka is still using traditional face-to-face delivering methods to teach the courses (Basu, 1997). However, with the COVID-19 pandemic vocational institutes also started online teaching at their course delivery. In the Sri Lankan education system, collaborative e-learning is a renowned concept as it integrates with learning through internet to get the highest effectiveness of the concept (Kanaganayagam and Fernando, 2013). As suggested by Yasak and Alias (2015) CeL approach can be considered as most effective method in TVET and it considerably enhances learner performances. With clear and constant communication activities, technological collaboration and learning maturity supports to effective virtual

community (Jayalath and Esichaikul, 2020). In vocational education, practical sessions require instructor engagement in workshops and laboratories in high level, which allow hands-on experience for candidates to gain required skills and competencies required to maintain learner progress (Jayalath and Esichaikul, 2020). Learning progress in that type of vocational courses depends on several elements such as satisfaction (Browne, 2019), self-motivation of learners (John and Duangekanong, 2018), and engagement (Lister 2015). For the success of collaborative learning, positive attitude, and awareness of technological applications is required (Kanaganayagam and Fernando, 2013). Past study conducted among 23 Sri Lankan educational institutes identified that, quality of CeL can be improved with the enhancement of interactivity (Gamage and Fernando, 2012). Moreover, that study revealed that, 86% of Sri Lankan educational institutes are desire towards CeL and according to the results that was suggested to combine traditional classroom-based face-to-face teaching with CeL methods while using modern technology. There are large number of CeL tools which are applicable into the vocational education in Sri Lanka. E-learning applications can be classified in to two types as; production tools and learning tools (Kanaganayagam and Fernando, 2013). Internet, web-based technology, and cloud technology is considered to be used as a teaching resource (Marikar and Jayarathne, 2016). These e-learning platforms allow real-time interaction among lecturers and students, and allow them to evaluate the effectiveness of leaning activitis as well as student's performance (Beatty and Ulasewicz, 2006). Virtual Learning Environment (VLE) is teaching and learning software which allows communication, upload the lecture material, share the student works, administration of student groups, assessment of their tasks and etc. over internet (Weller, 2007). Apart from that, recently some institutes are using MOODLE platform, Google classroom, Zoom technology, Microsoft Teams to interact with students in the academic activities. Learning Management System (LMS) is CeL activities in higher educational institutes and however, in the vocational education there are very limited institutes which are using LMS at their academic activities (Kuruppu, and Halwatura, 2013).

## **2.6 Effectiveness and Benefits of Using Collaborative E-Learning in Vocational Education**

The effectiveness of CeL depends on the tools, techniques and methods used in CeL. It enhances participant's motivation and psychological arousal while allowing their ability to process the information (Kanaganayagam and Fernando, 2013). It is important to evaluate the effectiveness of CeL and it can be conducted through five evaluation measures; material contents, guide and follow-up, teaching design, media application, and evaluation and feedback which is suggested by the E-Learning Quality Certification (eLQCC) (Ray and Shu-Li, 2010). According to the findings of past researchers (Kanaganayagam and Fernando, 2013), compared with traditional classroom teaching methods, CeL eliminates time and geographical boundaries; there is no need of physical presence in the location as there are lack of infrastructure facilities available for physical learning in TVET sector in Sri Lanka, and it allows students to connect with skilled lecturer who located in the distant location through e-tools; it saves time and lecturer is able to monitor and evaluate performance of each and every student online after giving group tasks; it allows students to actively engage in problem solving and improve their soft skills. In the student's perspective CeL improve their knowledge and understanding through online discussions among students and accessing study materials which are available online. Subjects can be revised following to the new trends in the specific field. It decreases the material printing cost since study material can be referred on their screens (Kanaganayagam and Fernando, 2013).

CeL effectively contributes in socially, academically and psychologically in vocational education in Sri Lanka. Mainly it helps to enhance the effectiveness of problem-solving skills of the students while inspiring the critical thinking of them; it will affect the social interactions and encourage the social diversity among students; it causes to enhance the interpersonal relationships among students and lecturers; Since CeL supports the independent learning culture, it affects to the development of self-management skills of students in vocational sector in Sri Lanka (Słowikowski, et al., 2018). They are showing positive attitudes towards CeL. CeL made large content accessible for large audience which spreads over long distances. It offers greater flexibility for students and ability to personalize the learning content and methods. CeL tools and techniques such as presentations, animations, interactive and realistic exercises will support student's motivation to learn (Belaya, 2018). Apart from that, there can be some negative impacts of CeL on vocational education in Sri Lanka. According to the study

done by Belaya (2018), it can identify negative impacts of CeL on vocational education. With the usage of computers and internet, it can be caused to health problems and participants may experience isolation at their learning process. Learning at virtual classrooms are challenging than face-to-face learning at physical classrooms in communication. Because of that, learners are able to develop social skills up to limited extend. Misunderstanding can occur due to the communication by using virtual platforms and it can be adversely affecting the learning process. Since the skills and practical exposure dominating the vocational education, CeL negatively effect on delivering the job-related skills which leads to lack of practical knowledge and experience of candidates.

## **2.7 Factors Affecting Collaborative E-Learning in Vocational Education in Sri Lanka**

As per the findings of past researchers, there are different factors affecting CeL in vocational education in Sri Lanka. Instructional material, tutorial support, communication and collaboration are can be considered as most influencing factors in CeL (Gunawardana, 2005). Further he has identified the importance of availability of the infrastructure with the internet connectivity in both urban and rural areas, and easy access to all study material with internet access to their home or public internet centers (Gunawardana, 2005). Further, in the results of Kanaganayagam and Fernando (2013), it also identified several factors and it has categorized these factors into nine categories as; students' skills, students' attitude, lecturers' skills, lecturers' attitude, availability of non-electronic resources, electronic tools & electronic resources, government & administration, subject content, and teaching approach. According to these findings most effective factors can be considered as electronic tools and resources related factors and also students' attitude related factors such as perception, motivation and willingness (Kanaganayagam and Fernando, 2013). Apart from that, there are other factors influencing the CeL such as skills related factors of students and accessibility of non-electronic resources (Kanaganayagam and Fernando, 2013). These findings are positively relate with the findings of the research done by Arachchi et al. (2005) as they suggested that, students are required to be able to access internet, and they should be more motivated and positive thinking candidates for effective CeL. Apart from that, students must have a high level of self-discipline, good time management skills and concentration on lessons to control the learning process independently (Belaya, 2018).

## **2.8 Challenges of Using Collaborative E-Learning in Vocational Education in Sri Lanka**

There can be lot of challenges faced by lecturers as well as students in using CeL applications in vocational education. Some of the key challenges are, lack of essential resources such as infrastructure, electronic devices and tools, and enough time; lack of uninterrupted network connection for both lecturers and students; lack of awareness on CeL applications and usage of electronic tools among both lecturers and students; lack of administration support to obtain financial support to implement CeL applications (Kanaganayagam and Fernando, 2013). Apart from that, getting student support, lack of flexibility, lack of teaching and learning activities, access problems, and lack of academic confidence, localization and negative attitudes also can be considered as key challenges in CeL in vocational education (Andersson, 2008). Some of the lecturers are not much ready to use CeL applications since lecturers have to undertake additional workload; they have to overcome the issues related with students' cultural aspects, they have to create CeL culture, and they have to convert students from passive learners to active learners since CeL require active learners to be successful (Kanaganayagam and Fernando, 2013). Especially in the vocational education, there is a requirement of providing practical experience in the laboratories or practical work environment. Overcome that issue is also one of the key challenge from lecturer's perspective (Gunawardana, 2005). In the students' perspective, lack of computer knowledge and internet facilities; difficult to focus on CeL applications than physical lectures since students are passive learners, not prefer to ask questions in online sessions than physical classes; lack of interest since they perceive CeL is self – learning method, and little exposure to CeL practices can be seen as key challenges of using CeL in vocational education (Kanaganayagam and Fernando, 2013).



### 3. CONCLUSION AND RECOMMENDATION

Vocational education plays one of the major roles in making a creative and skillful labor force ready to employ in the business environment. The application of technological tools provides flexibility for both learners and teachers while it speeds the teaching process. Also, it helps in building a lifelong learning culture and, empowers the learners with more productivity. Further, the TVET sector shows a good tendency in grabbing the opportunities of collaborative e-learning methods with the recent changes and advancements of technology. As per the first objective of the research it has identified the reality of using technological applications in vocational education. Accordingly collaborative e-learning applications were identified as factors motivating the participants to engage in collaborative e-learning and determining its effectiveness. On one hand, it eradicates the traditional boundaries like the physical presence, time boundaries, cost boundaries, etc., enabling the students to contact skilled lecturers, and on the other hand, lecturers to save time in monitoring, performance evaluation, and make a good platform for student discussions, writing answers and building soft skills. It can be concluded that use of collaborative e-learning applications in vocational educations in Sri Lanka is at a developing stage. When focusing to the factors affecting the collaborative e learning as second objective of the study, it could be identified that the instructional material, tutorial support, communication, collaboration and, the availability of ICT and related infrastructure in both urban and rural areas as important factors that determine the effectiveness of collaborative e learning. Moreover, it was identified that the knowledge, skills and attitudes of the students' as well as of the lecturers' also affect the effectiveness of collaborative e-learning process. As per the third objective it was identified the effectiveness and benefits of collaborative e-learning in vocational education in learners' and teachers' perspectives. Accordingly it can be concluded that CeL effectively contributes in socially, academically and psychologically in vocational education in Sri Lanka. In students' perspective it affects the problem-solving ability, critical thinking, social interactions and self-management skills development. From the teachers' perspective it can be concluded that CeL affects the flexibility techniques of delivering process, in motivating students and students' performance evaluation. Therefore it can be stated that CeL will positively effect on development of TVET sector in Sri Lanka. When considering the challenges in engaging in collaborative e-learning, it was identified that lack of ICT infrastructure, lack of convenient accessibility to the internet connections and, lack of awareness on collaborative e-learning as major challenges for the effectiveness of collaborative e learning. Similarly, lack of administrative support in obtaining funds for collaborative e-learning applications remains a challenge for both the students and lecturers in e learning. It was also identified that the reluctance of some lecturers to adapt to the online teaching methods as another challenge for collaborative e learning due to the perception on this as an additional workload that need to be undertaken instead of following the traditional methods. Apart from the above findings, it is noteworthy to mention that, the instructor's or lecturers' physical engagement with the students is important in vocational education which enables the hands-on experiences for the respective disciplines emphasizing the challenges of teaching and e learning in vocational education. However, the present study has identified that sustainable approaches like empowering the students and lecturers with continuous enhancement of ICT literacy, knowledge, attitudes and skills towards collaborative e-learning by introducing them to the available and upcoming technological advancements which could be utilized as a way forward to overcome the challenges of working in a highly digitized context. Furthermore, the present study suggests that the government and respective institutional and administrative bodies should contribute for collaborative e-learning for both the lecturers and students by fulfilling the existing gaps with short term and long-term plans since this concept is shaping the current education sector with advanced and continuously changing technology.

### REFERENCES

- Ahmadi, D., & Reza, M. (2018). The use of technology in English language learning: A literature review. *International Journal of Research in English Education*, 3(2), 115-125.
- Andersson, A., 2008. Seven major challenges for e-learning in developing countries: Case study eBIT, Sri Lanka. *International journal of education and development using ICT*, 4(3), pp.45-62.

- Arachchi, S.M., Siriwardena, M., Madanayake, R. and Dias, K., 2010, September. Identification of learning styles and learning domains in Sri Lanka in the development of e-learning content. In *2010 International Conference on Advances in ICT for Emerging Regions (ICTer)* (pp. 50-55). IEEE.
- Basu, C.K., 1997. Challenges of Current Social, Economical and Technological Developments and Need for Reforms/Renovations in Training of Teachers in Technical-Vocational Education. A Discussion Paper.
- Beatty, B. and Ulasewicz, C., 2006. Faculty perspectives on moving from Blackboard to the Moodle learning management system. *TechTrends*, 50(4), pp.36-45.
- Belaya, V., 2018. The Use of e-Learning in Vocational Education and Training (VET): Systematization of Existing Theoretical Approaches. *Journal of Education and Learning*, 7(5), pp.92-101.
- Ben, C.B. and Ashang, M.U., 2013. The role of ICT in skilled manpower development through vocational technical education among higher institutions in Cross River State, Nigeria. *International Journal of Vocational and Technical Education*, 5(5), pp.92-99.
- Browne, C.J., 2019. Assessing the engagement rates and satisfaction levels of various clinical health science student sub-groups using supplementary eLearning resources in an introductory anatomy and physiology unit. *Health Education*.
- Carroll, L.S.L., 2017. A comprehensive definition of technology from an ethological perspective. *Social Sciences*, 6(4), p.126.
- Cheng, I.H., 2010. Case studies of integrated pedagogy in vocational education: A three-tier approach to empowering vulnerable youth in urban Cambodia. *International Journal of Educational Development*, 30(4), pp.438-446.
- Coccia, M., 2019. A new concept of technology with systemic-purposeful perspective: theory, examples and empirical application. *arXiv preprint arXiv:1909.05689*.
- Gamage, D. and Fernando, S., 2012. Engaging interactivity in eLearning: Review of practices and challenges in Sri Lanka.
- Gunawardana, K., 2005, August. An Empirical Study of potential challenges and Benefits of Implementing E-learning in Sri Lanka. In *Special Issue of the International Journal of The Computer, the Internet and Management (2005), Proceedings of the Second International Conference on eLearning for Knowledge-Based Society*.
- Hayashi, R., Garcia, M., Maddawin, A. and Hewagamage, K. P., 2020. *Online Learning in Sri Lanka's Higher Education Institutions during the COVID-19 Pandemic*. Asian Development Bank.
- Isman, A., 2012. Technology and Technique: An Educational Perspective. *Turkish Online Journal of Educational Technology-TOJET*, 11(2), pp.207-213.
- Jayalath, J. and Esichaikul, V., 2020. Gamification to enhance motivation and engagement in blended eLearning for technical and vocational education and training. *Technology, Knowledge and Learning*, pp.1-28.
- Kanaganayagam, I. and Fernando, S., 2013. A Framework to analyze the effectiveness of collaborative e-Learning (CeL) in Sri Lankan University Education. In *National Engineering Conference 2013, 19th ERU Symposium* (pp.1-8).
- King, K., & Palmer, R. (2006). Skills development and poverty reduction: the state of the art. *Postbasic education and training working paper*, 7.
- Kuruppu, G. and Halwatura, R.U., 2013, December. Effectiveness of moodle application on technical tertiary education in Sri Lanka. In *2013 IEEE International Conference in MOOC, Innovation and Technology in Education (MITE)* (pp. 362-365). IEEE.
- Lister, M., 2015. Gamification: The effect on student motivation and performance at the post-secondary level. *Issues and Trends in Educational Technology*, 3(2).
- Maričić, S., Haber, I.M., Radolović, D. and Veljović, I., 2019. The Emerging Role of New Technologies in Vocational Education. *Romania*.
- Marikar, F.M. and Jayarathne, N., 2016. Effectiveness of Moodle in education system in Sri Lankan University. *International Journal of Modern Education and Computer Science*, 8(2), p.54.
- Maurer, M., 2012. Structural elaboration of technical and vocational education and training systems in developing countries: the cases of Sri Lanka and Bangladesh. *Comparative education*, 48(4), pp.487-503.

- Mocanu, E.M. and Deaconu, A., 2017. The Use of Information and Communication Technology (ICT) as a Teaching Method in Vocational Education and Training in Tourism. *Acta Didactica Napocensia*, 10(3), pp.19-34.
- Pal, S.K. and Sonker, B.P., 2013. Impact of ICT on Libraries: A Paradigm Change to Librarianship. *Application of ICT in the Libraries*. Arthava Publication.
- Ray, W. and Shu-Li, H., 2010. Assessment on effectiveness of e-learning in uncertainty. In *2010 IEEE International Conference on Advanced Management Science (ICAMS 2010)*.
- Shdaifat, S.A.K., Shdaifat, N.A. and Khateeb, L.A., 2020. The Reality of Using E-Learning Applications in Vocational Education Courses during COVID 19 Crisis from the Vocational Education Teachers' Perceptive in Jordan. *International Education Studies*, 13(10), pp.105-112.
- Słowikowski, M., Pilat, Z., Smater, M. and Zieliński, J., 2018, October. Collaborative learning environment in vocational education. In *AIP Conference Proceedings* (Vol. 2029, No. 1, p. 020070). AIP Publishing LLC.
- Sulaiman, N.L., Salleh, K.M., Mohamad, M.M. and Sern, L.C., 2015. Technical and vocational education in Malaysia: policy, leadership, and professional growth on Malaysia women. *Asian Social Science*, 11(24), p.153.
- Toner, P., 2010. Innovation and vocational education. *The economic and labour relations review*, 21(2), pp.75-98.
- Wagiran, P., Pa1rdjono, P., Suyanto, W. and Sofyan, H., 2017, September. Vocational Education Development Framework in 21 st Century. In *1st International Conference on Technology and Vocational Teachers (ICTVT 2017) Vocational* (Vol. 102, No. Ictvt, pp. 395-398).
- Wallenborn, M., 2009. The Impact of Vocational Education on Poverty Reduction, Quality Assurance and Mobility on Regional Labour Markets--Selected EU-Funded Schemes. *European Journal of Vocational Training*, 47(2), pp.151-179.
- Weller, M., 2007. *Virtual learning environments: Using, choosing and developing your VLE*. Routledge.
- Yasak, Z. and Alias, M., 2015. ICT integrations in TVET: Is it up to expectations?. *Procedia-Social and Behavioral Sciences*, 204, pp.88-97.

# Effectiveness of On-the Job-Training in Welding Trade

D.H.U.Eranda<sup>\*1</sup>, P.M.K.Kumarasinghe<sup>2</sup>, K.K.A.S.S.R.Britto<sup>2</sup>

<sup>1</sup>Sri Lanka German Training Institute, Kilinochchi, Sri Lanka

<sup>2</sup>Industrial Engineering Training Institute, Moratuwa, Sri Lanka

## ABSTRACT

*On the Job Training (OJT) has been one of the most important components of vocational education. The goal of this study was to assess OJT opportunities in the welding industry. Data was obtained via questionnaires from TVET trainees conducting OJT at three separate training establishments, including the Chief Mechanical Railway Sub-department (A), the Sri Lankan Air Line Ltd.(B), and the Colombo Dockyard PLC(C). The participants in this study were 176 trainees from three separate training establishments, who were doing welding technology courses. The resulting data was analyzed using Microsoft Excel and descriptive statistics. As per the sample expressed they had the option to cover 71% OJT at establishment C, 66% at establishment B and 40% at establishment A. It has been found that the Manual Metal Arc Welding (MMAW) training offered by all three OJT establishments is satisfactory with just over 60% of trainees expressing satisfaction. To provide proper welding process for OJT, TVET colleges should place a greater emphasis on selecting OJT places that include the aforementioned welding process facilities which are covered in the curricula and competency standards. This could be a result of the fact that many OJT programs, even in other trades, do not cover curricula in depth, but more research is needed to corroborate this.*

**Keywords:** *Manual metal arc welding training, On the Job Training, Technical and Vocational Education and Training programs, Welding Technology Courses.*

## 1. INTRODUCTION

Technical and vocational education contributes significantly to the country's human resource development by generating skilled labor, increasing industrial productivity, and enhancing overall quality of life. Technical and Vocational Education and Training (TVET) has made a significant contribution to developing countries' economic progress by ensuring that appropriate personnel is produced in accordance with the needs of business, society, and the global community as a whole. National Vocational Education and Training aims to provide training that fulfils industry needs, thereby making people employable, as well as to provide introductory training to school leavers and unemployed persons to improve their employment and self-employment chances.

In the TVET sector, On-the-Job Training (OJT) is quite significant. It is a necessary investment for individual productivity growth and, ultimately, for the country's economic prosperity. The advantage of the OJT is that it provides the employee with necessary abilities that enable him or her to be more easily suitable for a certain job. Furthermore, OJT will equip the country to deal with the issues posed by low-skilled and unskilled personnel. Most trainees are employed in a shop or workshop for a period of six months to one year to improve their practical abilities. It also allows them to see directly what “real” job entails in terms of attitudes, client relations, and so on. It can be taught in a variety of contexts, from formal classrooms to informal work shadowing. OJT takes place at the workplace and is supervised by a manager or a more experienced employee. The course instructor is usually a professional trainer (or perhaps an experienced employee) who uses hands-on teaching, which is often supplemented by formal classroom training. OJT is the process of teaching an employee how to perform the essential functions of their work. This training might take the shape of formal or informal instruction. OJT focuses on knowledge and abilities that are directly relevant to employment

---

\* Corresponding Author: E-mail - [Eranda@Slgti.Com](mailto:Eranda@Slgti.Com)

requirements. OJT methods include job instruction techniques, work rotation, coaching, and apprenticeship training. However, OJT is currently a popular training modality.

OJT is instruction given to employees while they are on the job. Employees and the company both gain from this. Employees learn in a real-world setting and acquire experience coping with the duties and obstacles they will face on a regular basis. Furthermore, Mihail (2006) and Nevett (1985) noted that OJT allows for “hands-on” experience similar to that of a real-life situation, with the exception of the guidance and assistance provided throughout the OJT program. OJT serves as a bridge between theory and practice, and between classroom education and real-world experience (Meredith and Burkle, 2008); they provide opportunities for more valuable learning experiences (Hite and Bellizzi, 1986; Karns, 2003; Wasonga and Murphy, 2006; Watson, 1992); and they provide a more valuable learning experience (Hite and Bellizzi, 1986; Karns, 2003; Wasonga and Murphy, 2006; Watson, 1992); increases the program's impact (Thiel and Hartley, 1997); and fosters sentiments of social and personal efficacy (Bernstein, 1997). OJT will provide a fantastic opportunity for trainees to become acquainted with the processes and culture of a new organization. OJT allows students to develop their competency and required abilities (Baharuddin, 2014). OJT, also known as practicality, is crucial for improving knowledge, skills, competence, and efficiency (Yusof and Mohiddin, 2018). OJT is one sort of industrial training that focuses on skill development (Alipour, Salehi and Shahnavaz, 2009). OJT makes use of regular or current workplace tools, machines, documents, equipment, knowledge, and skills to teach employees how to execute their jobs efficiently. It occurred in the normal working environment that an employee encounters on the job (Vasanthi and Basariya, 2019). OJT was established in Sri Lanka to expose Sri Lankan Vocational College students to real-world work situations, conditions, and to improve their work level. The goal of OJT is to provide students with the skills and opportunities they need to get work experience and increase their employability.

OJT has a variety of goals from the perspective of the institution. Quite often, the institution wants to get as much as possible out of the program as the trainees do. The following are some of the institution's expectations for the program: practice in theoretical application, increased job preparedness, and improved career readiness and prospects (Alpert, et.al 2009).

In Sri Lanka, the welding industry is regarded as a key economic sector. Welding is the process of permanently joining two or more materials together, usually metals, by heat or pressure or both. When heated, the material reaches molten state and may be joined together with or without additional filler materials being added. Many different energy sources can be used for welding including gas flames, electric arcs, electric resistance, lasers, electron beams, friction, molten metal baths and ultrasound. Welding includes joining methods as diverse as fusion welding, forge welding, friction welding, braze welding, brazing, soldering and explosion welding. It finds its use in many industries like shipbuilding, automobiles, oil and petroleum (Arora, et.al 2019). This sector will grow even more as the economy develops and current technology improves. Across the country, both government and commercial vocational training organizations provide a variety of welding vocational training courses. And OJT has developed skilled labour and strategic solutions to the problem of unemployment in both the formal and informal sectors. OJT is best for skills development and attitude change. Implementation of OJT which focuses on the transition of students to working life, however with little attention given to the process of evaluating OJT places. This research study, which analyzed and evaluated OJT locations in Sri Lanka's welding industry, will be beneficial in understanding the shortcomings of the OJT process and then suggesting some alternatives. Organizations today hold various job-training courses to help employees gain new knowledge and technology, as well as to construct a culture and increase employee performance. As a result, assessing the performance of OJT establishments and their impact on OJT is critical. Because no previous research has been conducted to evaluate OJT locations, Sri Lanka German Training Institute's Industrial Training division and National Apprentice and Industrial Training Authority's Industrial Engineering Training Institute have chosen to undertake a survey to determine the quality and effectiveness of OJT in the welding profession. Welding has become a necessary

component of daily life as a result of increased urbanization and industrialization. It is a very common operation in many industries and workplaces. Welders are one of the most undervalued groups of workers, and they face a variety of work-related issues, including environmental risks and poor safety in most welding workshops. Poor working environment, unavailability of standardized tools and equipment, inadequate premises, unsatisfactory welfare facilities, as well as practically non-existent occupational health services are causing large human and material losses, which burden the productivity of national economies. As a result, this study and its conclusions will be critical in determining the current state of OJT quality. The findings of this study will aid in the development of policies and strategies to solve the flaws in welding OJT.

## **2. RESEARCH OBJECTIVES**

The objectives of the present study are

- To determine the perception of welding students on the effectiveness of the OJT program
- To identify the deficiencies associated with the work environment of OJT places in the trade of welding

## **3. RESEARCH METHODOLOGY**

The research design for this study uses a survey that was carried out qualitatively through questionnaires among welding OJT trainees and OJT establishments. The instrument developed for this research is a questionnaire as a primary data collection source, which was divided in to two parts. Questionnaires are superbly suited for researcher to know the independent thoughts of each individual in a group and examining potential issues. Questionnaire was given to achieve research goals and objectives.

### **3.1 Population, Sample and Data Collection**

Participants included students completing their OJT at three different training establishments as well as instructors at OJT locations were the target population., specifically, the Chief Mechanical Railway Sub-Department (A), Sri Lanka Air Line Limited (B), and Colombo Dockyard PLC (C). Data was collected by inspectors under the supervision of research team. The target group consisted of 176 trainees who were undertaking OJT at these three OJT locations and were chosen at random. Furthermore, this study used purposive sampling technique. Purposive sampling is a non-probability sampling that allows researchers to select subjects for the study and the expectation from each participant is that they will provide information which area unique and valuable for the research (Suen et al., 2014). Sample of 27 trainees randomly selected from establishment A. A random sample of 21 trainees were selected from the establishment B and 128 sample trainees were randomly selected out of 175 population from establishment C.

### **3.2 Tools**

The questionnaire was divided in to two parts: the first portion contained topics relating to welding competency, such as the welding process, types of metal used, provision of equipment and tools, and safety and health issues while the second section of the questionnaire included questions about the training facilities. The questionnaire consisted of closed-ended questions with clear and smooth moving sequence, and responses rated on a five-point Likert scale ranging from 1 to 5, with 1 indicating not at all, 2 indicating not satisfactory, 3 indicating satisfactory, 4 indicating good, and 5 indicating very good.

### **3.3 Data Analysis**

Data collected from the questionnaire was tabulated in to a excel table and presented using bar graphs and histogram statistical charts.

#### 4. RESULTS

##### 4.1 Welding OJT at Establishment A

This analysis took into account the welding process, manual metal arc welding training, opportunities provided by the industry, and the capacity to finish a successful training term. Figure 1 shows that 66 % (18 students) of trainees gave good comments on the industry's availability of opportunity to consistently enhance their abilities during their OJT.



Figure 1: Provision of Opportunity by Establishment A

Furthermore, 37 % (10 students) believed that they were able to complete a satisfactory training term and that the establishment is acceptable for future apprentices, as shown in Figure 2.

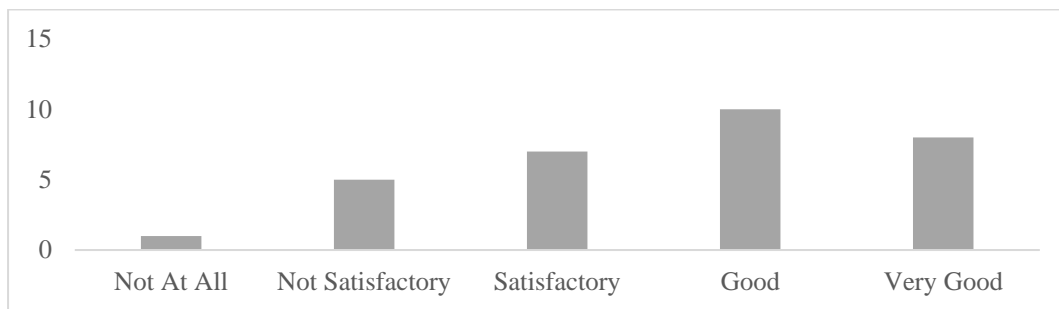

Figure 2: Ability to Complete Satisfactory Training Period at Establishment A

Figure 3 shows that 88.8% (24 students) gave great responses to manual metal arc welding instruction, while 96 % (26 students) gave unsatisfactory feedback to Tungsten inert arc welding training. Figure 4 shows that 70% (19 students) of the pupils were dissatisfied with the welding process training provided.



Figure 3: Manual Metal Arc Welding Training Given by Establishment A

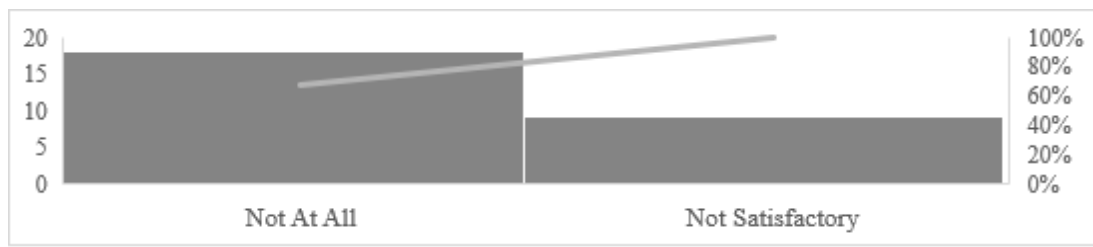

Figure 4: Welding Process Training Given by Establishment A

#### 4.2 Welding OJT at Establishment B

Apart from the other two aspects of welding skill and capacity to complete a successful training period that were used in the previous study, this study additionally considered the provision of equipment and tools.



Figure 5: Provision of Equipment and Tools by given by Establishment B

Figure 5 shows the 28 % (6 pupils) student good response. Figure 6 demonstrates that almost 38% (8 students) of the trainees had a good training experience.

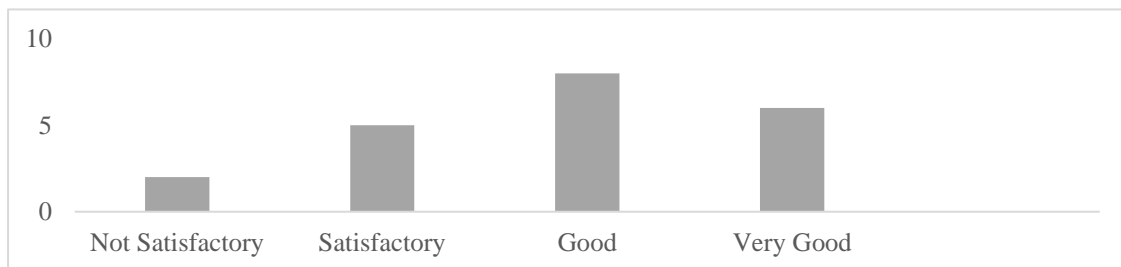

Figure 6: Ability to Complete Successful Training Period at Establishment B

Figure 7 demonstrates that the provided manual metal gas welding instruction had a very good response from just over 23% of the participants (05 pupils). According to the Figure 8, the majority of pupils had an unfavorable view of welding process education, according to the findings. 28.5 % of students (6 students) were absolutely unsatisfied, 52.3 % (11 students) were dissatisfied, and 19 % (4 students) agreed that the student received adequate demonstration, explanation, and assistance during OJT.





Figure 7: Manual Metal Arc Welding Training Given by Establishment B

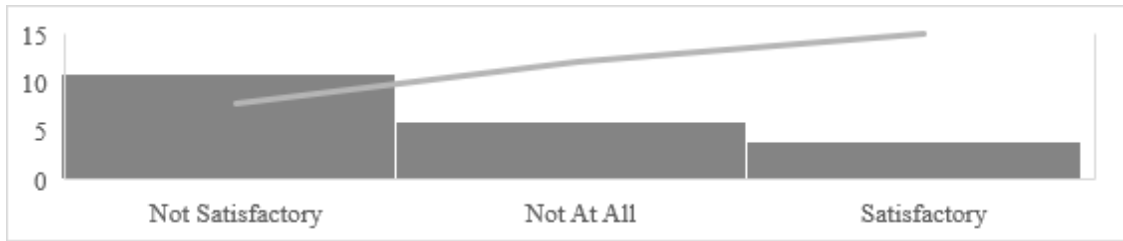

Figure 8: Welding Process Training Given by Establishment B

### 4.3 Welding OJT at Establishment C

The same variables were used to evaluate OJT at establishment C as they were for establishment B. Figure 9 shows that about 79 % (102 students) of trainees gave very favorable feedback on the provision of equipment and materials during the training period.

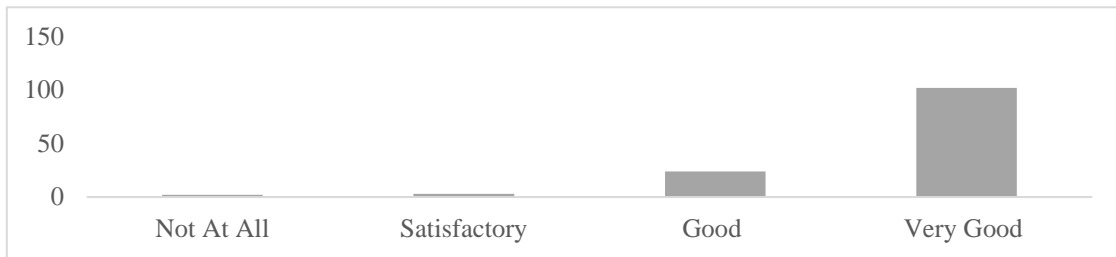

Figure 9: Provision of Equipment and Tools at Establishment C

As shown in Figure10, about 71% (91 students) agreed that they were able to complete a very good training period due to the availability of equipment and tools in a safe working environment. Figure 11 demonstrates that the offered manual metal arc welding received very positive response, with slightly over 63 % (83 pupils) giving it a thumbs up. Figure 12 shows that the establishment C is the best of the three OJT places, with nearly 33 % (43 students) expressing satisfaction with the welding process instruction.

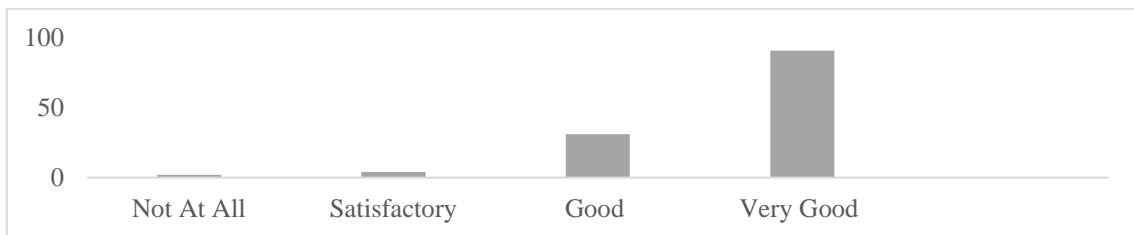

Figure 10: Ability to Complete Successful Training at Establishment C

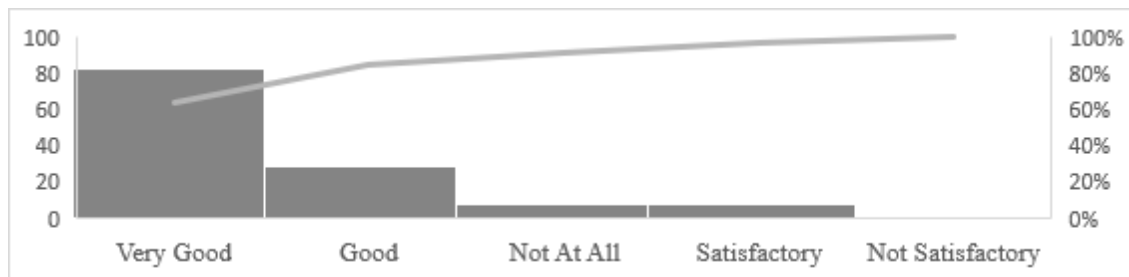

Figure 11: Manual Metal Arc Welding Training given by Establishment C

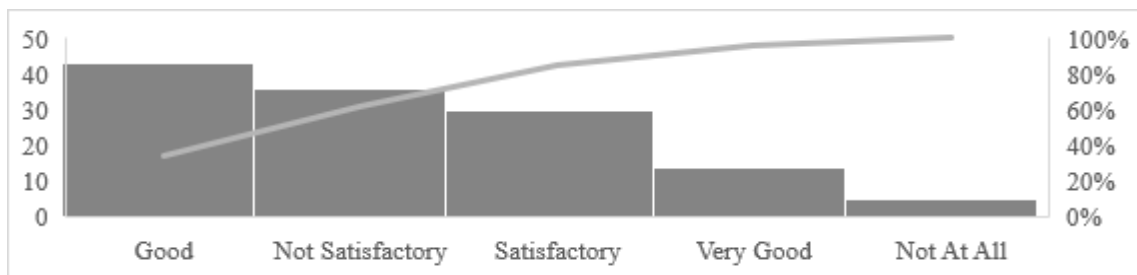

Figure 12: Welding Process Training Given by Establishment C

## 5. CONCLUSION

OJT is being introduced to empower competency and improve students' workability. Therefore, OJT places assessment is vital to ensure the effectiveness of OJT in Sri Lankan Technical college welding courses. It is evident that welding OJT plays a pivotal role in providing TVET students with real life learning, but it is not being properly executed in Sri Lanka due to various reasons. Non availability of modern welding process is the key concern identified from this study. According to the sample, trainees stated that they were able to cover 71% of the OJT at establishment C, 66% at establishment B and 40% at establishment A. According to the data analysis, it has been found that Tungsten inert arc welding (TIA), Metal Inert gas welding (MIA), Metal active gas welding (MAG) and flux cored arc welding (FCAW) trainings are not catered in a satisfactory level by all three OJT establishments. However, we found that that the manual metal arc welding training provided by all three OJT establishments is in satisfactory level in contrary to Tungsten inert arc welding (TIA), Metal Inert gas welding (MIA), Metal active gas welding (MAG) and Flux cored arc welding (FCAW). The most common, reliable and inexpensive welding process is the shielded arc welding process, also called the manual arc welding process (Arora et al, 2019). According to the findings, it is evident that all three OJT establishments provide satisfactory Manual Metal Arc Welding training with over 75% trainee satisfactory rate. In order to provide proper welding OJT, TVET colleges should pay more attention to selecting OJT establishments that offer the above-mentioned welding process facilities, as specified in both curriculum and competency standards. Furthermore, it is recommended to build welding process training institutes with government or donor agency funding to equip high-end tools and equipment to meet the requirements mentioned in national competency standards. Moreover, it is suggested that proper inspection and evaluation should be carried out prior to OJT placement by the trade specialist for the betterment of trainees. This study also advised that academics, industry professionals, and OJT trainees collaborate to develop a credible assessment rubric to analyze the efficiency of OJT places in order to assure the quality of the OJT process.

## REFERENCES

Alipour, M., Salehi, M., & Shahnava, A., 2009. A Study on the Job Training Effectiveness: Empirical Evidence of Iran. *International Journal of Business and Management* 4(11):63-68.

- Alpert, F., Heaney, J.G. and Kuhn, K.A.L., 2009. Internships in marketing: Goals, structures and assessment—Student, company and academic perspectives. *Australasian Marketing Journal (AMJ)*, 17(1), pp.36-45.
- Arora, H., Singh, R. and Brar, G.S., 2019. Thermal and structural modelling of arc welding processes: a literature review. *Measurement and Control*, 52(7-8), pp.955-969.
- Baharuddin, A., 2014. *Amalan penyeliaan pensyarah pembimbing terhadap pelaksanaan latihan industri di Politeknik Sultan Haji Ahamad Shah Kuantan, Pahang* (Doctoral dissertation, Universiti Tun Hussein Onn Malaysia).
- Beinstein, J., 1976. Urban field education: An opportunity structure for enhancing students' personal and social efficacy. *Human Relations*, 29(7), pp.677-685.
- Hite, R. and Bellizzi, J., 1986. Student expectations regarding collegiate internship programs in marketing. *Journal of Marketing Education*, 8(3), pp.41-49.
- Jayathilake, P.C.P., Bandara, H.G.K.N., Nanayakkara, P., 2014. *Study on effectiveness of OJT (special emphasis of Automobile sector) in Colombo District*. Thesis (1-8). Tertiary and Vocational Education Commission
- Karns, G.L., 2005. An update of marketing student perceptions of learning activities: Structure, preferences, and effectiveness. *Journal of marketing Education*, 27(2), pp.163-171.
- Kumarasinghe, P., Britto, K.K.A.S.R., Eranda, D.H.U., 2017. Evaluation of OJT places in an exemplary trade (welding). *TVET research convention*, Colombo 10 August 2017, 12-13
- Meredith, S., Burkle, M., 2008. *Building bridges between university and industry: theory and practice*. *Education and Training*, 50 (3), pp. 199–215.
- Mihail, D.M., 2006. Internships at Greek universities: an exploratory study. *Journal of Workplace Learning* 18 (1/2), pp. 28–41.
- MOE. 2014. *Garis Panduan On Job Training (OJT)*. Putrajaya: Bahagian Pendidikan Teknik dan Vokasional, Kementerian Pendidikan Malaysia.
- Yusof, M.M. and Mohiddin, N.H., 2018. Student Reflection on The Effectiveness of Industrial Training Courses: Study Case of Polytechnic Muadzam Shah Students. *Malaysian Online Journal of Education*, 2(2), pp.46-54.
- Nevett, T., 1985. Work experience: The essential ingredient in British programs. *Journal of Marketing Education* 7 (1), pp. 13– 18.
- Suen, L. J., Huang, H. M., & Lee, H. H., 2014. A comparison of convenience sampling and purposive sampling. *Journal of Nursing*, 61(3) ,pp. 105-111.
- Thiel, G.R., Hartley, N.T., 1997. Cooperative education: a natural synergy between business and academia. *S.A.M. Advanced Management Journal*, 62 (3), pp. 19–24.
- Thomas, A., Agarwal., 2019. A study of on-the-job training (OJT) in vocational higher secondary schools in Kerala. *International Journal of Research and Analytical Reviews (IJRAR)*, 6(2), pp. 39-45
- Vasanthi, S. & Rabiyyathul Basariya, S., 2019. On The Job Training Implementation and Its Benefits. *International Journal of Research and Analytical Reviews (IJRAR)*, 6(1), pp. 210-215.
- Wasonga, T.A., Murphy, J.F., 2006. Learning from tacit knowledge: the impact of the internship. *The International Journal of Educational Management*, 20 (2), pp. 153–163.
- Watson, K.W., 1992. An integration of values: Teaching the internship course in a liberal arts environment. *Communication Education*, 41(4), pp.429-439.

# Effects of Students' Attitude towards Online Learning in Covid-19 Pandemic with Reference to Management Undergraduates

Indrachapa Gunasekara, Jayathree Herath, Uruthiran Sivachelvy\*

Department of Management Studies, University of Vocational Technology, Sri Lanka

## ABSTRACT

*This study was aimed at investigating the effects of students' attitudes towards online learning during the Covid19 Pandemic and focused on students in the University of Vocational Technology (UoVT). The study reveals insights on students' attitudes towards online learning during the Covid19 pandemic with the objectives intended on giving an understanding of how students' attitude towards online learning depends on the online learning experience. The study exerted a quantitative approach with descriptive statistics and regression analysis utilizing Management undergraduates in the University of Vocational Technology as respondents. The results of the study denote that the independent variables correlate with the depicted dependent variable, demonstrating that the model is statistically significant. The outcome derived from the study was that the students' experience of their attitude towards online learning at the UoVT is favorable in the essential education and environment experience and technological availability and accessibility, though there is a refusal toward the psychological and emotional attitudes of the students towards online learning. This study emphasizes its importance in serving as an interpreter of prospective students' attitudes toward e-learning and evidence for educationalists, investigators, policymakers, academics, decision-makers, stakeholders, or anybody interested in the advancement of online learning. Future research in other disciplines as indicated by the author.*

**Keywords:** Attitude, Covid 19, Experience, Online learning.

## 1. INTRODUCTION

The booming hindrance of Covid19 pandemic in the world distracts the lives of people and all sectors of the world with a hangover that makes them susceptible to heights and slopes against the war or facing the crisis and issues at Covid 19 pandemic at the moment. Although it started as a health crisis, today it has devastated all countries each and every right and every single freedom of people with fewer desires and tentative procedures with more alternatives and adaptations to the crisis creating diverse fields to rise back through the pandemic in the world.

The adoption is more vigilant in the preservation of education sectors in countries and is the same for Sri Lanka as a country that has been severely affected by the pandemic for more than a year in advance. It is reported that 80% of the global student population has been affected by the crisis (UNESCO, 2020). Sri Lanka struggles in planning education rights since the physical closing down impacts massively on thousands of students' hopes to flourish in education within the exact range of years that they need to seek it without any justifiable answer for them. It is one year to the Covid 19 epidemic, and more than half of the world's students are still affected by partial or complete school closures and as a result of the health crisis, more than 100 million children will fall below the minimum reading level (UNESCO, 2021).

The country struggles in reaching educational desires, unbending to balance the paradigm between life preservation and economic preservation. It was important to rigid the precautions altered to maintain the well-preserved educational prevalence in the country as it was essential to enable measures by the government and all other diverse educational sectors to collaborate together for electronic learning as a mechanism for online learning that guides them to tackle the situation aiming a favorable stage to overcome the barriers at the moment. It is very important to prioritize the recovery of education to avoid a generational catastrophe (UNESCO high-level ministerial meeting in March 2021).

The number of educational institutions collaborating with online learning procedures guided through electronic mediums began to rise dramatically in the country, with familiarity to the surge of all

---

\* Corresponding Author: Email - [uchelvy@yahoo.com](mailto:uchelvy@yahoo.com)

country's rapid expansion in this regard. This occurrence resulted and forced willingly or unwillingly the students and teachers to relocate them from physical context to new online educational systems became a premium option for educationalists to integrate diverse learning approaches as a precaution for educational resilience in the novel pandemic, driving specifically the universities to cater students' needs with an instantaneous learning environment, negotiating in a setting that is discrete from traditional context by accepting unparalleled approaches with diverse strategies making distance education possible at the country.

However, this sudden transmission could have encountered all academics in a state of mind that aligned them in uncertainty, loneliness, and an assurance on their exams, graduations, and even classes and explicitly on practical and extra-curricular activities and approaches that overly impacted their learning career paths. Moreover, most of the research indicates the issues of this massive change in the academic sectors that even predict several misfortunes for children's mental and emotional efficiency thereby, the attitude enhancement or de enhancement is a unique feature that seeks special attention in studies and takes importance and essential awareness for the continuous flow of online learning mechanisms in the sector. Subsequently, with the advent of the Covid 19 pandemic, students all over the world faced many challenges in relation to converting their learning into online learning. The online learning were either full-time or hybrid models with blended methods (Mehrotra *et al.*, 2021).

Researchers have also found that these social exclusion activities greatly affect the mental, physical and emotional health of adolescents. (Aristovnik *et al.*, 2016). "We consider it is essential to assess the attitude of students towards online learning "(Mehrotra *et al.*, 2021, p.107). This has led the academic and universities to evaluate the efficiency of the online learning process while deriving challenges and opportunities compared to physical learning environments. This study will focus on initiatives in the University of Vocational Technology in adapting the new learning platforms by assessing students' attitudes toward their initial engrossment with online learning during the quarantine period. Specifically, capabilities and issues are illustrated, guiding potential outcomes that could be generated from online learning withhold to the future prospects.

This study is devoted to the essential requirement of assessing the students' experience and attitudes toward the novel context of e-learning defined as an arrangement that utilizes internet technology to distribute information to students with relation to computer interfaces (Al-Adwan & Smedley, 2013). In online learning, the viewpoints of students on the teaching approach greatly matter in their interest in learning and continuous participation in the classes (Yassine, 2021).

Although many studies have been directed to examine students' insights on the presence of distance e-learning in their learning platforms, diverse studies depict diverse results based on each range of their unique characters specific to different contexts and different countries. This varied experience in varied platforms enhanced this study to assess more on a different context with relation to an own teaching platform reference to the University of Vocational Technology in Sri Lanka in viewing and analyzing the real perception the undergraduate generate on the online learning addicted in the university which is also a fact that is widely implemented in all universities in the country. So, this study is intended to give an insight into how students' attitude towards online learning depends on the online learning experience of students perceived at the University of Vocational Technology in Sri Lanka and to derive its real outcomes at this stage.

## **2. LITERATURE REVIEW**

### **2.1 Covid 19 Pandemic Influence on Academic Sector**

The Covid 19 pandemic has interrupted the casual life patterns of people attacking each sector. From the initial point of the spread of the virus all over the country, Sri Lanka also disrupted and started to become weaker to a certain point with regenerations until to date and still facing the threat in a mysterious way. The Higher Education field is a specific sector attacked severely by the pandemic since its beginning and fully impacted the whole system. Specifically, to Sri Lanka that converted entire arrangements in diverse paths bent with online learning mechanisms that were capable for the sake of online platforms with unexpected editions and revisions occurred in methodology and context in bringing education, while encountering the challenges of Covid 19 Pandemic globally (Chandrasinghe

*et al.*, 2020; Hayashi *et al.*, 2020; Adarkwah, 2020; Marinoni *et al.*, 2020). Researchers have discovered the sudden critical importance of efficient academic performance that needs alterations and changes in their education platforms to cater educational needs of students to draw back from the crisis and preserve the durability of the educational system in the country.

## **2.2 Students' Attitude during COVID-19 towards Learning**

The attitude of students towards learning during the Covid pandemic depicts various results in diverse contexts according to different research conducted in comparative environments. Most researchers exhibit positive attitudes toward learning during COVID-19 and it shows a sudden movement of students towards adaptations in online learning specifically in higher education. (Toquero, 2020; García *et al.*, 2020). Several researchers predicted that the Positive attitudes generated towards online learning throughout the pandemic among university students initially motivated them with self-motivated learning methods that were conducted in online formats. Also, the studies highlighted that the students' rapid adaptation to online learning was amplified due to the urgent necessity of students completing their studies with less time duration. (Ismaili, 2021; Marinoni *et al.*, 2020).

Research conducted in Malaysia highlighted a sudden decline of motivation of students towards learning in the pandemic which again reemerged with the influence of online learning methods with travel barriers. (Kamal & Shaipullah, 2020). Further, the study specified the difficulty of adapting to the online environment by students. Also, Kamal & Shaipullah, (2020) reveal that the students who prefer face-to-face learning are extra probable to show lower attachment to the online learning platforms while specifying the importance of researching in this regard.

The significance of distance online learning platforms dates back to the 1990s and the sudden outbreak of coronavirus flourished the use of online learning throughout the world than ever before while equipped with modern technology and upgrades in the world. Accordingly, online learning has a potential need for more planning that requires more attention and priority (Reynolds *et al.*, 2007). "Online learning presents both opportunities and barriers for educational institutions" (Reynolds *et al.*, 2007). Moreover, most of the current studies have focused on online learning in diverse contexts, depriving the impact and its importance. Also, most studies predict that online learning and physical classroom learning do not show much difference in student involvement in the studies, and attitudes raised are the same in each context. Roddy *et al.*, (2017) depicted the same fact by comparing them equally among physical and virtual contexts and concluded that the attitude on online learning can be the same or different as normal classrooms with overall satisfaction ratings and context.

## **2.3 Exposure to Technological Availability**

The exposure the students generate on online platforms is important since the students' degree of attention in this and the accessibility of Information and Communication Technology (ICT) is substantial that directly impacts the attitudes and readiness of students to be comfortable in e-learning (Klimov, 2012). "Significant developments in Education Mixed learning of traditional and online education has been taken on over the past decade as a substitute approach to teaching and has confirmed to be an appropriate option for educational systems" (Hubackova & Semradova, 2016). The University system itself began a rapid adaptation to online platforms to enable online learning mechanisms since the spread of coronavirus and that drives the entire higher education to hold at the pandemic and continue studies. The preserved technology made it possible and necessary to provide online learning as the only preferable option to retain education while moving forward.

## **2.4 Learning Model**

Diverse learning models are developed in the recent world to cease the learning environment and experience of the students. Walberg and Moos's learning model is such an approach that figured the base for research studies investigate human-environmental connections and the implication of the physical and social setting, on the learning experience. It specified the unique challenges derived by students in learning environments while creating strategies for a comfortable learning environment required for students (Zandvliet, 2004). Walberg (1980), predicts the validity of a classroom environment on students' educational sustainability while stating the fact that novel environments

generate novel attitudes and challenges to the students and teacher in any context of learning and conditions.

Therefore, it is essential to analyze the involvement of distance e-learning in the context of technological, environmental and emotional design experience and the attitude adaptations of students in this regard. “Assimilating e-learning into the students’ learning atmosphere involves awareness of the connection between students, teachers and technologies within a design context” (Ellis *et al.*, 2009). Moreover, Hickcox (1995) defines learning as a relatively permanent change in an attitude or behavior that occurs as a result of repeated experience and illustrates the importance of learning styles more importantly derives a categorization model in which the learning instruments were categorized into the main sectors as, Educational and environmental learning partialities. Data processing learning partialities and Individual learning partialities that specify the students’ attitude towards online learning in the above study.

### 3. RESEARCH GAP

Even though the higher education and the university systems adapt initiatives to cater to students’ education durability through online platforms, the lack of experience and practice in the distance online learning environment raises challenges and sectors to be reviewed and analyzed. “By transforming the traditional classroom into an online learning environment, getting student feedback in all educational activities has become integrated” (Sundarasan & Chinna, 2020).

In the Sri Lankan context, online teaching preferred to be challenging with technological and environmental developments and accessibilities and this novel experience generated gaps between students’ attitudes towards the experience they achieve in the online learning environment. The purpose of the study is to examine students’ exposure and attitudes in general towards the fully online learning experience in epidemiological situations by referring to university education.

### 4. CONCEPTUAL FRAMEWORK

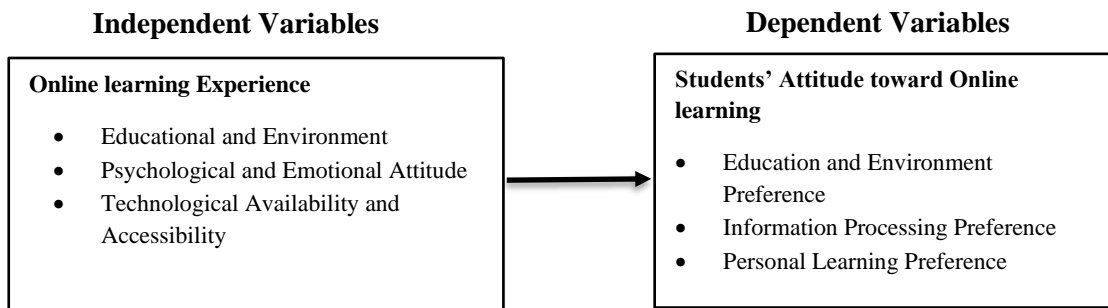

Figure 1: Conceptual Framework of the Study

Based on the literature review conceptual framework is developed as indicated in Figure 1. According to Figure 1, online learning Experience (Educational and Environment, Psychological and Emotional Attitude and Technological Availability and Accessibility) is an independent variable and Students Attitude toward Online learning (Education and Environment Preference, Information Processing Preference and Personal Learning Preference) is a dependent variable for this study.

### 5. METHODOLOGY

The study utilized a sample of 160 students from the University of Vocational Technology, Ratmalana, Sri Lanka. Among a population that consisted of diverse undergraduates, the management undergraduates were considered. Data were collected with a questionnaire with demographic data and five-point rating scale questions created through Google Forms which mainly illustrate the online learning experience during the quarantine at the university.

The material focuses on Technological availability and accessibility, Educational and environmental conditions and Psychological and emotional attitudes toward e-learning experience while utilizing the categorization model of Hickcox (1995) to measure the students’ attitudes toward the online learning

experience. The data were analyzed with a statistical package for the social sciences that conducted a Quantitative analysis and descriptive statistics for the data review and interpretations describing data outcomes in the study.

## 6. DATA PRESENTATION AND DATA ANALYSIS

The demographic analysis of the study pointed to variations between gender, age and degree programmes involved at the university by students. In approaching that, the total respondents were 46% from males and 54 % from females among a total of 160 respondents. In signifying the age categorization, the majority belongs to the age group “above 24” and only 6% of respondents represent the age group “below 20” while 36% range between the “20 -24” age category. The sample consists basically of two-degree programmes as 9% from Hotel Management and 90% from Industrial Management Technology.

The initial analysis on device utilization in online learning implied a division between the use of one's own smartphone (52%) and some other smartphone (21%) while also making a gap between the use of laptops and desktops (20%), showing the disparity of technological usage facilities of students.

Table 1: Reliability Statistics

Cronbach's Alpha	N of Items
0.943	32

Cronbach's alpha coefficient was utilized to examine the internal reliability of the questionnaire. The internal reliability for 32 items was 0.943, (> 0.6), suggesting relatively greater internal consistency which is considered “acceptable” to run the model in further analysis.

In determining the most influential variable that would affect the students' attitude towards online learning, student experience determinants were analyzed with a regression analysis.

Table 2: ANOVA

Model		Sum of Squares	Df	Mean Square	F	Sgn
1	Regression	30.010	3	12.003	104.365	.000 <sup>b</sup>
	Residual	17.712	154	.115		
	Total	53.723	157			

Table 2, illustrates the overall significant levels between the variables in this analysis. These results outline the point that all independent variables shown here are significantly correlated with the depicted dependent variable since the p-value (0.000) is less than 0.05 and it demonstrates the model is statistically significant.

Table 3: Model Summary of Regression Analysis

Model	R	R Square	Adjusted R Square	Std. Error of the Estimate
1	.819 <sup>a</sup>	.670	.664	.339

a. Predictors: (Constant), TAA, EE, PEA

Here, as demonstrated in Table 3, multiple correlations (R) are 0.819 which indicates that independent variables are correlated with the dependent variable (Students' attitude toward online learning), which is described based on Education and Environment Preference, Information Processing Preference, Information Processing Preference and personal learning preference that would generate a moderate linear relationship within the model between the two main variables. The coefficient of determination (R square) is 0.670. That denoted 67% of the dependent variable (Students' attitude toward online learning) is covered by the regression model. The adjusted R square is 0.664 and it was lower than the R square value which states that the shown regression model is well fitted.



Table 4: Coefficients

Model		Unstandardized Coefficients		Standardized	t	Sig.
		B	Std. Error	Coefficients Beta		
1	(Constant)	.841	.143		5.861	.000
	EE	.229	.060	.304	3.794	.000
	PEA	-.005	.070	-.006	-.066	.947
	TAA	.517	.070	.572	7.335	.000

The findings derive the multiple regression equation as,

$$Y = 0.841 + 0.229 b_1 - 0.005b_2 + 0.517b_3 + \varepsilon \quad (\text{Eq.: 1})$$

Y = Students' attitude toward online learning

a = Constant level of Students' attitude toward online learning

b<sub>1</sub> = Educational and Environment experience

b<sub>2</sub> = Psychological and Emotional Attitude experience

b<sub>3</sub> = Technological Availability and Accessibility experience

ε = Error term

It is depicted that when all independent variables were held constant, the dependent variable; Students' attitude toward online learning is 0.841. The model implies basically that, among the three main independent variables, Educational and Environment experience (EE) and Technological Availability and Accessibility experience (TAA), generates a positive impact on the attitude of students towards online learning mechanisms at the university, being statistically significant with p-value, 0.000, which is smaller than 0.05. Comparatively, it exhibits that there is an impact of the educational environment and technological accessibility and availability to foster the attitude of students towards accepting online learning mechanisms for their studies.

Contrastively, the Psychological and Emotional experience (PEA) does not create a positive influence on students' attitudes and the students do not reinforce to utilize online learning with a better psychological and emotional approach, been also technically not statistically important with a p-value is greater than 0.05

Moreover, the results of the study revealed that with referred to all the factors considered, the technological availability and accessibility experience employ a strong influence on the dependent variable of students attitudes which strictly implies the fact that most of all students are favorable to the technological adaptation in online learning movement in the Covid 19 pandemic situation at the current scenario, while also proving that it is emotionally and psychologically a burden in students daily routines that need more attention and willingness of universities that will foster and accept them towards online transmission generating positive influence for their studies future routines at the university.

## 7. DISCUSSION AND CONCLUSION

This study focused on evaluating management students' attitudes towards online learning experience during Covid19. The findings of the study developed in online learning experiences of studies and the relationship between students' experience in their attitude towards online learning tools provided by the university. The researchers have been able to produce the recommendations based on the research findings in order to improve the learning experience for the students who study at the University of Vocational Technology.

Students' experience with online learning during the Covid19 pandemic was evaluated compared to their traditional classroom experience which resulted in several implications that prevented students' engagement with teaching and the teacher. Students displayed rather different prospects and experiences ranging from satisfaction to dissatisfaction with their learning process. The relationship

between the experience and attitude was evaluated based on questions in six major areas. Education environment preference, Information processing preference and personnel learning preference are the three areas of evaluation that cover the students' attitude and the experience were evaluated based on education and environments, the psychological-emotional attitude and technological availability and accessibility of the students.

Referring to the results of the study, the authors identified that new online learning methods and instructions forced on students have provisionally transformed some students' ability to integrate and new normal approach in their thoughtful and adjust themselves to new truths.

The responses were graded as satisfaction in relation to platform availability and accessibility. The students' satisfaction was recorded with the platforms provided by the university and easiness of accessibility. Though there is an insignificant number of dissatisfied students' responded in relation to the platforms. The authors' interpreted the cause of this as the potential difficulty that those students faced while using those platforms. It is acknowledged that most students did not have sufficient training or experience with those platforms. When it comes to the educational and environmental conditions, there is overall satisfaction with class time flexibility. There were several indications that distance learning was more useful in the integration of course materials.

The personal learning preference in students' attitudes compared to the traditional classroom, generally indicated positive attitudes towards the experience. For example, students' expressing that there is no formal classroom environment other than online class applicable to the impartial scale was highly rated as there was a major difference in satisfaction levels to each learning environment. The authors' explanation of this is that those students who reported that online classes were less appealing were not as proficient on online learning platforms. It is notable that, the enormous majority of students fondled that face-to-face real-time interactions are crucial. The authors point to the social significance that is derived in a traditional classroom as an essential factor in student attitudes. Revolving to new environments and developing a "community of practice" model of online interaction with staff and peers appears to take some time.

Finally, the students' experience of their attitude towards online learning at the University of Vocational Technology is favorable though there is a refusal toward the psychological and emotional attitudes of the students towards online learning. The results of this study can be helpful and serve as an analyst of prospective students' attitudes toward e-learning. Educators, researchers, policymakers, scholars, stakeholders and decision-makers who are interested in the development of e-learning can use the study outcomes for policy decisions and actions. The conclusion of the study displays that device usage of the sample indicates a significant difference. Since the research focused only on the degree programmes offered by the Department of Management, there is a possibility for future research in other disciplines.

## REFERENCES

- Marinoni, G., Vant Land, H. and Jensen, T., 2020. The impact of Covid-19 on higher education around the world. *IAU Global Survey Report*.
- Toquero, C.M., 2020. Challenges and opportunities for higher education amid the COVID-19 pandemic: The Philippine context. *Pedagogical Research*, 5(4).
- García-Peñalvo, F.J., Corell, A., Abella-García, V. and Grande, M., 2020. Online assessment in higher education in the time of COVID-19. *Education in the Knowledge Society*, 21.
- Ismaili, Y., 2021. Evaluation of students' attitude toward online learning during the pandemic (Covid-19): a case study of ELTE university. *On the Horizon*.
- Kamal, A.A., Shaipullah, N.M., Truna, L., Sabri, M. and Junaini, S.N., 2020. Transitioning to online learning during COVID-19 Pandemic: Case study of a Pre-University Centre in Malaysia. *International Journal of Advanced Computer Science and Applications*, 11(6).
- Sundarasan, S., Chinna, K., Kamaludin, K., Nurunnabi, M., Baloch, G.M., Khoshaim, H.B., Hossain, S.F.A. and Sukayt, A., 2020. Psychological impact of COVID-19 and lockdown among university

students in Malaysia: implications and policy recommendations. *International journal of environmental research and public health*, 17(17), p.6206.

Reynolds, P.A., Rice, S. and Uddin, M., 2007. Online learning in dentistry: the changes in undergraduate perceptions and attitudes over a four year period. *British dental journal*, 203(7), pp.419-423.

Roddy, C., Amiet, D.L., Chung, J., Holt, C., Shaw, L., McKenzie, S., Garivaldis, F., Lodge, J.M. and Mundy, M.E., 2017, November. Applying best practice online learning, teaching, and support to intensive online environments: an integrative review. In *Frontiers in Education* (Vol. 2, p. 59). Frontiers.

# Factors Affecting Students' Performance in Mathematics: A Case Study based on Secondary Schools in Mawanella, Sri Lanka

M.N Nafra Farwin<sup>1</sup>, Jayalal Wettasinghe<sup>\*2</sup>

<sup>1</sup>Department of Education and Training, University of Vocational Technology, Sri Lanka

<sup>2</sup>Department of Mechanical and Manufacturing Technology, University of Vocational Technology, Sri Lanka

## ABSTRACT

*Mathematics is a great technique to develop logical thinking. Furthermore, mathematical knowledge is essential to comprehend the topics of other educational courses such as science, social studies, and history. Despite the importance of mathematics, many students find it challenging to understand it. This study explores factors leading to low performance in mathematics in secondary schools in the Hemmathagama area of the Mawanella educational zone in Sri Lanka. The sample of the study consisted 158 students from grades 9, 10 and 11 from two secondary schools. The data collection was done by using questionnaires. Data were qualitatively analysed to identify the factors affecting learning Mathematics and what the students expect from Mathematics teachers to improve their knowledge in Mathematics. Then based on the findings, another questionnaire was developed and circulated among a different group of students in order to refine the results further and to validate them. From the descriptive analysis of data, some important factors were identified from the viewpoint of students. Those findings include few factors leading to the low performance in Mathematics and the students' expectations when teaching Mathematics.*

**Keywords:** Learning and Teaching, Low performance, Mathematics.

## 1. BACKGROUND ABOUT MATHEMATICS EDUCATION IN SRI LANKA

Society views mathematics as the basis of scientific and technical knowledge, which is critical to the nation's social and economic growth. Mathematics is also considered a prerequisite for admission to academic programmes in medicine, architecture, and engineering, among others (Mbugua *et al.*, 2012). Understanding other disciplines such as science, technology, and engineering, etc., essentially require Mathematical ability to form new inventive workers in the sciences and technology domains (Mazana, Montero and Casmir, 2020). Further, mathematics plays a critical role in most social sciences, such as business, economics, and management studies (Gitaari *et al.*, 2013). Despite the significance of mathematics, many students find it challenging to grasp the subject (Galadima *et al.*, 2007).

In the Sri Lankan education system, several problems associated with mathematics education at the secondary level were identified. New proposals were put forward in 2003 to improve the quality of mathematics education at the junior secondary level (NEC, 2003).

Today, thinking and non-routine analytical skills are required to identify problems at many jobs. Teaching mathematics focuses on developing a person's analytical and problem-solving skills. The Government of Sri Lanka is taking many steps to improve the knowledge of students. However, nowadays, students' performance in mathematics is relatively low. In the exams, many students fail in mathematics. However, it is observed that the performance of urban students is better than that of rural students.

Table 1 below presents the percentage of failures of mathematics at G.C.E (O/L) examination from 2002 to 2009 while table 2 shows the percentage of failures of mathematics at G.C.E (O/L) examination from 2012 to 2019

---

\* Corresponding Author: E mail - [jayalal@uovt.ac.lk](mailto:jayalal@uovt.ac.lk)

**Table 1: percentage of failures of mathematics at G.C.E (O/L) examination from 2002 to 2009**

Year	2002	2003	2004	2005	2006	2007	2008	2009
<b>Number of students faced for Mathematics</b>	341638	366607	362072	370290	369307	276126	256858	271611
<b>Number of failures</b>	204880	211972	197402	211473	211687	142067	127813	133117
<b>percentage Failure (%)</b>	59.97	57.82	54.52	57.11	57.32	51.45	49.76	49.01

(Source: Results reports of Department of Examinations from 2002 to 2009)

**Table 2: percentage of failures of mathematics at G.C.E (O/L) examination from 2012 to 2019**

Year	2012	2013	2014	2015	2016	2017	2018	2019
<b>Number of students faced for Mathematics</b>	267858	264177	256800	272723	285537	296205	295406	304894
<b>Pass percentage (%)</b>	44.65	57.23	56.70	55.18	62.81	67.24	68.30	71.08
<b>percentage Failure (%)</b>	44.65	42.77	43.30	44.82	37.19	32.76	31.70	28.92

(Source: Results reports of Department of Examinations from 2012 to 2019)

According to the data shown in Table 1 and Table 2, it can be observed that, on average, nearly 45% of the students fail in Mathematics at G.C.E O/L exam and hence the whole exam.

The main objective of this study was to identify the problems that students face in learning mathematics and the factors that are influencing their low performance.

## 1.2 Review of Related Literature

The NEREC (2012) studied variables associated with achievement in mathematics of Grade 4 students in Sri Lanka and discovered that, while mathematical and psychological factors were both related to the achievements in mathematics, the contribution of mathematical factors is high. In NEREC (2012) study, mathematical factors comprised logical thinking ability, computational skills, mathematical language, and mathematical concept. Further, the NEREC (2012) study gave the psychological factors such as attitude towards mathematics, interest in mathematics, and memory. Pupils' experiences within the learning processes and classroom practices are highly significant to their learner identities, expectations, aspirations, and motivations.

The notion of students being at various levels in different subjects is reiterated by Herscovics and Lncnerski (1994). They claim that arithmetic and algebra have a cognitive divide. This gap might be defined as the pupils' incapacity to work with or without the unknown at the same time. According to the authors, a low-attainer lacks the capacity to generalize a skill to a new circumstance or modify a skill to incorporate a new situation without the assistance of a teacher. This is further complicated when considering the mathematics education in Sri Lanka. In Sri Lankan schools, students must learn five strands. These are: numbers and the number system, algebra, shape, space and measurement, handling data and using and applying mathematics to solve problems (NBMS, 2005). Pupils will gain varying degrees of comprehension in various strands and topics within these threads. As the year progresses, most of the Sri Lankan pupils attend different tuition classes and they are learning same topic several times from different teachers. As a result, there is no clear clarification of the characteristics of low-attainers that may be used on all students equally throughout the Sri Lankan school context.

Savas *et al.* (2010) explored the factors effects on student's mathematical achievement in grade 6<sup>th</sup>, 7<sup>th</sup> and 8<sup>th</sup> in secondary schools. Explanatory variables such as school type, family wealth, study time, and students' attitude toward mathematics as well as attendance at private lessons were explored. Explanatory variables such as school type, family wealth, study time, and students' attitude toward mathematics as well as attendance at private tuition classes were explored. The result of study showed that type of school, family income, studying time, and student's attitudes towards mathematics significantly effects on students mathematics achievement. Many learners cited the following issues as causes for low success, according to Gourgey (1992).

- When mistakes are made and you don't know how to fix them, you feel helpless.
- Doubts about one's own intuition.
- Mathematics is highly emotive, producing strong feelings of repulsion and dread of failure.

According to the literature, it is observed that exploring the factors influencing Mathematics education is a significant research area. As a result, the purpose of this study is to investigate the variables that contribute to low mathematics performance in Sri Lankan schools, taking the students from Kegalle District Mawanella Zonal Hemmathagama area senior secondary schools.

## 2. METHODOLOGY

Both qualitative and quantitative techniques were used in this study. The population is Grade 9, 10, and 11 students in Sabaragamuwa province Kegalle district Mawanella educational zone. The sample is grade 9, 10, and 11 students in selected 2 schools in Hemmatagama.

Design of the research and the steps of conducting the research were as follows.

Step	Activity
Step 1	Selecting the students with less than 50 in Mathematics in the last term test marks of Grade 9, 10 and 11
Step 2	Collect data through questionnaire and interview from 102 students in two schools
Step 3	Analyze the data qualitatively
Step 4	Distributing and collecting the questionnaire with identified factors (from steps 2 and 3) among students (Different groups from step 1)
Step 5	Analyzing the data using descriptive statistics

A questionnaire was given to grade 11 (2020, 2021) students in a random sampling method in two schools. The questionnaire was analyzed qualitatively, and its' results were used to design the second questionnaire, which was supposed to be analyzed quantitatively. It is made through a Google form because the schools are closed due to COVID 19. This questionnaire was sent online to grade 9, 10, 11 students.

## 3. DATA ANALYSIS

A qualitative questionnaire was prepared and distributed among the students' sample to get the students' opinions about learning Mathematics and the factors affecting learning Mathematics. Data were collected from 102 respondents' data (2020/2021) in two schools. From the responses received, it is observed that most students are enthusiastic in mathematics, but they do not have proper guidance. So their performance in mathematics is weak. Although students are interested in learning mathematics, they have negative mindset about mathematics, so it is difficult for them to learn.

Key features identified for low involvement in mathematics from the view point of students are teachers, and teaching methods, lack of motivation, students' negative mind-set and family. According to the responses received, some of the factors that the respondents have identified for their low performance in mathematics are as; fear about mathematics, Mathematics is not important for everyday life, lack of motivation about mathematics, negative mind set when learning mathematics, difficulty to remember

mathematics formulas and equations, fast teaching, teaching methods that are not favourable for learning Mathematics

The quantitative techniques were employed to analyze data using SPSS software. A quantitative questionnaire was prepared mainly based on the findings from the first questionnaire. The questionnaire was circulated through a Google form due to the COVID 19 situation of the area concerned. Responses for the Google form was collected by sending it online to grade 9, 10 and 11 students.

It was expected to conduct a descriptive analysis for the data obtained from the second questionnaire. Since the Mean has no meaning for ordinal data (5 points Likert scale used), the results are drawn using the median and percentages.

Table 3 shows the median and percentages for the statements related to the factors affecting the low performance in Mathematics.

Table 3: Median and percentage analysis of data

Statement	Median	percentage analysis for the responses				
		Strongly agree	Agree	Neutral	Disagree	Strongly disagree
<b>I have a fear of mathematics</b>	3		44.6	14.3	32.1	8.9
<b>There is no motivation to learn mathematics</b>	3	3.6	30.4	23.2	35.7	7.1
<b>I think Mathematics is not important for everyday life</b>	4	3.6	12.5	7.1	51.8	25.0
<b>I feel Lazy to learn mathematics</b>	4	1.8	26.8	12.5	41.1	17.9
<b>I cannot remember mathematical formulas</b>	3	3.6	32.1	26.8	28.6	8.9
<b>I have negative mind-set when learning mathematics</b>	4	1.8	26.8	14.3	41.1	14.3
<b>Mathematics not taught in appropriate ways</b>	3	5.4	30.4	17.9	30.4	16.1

The conclusions related to the factors affecting to the low performance are drawn based on the median and percentages analysis shown in Table 4. The decision is taken by considering the median and the percentages together. If the first statement is considered, the median 3 indicates that 50% of the respondents have marked their preferences from strongly agree to the neutral range, and the other 50% have marked for the negative side. The percentages show that 44.6% have agreed to the given statement. So, it is reasonable to consider that the fear for Mathematics is a factor that negatively affects to the performance in Mathematics.

By performing a similar analysis, the factors that students think of as leading to their low performance in Mathematics are;

- I have fear about mathematics
- There is no motivation to learn mathematics
- I cannot remember mathematical formulas
- Mathematics is not taught in the appropriate ways

Table 4 shows the median and percentages for the statements related to factors that are helpful in learning Mathematics and what students expect from Mathematics teachers for improving their performance in Mathematics.

Table 4: Median and percentage analysis of data

Statement	Median	percentage analysis for the responses
-----------	--------	---------------------------------------

		Strongly agree	Agree	Neutral	Disagree	Strongly disagree
<b>Support of Friends and family is important for learning mathematics</b>	2	23.2	42.9	17.9	10.7	5.4
<b>Model papers and past papers are helpful for learning mathematics</b>	2	28.6	51.8	8.9	7.1	3.6
<b>Self-study is necessary for mathematics</b>	2	35.7	48.2	7.1	7.1	1.8
<b>It is desirable for teachers to pay individual attention of students when teaching mathematics</b>	2	26.8	51.8	12.5	7.1	1.8
<b>Additional classes</b>	2	35.7	46.4	10.7	3.6	
<b>Extra explanation</b>	1	50.0	39.3	1.8	5.4	
<b>Kindness</b>	2	30.4	50.4	5.4	1.8	
<b>Give different questions for practice</b>	2	26.8	55.4	3.6	1.8	

The conclusions drawn based on the median and percentages analysis shown in Table 6. The decision is taken by considering the median and the percentages together as in the previous case. The cumulative percentage 66.1% indicates that the favourable responses to the given statement are very high. Since the median is 2 for all the cases and it is 1 for only case, it is obvious that students think that all these factors are favourable for learning Mathematics well. It is also observed that they highly expect more explanations on the subject.

#### 4. CONCLUSION AND RECOMMENDATION

Mathematics is essential for daily life from child to adult. It emphasizes the improvement of a person's analytical and problem-solving abilities. It is obvious that students should learn mathematics. Because it is necessary for many important things, including daily life. It is observed that there are psychological reasons behind low performance in Mathematics, i.e., fear for Mathematics. So, actions should be taken from the primary classes to eliminate that fear from the students, by properly mentoring and giving the necessary motivation to learn Mathematics.

#### REFERENCES

- Galadima, I. and Yusha' U, M.A., 2007. An investigation into Mathematics performance of senior secondary school students in Sokoto State. *Abacus*, 32(1), pp. 24–33.
- Gitaari, E. M. E. et al.. 2013. Factors Contributing to Students Poor Performance in Mathematics in Public Secondary Schools in Tharaka South District , Kenya', 4(7), pp. 93–100.
- Gourgey, A.F., 1992. Tutoring developmental mathematics: Overcoming anxiety and fostering independent learning. *Journal of developmental education*, 15(3), p.10.
- Herscovics, H. and Lincherski, L. (1994) A cognitive gap between arithmetic and algebra, *ESM* 27
- Mazana, M. Y., Montero, C. S. and Casmir, R. O. (2020) 'Assessing Students' Performance in Mathematics in Tanzania: The Teacher's Perspective', *International Electronic Journal of Mathematics Education*, 15(3), p. em0589. doi: 10.29333/iejme/7994.
- Mbugua, Z. et al. (2012) 'Factors Contributing To Students' Poor Performance in Mathematics at Kenya Certificate of Secondary Education in Kenya: A Case of Baringo County, Kenya', *Aijcnet.Com*, 2(6), pp. 87–91. Available at: [http://aijcnnet.com/journals/Vol\\_2\\_No\\_6\\_June\\_2012/11.pdf](http://aijcnnet.com/journals/Vol_2_No_6_June_2012/11.pdf).
- National Basic Mathematics Survey report, Maharagama: NIE. NBMS (2005)
- Savaş, E., Taş, S. and Duru, A., 2010. Factors affecting students' achievement in mathematics. *Mathematics learning*, 11(1).



# Factors Influencing the Classroom Climate on Academic Performance

Pragash Mithulaa\*, Padma Shanthi Y. Gamage

Department of Education and Training, University of Vocational Technology, Sri Lanka

## ABSTRACT

*The study conducted to find out the influence of the classroom climate on the academic performance of grade seven students in schools of Manmunai Pattu Division. Objective of the research are to review the existing factors of classroom climate in the grade seven and find out the influencing factors of classroom climate on those students' academic performance. Descriptive survey method was used in this study. The research hypothesized that the classroom climate factors affect the students' learning and their academic performance. Primary data was gathered by administering a questionnaire for students and focused group discussions for teachers. Secondary data was gathered by analysing students' second term marks and third term marks to check the students' academic performance. Data was analysed using MS Excel software, and frequency tables, bar graphs, and pie charts. It was found out that students' learning is affected by lack of student classroom participation and poor classroom management, with task orientation having the most negative effect. These factors have an effect on their academic performance related to English and science. Research recommends that resources should be made available to encourage good participation, assist students in improving their discipline abilities, and to assist students in improving their task orientation.*

**Keywords:** Academic Performance, Classroom Climate, Classroom Participation, Classroom Management, Task Orientation.

## 1. INTRODUCTION

### 1.1. Background of the Study

Classroom climate is dimension, specifically cohesiveness, material environment, formality and satisfaction and it has been identified these features to be good predictors of learning. Negative classroom climate is given to feel hostile, chaotic, and out of control, and a positive classroom climate feels safe, respectful, welcoming, and supportive of students learning. So the classroom climate is one of the most important factors affecting the students learning.

The ideal classroom is a positive place where a student can come to work toward specific goals set before them in the class objectives. (e.g., Hall,1982) state classroom climate is affected not only by blatant instances of inequality directed towards a persons or groups of people, but also by smaller, more subtle "micro-inequities" that can accumulate and has significant negative impacts on learning.

The classroom climate factors are lack of student participation, poor classroom management, influence of Instructional Material, teacher and student interaction, teaching methods and task orientation.

One of the factors that can influence students learning is the classroom climate. Classroom climate is a broad construct that is made up of student's feelings about their instructors and peers. It can make them feel safe, respectful, welcoming, and supportive of student learning. As a result, the classroom climate improves students' performance and aids teachers in conducting their lessons. (Chen and Weikart, 2008) State contrastingly, a negative school climate has been found to reduce student participation in school activities and student learning. This climate-achievement relationship appears to be robust for students across different grades, backgrounds, and cultures (Gregory 2007; Jia 2009). So the negative classroom climate is related to poor student outcomes.

---

\* Corresponding Author: E-mail - [mithulapragash@gmail.com](mailto:mithulapragash@gmail.com)

## 1.2. Justification of the Study

A set of educational, psychological, social, cognitive, organizational, and physical elements that can influence students' academic performance is referred to as classroom climate. The ideal classroom is a welcoming environment where students can work toward particular goals outlined in the class objectives. Climate could positively influence the health of the learning environment, or it could significantly impede learning. Thus, feedback about climate could play an important role in reform (Freiberg, 1998).

The classroom climate improves the learning environment for students. According to previous research findings Students feel comfortable in this climate, have good involvement, behave disciplinary, reach their goals, and explores and be true leaders of their own learning, and operate as a team. The study's purpose is to investigate the major difficulties at the Manmunai Pattu Division School, identify which factors have an effect on a student's studies and academics performance and assist in understanding the challenges that students face in the classroom and adapting to meet their needs.

## 1.3. Research Question and Objectives

### 1.3.1. Research Questions

1. What are the existing factors of classroom climate?
2. What are the influencing factors of classroom climate?

### 1.3.2. Research Objectives

1. To review the existing factors of classroom climate.
2. To find out the influencing factors of classroom climate.

## 2. LITERATURE REVIEW

### 2.1. Classroom Climate

Classroom climate is a board term intended to assess the perceptions that students have about different aspects of environment (Rowe, Kim, Baker, Kamphaus& Horne, 2010). Instructors to develop rapport and communicate interest and concern to student's is by talking openly about themselves in class, using appropriate self-disclosure (Hosek& Thompson, 2009), which increase students perception of comfortable classroom climate. Contrastingly a negative school climate has been found to reduce student participation in school activities and student learning (Chen &Weikart, 2008).

Theorists and researchers have underscored the importance for young adolescent's well-being of four aspects of school climate: the nature of relationship between teachers and students, autonomy is allowed in the decision-making process and the extent to which the school provides clear, consistent, and fair rules and regulations. These elements of the school climate are considered particularly important because they match with the developmental needs of early adolescents (Way, 2007).

### 2.2. Academic Performance

Classroom climate is a reflection of student's opinions of their academic experience (Reid &Radhakrishnan, 2003). Tschannen-Mora (2006) found that positive school climate was associated with students' academic achievement, after controlling for Many have relied on regional or state-wide tests and unstandardized measures (e.g., self-reported performance or grade point average, [GPA]). Although various studies have used standardized literacy and numeracy assessment data (e.g., Goddard, 2000; Sweetland& Hoy, 2000; Tschannen-Moran, 2006; Brand, 2008).

### 2.3. Influencing Factors in Classroom Climate

Lateness could result into poor academic achievement, disruption in class, difficulty in keeping accurate records, reduced ability to meet instructional target and damage of school reputation. (ETC, 2009).

Okwelle (2003) noted among other factors that, learner may develop negative attitude towards school resulting in late — coming or poor attendance because of non – employment of school leavers, repetition of class and insecurity. Social status and educational level of parent as factors that may influence school attendance and late coming. Alio (2003) Poor health is one disadvantage that is strongly linked to negative school outcomes (Champaloux & Young 2015).

#### 2.4. Influencing Factors of the Class Room Climate on Academic Performance

The quality of school life is defined as a synthesis of positive and negative experiences, and other feelings related to specific school life domains and outcomes (Leonard, 2002). While reflection does not need to take the place of a teacher’s assessment, it can be infused as part of an activity to enhance student performance because, if students are “makers of meaning,” their own thoughts and interpretation of their work and its overall impact “have to be part of the mix” (Yancey, 1998).

Lew and Schmidt (2011) concluded that student reflection through the use of journals resulted in students examining both the process and content of their learning and showed a weak to moderate correlation with improved academic performance. Their findings suggest that students’ ability to accurately reflect on their work improves over time, but does not significantly affect their overall performance on work in the classroom.

### 3. METHODOLOGY

The present study followed the descriptive research design. All the documents and, information are gathered by using qualitative and quantitative method. Data was gathered using both primary and secondary sources. Questionnaires and focus group discussions were administered to collect primary data, and student’s’ term test marks were used as the secondary data. The students participated in the questionnaire, and the teachers participated in the focus group discussion, while students' term test scores data was used to determine their academic success. Purposive sampling methods were used. 60 students and 20 teachers were selected. Students were chosen in a 1:5 ratio, teachers in a 1:12 ratio, and teachers were chosen purposely based on the subjects they teach. In this study, information was gathered from grade 7 students and their subject teachers at Manmunai Pattu Division 1AB, 1C, and Type II schools. All of the data was evaluated using MS Excel software, and the data was analyzed and the research study was completed.

Table 1- Sample Size

Name of the Schools in Manmunai Pattu Division	School Type	Sample size (Students)	Sample size (Teachers)
<b>Bt/ ArayampathyMaha.Vid</b>	1AB	Total Students – 45 1:5 = 9 Students	Total Teachers - 43 1:12 = 4 Teachers
<b>Bt/ Arayampathy R.K.M Maha Vid</b>	1C	Total Students -27 1:5 = 5 Students	Total Teachers – 41 1:12 = 3 Teachers
<b>Bt/ PuthukudiyerpuKannakiMaha Vid</b>	1C	Total Students - 77 1:5 = 15 Students	Total Teachers – 68 1:12 = 5 Teachers
<b>Bt/ KirankulamVinayagar Vid</b>	1C	Total Students – 86 1:5 = 17Students	Total Teachers – 39 1:12 = 3 Teachers
<b>Bt/ Notary Moothamby Vid</b>	Type II	Total Students - 8 1:5 = 2 Students	Total Teachers – 16 1:12 = 1 Teachers
<b>Bt/ Mavilangathurai V. Vid</b>	Type II	Total Students - 11 1:5 = 2 Students	Total Teachers – 21 1:12 = 2 Teachers
<b>Bt/ Thalankudah Sri V. Vid</b>	Type II	Total Students - 50 1:5 = 10 Students	Total Teachers – 30 1:12 = 2 Teachers
		Total - 60 Students	Total = 20 Teachers

## 4. FINDINGS

### 4.1. The Current State of Classroom Climate Factors for Grade 7 Students

The classroom climate factors in this research study are: lack of student classroom participation, poor classroom management, and task orientation.

#### 4.1.1. Lack of Student's Classroom Participation

19% of Students have difficulties continuing to participate on time because they lived far from the school and traveling is one of the primary issues for them to participate on time on some days. Students have transportation challenges, health issues, and others have family issues, resulting in low participation.

Focus group discussion: - 40 % of teachers agree the students had poor attendance, thus they were unaware of the previous class's topics, so they are unable to listen properly, and they did not participate fully. So, it is revealed that the lack of classroom participation influences the students' learning. Students are very slow to complete activities, whilst other students are quick to move on to the next subject, resulting in a lack of learning progress.

#### 4.1.2. Poor Classroom Management

Manmunai Pattu Division schools keep their classrooms clean and have strong discipline. 93% of students get permission to leave the classroom and stay quiet during the learning process. Others have that they have raised doubts and asked questions during the learning process. 34% of students converse with their peers when the subject is uninteresting and they are unable to focus. This is the most serious disciplinary issue in these areas. If any students misbehave during a classroom learning activity, they will be punished: the teacher will question them on current subjects, they will be sent outside for 10 minutes, beaten, and they will be advised. These are used to discipline students who misbehave in the classroom while a lesson is being presented. The majority of the students keep the classroom in good classroom management. However, poor classroom management has an influence on of students' learning activities.

Focus group discussion: - 20% of teachers agree some students do not follow the rules most of the time because they are aware of the outside environment, therefore they do not listen and attempt to go outside without permission. 20% of teachers agree several students purposefully spoke during class, failing to listen, and conversing with students from other classes because all the class are close without gaps. 65% of teachers agree that, if any student misbehave in the classroom, they use various methods to get their attention to the learning progress.

#### 4.1.3. Task Orientation

The majority 68% of students believe assignment will assist in determining their marks, it will support them in studying for the final exam, and they will say it is helpful to our own studies. Some students say it will assist in recognizing our grades. As a result, it is assisting us in improving our study group activities. Most students prefer group activities since working with peers allows them to gain more experience and knowledge. 63% of students perform quizzes throughout the learning activity to reduce students' laziness, but other 37% students are terrified of quizzes since they would feel terrible if they give incorrect answers. During the learning activity, the student using text books. It may be useful in guiding students' learning content. However some students do use textbooks during learning activities. 31% of students did not use, they listen to the teacher and only use textbooks for homework and assignments. Individual assignments assist students in their learning and provide them with confidence. Because the teacher instructs them to do individual work, they utilize a text book to complete individual assignments.

However, 48% of students are unaware of this and do not enjoy it; they claim they lack the confidence to complete individual assignments and prefer only group activities. Other one is Multimedia is an excellent teaching tool since it gives students real-world experience. The majority of 60% students like

to study, but they lack sufficient facilities. As a result, task orientation students have a significant impact on these areas.

Focus group Discussion: - Most of the students do not want to do assignments because they are unaware of the tasks and students talk with peers about other things and do not listen to the activity. Teachers engage students in group activities, discuss topic matters, provide subject-related activities, and ask questions during the teaching process some time they want a lot of time to finish their lesson that means they won't have time to do activities during the learning process. Some students don't know how to read; they don't know how to use books effectively. 80% of teachers agree that it provides them with valuable experience and allows them to participate fully and 20% of teachers said they don't know to handle the multimedia. 55% of teachers agree students do not like to do structure answer question types of assignments, preferring instead MCQ, handwork and activity assignments.

#### **4.1.4. Academic Performance of Grade 7 Students in Manmunai Pattu Division**

In this category, students' academic achievement is very poor. However, the majority of students struggle with task orientation, which is one of the reasons for their poor academic performance. The majority of students in the English subject marks range is 20-30, indicating poor English performance. In science, the majority of student's marks scored range is 40-50 which approximately a poor result is. As a result, the classroom climate has an influence on student's learning.

### **5. CONCLUSION AND RECOMMENDATIONS**

#### **5.1. Conclusion**

The classroom climate element has an influence on schools in the Manmunai Pattu division. Students are having difficulty participating in the learning activity. The majority of children have transportation challenges, which results in low attendance, failure to participate on time, and failure to arrive early to school, preventing full involvement in learning activities. Poor classroom management has a comparable effect on students, resulting in poor academic performance because students are aware of the outside environment, attempt to leave the classroom, disrupt rules and procedures, make noise, and converse with peers during the teaching process. They did not aware about their education. Some students were unaware of the assignment. They disliked doing SA-style assignments and preferred instead to complete handwork and activity assignments. Some students are unsure how to complete homework and require assistance.

The majority of students prefer to learn using multimedia in Manmunai Pattu Division. Some students did not know how to read and write properly, therefore they did not effectively use the school's text book. It has an effect on the learning and academic performance of students. Students benefit from group activities as they learn more about the subject and generate more thoughts about it. The group activities in this study were not well-organized, leading in students wasting time, and some students did not apply this form of group activities in their classroom. The majority of students prefer to study in groups, although schools do not implement this strategy efficiently. The majority of students receive poor grades in English and science. As a result, the elements have an impact on the students' learning. In this study, task orientation has a significant influence on students learning, as well as their academic performance.

#### **5.2. Recommendations**

The technological basis of schools should be improved, and schools should be designed in such a way that multimedia use is encouraged. As a result, the students learn through the use of videos, slides, animations, photos, and voice recordings to achieve the objectives of the classes. Conduct more group activity work relating to the topic matter, guiding the students step by step so that everyone pays attention. Students should be educated and trained using strategies that increase self-motivation so that they are self-driven to attain academic success and lifelong learning. Teacher should guide the students to perform well in structure answer questions in their English and science subjects. It is help for there are end test examination. Establish a special class for students who have difficulty reading and writing the subjects. It has the potential to reduce their problem. Arrange a meeting with parents to explain the

student's academic status. So that the parent becomes aware of the student's current situation as a result, parents provide an environment in which students can learn on their own. The research recommends most of the students like to undertake hand-over assignments, therefore increase the number of hand-over assignments so that students can obtain knowledge on their own. This will help students learn more independently.

## REFERENCES

- Cheiah Arulmol 2013, *Family background and classroom climate correlates of students achievement in science in kalkudah educational zone , batticaloa district, srianka, intenational research conference*, Eastern University, Sri Lanka, <https://www.researchgate.net/publication/32083763>
- Dr.Chuanth Kulasekara (Team Leader) Prof.DayalathLekamge Dr.(Mrs) IndraniTalagala Mr.ShanthaR.Yapa, 2016, *Study on development of learning environment in general education in Sri Lanka*, National Education Commission. [www.nec.gov.lk](http://www.nec.gov.lk)
- Ellis, K. 2000, *Perceived teacher confirmation: The development and validation of an instrument and two studies of the relationship to cognitive and affective learning*, Human Communication Research, <https://www.onlinelibrary.wiley.com>
- Freeman,T.M ,Anderman,L.H.,&Jensen,J.J. 2007, *Sense of belonging in college freshman at the classroom and campus level*. Journal of Experimental Education. <https://www.jstor.org>
- Freiberg, H.J. 1999, *School climate: measuring, improving and sustaining healthy learning environments*, London: Falmer Press, <https://www.isbe.net>
- Hosek, A.M., & Thompson,J.2009, *Communication privacy management and college instruction: Exploring the rules and boundaries that frame instruction private disclosures, communication education*,<https://www.researchgate.net/public>
- Ian M.Evans, Shane Y.Harvey, Laura Buckley & Elizabeth Yan 2009, *Differentiating classroom climate concepts: academic, management, and emotional environments*, New Zealand Journal of Social Science Online. <https://www.tandtonline.com/doi/pdf>
- Jason J.Barr , 2016, *Developing a positive classroom climate*, The IDEA Center, <https://files.eric.ed.gov/fulltext/ED57>
- Katharina Rathmann, Max G. Herke, Klaus Hurrelmann, Matthias Richter 2018, *Perceived class climate and school-aged children's life satisfaction: The role of the learning environment in classrooms*, PLOS ONE, <https://www.journals.pos.org>
- Melissa Mariani, Christopher A.Sink, Elizabeth Villares, Caronlyn Berger July 5, 2019, *Measuring classroom climate: A validation study of the my child's classroom inventory-short form for parents*, Professional school counseling, <https://www.journals.sagepub.com>
- MarijaAakic, Zora Raboteg-Saric 2011, *School and classroom climate and student (dis)satisfaction with school*, Institute of Social Science Ivo Pilar, Zagreb, Croatia, <https://www.researchgate.net/publication/257067234>
- Rosenthal R 1991, *Teacher expectancy effects: a brief update 25 years after the Pygmalion experiment*, Journal of Research Education. <https://www.lscp.net>
- School Census- Department of Census and Statistics 2012, *Preliminary report of school census, statistical website of Sri Lanka*, <https://www.statistics.gov.lk>
- Shawn Guffey, Ann Higgins-D' Alessandro.2013, *A review of school climate sesearch*, American Educational Research Association. <http://rer.aera.net>
- Sidelinger, R. J.,& Booth-Butterfield, M, 2010, *Co-constructing student involvement: An examination of teacher confirmation and student-to-student connectedness in the college classroom*, Communication Education, <https://www.researchgate.net>
- Wade,R, 1994, *Teacher education students views on class discussion: Implications for fostering critical reflection*, Teaching and Teacher Education. <https://www.sciencedirect.com>

# Factors Influencing the Usage of Physical Resources on Academic Performance

G.G.W.E. Kumaradasa\*, Padma Shanthi Y. Gamage

Department of Education and Training, University of Vocational Technology, Sri Lanka

## ABSTRACT

*This study was conducted to find out the factors influencing the usage of physical resources on academic performance of grade 10 students in rural schools. This study was based on schools in division II, Ratnapura. The objectives of the study were to review the current situation of usage of physical resources and find out the factors influencing the usage of physical resources on students' academic performance. The researcher used the descriptive survey design and mixed approach. 40 students and 14 teachers from five schools were the sample of this study. Purposive sampling was used to select the respondents. The researcher used a questionnaire for students and focused group discussions for teachers. Further students' term test marks were used as secondary data. Descriptive statistical techniques were used in this study. Data was analyzed using Microsoft Excel software. The study findings highlighted that the students doing their academic work with limited physical resources. Insufficient physical resources and lack of trained staff were the main factors for not having sufficient physical resources. The academic performance of students in science and mathematics is very poor with low marks. The research recommends allocation of laboratories with sufficient laboratory resources and instructional materials with resource persons to rural schools.*

**Keywords:** Academic Performance, Physical Resources, Rural Schools, Usage of Resources

## 1. INTRODUCTION

### 1.1. Background of the Study

Education promotes human capital as an asset with a higher or lower rate of return, depending on the quality of the education provided. Physical resources include any physical items the school currently owns. These include school furniture, laboratory, equipment, technology, instructional materials, manipulatives, and any other materials within the school. Physical resources in a school have a direct impact on the learning environment and a key determinant of academic performance (Amadi, 2019).

Laboratory equipment and instructional materials are two type of physical resources in the schools. Laboratory tools/equipment and materials are very important to conduct for the practical tests. Proper usage of this lab resources helps to students understand to the scientific concepts. Instructional materials play a very important role in the teaching learning process. Instructional materials are printed and electronic instructional materials. Effective usage of these resources help the students achieve their educational goals.

The usage of physical resources is very important because of its role in the attainment of educational objectives and goals. The extent to which an educational institution attains her objectives is directly proportional to the educational resources usage (Olelewe, 2014). Some of the factors that lead to poor performance are lack of resources or opportunities in most schools, especially schools in rural areas (Thilkarathna, 2008). There are many problems in public rural schools due to the impact of physical resources. Students living in rural areas will be little exposed to the use of technology because the facilities provided for them are insufficient and lack of resource persons (Motala, 2015). This will make their learning process less efficient, and they will have less knowledge about current issues and how to use technology. Proper usage of physical resources is very important to increase to students' performance.

---

\* Corresponding Author: E-mail - [wathsala.e.kumaradasa1996@gmail.com](mailto:wathsala.e.kumaradasa1996@gmail.com)

## 1.2. Justification of the Study

In Sri Lanka, there is a disparity in the distribution of physical resources among government schools. The physical resources available to urban national schools are similarly not available to rural schools. The number of students in rural schools is also declining. Physical resources are very helpful in enhancing the academic performance of students in schools. Dhakal K. (2020) examined that lack or inadequacy of physical resources, lack of resource persons, time constraints and issues of management leads to a decline in the academic performance of students. It is a big issue regarding the school education of students. School physical resources play an important role in reducing the effect of socioeconomic features on academic performance and creating equal opportunities for students (Savasci, 2013).

Many rural schools of the Sri Lanka do not have adequate physical resources for students in Sri Lanka (Thilkarathna, 2008). Schools have adequate resources but do not use them for other reasons as lack of trained staff. Time allocation, issues of management, maintenance of the resources (Kapur, 2019). That is negatively affect students' academic performance. Physical resource such as laboratory tools, equipment and materials and instructional materials are considered for this study. Accordingly, this study observes how the usage of physical resources affects the academic performance of the students of the 1AB, 1C and type 2 schools in the division II, Ratnapura.

## 1.3 Research Questions and Objectives

### 1.3.1 Research Questions

This study was guided by the following research questions:

1. What is the current situation of usage of physical resources?
2. What are factors influencing usage of physical resources on students' academic performance?

### 1.3.2 Research Objectives

This study was guided by the following research objectives:

1. To review the current situation of usage of physical resources.
2. To find out the factors influencing usage of physical resources on students' academic performance.

## 2. LITERATURE REVIEW

### 2.1. Educational Physical Resources

Physical resources are the raw materials which are used to achieve an objective or goal in an organization (Amadi, 2019). Physical resources are real assets that can be easily seen and displayed in any institution and made by man through his abilities and skill (Dangara, 2016). Physical resources in the education system include classrooms / lecture rooms, staff offices, vehicles, health centers, libraries, instructional materials, laboratories and so on, which contribute directly or indirectly to the achievement of goals (Dangara, 2016). Classrooms, laboratories, library, health facilities, recreational facilities, toilet facilities, instructional materials and landscape are eight important physical resources to improve student academic performance (Zainuddin, 2017).

### 2.2 Usage of Physical Resources in Schools

Usage is the action of using something in an effective way (Leviton, 1981). Proper usage of physical resources is important for maintaining productivity (Anon., 2018). The effective usage of physical resources most important component in the schools. Without them, it influences the quality of education and the efficiency of students and teachers (Anon., 2018). The impact of the usage of physical resources should also be taken into account in promoting good performance in schools (Grace, 2008). The proper use of school facilities affects a teacher's desire to teach and in turn, this positively affects student's



academic performance (Ilomo, 2016). The proper usage of physical resources such as laboratories and text books play an important role in achieving educational goals and academic performance of the students (Wanjiku, 2013). Usage of physical resources is the process of teaching brings about generative learning since it refreshing student's sense as well as motivates them (Olagunju, 2009).

### **2.3 Factors Influencing Usage of Physical Resources**

Lack of laboratory equipment hinders the effective use of laboratories which may contribute to the functioning of the science subject (Wanjiku, 2013). Olaedo (2018) observed that the insufficient in the quantity of resources provided invariably effected its usage. Inadequate learning materials and equipment leads to poor performance in mathematics (Mbugua, 2012).

Lack of appropriate materials like text books are some challenges about instructional materials in schools (Dhakal, 2020). Problems with the use of instructional materials are lack of materials, lack of funding for instructional materials and time (Terty, 2016). Dhakal K. (2020) examined that insufficient materials, lack of appropriate materials, time constraint, and lack of support from authority are influencing factors of the proper usage of instructional materials.

One of the factors contributing to none proper usage of physical facilities, equipment and supplies in secondary schools are lack of maintenance of equipment, materials and supplies (Ugwuanyi, 2013). Lack of trained staff to handle physical resource is one of influencing factor of the resource usage (Ugwuanyi, 2013). Inappropriate teaching and learning materials, lack of knowledge, lack of financial resources, lack of preparedness teachers, lack of equal rights and opportunities, problems introducing modern and innovative methods, problems organizing workshops and training programs, problems in providing machinery and equipment, occurrence of conflicts and disagreements were some limitations of the resource usage in schools (Kapur, 2019).

### **2.4. Influence of the Usage of Physical Resources on Academic Performance**

Academic performance is the educational goal that a student, teacher or institution must achieve within a specific period of time and the success and failure of any educational institution is measured in terms of academic performance (Narad, 2016). A positive relationship between the efficient usage of physical resources and student academic performance (Grace, 2008). Success in the academic performance depends on the suitability of materials, availability of materials, and the proper use of the materials (Delacruz, 2012). Stated on research which the higher score on test or examination were comes from better science laboratories (Young, 2003). Inadequate learning materials and equipment leads to poor performance in mathematics (Mbugua, 2012).

### **2.5 Influence of the Usage of Physical Resources on Academic Performance of Students in Rural Schools**

Rural areas such as public water supply, electricity, good roads and school infrastructure are lacking to improve the living conditions of the community (Asare, 2015). Problem regarding unequal distribution of physical resources between province, rural and urban areas are still intact (Motala, 2015). Many rural schools do not have the physical resources library and laboratory facilities are limited, especially for subjects such as English, mathematics and science (Thilkarathna, 2008).

## **3. METHODOLOGY**

This study adopted a descriptive survey design. The sample consisted 40 students and 14 teachers of public schools in in division II, Ratnapura. Students were selected using 1:5 ratios. Teachers were selected purposively according to the subjects they teach with using 1:1 ratio. The population and the sample of the study are given in Table 1.

Table 1: Population and Sample

<b>Total population</b>	<b>Grade 10 students and teachers of public schools in Ratnapura district</b>
<b>Target Population</b>	Grade 10 students and teachers of public schools in division II, Ratnapura
<b>Sample</b>	Sample 1 - 40 students of grade 10 Sample 2 - 14 teachers
<b>Sampling Technique</b>	Purposive Sampling Method

Primary data was collected from two main instruments namely; Questionnaire and Focus group discussion. The study used mid and end term test marks of science and mathematics to measure the academic performance of students in grade 10 as secondary data. Descriptive statistical techniques used for data analysis. Data collected were edited, coded, summarized and analyzed using Microsoft Excel software in conformity with objectives of the study. Descriptive statics such as frequencies and percentage were used in the analysis of the demographic and characteristics of respondents.

## 4. FINDINGS

### 4.1 Current Situation of Usage of Physical Resources

Table 2: Usage of Physical Resources

<b>Physical resources</b>	<b>percentage of usage</b>	<b>percentage of not usage</b>
1. Science laboratory	92.50 %	7.50%
2. Science lab	88.50%	11.50%
• Tools	87.50%	12.50%
• Equipment	58.50%	42.50%
• Materials		
3. Math laboratory	17.50%	82.50%
4. Math lab	16.66%	83.33%
• Equipment	15.50%	84.50%
• Materials		
5. Printed Instructional Materials	54.50%	45.50%
6. Electronic Instructional Materials	25%	75%

The use of science laboratory and science laboratory materials in the schools in division II, Ratnapura was also in fairly condition but some schools in this division do not use these resources.82.50% of students do not use math lab and math lab equipment with materials for practical tests.45.50 % of students do not use printed instructional materials. 75% of the students do not use electronic instructional materials.

### 4.2. Factors Influencing Usage of Physical Resources on Students' Academic Performance

#### 4.2.1 Laboratory Tools / Equipment and Materials

According to the findings of the study, students do not use science laboratory maximum for their practical test in schools of division II, Ratnapura. 32 % of students stated that insufficient tools/equipment or materials for practical tests was a major factor of the usage of science laboratory resources. 25% of students stated that insufficient time allocation was a second major factor. 21% of students stated that lack of trained staff was a least influencing factor for the usage of science laboratory resources for practical tests. Most of the students do not use math lab materials for practical test in their schools. 39% of students stated that insufficient tools/equipment and materials was a major factor of the usage of math lab resources. 22% of students stated that second major factor was a lack of trained

staff for their usage of math lab resources. 19% of students stated that poor commitment of the management was a least influencing factor for the usage of math laboratory resources for practical tests in schools of division II, Ratnapura.

#### **4.2.2. Instructional Materials**

According to the findings of the study, 60% of the students in sample do not use printed instructional materials maximum level in schools of division II, Ratnapura. 39% of students stated that insufficient printed instructional materials were a major factor for not usage it. 23% of students stated that poor commitment of the management was a second major factor. 17% of students stated that lack of trained staff was a least influencing factor for the usage of printed instructional materials. 80% of the students in sample do not use electronic instructional materials maximum level. 33% of students stated that lack of trained staff was a major factor for not usage it. 28% of students stated that insufficient electronic instructional materials were a second major factor. 19% of students stated that insufficient time allocation for the use of materials was a least influencing factor for the usage of electronic instructional materials in schools of division II, Ratnapura.

#### **4.2.3 Academic Performance of Grade 10 Students in Division II, Ratnapura**

According to the findings of the study, students' academic performance was very poor. 70 % of students have science marks under the 40. The average mark in both terms is calculated, the average for science is 34.2. And 70 % of students have mathematics marks under the 30. The average mark in both terms is calculated, the average for mathematics is 22.38. However, students learn under the low physical resources.

### **5. CONCLUSIONS AND RECOMMENDATIONS**

#### **5.1. Conclusions**

From the study findings, some schools did not use science laboratory in division II, Ratnapura. Science laboratory tools equipment and materials were insufficient for effective usage in these schools. These students studied under the limited science laboratory resources. The findings highlighted that the most of the students did not use math laboratory. Math laboratory equipment and materials were insufficient or lack for effective usage in these schools. These students studied under the limited math laboratory resources or without using any of these resources. The findings in this study shows the printed and electronic instructional materials were insufficient for effective usage. Lack of trained staff to handle the laboratory equipment/materials and electronic instructional materials in schools. The findings highlighted that academic performance of the students was very poor. Student's science and mathematics marks were under the lower range.

#### **5.1. Recommendations**

According to the findings, researcher gives some recommendations. Those are establish the well-equipped science and math laboratories with provide the required amount of laboratory tools/equipment and materials to the schools in division II, Ratnapura, provide to the required amount of printed instructional materials and electronic instructional materials in schools which are either inadequate or completely lacking, allocate the resource persons to handle laboratory equipment/materials and electronic instructional materials, regular training and retraining of teachers on usage of laboratory resources and instructional materials. As well as teachers should encourage and improve students' science and mathematics performance using relevant physical resources.

## REFERENCES

- Adeogun, G. I. O., 2008. Relationship between educational resources and students academic performance in Lagos State nIgeria. *International Journal of Education Management*, pp. 144-153.
- Ajoke, A. R., 2017. The Importance of Instructional Materials in Teaching English as a Second Language. *International Journal of Humanities and Social Science Invention*, pp. 36-44.
- Amadi, E. C., 2019. Physical Resources Availability and the Academic Performance of Students in the Universal Basic Education Scheme, River State. *International Journal of Innovative Development and Policy Studies*, pp. 13-23.
- Tempus Resource, 2018 *Tempusources* [Online] Available at:<https://www.tempusresource.com> [Accessed 30 November 2018].
- Asare, A. O. S., 2015. Rural–Urban Disparity in Students’ Academic Performance in Visual Arts Education: Evidence From Six Senior High Schools in Kumasi, Ghana. *SAGE journals*, pp. 1-14.
- Baiju K., B. M., 2018. Significance Of Mathematics Laboratory In Schools. pp. 1-9.
- Bucher, A. a. K. L., 2002. *Management of Physical Education and Sports. (12th Ed). New York: McGraw Hill*, s.l.: s.n.
- Dangara, U. Y., 2016. Educational Resources: An Integral Component for Effective School Administration in Nigeria. *Research on Humanisties and Social Sciences*, pp. 27-37.
- Dhakar, K. R., 2020. Challenges of the Use of Instructional Materials in Geography Class-room in Secondary School: Nepal. *Journal of Geographical Research*, pp. 36-39.
- Grace, A., 2008. Effective usage of physical resources in relation to academic performance . a case study on Kimathi primery school, 2008). pp. 1-61.
- Aturupane, V. D. R. J. M. S. U. S., 2011. *Strengthening Science Education in Sri Lanka*, s.l.: South Asia: Human Development Sector .
- Ilomo, B. M., 2016. The Availability of Teaching Facilities and Their Effects on Academic Performance in Ward Secondary Schools in Muheza. *International Journal of Education and Research*, pp. 571-582.
- Jain, P., 2017. Impact of Mathematics Lab on Schools Students. *International Journal of Engineering Science and Computing*, pp. 1-2.
- Kapur, R., 2019. Impact of Resource Utilization in Education. pp. 1-17.
- Laura C. Leviton, E. F. H., 1981. Research On the Utilization of Evaluations: A Review and Synthesis. *SAGE Journals*.
- Matthew C Nwike, O. C., 2013. Effects of use of instructional materials on students achievement in agricultural science. *Journal of Educational and social Research* , p. 103.
- Mbugua, K., 2012. Factors contributing to students’ poor performance in mathematics at Kenya: a case study of Baringo county. *American International Journal of Contemporary Research*.
- Motala, S., 2015. Equity, access and quality in basic education. *Journal of Education*, pp. 160-174.
- Mudulia, A. M., 2012. The relationship between availability of teaching/learning resources and performance in secondary schools science subjects in Eldoret Municipalty, Kenya. *Journal of Emerging trends in educational research and policy studies*, pp. 530-536.
- Narad, B. A., 2016. Academic Performance of Senior Secondary School Students: Influence of Parenta Encouragement and School Enviornment. *Rupkatha Journal of Interdisiplinary Studies in Humanities*, pp. 12-19.
- Ndihokubwayo, K., 2017. Investigating the status and barriers of science laboratory activities in Rwandan teacher training colleges towards improvisation practice. *Rwandan Journal of Education*, pp. 47-54.
- Offorma, G., 1990. *Offorma, G Impact of teachers; use of resources on secondary school students’ learning outcome in French*, s.l.: s.n.
- Olagunju, O. A., 2009. Production and utilization of resources in biology education. A case study of South West Nigeria secondary schools. *International Journal of African & African American studies.*, pp. 49-56.
- Olelewe, C. J. N. C. A. C. T., 2014. Availability and Utilization of Educational Resources in Selected Rural Communities of Enugu State: Implications for Achieving Universal Primary Education of Millennium Development Goals (MDGs) in Nigeria. *Educational Research International*, pp. 15-24.
- Savasci, E. T., 2013. The relationship between Educational Resources of School Academic Achievement. *International Education Studies*, pp. 114-123.

- Terty, J. L., 2016. *Role Of Instructional Materials In Academic Performance In Community Secondary Schools In Rombo District*, s.l.: s.n.
- Thilkarathna, A. G. R. J. R. P., 2008. *Educational Oppertunities for the poor in Sri Lanka*, Colombo: Institute of Policy Studies of Sri Lanka.
- Ugwuanyi, J. I., 2013. *Availability, Adequacy and Utilization of Physical Educational Teaching Resources in Secondary Schools in Enagu State*, s.l.: s.n.
- Wanjiku, M., 2013. Availability And Utilization Of Educational Resources In Influence Students Performance In Secondary Schools In Mbeere South, Embu County , Kenya. pp. 1-108.
- Young, E., 2003. *Do K-12 School Facilities Affect Education Outcomes?*, s.l.: TACIR publication .
- Zainuddin, F. S., 2017. The School Facilities towards the Improvement of students' Academic Achievement: Case Stude- Secondary Schools in Klang. *Journal of Modern Education Review*, pp. 647-653.

# Ground Reality of Emergency Remote Teaching during Covid 19 Pandemic: Experiences of Teachers of English in Uva Province, Sri Lanka

M.P.S.P Dias<sup>1</sup>, S.B.C. Rangana<sup>2</sup>, J. A. M. Buddhima Karunarathna<sup>3</sup>, A. A. Gunawardana<sup>\*3</sup>

<sup>1</sup>D.S Senananayake National School, Beruwala, Sri Lanka

<sup>2</sup>Siyane National School, Dompe, Sri Lanka

<sup>3</sup>Department of Language Studies, University of Vocational Technology, Sri Lanka

## ABSTRACT

*Outbreak of COVID19 pandemic has triggered a swift shift from traditional face to face teaching learning patterns to online teaching learning patterns. This unanticipated paradigm shift in education methods has raised a number of new challenges to teachers teaching especially in rural schools. Teachers of English are equally constrained to accept these challenges and facilitate students' education by adapting to deliver through new technology. This research focuses on investigating ground realities of emergency remote teaching (ERT) with special focus on the availability of infrastructure facilities and means of receiving formal training to support online teaching for teachers of English. As a survey study, a questionnaire was distributed among 31 teachers of English in the Uva Province of Sri Lanka. Findings suggest that both teachers of English and students in the Uva Province still undergo difficulties in finding devices, proper network coverage, efficient teaching material, etc. Poverty of students and lack of experience in teaching English via online are two other major obstacles in successful implementation of ERT. Therefore, it is recommended that the authorities find solutions for this dire need of infrastructure for both teachers and students while providing appropriate formal training opportunities for teachers specifically to teach English via online modes.*

**Keywords:** Emergency Remote Teaching; English Language Teaching; Infrastructure Facilities; Training; Uva Province

## 1. INTRODUCTION

As a lower middle income country, Sri Lanka as a policy provides free education from primary level to tertiary level through which the majority of students ultimately succeed in their lives. However, the outbreak of COVID 19 pandemic has severely impacted the education system in Sri Lanka since the year 2020. Irrespective of technological advancements in modern education in the world, the education system in Sri Lanka was accustomed only to follow traditional face to face teaching learning pattern which was swiftly replaced by the online method with the introduction of quarantine measures. As a result, the system now experiences massive transformations from the traditional teacher student encounters to virtual encounters. Each level of the system ranging from preschools to universities is compelled for this transition from classroom learning to online learning. Based on the findings of Garcia M., Hayashi R., Hewagamage K. P. and Maddawin A. (2020) on the responses towards education under new normalcy in Sri Lanka, tertiary level education has made positive moves towards online learning. "According to the universities surveyed, nearly 90% of student respondents have been able to access online education. This rate is comparable to developed countries like Japan" (p. 1).

However, having been tremendously impacted by the pandemic, school level education in the country still struggles to rebuild the structured flow of learning, causing psychological issues for students, teachers as well as parents alike.

This unanticipated paradigm shift in learning teaching methodology has raised a number of new challenges to teachers teaching especially in rural schools. Teachers of English are equally constrained

---

\* Corresponding Author: E-mail - [anoma@uovt.ac.lk](mailto:anoma@uovt.ac.lk)

to accept these challenges and go an extra mile as facilitators by learning and adapting to deliver through new technology while engaging their students more effectively.

To make language learning more effective, it requires more interaction from the learner. Hence, teaching English language through online mode is undeniably a challenging task for teachers of English. Since the outbreak of the pandemic, several research studies on different aspects of online learning and teaching in both schools and higher education institutions have been carried out. However, research investigating experiences of teachers of English towards the use of new technology as a solution for disrupted traditional education is still needed. Further, it is essential to distinguish between online teaching and emergency remote teaching (ERT) because the transition the Sri Lankans experience at present is ERT which differs in many aspects to online teaching. For instance, unlike ERT, online learning ensures higher standards in teacher student interaction, learner engagement, providing feedback, user-friendly technology for all teachers and students. More importantly online learning focuses on achieving learning objectives rather than simply covering content. Therefore, this research study is an attempt to investigate the availability of infrastructure facilities for teachers of English to support ERT and to find out the means of receiving training for them to accept this challenge positively.

Considering the setting of the research study, Kalugalagedera T., Licht S. and Sarma V. (2018) introduce Uva Province in Sri Lanka as one of the three provinces where the majority of population lives in rural sector and claims to be the most educationally backward considering possibilities to have access to education, its quality and learning outcomes. Further, when considering the performance of students on the three main subjects English, Mathematics and Science, Uva Province is once again one of the three provinces obtaining the lowest scores in the country for these subjects. Hence, the main focus of this study is on the teachers of English from the Uva Province of Sri Lanka and the researchers intend to focus on achieving the following objectives.

1. To investigate the availability of infrastructure facilities to support online teaching for teachers of English.
2. To find out the means of receiving training for the teachers of English to teach online

## 2. REVIEW OF LITERATURE

The global virus outbreak necessitated a complete, rapid overhaul of our traditional teaching and learning processes in local government schools. Due to the school closures, courses or modules at all levels were delivered in fully remote online formats (Bond, 2021). In general, online education provides the flexibility of learning and teaching anywhere at any time. However, the COVID-19 pandemic prompted a transition from traditional to remote learning at all levels of education termed Emergency Remote Teaching (ERT) (Hodges, 2020). “The primary objective in these circumstances is not to recreate a robust educational ecosystem but rather to provide temporary access to instruction and instructional supports in a manner that is quick to set up and is reliably available during an emergency or crisis” (Hodges, 2020).

In contrast to the virtual courses initially designed and planned to be delivered electronically, ERT refers to a sudden and interim change in instruction delivery to an online delivery mode due to a severe disaster. Furthermore, ERT in this specific situation created an obligation for students, while well-planned distance learning provides an alternative, flexible learning environment (Bozkurt & Sharma, 2020).

On the other hand there are several examples of other nations reacting to school and university closures during a crisis by implementing models such as mobile learning, radio, blended learning, or other contextually more practical alternatives (O’Keefe, 2020). When discussing the drawbacks of ERT, it has been associated with a number of problems, including those at the technological, educational, and social levels. The quality and availability of internet connections, as well as students' access to the requisite gear are technological obstacles. Instructors' and students' low digital competencies, teachers' incapacity to handle online resources and build digital learning environments, a lack of engagement and

motivation, and teachers' trouble assuring social and cognitive presence are all pedagogical problems (Seabra, 2020). The absence of contact among students or between students and instructors, the physical circumstances for learning at home, and the availability and support of parents are all examples of social difficulties (Bozkurt & Sharma, 2020). Changes in work rhythms and workload were seen, although not necessarily in a negative aspect, as some instructors saw this as an opportunity for progress. Parents who are also working as teachers who have supervisory responsibilities report that working is "nonstop". Teachers reported putting in a lot of effort to provide interesting activities for their kids, which occasionally generated conflict with families and their expectations (O'Keefe, 2020). Teachers were concerned about their students' vulnerability, particularly those with learning difficulties and those who were isolated. A Portuguese research emphasized the need of teachers' digital capabilities, which were identified as one of the key barriers to ERT. The study discovered a gender and age gap in teachers' levels of proficiency, as well as lower levels of digital competence among younger children's instructors. Teachers with less digital proficiency reported a greater burden and more unfavorable feelings about ERT (O'Keefe, 2020).

### **3. METHODOLOGY**

As a survey study, firstly, a questionnaire was devised to align with the set objectives of the research to collect data. Secondly, the questionnaire was piloted and edited accordingly. Thirdly, the questionnaire was prepared in the form of a Google Form and finally, distributed for collection of primary data.

As the sampling technique snow bowling sampling technique was utilized in collecting data from the participants. As the potential participants from the population, 05 in-service teachers of English from the Uva Province were forwarded the questionnaire and they were requested to forward the questionnaire to other in-service teachers of English teaching in the same Province. After one month, the end of the data collection period, the researchers received 31 responses; hence, the sample size of the study is 31. From the sample, 83.9% of the participants were teachers of English from schools administrated by the Provincial Councils. When 9.7% of the participants were from National Schools, 6.4% of the participants were from Plantation Estate Schools. Considering the type of school the participants serve as teachers of English, 16.1% of them belonged to 1 AB type school category comprising grades up to the Advanced Level including science stream classes. 38.7% of them were teaching in 1C type school category comprising grades up to Advanced Level but only Arts and/or Commerce streams. 29% of the participants belonged to Type 2 school category comprising classes only up to Grade 11. 12.9% of the participants belonged to Type 3 schools comprising classes only up to Grade 8. Some of these stratifications were considered in the in-depth analysis of the collected data. The data was analyzed both quantitatively and qualitatively.

The study comprised a few limitations. Firstly, the researchers had to limit the number of participants of the study to 31. Although the anticipation was to involve 50 participants, only 31 teachers of English from the Uva Province responded by the end of the data collection period. The major reason for this limitation was the trade union action of the Government school teachers by refraining from ERT and most of the teachers were not willing to participate the survey. Secondly, the study was limited to the Uva Province of Sri Lanka. As a result, the findings and recommendations drawn from the analysis of data can be generalized only to similar provinces in Sri Lanka such as Northern and North Central Provinces. Thirdly, the main focus of this study was only on the teachers of English because language learning is more practice, therefore teaching English as a Second Language remotely needs more requirements such as more student interaction.

### **4. ANALYSIS AND DISCUSSION**

#### **4.1. General Experiences in Remote Teaching**

Figure 1 illustrates how often the teachers of English in the Uva Province conducted ERT in 2020 and 2021.



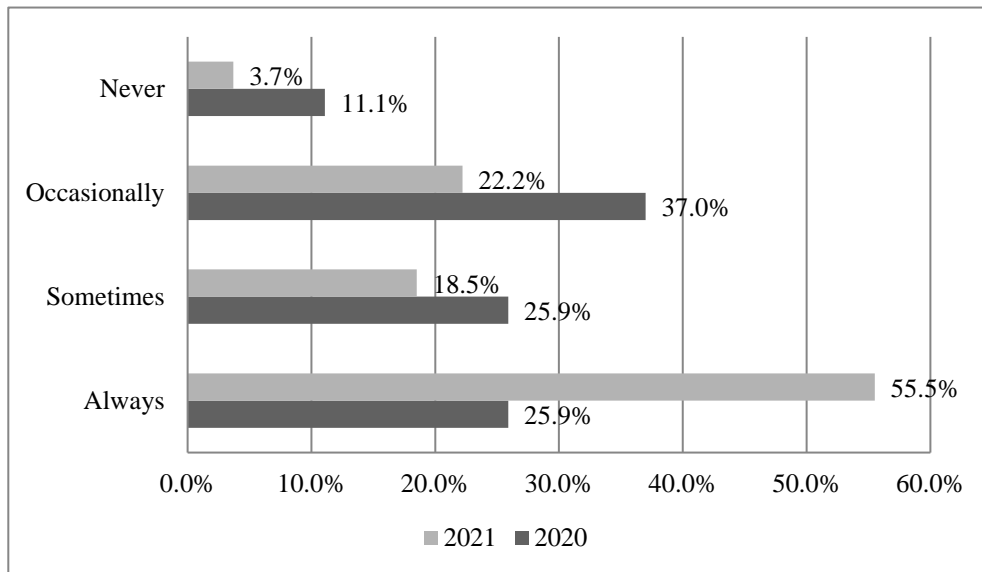

Figure 1: Frequency of Conducting ERT in 2020 and 2021

According to Figure 1, when the frequency of teaching English remotely in the year 2020 and 2021 was compared, it was observed that the teachers of English teach more often at present than previously when teaching remotely was a new concept for them. The percentage of the teachers who have selected the options 'never' and 'occasionally' has reduced remarkably in the year 2021 when compared to the year 2020, and the percentage of teachers who have selected the options 'sometimes' and 'always' has increased in the year 2021 when compared to the year 2020.

However, when the collected data was analyzed in depth, it was observed that the participants who teach English in the Plantation Estate Schools have selected the option 'never' for both years 2020 and 2021. Giving reasons for selecting the option 'never', they have mentioned that students from such schools mainly lack facilities to join classes via online platforms. In addition, poor network connections, poor learning capacity of the students, lack of parental attention on students' education, and students' lack of awareness in technology related to remote teaching are other barriers for them in ERT.

#### 4.2. Availability of Infrastructure Facilities

From the analysis of the responses received on the availability of infrastructure facilities for teachers of English to teach English remotely via online, it was revealed that 48% of the participants use only smart phones and another 48% use only laptops for online teaching. Only a 4% of them use both laptops and smart phones. Among the participants, 29% claimed that they had to purchase new devices such as smart phones, laptops, web cameras, routers, headphones, etc. to teach via online while others use devices which are already available with them.

Further, it was revealed that 80.7% of the participants use both Whatsup and Zoom as online teaching platforms. When 3.2% of the participants use only Zoom, 9.7% use only WhatsApp. 3.2% of the participants use the online platform named Telegram. 3.2% have mentioned that they use both WhatsApp and Google Classroom to teach remotely.

When the participants were enquired whether they received assistance of any nature to be equipped with such infrastructure for remote teaching, 93% of the participants responded saying that they were not assisted by any organization to purchase the devices to support ERT, whereas 7% of the participants were assisted. The respondents who have mentioned that they were assisted to purchase devices are the teachers who are teaching in National schools. When considering the assistance received to purchase data package, when 90% of the participants revealed that they were not assisted, 10% of the participants teaching in schools governed by Provincial councils and National schools. Analyzing responses to access online teaching platforms free of charge, 77% of the teachers have not been provided with

opportunities to access online teaching platforms freely, but 23% of the teachers teaching in schools governed by Provincial councils and National schools have been supported. Teachers who have been supported with the above discussed infrastructure facilities needed for ERT have been provided by either school administration or Past Pupils' Associations of schools or non-profit organizations or sponsors.

Analysis of responses on the satisfaction of the teachers with the support they receive from administrative bodies to teach English remotely through online modes, it was noted that only a 24% of the participants are satisfied with the facilities available for remote teaching. Majority of the participants, 76% are not satisfied with the support they receive from their administrative bodies because they still find issues with devices, poor network coverage, lack of efficient teaching material such as smart boards and white boards, poverty of students and inability to conduct useful lessons using only a smartphone. In addition, they have mentioned that they did not receive any proper training for remote teaching and financial support for data charges. The participants had been supervised when practicing ERT but had not been provided any guidance or advice on how to engage in ERT successfully.

#### 4.3. Formal and Informal Training Received For ERT

As shown in Figure 2, analysis of responses on formal training provided to teach English remotely via online revealed that 82.6% of the participants had not received any kind of training to help them teach English remotely. However, 17.4% of the participants have undergone some training facilitated at divisional level and mostly at school level. Out of that 10.5% had received training but not specifically on teaching English through online modes. The other 6.9% belonging to a 1C school in the Uva Province had undergone training specifically to teach English online and they have been facilitated at Zonal level.

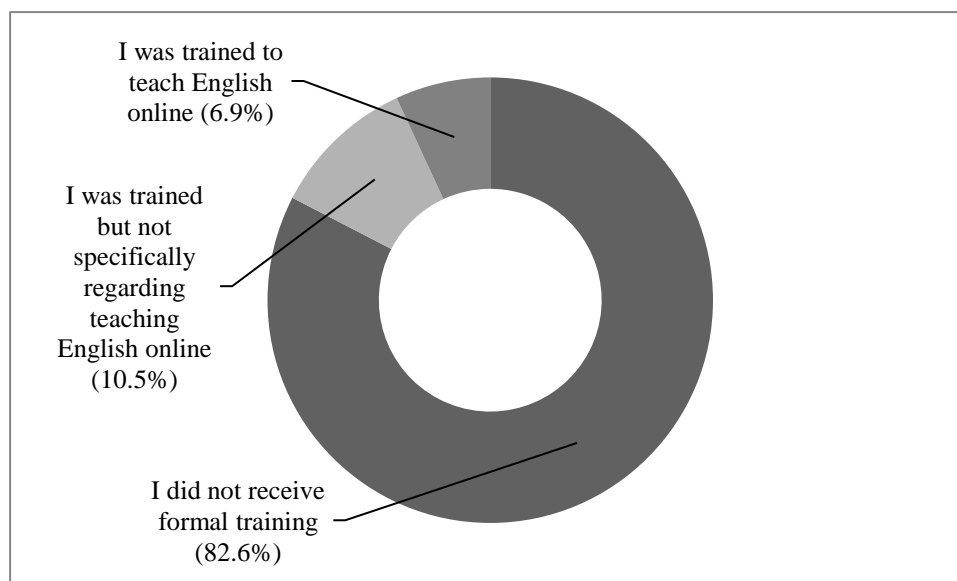

Figure 2: Formal Training Provided for ERT

Figure 3 illustrates the percentage of the teachers of English who received informal training to teach online remotely. According to the figure, 69.3% of the teachers of English in the sample who engage in ERT have received self-training to teach English via online by learning through the internet and by practice or experience. 11.5% of the participants have undergone training informally with a resource person at Provincial, Zonal, and Divisional level. 11.5% of the participants have received training informally from their fellow teachers. The least number of the participants, 7.7% have received training informally from their family members.

Except for a 6.4% of the participants, majority of them were not aware of special methodologies utilized to teach the four skills specifically through online modes.

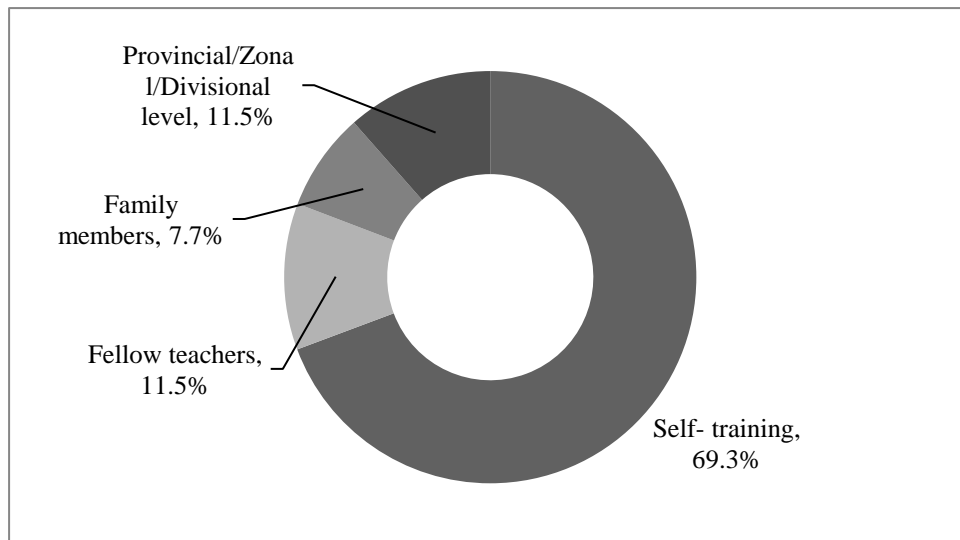

Figure 3: Informal Training Received by the Teachers of English

Table 1 shows the responses provided by the participants who have not received training of any nature on the necessity of formal training to teach English through ERT to make their teaching a success.

	Formal Training is Needed	%
1	Strongly agree	37.9
2	Agree	48.3
3	Neither agree nor disagree	6.9
4	Disagree	6.9
5	Strongly disagree	-

As depicted in Table 1, most of the teachers of English, 86.2% are in the view that formal training is needed for successful ERT of English. Although a minute percentage, 13.8% of the sample does not have a clear understanding of receiving formal training for ERT to teach English language successfully.

## 5. CONCLUSIONS AND RECOMMENDATIONS

In conclusion, the findings indicate that although two year have been passed since the outbreak of Covid19 and teachers are made to practice ERT, teaching English remotely in the Uva Province, Sri Lanka is still unsuccessful as there is a dire need for infrastructure for both teachers and students for successful implementation of ERT. Both teachers and students find difficulties in finding devices, proper network coverage, efficient teaching material etc. Poverty of students in the Province which has been hindering successful traditional education continues to be a major obstacle in introducing successful online teaching remotely. Moreover, teachers of English in the Province require sufficient formal training to teach online in general and to teach English specifically via online modes.

## REFERENCES

- Bozkurt, A. and Sharma, R.C., (2020). Emergency remote teaching in a time of global crisis due to CoronaVirus pandemic. *Asian Journal of Distance Education*, 15(1), pp.i-vi.
- Hodges, C.B., Moore, S., Lockee, B.B., Trust, T. and Bond, M.A., 2020. The difference between emergency remote teaching and online learning.
- Seabra, F., Teixeira, A., Abelha, M. and Aires, L., (2021). Emergency remote teaching and learning in Portugal: preschool to secondary school Teachers' perceptions. *Education Sciences*, 11(7), p.349.

- Hayashi, R., Garcia, M. and Maddawin, A., (2020). Online Learning in Sri Lanka's Higher Education Institutions during the COVID-19 Pandemic. Asian Development Bank.
- Bond, M., Bedenlier, S., Marín, V.I. and Händel, M., (2021). Emergency remote teaching in higher education: mapping the first global online semester. *International Journal of Educational Technology in Higher Education*, 18(1), pp.1-24.
- O'Keefe, L. R., (2020). Covid-19 and Emergency Remote Learning/Online Learning. *Online Learning and Distant Education*, 15.
- Sarma, V., Licht, S. and Kalugalagedera, T., (2018). Educational Inequalities in Sri Lanka: National Data and Local Perspectives on Access, Quality and Learning Outcomes.

# 'I Hate Online Classes': Challenges and Perceptions of Students on Online Learning

Suranmali Prananda\*

Department of English Language Teaching, University of Colombo, Sri Lanka

## ABSTRACT

*With the onset of the pandemic, the lecturers were requested by the university to continue English classes through an online mode. This study investigated the challenges students encountered and discussed their perceptions about a particular online course they joined. This course was conducted for two and a half weeks with 63 students joined from all over the island. To make the learning process interactive and interesting, e-resources such as Padlet, Linoit and breakout rooms were used. A questionnaire in Google form was sent to the students which included close and open ended questions. The findings showed that a majority of students had used their mobile phones to log in while some students had to share their device with a family member who was having classes simultaneously. Many had experienced connection problems or power failure. Some students had said that they like to continue online classes as it gave them an opportunity to communicate without being shy. In contrast, 68.3% said that they did not like online classes as they wanted to meet friends and see the lecturer face to face. Another student had mentioned that long hours of sitting looking at the mobile phone listening to lectures caused headache and backache which could lead to stress.*

**Keywords:** Challenge, Interactive, Online, Perceptions, Stress.

## 1. INTRODUCTION

Although English as a Second Language (ESL) teachers have been using multimedia in the classrooms, with the onset of the pandemic it moved to online learning or in other words, Emergency remote teaching (ERT) the world over. Similarly, the lecturers at the Department of English Language Teaching were requested to continue the English classes in an online mode. While online teaching and ERT both use technology, the definition of both differs. According to Hodges et al., (2020) 'Online learning and teaching means planned and well-designed method of instruction done using technology.' In contrast, ERT is addressed as 'a temporary shift of instructional delivery to an alternate delivery mode due to crisis circumstances' (Hodges et al., 2020).

## 2. SAMPLE

The sixty three participants in this study are from the Faculty of Arts, University of Colombo, who had scored marks between 36 – 49 at the placement test which is conducted when they enter the university.; They were students between the ages of 20-22 yrs. Majority of the students were female as seen in the Figure 1.

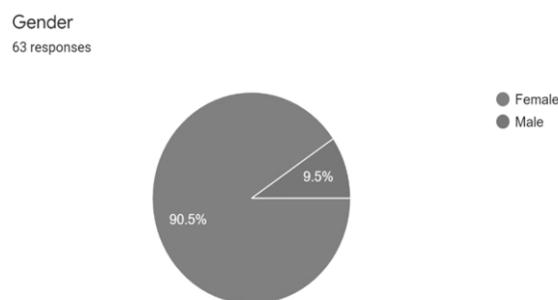

Figure 1: Gender

\* Corresponding Authors: Emails – [suranmalip@delt.cmb.ac.lk](mailto:suranmalip@delt.cmb.ac.lk)

### 3. A BRIEF OUTLINE ABOUT THE COURSE

Lessons which had been prepared to be delivered in an onsite mode had to be delivered online which was challenging for the ESL teacher. The modules were uploaded to the Learning Management System (LMS) for the students. This course was conducted for two and a half weeks and consisted students from all over the island.

The course consisted of five modules which had greetings and introductions, giving directions, giving and following instructions and numbers and shapes. As shown in Figure 2, a majority of students had enjoyed the lesson on giving directions. The lesson the students had least enjoyed was the lesson on numbers and shapes.

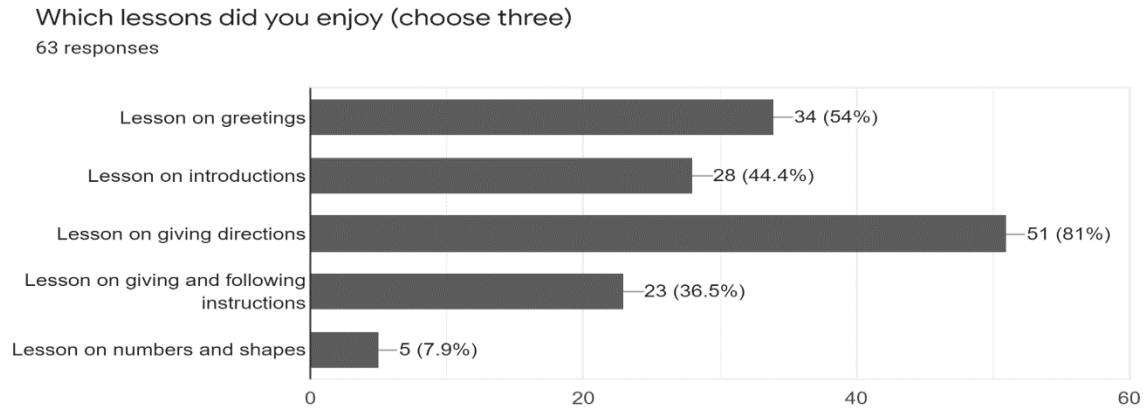

Figure 2: Lessons Enjoyed

#### 3.1. The Online Teaching Learning Process

The accepted norm is that a language class should be interactive, interesting and learner centered to facilitate learning. Many researchers (Piaget, 1969; Vygotsky, 1981) have mentioned the importance of interaction in the classroom. Further, Anderson (2003) states that ‘as student engagement is developed through interaction, fostering interaction in the classroom is an important consideration in ensuring that students actively create their own knowledge and reach a high level of achievement.’

Conrad and Donaldson (2004) observe that the learner studies in isolation in the online class. Hence it is important to create an interesting teaching environment which promotes interaction among the students. To create this interaction breakout rooms, chat storm and e-resources such as Padlet and Linoit were used. As majority of the students logged in with their mobile phones, the interactive activities had to suit the devices used by the students together with the connection issues they



Figure 3: Padlet

encountered. For instance, Huawei phone users cannot use Google docs. To teach giving and following instructions, breakout rooms and Padlet were used. First the students were put into breakout rooms and given time to discuss. They had to remember their group and accordingly worked on the Padlet, each group creating a recipe. After the completion of this activity feedback in the form of a peer review was

done where students from other groups wrote their comments on the Padlet. Hence, this activity promoted interaction as well as collaborative learning. Figures 3 and 4 depict a Padlet and a Linoit.



Figure 4: Linoit

It was the first time a majority of the students had used Padlet and Linoit as seen from Figures 5 and 6 below.

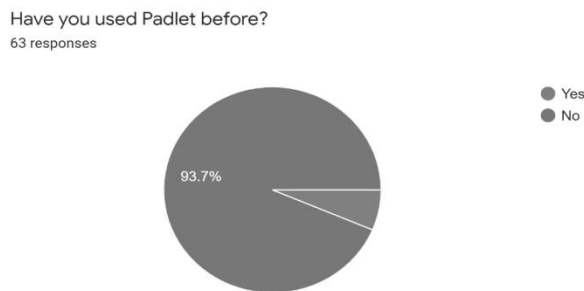

Figure 5: Used Padlet before

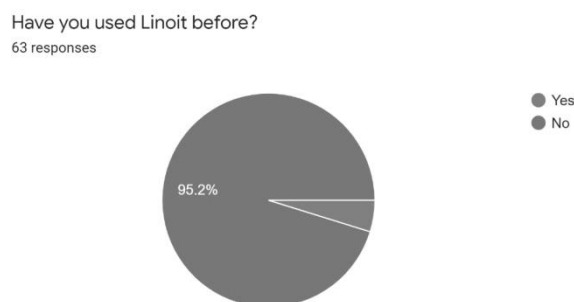

Figure 6: Used Linoit before

#### 4. A BRIEF DESCRIPTION OF THE CHALLENGES ENCOUNTERED BY THE STUDENTS WHEN STUDYING ONLINE

Majority of the students had logged in using their mobile phones from their homes. Some had used their laptops as seen in Figure 7.

What device did you use to log in for the class?  
63 responses

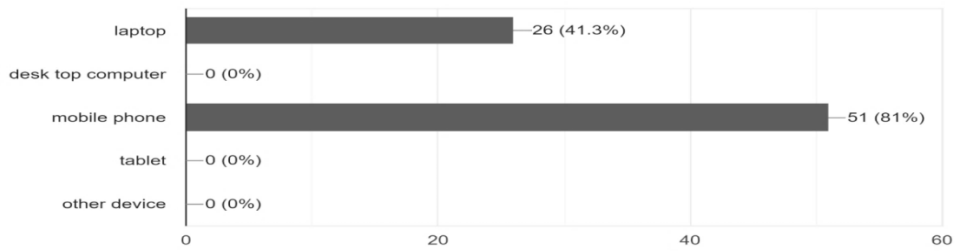

Figure 7: Device Used to Log in to the Class

#### 4.1. Sharing Devices

Some had to share their devices with their family members as seen in Figure 8. They had to share their devices with sisters, brothers and parents as seen from the comments given below.

Did you have to share your device with your parent / sister / brother who was having their classes at the same time as your class?  
63 responses

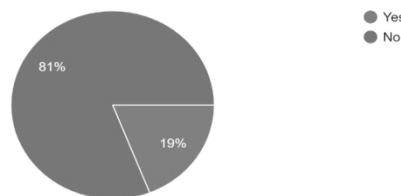

Figure 8: Shared the Device

- ‘My sister has a class on Friday from 2pm – 4pm. I have FND 1104 lecture from 2pm-3pm. I listen to the recording on LMS.’
- ‘We have only two devices. My brothers also have classes at the same time, so we have to share the devices.’
- ‘My mother also has zoom classes. Both of us have only one device.’
- ‘I have two school going sisters. Sometimes we all have classes at eth same time. Then it’s difficult to join lectures.’
- ‘We have only two smart phones. There are five children in my family. I am the eldest.’

#### 4.2. Connection Problems / Power Failure

Some had experienced power failure as seen in Figure 9.

Did you experience connection problems / power failure while attending the class?  
63 responses

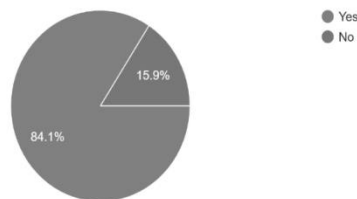

Figure 9: Experienced Connection Problems / Power Failure



### 5. STUDENTS' PERCEPTIONS REGARDING ONLINE CLASSES

As seen in Figure 10, a majority of the students prefer onsite classes while some have said they prefer online classes.

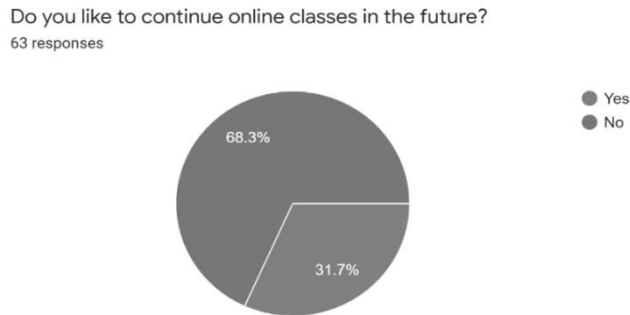

Figure 10: Students Who Like and Dislike Online Classes

Given below are some student responses for online classes. The responses have been categorized according to the following as shown in Table 1.

Table 1: Responses for Online Classes

Item coding	Responses
<b>Opportunity to improve computer knowledge</b>	<ul style="list-style-type: none"> <li>- Before I did not know about online system, so in this session I understand lot of techniques (breakout rooms, how to type using Padlet, Linoit)</li> <li>- Improves our computer knowledge</li> <li>- Can get technical knowledge</li> <li>- Easy to understand, useful for our knowledge.</li> </ul>
<b>Opportunity to improve communicative ability</b>	<ul style="list-style-type: none"> <li>- Gives an opportunity for us to communicate with each other without being shy.</li> </ul>
<b>Save time and learn from home</b>	<ul style="list-style-type: none"> <li>- Can save time</li> <li>- Can learn from home</li> </ul>
<b>Using e-resources</b>	<ul style="list-style-type: none"> <li>- We like to work with Padlet and Linoit. It is very colorful and attractive.</li> </ul>

Given below are some student responses against online classes. The responses have been categorized according to the following as shown in Table 2.

Table 2: Responses against Online Classes

Item coding	Responses
<b>Sharing devices / dislike online classes</b>	<ul style="list-style-type: none"> <li>• Difficult, have to share device with sisters when classes at the same time.</li> <li>• I don't like online classes</li> <li>• I don't like this online education because it is very difficult for us.</li> </ul>
<b>Stress and health issues</b>	<ul style="list-style-type: none"> <li>• Lectures the whole day on some days 7-8 hours with assignments. No time to eat and drink. I get headaches looking at the phone for a long time. Pain in the eyes. Very difficult to sit in one place for a long time. I like to come to university and study with my friends.</li> </ul>

---

*Now I have to stay in the room alone and look at the screen. No time to enjoy free time with my family. I will get stressed if we continue like this. I hate online classes.*

**Connection / signal issues**

- *We don't see others' faces. Sometimes we don't talk in breakout rooms because of signal issues.*
- *When I face signal problems while using zoom I miss many lessons.*
- *It is not comfortable. Can't understand the lesson after reconnecting.*

**Socialize experience university life**

/

- *It's boring to have lectures all the time through zoom.*
  - *I like to study onsite.*
  - *I like to learn onsite with my new friends.*
  - *I would like to come and learn at the university. It is better than online learning.*
  - *I like to meet all friends and lecturers onsite. It will also motivate our studies.*
  - *I want to experience university life.*
  - *As a university student I like to get experience of the university and want to chat and get to know my friends. Also we like onsite lectures. Zoom lectures are very boring and we feel sad. We want to come to university and get university experience.*
- 

**6. CONCLUSION**

The data show the challenges experienced by the ESL teachers and the students working in the new normal. As this pandemic is here to stay for another few years, it is important that some measures be taken to find ways of assisting students who are facing difficulties. Moreover, the teaching staff should be innovative and find interesting and interactive methods to teach in a virtual environment.

**REFERENCES**

Anderson, T., (2003). Modes of interaction in distance education: Recent developments and research questions. *Handbook of distance education*, pp.129-144.

Conrad, R.M. and Donaldson, J.A., 2004. *Engaging the online learner: Activities and resources for creative instruction*. San Francisco, California: John Wiley & Sons, Inc.

Hodges, C.B., Moore, S., Lockee, B.B. et al. (2020). The difference between emergency remote teaching and online learning.

Piaget, J., 1969. *The mechanisms of perception*. London. Routledge & Kegan Paul.

Vygotsky, L.S. (1981). The genesis of higher mental functions. In J. V. Wertsch (Ed.). *The concept of activity*. Armonk, New York.

# Impact of Cultural Affinity on Foreign Language Learning

J. C. Munasinghe\*

University College Matara, Sri Lanka

## ABSTRACT

*The present study examines the relationship between learning a foreign language and its cultural affinity by referencing the research conducted and examining several concepts regarding language and culture. Furthermore, most of the research conducted on the topic has stated that the ignorance of cultural affinity hinders language learning competencies. Finally, the study will present recent theories in the existing literature to show the relationship between language and culture. Through the study, it has been revealed that the knowledge of culture acts as an impactful factor in determining foreign language learning competencies.*

**Keywords:** *Cultural Affinity, Foreign Language Learning, Language Learning Competencies.*

## 1. INTRODUCTION

Culture is deeply embedded in the fundamental fabric of our being. Language, as a medium of communication among members of a culture, remains the most visible and accessible form of expression. (Brown, p.170, 2000). Many scholars have identified the intimate nature of the language and its culture. Utilization of language also involves the utilization of social and cultural values. Consequently, ignorance of the social and cultural values and norms related to a particular language may hinder communication and the use of that language. (Bateman, 2002). Moreover, when the teachers do not incorporate culture in their lessons, the students lack an important component of the language learning process, and their level of motivation can also be affected. LoCastro (2001) Thus, the culture facilitates and motivates the student for better proficiency in a language. To help students learn and teach languages, Hardley, Reiken and Kramersch examine various aspects of culture, including its relationship to civilization, how it connects to the exotic versus the commonplace as well as how it might be a collection of facts or an inventory. (Hadley and Reiken 1993, p.450; Kramersch 1993, p.206) However, relatively little research has been conducted in the Sri Lankan context on foreign language learning and its cultural affinity. Therefore, the present study makes allusions to the researchers conducted outside the Sri Lankan context. Also, this study evaluates how the researchers perceived the concept of culture over a while in the past and the recent articles on cultural affinity and language learning. (Risager, 2007).

## 2. THE INDEPENDENCE OF LANGUAGE AND CULTURE

Language does not exist, according to some social scientists, without culture. As a result, language is both a product of and an expression of the social institutions in which we live and work. Culture is defined as the social framework of a group. According to Fairclough (1989: vi), formalized language and culture, "Learning a language apart from its cultural counterparts precludes avoid one from socializing into the contextual utilization." According to Ned Seelye, Language structure alone does not provide unique insight into the political, social, religious, or economic systems (Seelye,1984). All of the experts agree that simply learning a language does not guarantee that the student will be fluent in it. However, in the traditional view of culture and language, the culture is separated from the language. (Nostrand, 1989). As Lessard-Clouston points out, people in the past were eager to master a foreign language to study the works of foreign authors. Students were able to learn about the culture linked with the target language through reading. (Lessard-Clouston 1996). In the 1960s and 1970s, scholars such

---

\* Corresponding Author: E-mail - [jayogha@ucm.ac.lk](mailto:jayogha@ucm.ac.lk)

as (Hall and Hall 1959), (Nostrand 1989), (Seelye 1984), and (Brooks 1968) tried to establish a relationship between the language and the culture so that, for the language learner, the other culture would be less intimidating and more approachable. (Kramsch, 1993, p. 224). At the time, we used the audiolingual methods (Brooks 1968) 'stressed the relevance of culture', For the study of language, not literature, even though the cultural affinity of language was recognized since the beginning of the 20th century, it was not used in language courses. It was not evident to the students or the teachers. However, the linguists were aware of the importance of culture in the teaching of a language and the impossibility of learning a language without culture (Kaya 2021)." There is, unfortunately, lack of link between language acquisition and cultural education for many pupils" (Bateman 2002). This unawareness of the culture made them encounter many difficulties since the culture influences the language.

However, recent linguists have recognized and cooperated on culture in language teaching. "Culture is language, and language is culture." Tang (1999). Many ethnographers, including Buttjes (1990), Ohchs and Schieffelin (1984), and Peters and Boggs (1986), have tried to demonstrate that "language and culture are inextricably linked from the beginning" (Buttjes, 1990, cited in Lessard-Clouston, 1997). Buttjes also claims that language instruction is cultural instruction. Teachers of foreign languages must be aware of the complex and variable intercultural mediation processes that each foreign language learner go through (Buttjes, 1990). Therefore, it is evident how much culture can facilitate students' learning a foreign language.

### **3. CULTURE AND COMMUNICATION SKILLS**

Knowledge of culture as a foundation for communication has long been recognized and discussed. Ignorance of some cultural aspects of the language hinders effective communication." Many scholars have emphasized the relationship between communication and culture. "Learning to master extra language" entails "developing a knowledge of how culture interacts with language whenever it is employed," according to (McLaughlin and Liddicoat 2005). grammatical, sociolinguistic, discourse, and strategic abilities are all components of communicative competence, (Canale and Swain 1980), is a broad word that is insufficient in part unless it is accompanied with intercultural competencies. This approach has also been applied to social psychology and communication research (Wisemar and Koester, 1993, cited in Chen 1997). Van Ek's model of 'communicative ability (1986), cited in Byram (1997), comprises six' competencies. Of these competencies, two (social competence and socio-cultural competence) are directly linked to culture.

The inability to understand a particular culture related to a language lead to "negative cultural transfers" in communication. As a result of cultural differences, people subconsciously use their cultural norms and ideals to influence their own conduct as well as to critique the behavior and thoughts of others. Negative cultural transfer defines this interference. (Wei, 2009). The concept of negative cultural transfers was immersed in the field of linguistics in the 1950s. In his book "Linguistics across cultures", Robert Lado states that negative cultural transfers are a barrier to language learning. Kramsch pointed out that the understanding of socio-cultural values of the target language is important in communicating in that language (Kramsch, 1993). He further stated that mastery of a language alone does not become helpful in ensuring effective communication. According to him, mere mastery of language without socio-cultural knowledge creates conflicts and difficulties in learning the language and even hatred among nationalities. "[c]ulture is a struggle between groups occupying distinct, sometimes opposing, locations on the map of social relations, not a generally harmonious and stable pool of significations" (Kramsch, 1993).

### **4. CULTURAL SCHEMATA OR THE THEORY OF SCHEMA**

There are many definitions of the concept of schema. The schema, for example, is described as the process through which new information is gathered and processed. Pre-existing or pre-existing knowledge is the subject of this study. Asmari and Javid (2018) define Cultural schemata are one type of schemata helpful in foreign language learning and formal schemata, linguistic schemata and content schemata. However, Gudykunst (2005) summarizes existing literature of cultural schemas in his book

“Theorizing about Intercultural Communication” as follows: “Cultural schemas are produced and retained in our brains when we engage with individuals of the same culture in certain situations or talk about certain material with them multiple times. The cultural schemas grow more ordered, abstract, and compact as we meet more identical scenarios or talk about the material more frequently. People build cultural schemas as a result of their firsthand experiences as well as discussions regarding cultural schemes”. (Gudykunst 2005, p.403)

As the definition itself reveals, cultural schemas facilitate language learning. Thus, if a student forms a cultural schema due to his cultural knowledge of the language, it facilitates his linguistic and communicative competency.

Schema theory is also important in a wide range of fields, including communication and education. When people utilize schemas in different ways, it's simple to misinterpret each other. People may misunderstand when someone says "I like riding" in reference to a horse, thinking instead that they mean "I like cycling! (Landry, 2002). The Dictionary of Cultural Literacy was released by Hirsch and colleagues in 1989 as a reference book for English language learners who wished to expand their knowledge of American culture. Many scholars have emphasized the importance of creating cultural dictionaries and thereby creating a linguacultural environment.

## 5. THE LANGUACULTURE OR LINGUA CULTURE CONCEPT

Contrary to the view that language and culture are inseparable, some scholars have argued that language and culture can be separated. Separability of the language and culture is a recent view emphasized, especially in learning English as a foreign language. However, in today's globalized world, English serves as a common language and is also implicit in the CLIL method (Content and Language Integrated Learning). Math and science are two areas that make extensive use of the target language. In those instances, the use of language in communication is not considered important and thereby refuses the social and cultural counterpart of the language. However, criticizing the view that language and culture are separable, language culture or linguacultural was introduced. It mainly carries the idea that language carries the counterpart of culture. The American linguistic anthropologist Michael Agar has developed this concept. Agar defines *language* as "the necessary tie between language and culture. According to Agar, there are two parts of language culture: source languaculture and target languaculture. Moreover, Agar points out some "rich points" in languages. According to language culture, a language cannot be separated from culture, and language does not exist without culture (Agar ,2006). However, subsequent research gave different interpretations of the concept of languaculture.

According to Risager (2007), a person's “linguacultural identity can be isolated from their language, although language is never truly neutral.” According to him, linguacultural means the language carried by the culture, even when the person speaks a language lives in a different culture from the target culture. He further states that the relationship between language and culture has taken on a different perspective by introducing globalization and multicultural societies. (Risager 2007, p. 201). His main point in the concept of language culture is that language carries culture wherever it goes. However, the subsequent studies further stressed the empirical studies of language and culture, thereby proving the inseparable nature of language and culture.

## 6. CONCLUSION

The present study aims at evaluating different concepts in recent literature on learning languages and cultural affinity. By referring to most of the studies conducted on the cultural counterpart of language learning, it is an evident fact that the language and culture are inseparable and cannot be separated. Therefore, language competencies acquired and cultural affinity will be immensely supportive in language learning, specifically in the context of foreign language learning, where the learner is completely ignorant of the target language's culture. Also, many types of research have proved that the ignorance of the cultural counterpart of a foreign language will create barriers in communication.

## REFERENCES

- Agar, M. (2006). Culture: Can you take it anywhere? Invited lecture presented at the Gevirtz Graduate School of Education, University of California at Santa Barbara. *International journal of qualitative methods* 5(2), pp. 1–16.
- Al Asmari, A. and Javid, C.Z. (2018). Role of content schema in reading comprehension among Saudi EFL students: EFL teachers' perspective and use of appropriate classroom strategies. *International Journal of English Linguistics* 8(4), p. 96.
- Bateman, B.E. (2002). Promoting openness toward culture learning: Ethnographic interviews for students of Spanish. *The Modern Language Journal* 86(3), pp. 318–331.
- Brooks, N. (1968). Teaching culture in the foreign language classroom. *Foreign language annals* 1(3), pp. 204–217.
- Brown, H.D., (2000). *Principles of language learning and teaching* (Vol. 4). New York: Longman.
- Buttjes, D. (1990). Teaching foreign language and culture: Social impact and political significance. *Language Learning Journal* 2(1), pp. 53–57.
- Canale, M. and Swain, M. (1980). Theoretical bases of communicative approaches to second language teaching and testing. *Applied linguistics* 1(1), pp. 1–47.
- Chen, G.-M. (1997). A review of the concept of intercultural sensitivity.
- Fairclough, N. (2014). *Critical language awareness*. Routledge.
- Gudykunst, W.B. (2005). *Theorizing about intercultural communication*. Sage.
- Hadley, A.O. and Reiken, E., (1993). *Teaching Language in Context, and Teaching Language in Context--Workbook*. Heinle & Heinle Publishers, International Thomson Publishing Book Distribution Center, 7625 Empire Drive, Florence, KY 41042.
- Hall, E.T. and Hall, T., (1959). *The silent language* (Vol. 948). Anchor books.
- Kaya, S., (2021). From Needs Analysis to Development of a Vocational English Language Curriculum: A Practical Guide for Practitioners. *Journal of Pedagogical Research*, 5(1), pp.154-171.
- Kramsch, C. (1993). *Context and culture in language teaching*. Oxford university press.
- Lessard-Clouston, M. (1996). ESL vocabulary learning in a TOEFL preparation class: A case study. *Canadian Modern Language Review* 53(1), pp. 97–119.
- LoCastro, V. 2001. Individual differences in second language acquisition: Attitudes, learner subjectivity, and L2 pragmatic norms. *System* 29(1), pp. 69–89.
- McLaughlin, M. and Liddicoat, A.J. (2005). Teachers' professional learning: in the context of intercultural language learning. *Babel* 40(1)
- Nostrand, H.L. (1989). Authentic texts and cultural authenticity: An editorial. *Modern Language Journal*, pp. 49–52.
- Ochs, E. and Schieffelin, B. (1984). Language acquisition and socialization. *Culture theory: Essays on mind, self, and emotion*, pp. 276–320.
- PETERS, A. and Boggs, S.T. (1986). Influences upon language acquisition. *Language socialization across cultures* (3), p. 80.
- Risager, K. (2007). *Language and culture pedagogy*. Multilingual Matters.
- Seelye, H.N. (1984). *Teaching Culture. Strategies for Intercultural Communication*.
- Tang, R. (1999). The place of" culture" in the foreign language classroom: A reflection. *The Internet TESL Journal* 5(8), pp. 1–2.
- Wei, X. (2009). On negative cultural transfer in communication between Chinese and Americans. *Journal of Intercultural Communication* (21)

# Impact of Formative Assessment Mode on Summative Assessment of Upper-Secondary School Students

M.M.N. Sarfa\* , S.A.N. Danushka

Department of Education and Training, University of Vocational Technology, Ratmalana, Sri Lanka

## ABSTRACT

*The diagnostic use of formative assessments fosters knowledge, skills, and attitudes of students and teachers or instructors and distinguishes their qualities and shortcomings. It stands as an opposite concept of summative assessments, which generally takes place as an ongoing process in schools. This study was carried out to outline the effect of formative assessments upon summative assessments of upper-secondary school students. It was a quasi-experimental study with controlled and experimental groups and Pre-Test/Post-Test design. The sample was selected according to the purposive sampling technique. It comprised 60 students in grade 10. The sample was divided into controlled and experimental groups equally. English subject was selected to teach them. The two groups were pre-tested before the treatment. The experimental group was instructed and evaluated with three types of formative assessments selected from the literature review and the controlled group was free from the treatment. In the end, a post-test was conducted for both groups. Pre-test and post-test were identical. The first objective was achieved from the literature review and types of formative assessments which enhance classroom learning were identified. The results of the tests conducted were analysed using correlation, t-test, and Cohen's d. This study concluded that formative assessments increase the scores of summative assessments of upper-secondary school students.*

**Keywords:** English language learning, Experimental design, Formative assessment, Student achievements, Summative assessment.

## 1. INTRODUCTION

Today students face a changing and challenging world that demands new knowledge, skills and attitudes. In the 21<sup>st</sup> century, students should acquire the capacity to analyse, make inferences, and think critically and creatively. Education is considered as the most important process which makes the students face the society and world. To make the process of education more effective, interesting and efficient, assessment procedures are being introduced. The assessments are conducted and done with the participation of teachers, students and parents. Black and William (1998, p.7-74) defined assessments as all those activities undertaken by teachers, and/or by their students, which provide proper data to be utilized to change and improve the exercises and activities involved in the process of teaching and learning.

Assessment can be categorized into different types concerning their applications. Particularly, formative and summative assessments take a prominent place in the process of teaching and learning. Formative assessment is also called an “*assessment for learning*”. Formative assessment is an interaction that sets out open doors to advance the improvement of students’ abilities of clarifying, deciphering and thinking (Bulunuz et al., 2016, p.33-50). Formative assessment is done while the course or programme is ongoing. Summative assessment involves the process of grading the results over a while, and checking-up by testing learning at a particular time (Linn, 2000).

The results obtained from two experimental research studies directed by Fontana and Fernandes (1994, p.407-417) give a clear picture of the students who understand about the learning objectives and assessment criteria and have opportunity to consider their work, show higher improvement in their studies than the students who do not. Formative assessments improve pedagogical practices of teachers and it provides support and feedback to lower-performing students about their current performance (Dunn and Mulvenon, 2009, p. 1531-7714). Reviewing around 250 articles by Black and William (1998) regarding formative assessment, expressed that the conclusion derived from all those articles showed,

---

\* Corresponding Author: E-mail - [nusrathsarfa@gmail.com](mailto:nusrathsarfa@gmail.com)

formative assessment fosters the process of learning and the enhancement of students' academic performances were high. Formative assessment is not only a separate activity which occurs during the period of instruction or course but also a coordinated part of the process of education. It acts as a catalyst in the improvement of students' academic achievements and helps teachers to modify and enhance their teaching methodologies. This study investigates how formative assessment impacts summative assessment of upper-secondary school students.

### 1.2. Objectives of the Study

1. To find out the types of formative assessments that can be used to enhance classroom learning.
2. To identify the relationship between the results of formative and summative assessments.
3. To find out the impact of formative assessment upon the performance of summative assessment.

## 2. LITERATURE REVIEW

Various types of formative assessment allow students to experience and enjoy the process of learning and improve their performances. Formative assessment does improve student learning but there are set of various formative assessments which enhance classroom learning.

The Ministry of Education – MoE (2008) has issued a booklet which presented 23 modalities of SBA to be utilized in the classrooms from grade six to Thirteen. It has included projects, role-plays, assignments, instant speeches, surveys, panel discussions, discoveries, debates, observations, quiz programs, demonstrations/presentations, wallpaper, field trips, double-entry journal, short written tests and structured essays, concept maps, open-book tests, group activities, creative activities, collection of own creations, listening, speech, and practical activities.

Bandara (2014) studied 23 different types of assessments and confirmed that the most used type of SBA in grade 11 was short written tests and it was used for science subject (90% of the teachers used this type of assessment). Short written test was the most common formative assessment technique used by the teachers frequently. It was observed that 70% of teachers preferred group works and practical tests in the classrooms as second and third assessment techniques. All the other techniques of formative assessment introduced in the booklet of 2008 presented by Ministry of Education has received less than 30% of rating and a few assessments such as speech, presentations, and projects received 20% of rating.

Varieties of formative assessment allow students to measure their competency level with scores and identify their strengths and weaknesses and provides constructive feedback about their current level in the studies. The most common assessment practices are paper-pencil tests, homework assignments, tests and projects. Classroom discussions and Group activities have a greater positive impact on student achievement than other types of formative assessment (Black and William, 1998, Mehmood et al., 2012, Ministry of Education, 2008). Other types of formative assessment like short written tests (Black and William, 1998, Weurlnder et al., 2012, Ministry of Education, 2008), portfolios or collection of student work (Bandara, 2014, Duschl and Groomer, 1997, Ministry of Education, 2008) also have greater gains in students' academic achievements. These are the most recommended types of formative assessments in the studies done earlier.

## 3. RESEARCH METHODOLOGY

The present study was a quasi-experimental study where pre-test and post-test were implemented for both control and experimental groups.

Figure 1 shows the research design which consists of the sample, procedure of the study and the treatment followed in the study.



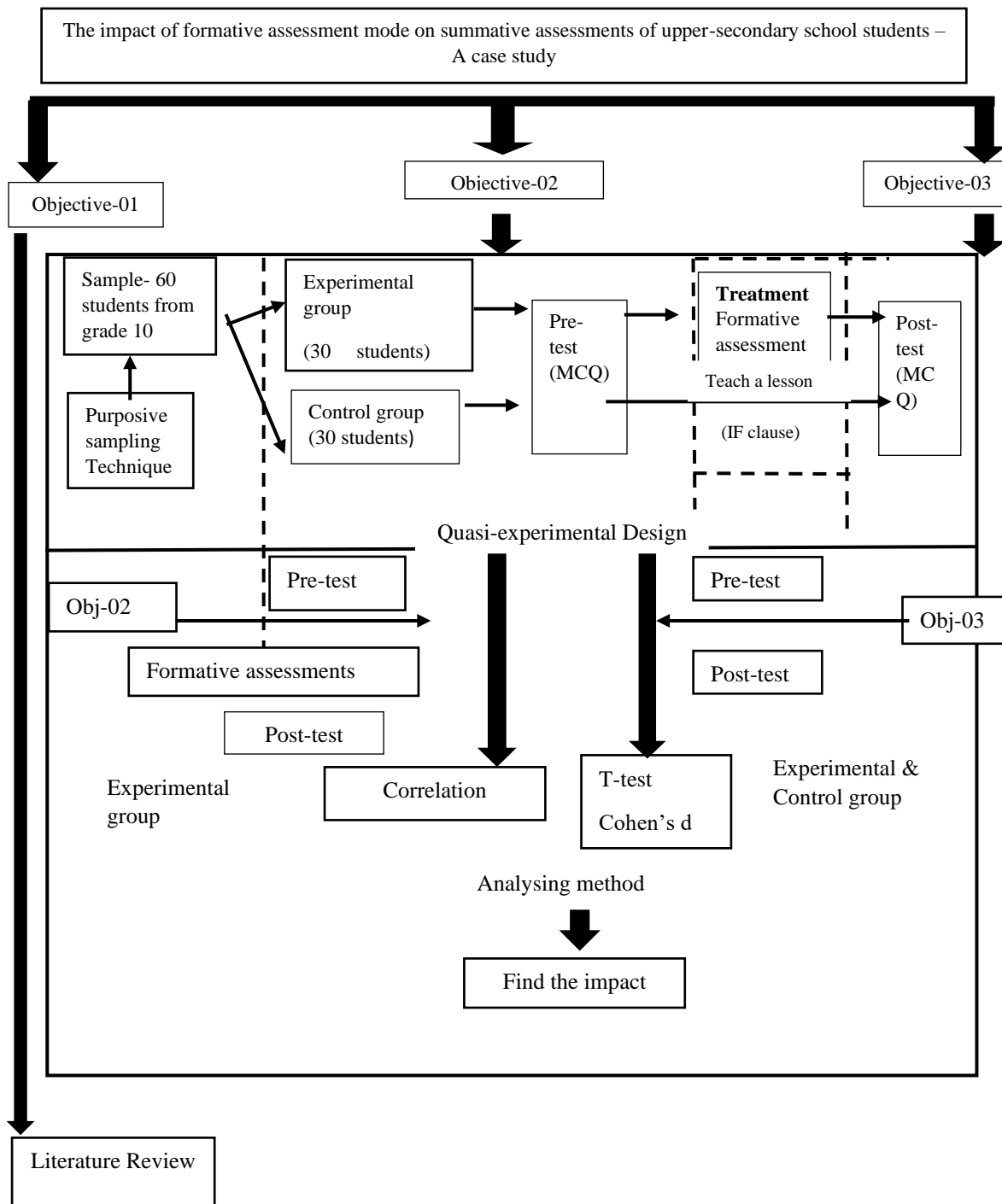

Figure 1: Research Design

### 3.1 Sample of the Study

In this study, the population consisted of all the grade 10 students studying at AK/Addalaichenai National School. A sample of 60 students was selected out of 218 students from grade 10 classes in AK/Addalaichenai National School by using the purposive sampling technique.

### 3.2 Procedure of the Study

The study used a Pre-test/Post-test design. The sample of 60 students was made into control and experimental groups equally. The two groups were pre-tested to find out the competency level before teaching the lessons (treatment). The experimental group was instructed and evaluated with three types of formative assessment as a treatment while the control group was free from it. Post-test was conducted

on both control and experimental groups after the completion of the lesson (treatment). Pre-test and Post for both groups were developed in the subject of English. Both pre-test and post-test were identical and consisted of 10 MCQ questions with 30 minutes time duration. Aligning to the literature review, three effective formative assessment techniques for English language learning were selected. Then statistical techniques such as correlation, t-test and Cohen's d were employed to analyse pre-test and post-test data.

### 3.3 Treatment

Three different formative assessments - short written tests, homework and group discussion - were used to measure the performance of the experimental group. Unit 13 was selected in the grade 10 textbook. Unit 13 consisted of 'If clause conditional' as a grammar part. Totally seven days were selected for delivering the lesson. On the first day, both groups were pretested and an introduction was given about 'if clause type I'. The next day also type I conditional was taught and each type was taught for two days for both groups. On the seventh day, a post-test was given to both groups. Formative assessments were given to the experimental group while the instruction is going on. Three formative assessments were given for type I, II and III conditionals (One formative assessment for each type). Previous studies affirm that the afore-mentioned procedures could support effective and accurate results and conclusions (i.e. Bandara, 2014, Noonan and Duncan, 2005). The Control group was free from formative assessments.

## 4. RESULTS AND DISCUSSION

### 4.1. Research Objective - 1

Empirical studies provide ample evidence regarding the effectiveness of formative assessments which can be used to enhance classroom learning (Dunn and Mulvenon, 2009, Ayala et al, 2008, Noonan and Duncan, 2005, Bandara, 2014, Weurlander et al., 2012). There were 34 types of formative assessment identified from the review of the literature. There are kinds of formative assessment that have been highly recommended by researchers such as oral assessment, short written test, peer assessment, portfolio, group activities, Homework, etc. Some studies report new types of formative assessment to enhance classroom learning. For example, Web-based quiz-game-like formative assessment system (GAM-WATA) (Wang, 2007, p. 1247-1263) and Individual written tests which include factual questions and problem solving assessments (Weurlander et al., 2012, p.747-760). Based on the literature review conducted in the present study, three formative assessment techniques (short written test, homework and group discussion) were selected test to their effectiveness and impact on students' summative assessments.

### 4.2. Research Objective - 2

Table 1: Analysis of Experimental Group

Test Items	Group	Correlation	R <sup>2</sup> Value
Short Written Test and Post-test	Experimental	0.362	0.1311
Homework and Post-test	Experimental	0.077	0.0059
Group Discussion and Post-test	Experimental	0.144	0.0206
Pre-test and Post-test	Experimental	0.038	0.0014

It can be observed a relationship between Formative assessment techniques (Short Written Test, Homework, and Group Discussion) and summative assessment (Post-Test). Correlation tests show a positive relationship with each other. The first three correlation test results in Table 1 shows greater positive values than the fourth correlation test results obtained between Pre-Test and Post-Test of the experimental group, i.e., Formative assessment has a positive relationship with summative assessment.

Table 2: T-Test Analysis of Both Experimental and Control Group

Test Items	Group	Mean	Df	P(two-tail)
Pre-test	Experimental	60.33		
Pre-test	Control	59.66	56	0.89
Post-test	Experimental	92.67		
Post-test	Control	70.67	41	3.32E-06

The difference between the mean values of Post-Tests is greater than the difference between the mean values of Pre-Tests. Here, the mean value becomes a shred of major evidence for the impact of formative assessment on the summative assessment of the experimental group. The P-value of Pre-tests is 0.89. Therefore, it is higher than the standard value. And the P-value Post-Tests is 3.32E-06 (see Table 2). It is less than the standard value (typically  $p < 0.05$ ). The smaller the P-Value, the stronger the relationship between the two variables. There is a positive relationship between tested formative assessment (treatment) and summative assessment.

### 4.3 Research Objective - 3

Table 3: Cohen's d Analysis for Both Groups

Test Items	Group	Standard Deviation	Pooled SD	Cohen's d
Post-Test	Experimental	9.44	5.85	1.387
Post-Test	Control	20.33		
Pre-Test	Experimental	16.7		
Pre-Test	Control	20.4	18.65	0.035

The magnitude of impact size of pre-tests is 0.035 as per Cohen's d formula. If the impact size is less than 0.2, then there is a small effect or no impact between the two variables (Cohen, 1988). So, there is no significant impact between the pre-test of both experimental and control groups. The impact size of the Post-test is 1.3879 as per Cohen's d formula (see Table 3). Here the impact size is above 0.8, so the two variables have a strong impact on each other. At last, the results of this analysis indicate that formative assessment (treatment) has a positive impact on summative assessment (post-test).

As per the first objective of the study, the finding from the literature review provides many types of formative assessments that enhances classroom learning and was found out according to the number of studies that suggested the particular type of formative assessment. As per the second objective of the study, it was found out that both formative and summative assessment has a positive relationship with each other i.e. if the score of formative assessment increases, the score of summative also increases. As per the third objective of the study, the formative assessment has a positive impact size on summative assessment. Overall study findings say that formative assessment has a positive impact on the summative assessment of the students selected in the case study.

## 5. CONCLUSION

Formative assessment mainly focuses on the performance of summative assessment of students in various educational institutions. In some contexts, summative assessment is given priority in the teaching-learning process. This study was undertaken to find whether the formative assessment procedures are significant to enhance the methods involved in the education process. The results of the study brought out three conclusions such as some types of formative assessments can be used to enhance classroom learning, there is a positive relationship between formative and summative assessments, and Formative assessment does impact the summative assessment of post-secondary

school students. Therefore, formative assessments need to be prioritized and due recognition should be paid to enhance the students' performance in summative assessments.

## REFERENCES

- Ayala, C. C., Shavelson, R. J., Ruiz-Primo, M. A., Brandon, P., Yin, Y., Furtak, E. M., et al., 2008. From formal embedded assessments to reflective lessons: The development of formative assessment suites. *Applied Measurement in Education*, 21(4), 315–334.
- Bandara, J.M.R.I., 2014. *Enhancing Eleventh Graders' Understanding of "Different Solvents and Their Applications" Using School-based Assessment (SBA)*. Thesis (M.Sc). Postgraduate Institute of Science, University of Peradeniya.
- Black, P. and Wiliam, D., 1998. Assessment and Classroom Learning. *Assessment in Education*, 5(1), 7-74.
- Bulunuz, N., Bulunuz, M., Karagoz, F., and Tavsanli, O.F., 2016. Achievement levels of middle school students in the standardized science and technology exam and formative assessment probes: A Comparative study. *Journal of Education in Science, Environment and Health (JESEH)*, 2(1), 33-50.
- Cohen, J., 1988. *Statistical power analysis for the behavioural sciences*. 2<sup>nd</sup> ed. Hillsdale: Lawrence Earlbaum Associates.
- Dunn, K.E. and Mulvenon, S.W., 2009. A Critical Review of Research on Formative Assessments: The Limited Scientific Evidence of the Impact of Formative Assessments in Education. *Practical Assessment Research & Evaluation*. 14(7), 1531-7714.
- Duschl, R.D. and Gitomer, D.H., 1997. Strategies and challenges to change the focus of assessment and instruction in science classrooms. *Educational Assessment*, 4(1), 37-73.
- Fontana, D. and Fernandes, M., 1994. Improvements in mathematics performance as a consequence of self-assessment in Portuguese primary school pupils. *British Journal of Educational Psychology*, 64(3), 407-417.
- Linn, R.L. and Gronlund, N.E., 2000. *Measurement and assessment in teaching*. 8<sup>th</sup> ed. Upper Saddle River: Prentice Hall.
- Mehmood, T., Hussain, T., Khalid, M., Azam, R., 2012. Impact of Formative Assessment on Academic Achievement of Secondary School Students. *International Journal of Business and Social Science*. 3(17), 101-104.
- Ministry of Education., 2008. *School-based Assessment for Grades 6-13*. Battramulla, Isurupaya: Ministry of Education Sri Lanka.
- Noonan, B. and Duncan, C.R., 2005. Peer and Self-Assessment in High Schools. *Practical Assessment, Research & Education*, 10(17).
- Wang, T., 2007. Web-based quiz-game-like formative assessment: Development and evaluation. *Computers & Education*, 51(2008): 1247-1263.
- Weurlander, M., Soderberg, M., Scheja, M., Hult, H., Wernerson, A., 2012. Exploring formative assessment as a tool for learning: Students' experiences of different methods of formative assessment. *Assessment and Evaluation in Higher Education*, 37(6), 747-760

# Online Teaching in ELT Class Room – A Survey on Government English Language Teachers of Sri Lanka

D.S. Premarathne, L.H.D.L. Ranasuriya\*

Department of Language Studies, University of Vocational Technology, Sri Lanka

## ABSTRACT

*Due to the COVID 19 pandemic, many educational institutes including government schools have been closed. Students and teachers were shifted from traditional learning to online education. This immediate shift has created a number of problems in the education system. This study investigates the different perceptions of school English teachers towards teaching English online. The study was carried out based on a survey method. The sample consisted of thirty government school teachers who were appointed to teach English in the Galenbidunuwewa education zone, the Anuradhapura district. Quantitative data for the study was collected through a Google form questionnaire. Charts and tables were used to analyze quantitative data. The findings of the study reveal that more than half of the participants have negative perceptions towards teaching English online during this pandemic period. The findings further reveal that lack of facilities, lack of knowledge on devices, and network issues are the biggest challenges teachers face in conducting online classes. Establishing digital classrooms in schools, providing training programs for teachers and students, providing high-quality internet coverage and, revising the syllabus introducing video and audio lessons are the proactive suggestions proposed by the study to reduce the challenges.*

**Keywords:** Covid-19, English, Online teaching, Perceptions, Traditional teaching.

## 1. INTRODUCTION

As a result of the COVID 19 outburst, several countries instantly implemented physical distancing regulations. The World Health Organization informed the countries to impose a lockdown regulation for areas with a high number of COVID-19 patients, so that the activities of all sectors of life are interrupted. After the announcement that the spread of COVID 19 was a 'pandemic', many countries undertook various prevention methods to minimize the spread of the disease, including lockdowns, restrictions on face-to-face learning in schools and other institutes, restrictions on long-distance travel and so on. Schools and private education institutes of the world were advised to switch from face-to-face learning to fully online learning. All learning activities such as discussions, training, exams as well as learning support tools must be in digital form so that students can be easily logged into the internet network. The Sri Lankan government also took action to lockdown several areas in the country and all the educational institutions have been closed since the inception of the pandemic in 2020. As a consequence of this learners of schools and other educational institutions have been adversely affected. Over 1.5 billion students worldwide are currently facing this severe condition. This study is an attempt to find out the perception of English teachers to bring out proactive suggestions to enhance the effectiveness of online education.

### 1.1. Research Questions

- i. What are the teachers' perceptions towards teaching English through online?
- ii. What are the proactive suggestions that can be adopted to uplift the effectiveness of online teaching?

### 1.2. Research Objectives

---

\* Corresponding Author: E-mail - [dilniranasuriya@gmail.com](mailto:dilniranasuriya@gmail.com)

- i. To identify the teachers' perceptions towards teaching English through online.
- ii. To propose proactive suggestions to uplift the effectiveness of online teaching.

### 1.3. Limitations of the Study

This study is mainly focused to investigate the perceptions of government English teachers towards online education, as well as this study proposes proactive suggestions to uplift the effectiveness of online education. This study was planned to be carried out only in the Galenbidunuwewa education zone with the participation of thirty (30) teachers as the sample. Therefore the sample size of the geographical area is significantly low to generalize the results of the study. This has happened mainly because of the limited accessibility as a result of the COVID 19 outbreak throughout the country. Moreover, this study is only focused on the perceptions of English teachers. This is also a big challenge to generalize the findings of the study.

## 2. LITERATURE REVIEW

Communication media has been the very cause for the improvements of distance learning. Destianingsih & Satria (2020) have also done a study to investigate the students' needs for effective English online learning during Covid-19. The results of the study revealed that there were several tools which are able to be used during online classes by considering both groups of students' and teachers' internet access. While Zoom application is the most effective tool that can be utilized in explaining the subject and as the virtual tool to replace face to face meeting, Google classroom and WhatsApp are used to share and submit the assignments. Due to the pandemic situation all over the world, this online teaching-learning procedure is really difficult for the teachers, especially for the teachers who work in schools that have been located in rural areas. Dogoriti (2010) has conducted a study to explore the attitudes of English teachers in primary education toward web-based ELT. The findings suggest that they have positive attitudes towards online education. Finally, this study provides more information about the potential of language acquisition through the Web-based learning. Important guidance is provided in order to develop successful online ELT websites.

Since the COVID-19 has built up many considerable challenges in the traditional school teaching and learning system, there was a desperate need globally for every government to incorporate online education into their education system. Priyadarshani & Jesuiya (2021) stated that students are satisfied with online classes and get ample teacher help, but they do not assume that conventional classroom teaching would be replaced by online classes. It also finds that due to a lack of proper preparation and growth for doing online classes, teachers face difficulties in conducting online classes. The biggest challenge for online classes is technological and network challenges. Many researches have been conducted different studies to investigate the challenges and insights of online teaching. Nugroho et al (2021) have proved that the absence of an e-learning platform, lack of students' motivation and engagement, and time consuming for laying out online learning materials became the primary challenges of the teachers. The results depicted that developing a representative digital platform, designing online learning materials and enhancing the quality of teaching methods were some valuable perceptions from the teachers. Dumas (2016) has completed a study to find out the differences of students' performance in online classes and traditional face-to-face classes. The study has conducted with the students in an introduction to operating system course and the course was converted from a face-to-face class to online delivery. Moreover, scores of the final exam from before and after the online conversion as well as the entire test related to education were analyzed. The study results show a slight improvement in student's performance when the course went online, but not enough to establish statistical significance at the 95% confidence level.

## 3. RESEARCH METHODOLOGY

The total population of the project was the teachers of English in Sri Lankan government schools. The target population was all the teachers of English in Sri Lankan government schools who are assigned to teach English through online. Accessible population was all the teachers of English in Sri Lankan government schools who are assigned to teach English through online in Galenbidunuwewa education

zone. Sample is the selected participants of the population and they were used to collect data for the study. The sample of this study consists of 30 English teachers from different schools in the research area. Simple random sampling techniques were used in the study to select the sample. Survey method was used to collect data. The questionnaire was divided into three main sections. Demographical information (age, gender, educational zone) and previous experience and they were asked to include in the first section of the questionnaire. In the second section, twenty close ended questions were designed using five-point Likert scale to get the teachers' perceptions. The third part of the questionnaire was used to collect teachers' suggestions to uplift the effectiveness of teaching English through online. After constructing a questionnaire, to know the feasibility of the questionnaire, a pilot study was conducted and reviewed the questionnaire. Questionnaires were distributed to participants by using Google form, and participants were informed that all opinions provided by them were kept confident

Both qualitative and quantitative methods were used to analyze the collected data. The quantitative data were analyzed statistically using charts, graphs and data tables. The qualitative data were analyzed using a content analysis.

## 5. DATA ANALYSIS

### 5.1. Demographic Profile of the Respondents

These questions informed the background of the respondents, gender, age and online teaching experience were included as demographic factors to the questionnaires.

Gender of the participants	Male	50%	Online platforms used for online classes	Zoom	70%
	Female	50%		Whatsapp	20%
Age of the respondents	From 20 to 35	33.30%		Google Classroom	Insufficient
	From 35 to 45	33.30%		Google Meet	Insufficient
	Above 45	33.30%		Microsoft Teams	Insufficient
Online teaching experience	Yes	0%		Messenger	Insufficient
	No	100%			

Figure 1: Demographic factors of the sample population

Through figure 1, male and female teachers are equal in percentage; 50% each. Using this categorization, it is clear that the teachers have been classified in accordance with their age. It is from 20 to 35 years, from 35 to 45 years and teachers above 45 years. What is important is that the percentage of these three categories is 33.3% each. Next, we find the lack of knowledge on e-learning of the sample population. Every teacher has uncovered the inadequacy of their ICT knowledge. Among the media they use to launch online teaching, 70% % of teachers utilize Zoom while 20% % of teachers are using WhatsApp. Apart from these methods, other media did not seem to be very popular among teachers.

### 5.2. Perception of Teachers towards Teaching English through Online

The questionnaire of the research was prepared to achieve the first objective of the research and it consists of twenty close ended questions and all the questions in the questionnaire were divided into four main factors. They are students' performance and perception, teachers' performance and attitudes, challenges and insight of online teaching, online learning vs face to face learning.

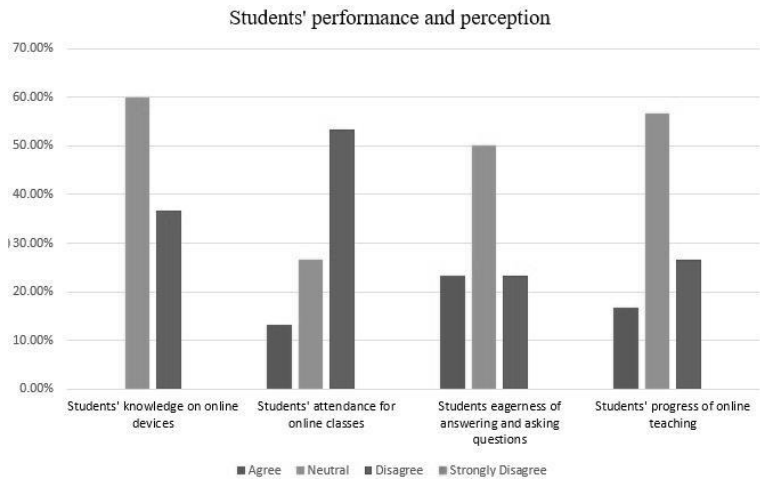

Figure 2: Students’ performance and perceptions

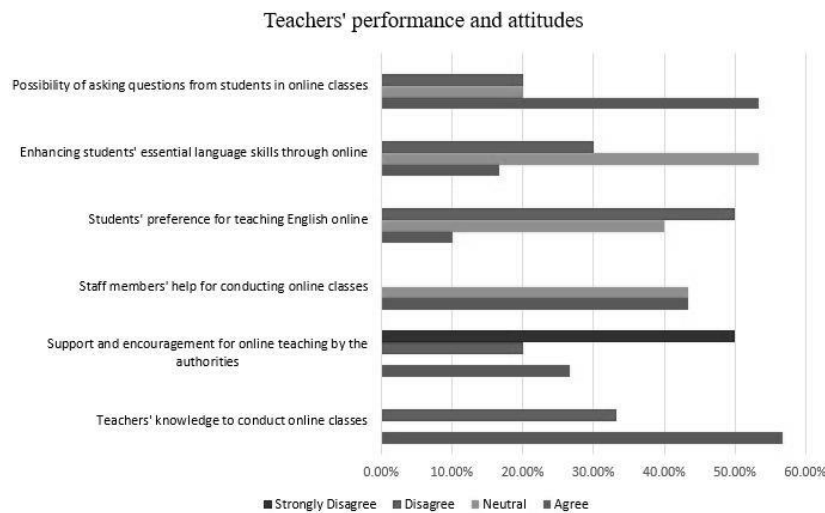

Figure 3: Teachers’ performance and attitudes

Four statements were taken under the above theme and the results are indicated in the figure 2. According to the figure, teachers have a neutral perception (60%) towards the students’ knowledge on online devices. Approximately 40% of teachers have shown their unhappiness by selecting disagree towards the statement. The above figure further reveals that more than 50% of teachers are unhappy about the students’ attendance for online classes. Approximately 30% of teachers have shown neutral perceptions towards the students’ attendance for online classes. Moreover, 50% of teachers have neutral perceptions towards students’ eagerness of answering and asking questions in an online class. Approximately 60% of teachers have neutral perceptions towards students’ progress of online teaching. By studying the above bar graphs, it is clear that teachers’ perception towards the theme of “students’ performance and perception” is neutral.

The figure 3 indicates the results of the theme “Teacher’ performance and attitudes”. According to the results of the figure, more than 50% of teachers’ positive perceptions towards the possibility of asking questions from students in online classes. In addition, more than 50% of teachers have shown neutral perceptions towards enhancing students’ essential language skills through online. It further states that 50% of teachers have negative perceptions on students’ preference for teaching English online. The results also reveal that an equal percentage of teachers (more than 40%) have positive and neutral perceptions towards the support of the staff members for doing online classes. Moreover, 50% of teachers have shown negative perceptions towards the support and encouragement given by the



authorities for online education. According to the results, approximately, 60% of teachers have enough knowledge to conduct online classes while more than 30% of teachers don't have enough knowledge on online teaching.

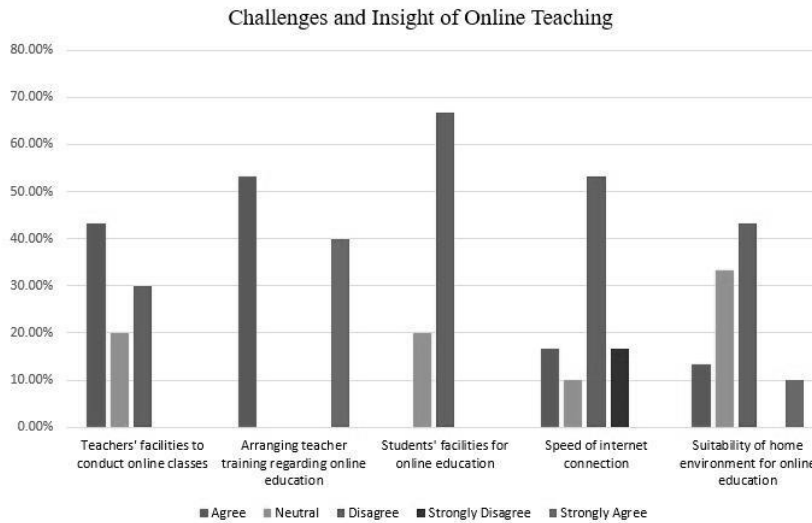

Figure 4: Challenges and insight of online teaching

Five statements of the questionnaire were categorized under the above theme and the results are indicated in the figure 4. According to the bar graph, more than 40% of teachers have positive perceptions towards the facilities to conduct online teaching. More than 50% of teachers have positive perceptions towards arranging teacher training programme regarding online teaching. The above bar graph further tells that approximately 70% of teachers have negative perceptions the facilities available for students to attend online classes. Further, more than 50% of teachers have shown negative perceptions towards the speed of internet connection. In addition, the above figure shows the suitability of home environment to conduct online classes. The perception of teachers for it is also negative. More than 40% of teachers have shown their negative perceptions towards it.

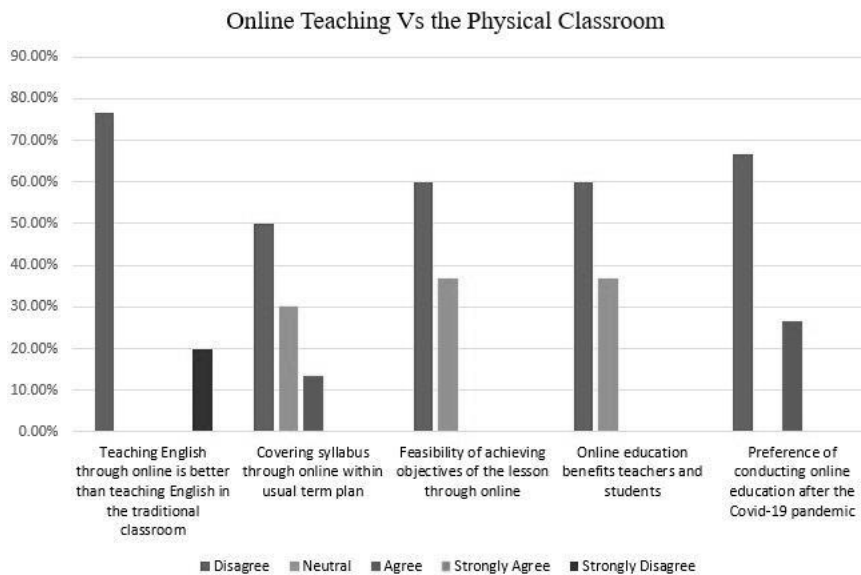

Figure 5: Online teaching Vs physical classroom

The fourth theme is “Online teaching vs the physical classroom” and the results for the statements are indicated in the figure 5. According to the bar graph, more than 70% of teachers have shown their negative perceptions towards the statement “Teaching English through online is better than teaching English in the traditional classroom. Further, 50% of teachers have indicated that covering syllabus through online within usual term plan is difficult. 60% of teachers have clearly indicated that achieving objectives of the lesson through online is not possible. The figure further indicates that teachers’ perception towards the statement “online education benefits teacher and students” is negative. 60% of teachers have shown their disagreement. The last statement of the questionnaire was “preference of conducting online education after the Covid-19 pandemic”. According to the results, approximately 70% of teachers have shown their negative perceptions towards it.

According to the results of the above bar graphs, teachers’ perceptions for eleven statements of the questionnaire (55%) are negative. The results further reveal that teachers’ perceptions for four statements (20%) are neutral. Out of all the twenty statements, positive perceptions have been shown by the teachers only for four statements (20%). In addition, an equal percentage of teachers have shown their positive and neutral perceptions towards only one statement. The huge gap of the results shows the teachers’ perceptions towards online teaching in Galenbidunuwewa education zone are negative.

## 6. CONCLUSION AND RECOMMENDATIONS

Although the Sri Lankan government has already introduced online education during the Covid-19 situation, as a newly introduced method for the Sri Lankan school education system, a number of issues have risen with aroused of the implementation of e-learning in Sri Lanka. Connectivity issues, lack of interaction, lack of knowledge and time management are some of the most prominent problems. The following solutions were suggested by the teachers to overcome the above-mentioned problems. Implementing digital classrooms in schools, providing training for both teachers and students, revising the term and year plans, taking suitable steps to uplift the quality of the internet connection, introducing video lesson for the syllabus, and organizing awareness programmes are some of the proactive suggestions given by the teachers.

## REFERENCES

- Destianingsih, A. and Satria, A., (2020). Investigating students’ needs for effective English online learning during Covid-19 for Polbeng students. *ELT-Lectura*, 7(2), pp.147-153.
- Dogoriti, E., (2010). Perceptions and attitudes towards web-based ELT among English teachers in Greece. In *The 3rd edition of the ICT for Language Learning Conference*. Retrieved April (Vol. 27, p. 2014).
- Dumas, J., (2016). Online vs. face-to-face student performance in an introduction to operating systems course. *Journal of Computing Sciences in Colleges*, 32(2), pp.185-191.
- Nugroho, A., Ilmiani, D. and Rekha, A., (2021). EFL Teachers’ Challenges and Insights of Online Teaching amidst Global Pandemic. *Metathesis: Journal of English Language, Literature, and Teaching*, 4(3), pp.277-291.
- Priyadarshani, H.D.C. and Jesuiya, D., (2021). Teacher's Perception on Online Teaching Method during COVID-19: With Reference to School Level Teachers at Faculty of Education, the Open University of Sri Lanka. *Shanlax International Journal of Education*, 9(2), pp.132-140.

# Technology Teachers' Professional Satisfaction and Working Environment

D. K. Chathumi Nawanjana<sup>1</sup>, Y.S. Manathunge<sup>1\*</sup>, Prasanna Illankoon<sup>2</sup>

<sup>1</sup>Department of Education and Training, University of Vocational Technology, Sri Lanka

<sup>2</sup>Department of Manufacturing and Industrial Engineering, University of Peradeniya, Sri Lanka

## ABSTRACT

*This study investigates the relationships between the working environment and the professional satisfaction among technology teachers in Zonal Education of Matugama. Forty technology teachers replied to a questionnaire that covers the aspects of the working environment and the aspects of job satisfaction. The responses were analyzed using descriptive statistics and inferential statistics. The result shows an overall professional satisfaction level of "satisfied". Most of the teachers were very satisfied with the job itself. The least satisfying aspect among teachers was salary. No significant difference was found between the professional satisfaction of female teachers and male teachers. There is a positive correlation between overall professional satisfaction and the working environment. Results pave the way to important recommendations based on the fact that the perception about the working environment can in fact bring the way the teacher sees how their profession is satisfactory.*

**Keywords:** Professional Satisfaction, Teaching Environment, Technology Teaching.

## 1. INTRODUCTION

Professional satisfaction is the positive or pleasant emotional state relating from a person's appreciation of his/her own job or experience (Locke, 1976). Professional satisfaction can be measured in cognitive, affective and behavioral components. There are varieties of factors that can influence teachers' professional satisfaction. Those factors divided into two categories. Personal factors such as age, sex, family background, education level, socio economic background, interest, and experience influence on professional satisfaction. Internal factors including salary, promotions, working conditions, benefits, leadership, social relationship, opportunities, working environment influence the same. Generally accepted is that the salary and working conditions are most influential to professional satisfaction.

Working conditions means all surroundings when working in the workplace. Physical working environment and psychological aspects are included in the working environment. Working environment includes the workplace, job hours, legal rights, physical aspects, responsibility, workload and organizational climate. These concepts may impact upon feelings of wellbeing, workplace relationships, collaboration and efficiency and teachers' health. While yet, as this study attempts to bridge, more has to be understood about the connections between the professional satisfaction and the working environment. Teaching is one of the most popular professions in Sri Lanka. Technology stream was introduced in 2013. Therefore researchers mainly hope to identify whether A/L technology teachers are satisfied or not with their teaching profession. Furthermore researchers find factors affecting the A/L technology teachers' professional satisfaction and how to improve their professional satisfaction.

## 2. PREVIOUS STUDIES

The foremost popular definition given by Locke (1976), professional satisfaction is a positive appreciation or else pleasant sensitive state resulting from a person's appreciation of their own job. Professional satisfaction is a job attitude as a total emotion in one's career. Professional satisfaction may be categorized as per the requirements of the individual. Another view is that job satisfaction could be a behavior that shows the satisfaction level of a private at their workplace (Griffin, 2000). It is

---

\* Corresponding author: E mail - [ymanathunge@gmail.com](mailto:ymanathunge@gmail.com)

challenging to explain because different people have different opinions (Panday & Kavitha, 2015). Job satisfaction is a multidimensional concept. There are two main factors affecting professional satisfaction. They are personal factors and environmental factors (Pandey & Kavitha, 2015). Some personal factors such as gender (Fredy, 2009, Ahmed), (Raheem and Jamal, 2003), (Achanta & Reddy, 2014), age (Jyoti, 2006) marital status (Fredy, 2009) family background (Claudia Galindo, 2016), level of education, experience (Reyes, 1990), interest (Paswan & Young, 2002) leads to teacher's job satisfaction.

Rahman (2008) observed job satisfaction among public and private college teachers in Bangladesh. It discovered effective factors in finding the satisfaction and dissatisfaction of teachers. Wages and salaries (Kanojan.K & Sivalogathan, 2017) and income level associated with position, lifestyle and freedom (Fredy, 2009) working conditions (Kanojan.K & Sivalogathan, 2017) (Luthan's,1989) opportunities for development (Saal and Moore, 1993) leadership (Flippo, 2010), social relationships (Sargent & Hannum, 2005) affect to the professional satisfaction. Wages and salaries (Kanojan.K & Sivalogathan, 2017) and income level associated with position, lifestyle and freedom (Fredy, 2009) working conditions (Kanojan.K & Sivalogathan, 2017) (Luthan's,1989) opportunities for development (Saal and Moore, 1993) leadership (Flippo, 2010), social relationships (Sargent & Hannum, 2005) affect to the professional satisfaction. According to Leblebici (2012), a supportive work environment helps workers to perform normal duties more effectively, making best use of their knowledge, skills and competencies and the available resources in order to provide high quality service.

Teachers face different challenges throughout the work. Among the challenges, the working environment is one of the major factors. The physical work environment can impact on the level and nature of social interactions between co-workers. Therefore, a reasonable assumption is that the working environment in school affects teacher behavior in several aspects. If the school has the best facilities when the teachers perform level upgrades, students' learning productivity could improve, thus it can be assumed that the teachers' satisfaction improves as the working environment improves. However, only a limited number of studies have been conducted on the connections between the working environment and the teachers' professional satisfaction.

### **3. RESEARCH OBJECTIVES**

This research study addresses the following research objectives:

1. To identify the level of professional satisfaction of the technology teachers.
2. To identify the differences between professional satisfactions based on gender and civil status.
3. To identify the effect of the technology teachers' working environment on the professional satisfaction.

### **4. METHODOLOGY**

The researchers used a simple random sampling method to conduct this research. The area selected for the study is the Zonal Education of Mathugama. The target population for this study includes all technology school teachers in Zonal Education of Mathugama that comprises of five technology schools namely WP/MT/ C.W.W.Kannangara M.M.V., WP/MT/ Ananda Sastralaya National School , WP/MT/ Mihindu M.M.V., WP/MT/ Kamburawala M.V. and WP/MT/ Colvin R De Silva M.V. Those schools have 40 teachers teaching technology subjects. The population of this study consisted of genders. The questionnaire is divided into three sections. First section is background information which includes gender, age, qualifications level, length of service and location of school. Second and third sections contain Teacher Professional Satisfaction Questionnaire and Working Environment related Questionnaire which include 20 Likert scale items. A likert type scale was used and the respondents select one of five options: Strongly disagree, Disagree, Neutral, Agree, Strongly agree.

In this study various statistical techniques are used for analyzing data. Descriptive method used to analyze data such as mean and standard deviation. Inferential statistics contains correlation analysis.

Mainly Microsoft XL Software used to analyze data. Bar charts and graphs were also applied for indicating results of analyzed data.

## 5. RESULTS AND DISCUSSION

The results are presented addressing the objectives of the research. Descriptive analysis and inferential statistics have been used in this analysis. To conduct the statistical analysis the likert scale responses were transformed to numbers as; Strongly disagree = 1, Disagree = 2 Neither agree or disagree = 3, Agree = 4, Strongly Agree = 5

### 5.1. Demographic Information

Summary of demographic information of 40 technology teachers who responded, are as follows;

Gender: 32% male, 68% female

Civil Status: 75% unmarried, 25% married

Age: 20-30 years 10%, 31-40 years 70%, 41-50 years 10%, 51 years or above 10%

Level of Education: Bachelor Degree 68%, Diploma 17%, Masters' Degree 15%

Working experience: 1-5 years 37%, 6-10 years 38%, 11-15 years 10%, 20 years or above 15%

### 5.2. Teachers' Level of Professional Satisfaction

The first objective of the study was to determine the level of professional satisfaction. Figure 1 shows the average level of satisfaction shown under the 10 questions. Figure 3 shows the Histogram of responses for the 10 questions those related to satisfaction.



Figure 26: Average level of professional satisfaction shown under the 10 questions

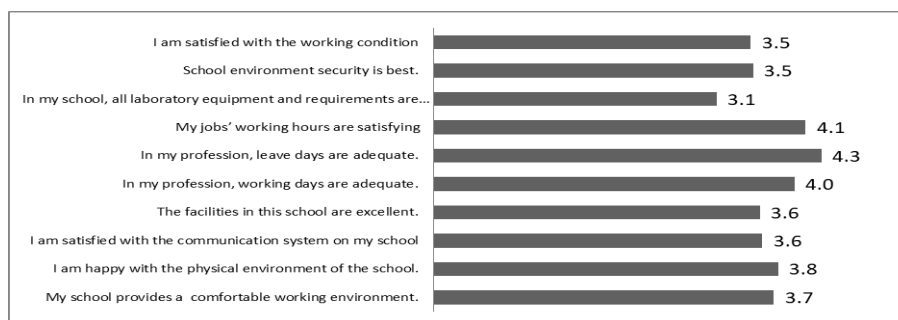

Figure 27: Average level of the perception shown under the 10 questions about the environment

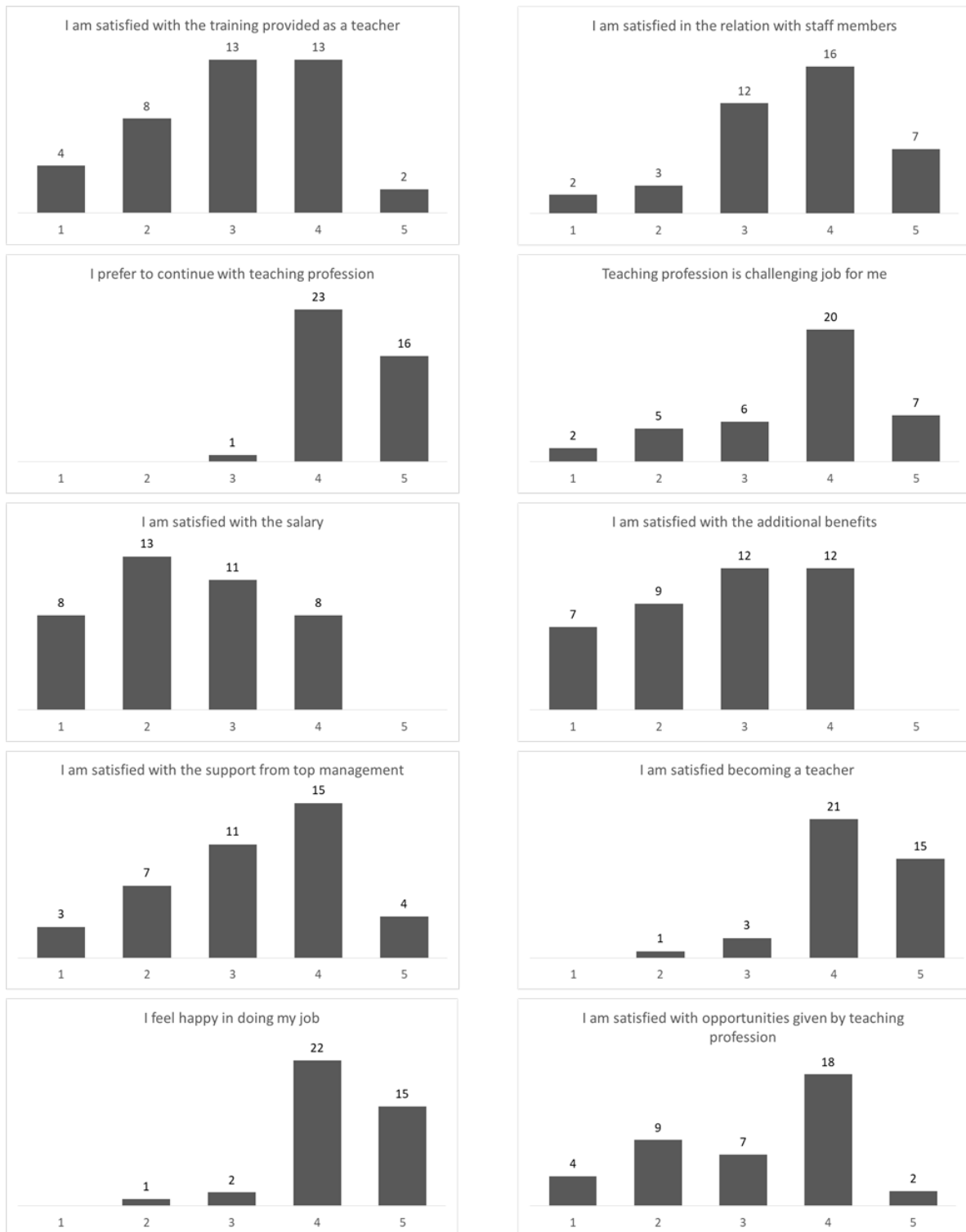

Figure 28: Histogram of responses for 10 questions related to satisfaction

### 5.3 Overall Perception of the Teachers about the Working Environment

Figure 2 shows the average level of the perception responded under the 10 questions those related to the working environment.

#### 5.4. Professional Satisfaction Vs. Gender

The overall satisfaction was calculated by averaging the responses for the 10 questions related to the satisfaction. Considering the overall satisfaction, most female teachers were satisfied with their job. It was percentage as 81%. Most of male teachers were also satisfied with their job (92%). As a percentage, male teachers are more satisfied with their profession than female teachers. However, the statistical difference was tested using the Mann-Whitney U Test. The Mann-Whitney U test is used to compare differences between two independent groups when the dependent variable is either ordinal or continuous, but not normally distributed. The statistical analysis does not show a significant difference.  $H_{10}$ : There is a significant difference in overall satisfaction based on the gender. The Z-Score is -0.82298. The p-value is .41222. The result is not significant at  $p < .05$ .

#### 5.5. Professional Satisfaction Vs. Civil Status

Considering overall satisfaction, the married teachers are more satisfied with their profession (overall satisfaction = 3.48) than the unmarried teachers (overall satisfaction = 3.43). However, the statistical difference was tested using the Mann-Whitney U Test. The statistical analysis does not show a significant difference.  $H_{20}$ : There is a significant difference in overall satisfaction based on the civil status. The Z-Score is 0.21864. The p-value is .82588. The result is not significant at  $p < .05$ .

#### 5.6 Professional Satisfaction Vs. Demographics and the Perception of the Working Environment

Person correlation was calculated between the responses to the 10 questions related to the satisfaction and the overall satisfaction with related to age, years if experience, level of education, the extent which working in the own field, and the overall perception about the working environment. The overall perception about the environment was calculated by averaging the responses for the 10 questions related to the working environment.

Table 1: Correlation between the satisfaction and demographics

	Age (Level)	Experien ce (Level)	Education (Level)	Own Field	Overall Perception about the Environment
<b>I am satisfied with the training provided as a teacher</b>	0.246	0.090	0.001	0.204	0.276
<b>I am satisfied in the relation with staff members</b>	0.111	0.175	0.025	<b>0.485</b>	<b>0.629</b>
<b>I am satisfied becoming a teacher</b>	<b>0.335</b>	<b>0.337</b>	0.204	<b>0.411</b>	<b>0.461</b>
<b>I prefer to continue with teaching profession</b>	<b>0.376</b>	0.254	0.278	0.269	<b>0.574</b>
<b>Teaching profession is challenging job for me</b>	<b>0.345</b>	0.190	0.232	0.117	0.259
<b>I feel happy in doing my job</b>	0.239	0.206	-0.113	0.294	0.247
<b>I am satisfied with the salary</b>	0.039	0.083	-0.065	0.050	0.027
<b>I am satisfied with the additional benefits</b>	0.037	0.029	0.030	0.137	0.219
<b>I am satisfied with opportunities given by teaching profession</b>	0.149	0.169	0.044	<b>0.383</b>	<b>0.541</b>
<b>I am satisfied with the support from top management</b>	0.153	0.238	0.010	<b>0.439</b>	<b>0.547</b>

<b>Overall Satisfaction</b>	0.277	0.245	0.081	<b>0.406</b>	<b>0.549</b>
-----------------------------	-------	-------	-------	--------------	--------------

Only a weak positive correlation could be identified between age and the extent to which working in the own filed with related to some of the professional satisfaction questions. Moderate correlations were noted between some of the professional satisfaction areas and the overall perception about the working environment as shown in Figure 4.

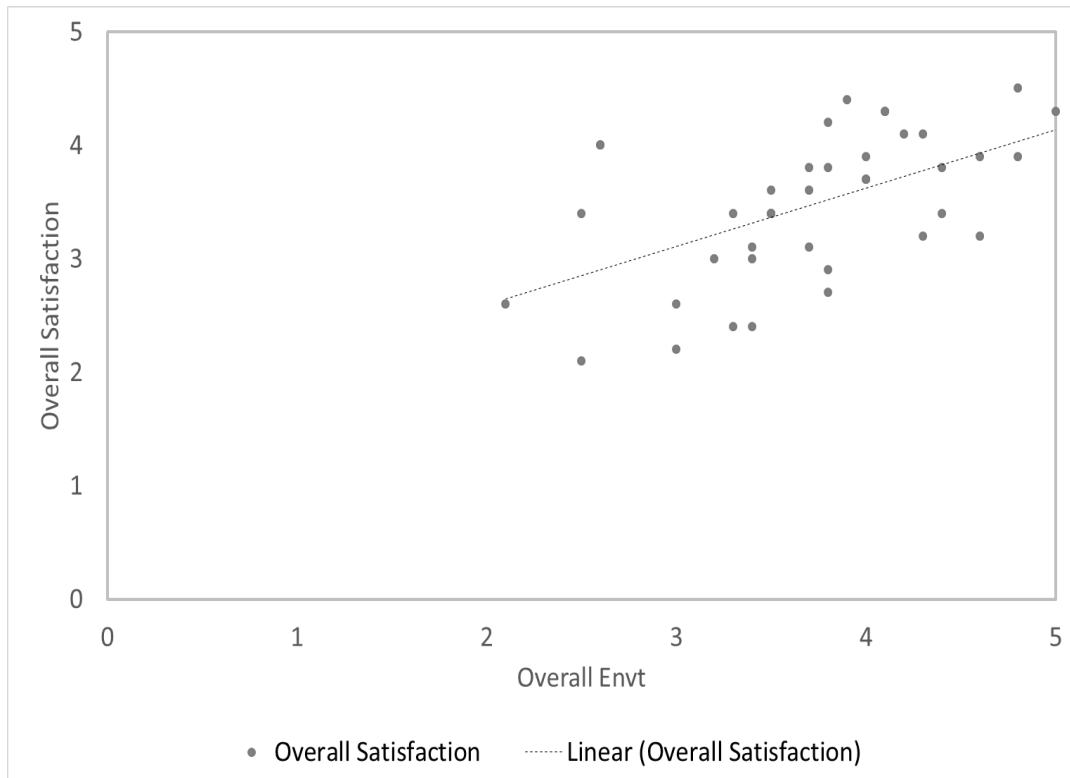

Figure 29: Correlation between the overall perception about the working environment and the overall level of professional satisfaction

## 6. CONCLUSIONS

The first research question identified the level of professional satisfaction of the G.C.E.A/L technology teachers. The study findings revealed that the overall professional satisfaction level is “satisfied”. “I am satisfied to become a teacher”, “I prefer to continue with the teaching profession”, and “I feel happy in doing my job” had been rated high. Most of the teachers were unsatisfied with their salary. Additional benefits, support top management, opportunities and training were moderate satisfaction levels.

The second research question identified the difference between male and female teachers’ professional satisfaction. Although the average responses suggest that the female teachers are more satisfied with the teaching profession, the statistical analysis does not show a significance difference. There is no statistical significance is the level of professional satisfaction against the civil status.

Third research question identified the effect of the working environment on technology teachers’ professional satisfaction. A moderate positive correlation is evident between the overall level of the satisfaction and the overall perception about the working environment. Interestingly, positive correlations were found in the relation with staff members, preference to continue with teaching profession, opportunities given by teaching profession, and support from top management against the overall perception about the working environment.



This research used both descriptive and inferential statistics to unrevealing some of the important relationships. Interestingly the level of education has not shown any significant relationship with the level of professional satisfaction, however, the perception about the working environment seems to be playing a main role in bringing professional satisfaction. It suggests that the school authorities should focus more on the working environment in bringing more professional satisfaction to the teachers. Very week negative correlations of feeling happy and satisfaction with the salary against the education level worth further investigations.

## REFERENCES

- Locke E. (1976). *The Nature and Causes of Job Satisfaction*. Retrieved October 20, 2020, from ResearchGate: [https://www.researchgate.net/publication/238742406\\_The\\_Nature\\_and\\_Causes\\_of\\_Job\\_Satisfaction](https://www.researchgate.net/publication/238742406_The_Nature_and_Causes_of_Job_Satisfaction)
- Achanta, S. &. (2014). Job Satisfaction among Primary School Teachers in Krishna District. *INDIAN JOURNAL OF RESEARCH*.
- Ahmed, M. M. (2018). *Teachers' Job Satisfaction: A Study in Secondary*. Definition of job satisfaction, Robbins & judge 2008, Spector1997.
- Education, 4. I. (2017). Saal and Moore (1993). *TEACHING PERFORMANCE AND JOB SATISFACTION AMONG TEACHERS AT REGION XI*.
- Flippo, E. B. (2010). *Personnel Management*. McGraw Hill Series in Management.
- Fredy. (2019). *Job satisfaction of school teachers in Tanzania*. Retrieved December 18, 2020, from Dissertation for the Masters' Degree Thesis in Education, M.Ed. [Online] Institute of Educational Leadership: <http://www.netlibrary.com/reader>
- Galindo, C. (2016). *School–family relationships, school satisfaction and the academic achievement of young people*.
- Kanojan K., & Sivalogathan V. (2017). *Job Satisfaction and Intent to Leave Among Graduate Teachers in Government Schools in Sri Lanka*. *Journal of Business Studies*, 104.
- Leblebici. (2012). *Impact of Workplace Quality on Employee's Productivity*. *Journal of business, economic and finance*.
- Luthans, F. (1989). *Organizational Behavior*. 5th Edition. New York: McGraw-Hill Inc.
- Kavitha M., Panday N.S. (2018). *Relationship between Big Five personality and Job Satisfaction of Private high School*. *International Journal of Research in Economics and Social Science*.
- Moorthy, D. D. (2013). Ahmed, Raheem and Jamal (2003). *A Study on the Job Satisfaction of Female School Teachers in Theni District*.
- Paswan, K., & Young, J. A. (2002). *Student evaluation of instructor: A nomological investigation using structural equation modeling*. *Journal of Marketing Education*.
- Sharma R.D. & J. Jeevan. (2006). *Job Satisfaction among School Teachers*. *IIMB Management Review*.
- Rahman, M. I. (2008). *Job satisfaction among public and private college teachers of Dhaka City*. Retrieved from <https://doi.org/10.2139/ssrn.1737285>
- Sargent, T. &. (2005). *Keeping teachers happy: Job satisfaction among primary school teachers in rural Northwest China*. *Comparative Education Review*.
- WANGAI, M. M. (2012). Reyes' (1990). *FACTORS AFFECTING JOB SATISFACTION AMONG SECONDARY SCHOOL TEACHERS OF MWATATE DISTRICT, KENYA*.

## **TECHNO - SOCIAL SUSTAINABILITY**

# A Follow up Study on the Career Progression of the First Batch of Graduates of University of Vocational Technology

D.D.D.Suraweera<sup>\*1</sup>, L.W.S.Kularatne<sup>2</sup>

<sup>1</sup>Department of Electrical and Electronics, University of Vocational Technology, Sri Lanka

<sup>2</sup>Department of Language Studies, University of Vocational Technology, Sri Lanka

## ABSTRACT

*University of Vocational Technology was established with the aim of providing opportunities of achieving higher education qualifications to those in Sri Lanka who have acquired technical and vocational education and training qualifications at Diploma level. The University became operational from 2009. The first batch of students were the teachers serving in the TVET agencies. They were offered Bachelor of Education in Technology degree and graduated in 2011. This tracer study was conducted to ascertain their career progression one decade after their graduation. The graduates were contacted over the phone and an online questionnaire was administered to collect data. 50 % of graduates had secured promotions in their career, 30% had completed post graduate studies at state universities while 30% of them had reached the peak of their career as a result of obtaining the degree qualification. However, 70 % respondents had opinion that they would have been benefitted more, if they had followed Bachelor of Technology degree. All graduates were of the view that they received very highly satisfactory support from the staff and conducive environment from the University without which they would not have been able to complete the degree successfully being mid-career employees with multiple commitments.*

**Keywords:** Bachelor of Education in Technology, Tracer Study, University of Vocational Technology.

## 1. INTRODUCTION

A university education is considered prestigious and therefore the aspiration for acquiring academic qualification is supported by social and cultural values of most countries (Atchaoarena, 2009). Sri Lanka's higher education system is highly competitive. State universities have very stringent entry criteria based on G.C. E. (Advanced Level). Therefore, no one is able to join the state universities with alternate entry qualifications to follow the first degree.

The personnel serving in the Technical and Vocational Education and Training (TVET) sector did not have opportunities to pursue higher education as the Tertiary and Vocational Education Commission (TVEC) or other institutes did not have powers to offer such qualifications to them. National Institute of Technical Education of Sri Lanka (NITESL) realized the need and commenced to offer Advanced Diploma in Technical Education (ADTE) to the teachers who were employed in the sector. They were in the middle of their career at the time of the enrolment to the programme in the year 2008. They were released from their places of work to follow the course fulltime and funded by ADB assisted Technical Education Development Project (TEDP) of the line Ministry. The Institute hostel provided accommodation for them thus enhancing their learning experience. With the establishment of National Vocational Qualifications Framework of Sri Lanka (NVQFSL), a need arose to create an institution with powers to award higher education qualifications at degree level which is the Level 7 of the Framework. NITESL was selected as the institution to be upgraded to the university status.

Hence, with the establishment of University of Vocational Technology (UoVT) under the Parliament Act No. 31 of 2008, NITESL was subsumed to the newly established university.

---

\* Corresponding Author: E-mail - [dimuthusiri@gmail.com](mailto:dimuthusiri@gmail.com)

As a result of the new development, ADT course was converted to Bachelor of Education Technology.

Bachelor of education in technology (B.Ed. Tech.) degree programme and offered by the then Faculty of Training Technology of the newly established university. This degree programme of three-year duration which was unique in nature with the objectives of enhancing the graduates teaching skills as well as their managerial skills. Therefore, the course content consisted of 50% of credits allocated for enhancing technology specialization areas based on their entry qualifications and the rest 50 % for education modules. Students were provided opportunities to enhance their competencies in the areas of curriculum development, education management, professional development, assessment and evaluation and research methodology.

Thirty-two students were enrolled in the first batch out of which five left the course due to their other commitments. 26 successfully completed their studies and passed out in the year 2011. Four of them have already retired from the service and the rest are still actively involved in various capacities in the TVET sector institutes of Sri Lanka.

A Tracer Study helps university to evaluate the results of the performance of institution-specific education and training, and provides information for analysis of employability and career advancement of graduates (Boaduo, Mensah & Babizeng 2009).

It may reveal important facts of positions of graduates, work experience, the nature of the job, income level and curriculum (Schomburg, cited in Millington, *nd*).

One way for universities to understand success of their graduates is that they must undertake postgraduate studies. Burke (2005) argues that tracer studies assess the perception of graduates of their learning experience over several years of study. It is expected that such study will improve the understanding of the university on student preparation and success of Alumni.

Although tracer studies have been used since the latter part of twentieth century (Melchiori 1988, Pettit 1991 and Pike 1994), unfortunately, research is lacking for various reasons, including concerns that these studies may adversely affect the standard of teaching, learning and assessment process.

In Tracer Studies, university collects information on the professional development, subsequent post graduate studies under taken by graduates and the applicability of the competencies acquired during studies to the world of work (Schomburg 2003).

There has been no Tracer Study conducted to evaluate the career progression of the first batch of graduates of B.Ed .Tech. degree programme of UoVT. Therefore, this study was conducted to ascertain the destinations of the graduates 10years after their graduation with the following objectives.

## **2. OBJECTIVES**

1. To determine the Impact of Bachelor of Education Technology degree on the personal and professional development of the graduates.
2. To identify the perception of the graduates on the usefulness of the Bachelor of Education in Technology degree.
3. To identify the level of acceptance of the Bachelor of Education in Technology degree offered by the University of Vocational Technology by the employers.

### 3. METHODOLOGY

The study was conducted as a descriptive survey using which involved quantitative data collected from all graduates of the first batch of the B.Ed. Tech. degree who graduated in the year 2011. It was decided to identify the impact of the degree on personal and professional development of the graduates by collecting information about their career promotion and further studies. The graduates are the best source to identify the usefulness of the degree to the holders. The recognition given by the employers to the degree is reflected by the promotions and other career prospects given to the graduates. Therefore, data was collected from the graduates through a questionnaire aiming to find information related to the objectives of the study.

A structured questionnaire consisting of 12 closed type questions was used to collect data. The questionnaire was pilot tested by administering it to three graduates and modifications to the questionnaire were done based on their feedback before wider circulation. It was administered using a Google form to 25 graduates. One graduate was not able to be contacted. The graduates were contacted over the phone personally, explained the purpose of the study and to motivate them to respond. A very highly positive response was observed from the 22 respondents even though 16 % had already retired from the active service.

### 4. DATA ANALYSIS

The composition of the sample with respect to their subject areas of specialization at the enrollment is given in the Figure 1 which consisted of 17 Males and 09 Females. Two respondents each were from Vocational Training Authority of Sri Lanka and National Apprenticeship and Industrial Training Authority. Whereas the balance 18 were from the Department of Technical Education and Training.

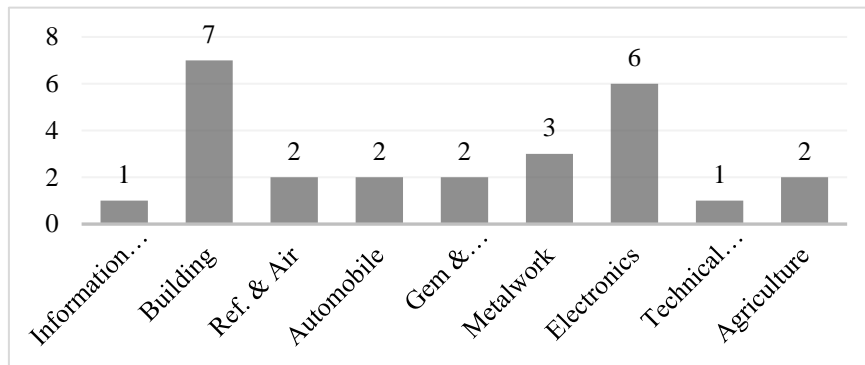

Figure 1: Composition of the Sample

Respondents were asked to provide details about the promotions they received based on the B.Ed. Tech. degree qualifications. Responses received are illustrated in the Figure 2.

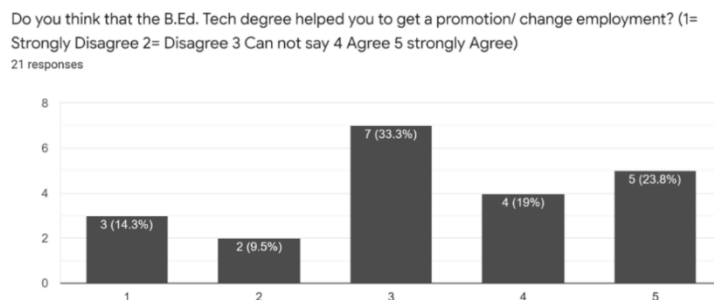

Figure 2: Promotions Received by Graduates

The B.Ed. Tech. degree qualification has opened an avenue for the graduates to obtain further higher educational qualifications at post graduate level. According to Figure 3, 59.9 % of graduates had competed post graduate studies in other state universities.

Respondents were asked to express their perception of the usefulness of the B.Ed. Tech. Degree. Their responses are illustrated in the Figure 4. Accordingly, 36.3% were happy about the degree they followed. However, 22.7% expressed that their chances would have been higher if they have followed B.Tech. degree.

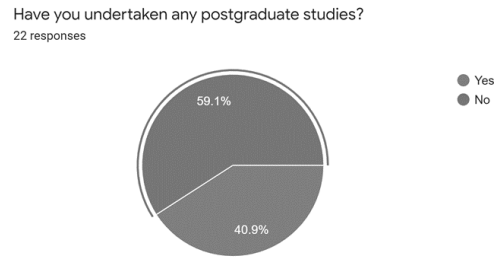

Figure 3: Higher educational qualifications obtained by graduates

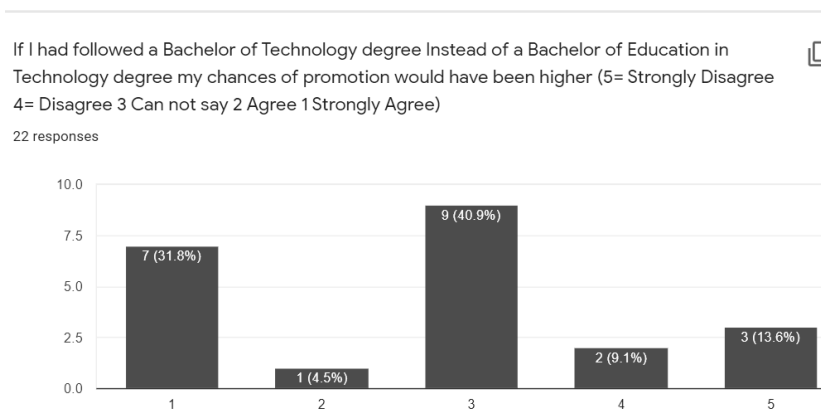

Figure 4: Graduates’ Perception of Usefulness of the Degree

In response to the question on the employers’ recognition of the degree, 40.9% responded that the degree was recognized. Whereas, 27.2% had indicated a negative response.

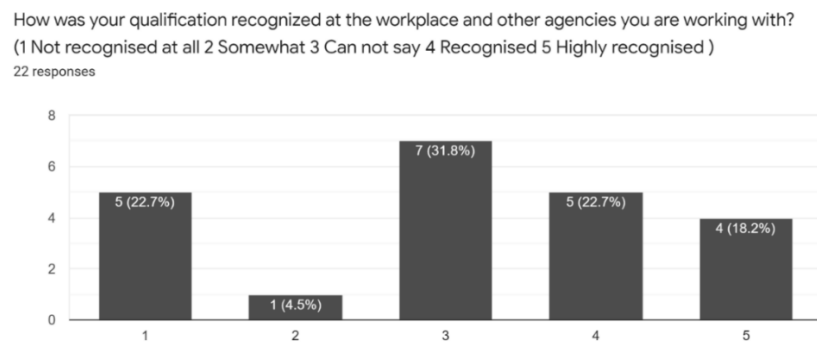

Figure 5: Employers’ Recognition of the Degree

## 5. FINDINGS

According to 27.2% of graduates, upon returning to the respective work places they have been told by the administrators that the degree is not valid and cannot be recognized as it is not a University Grants Commission (UGC) recognized degree. However, those agencies had given paid duty leave and the line Ministry had given scholarships for them to pursue study through Technical Education Development

Project of the line ministry which was financed by Asian Development Bank. Further, when they have applied for promotions related to technical positions, they have been told that the degree cannot be considered as these positions demand technology degrees and not education degrees. On the other hand, when they have applied for management positions, they have been told that the degree cannot be considered as it is not a pure education degree. This indicates lack of awareness and understanding among the administrative and human resource officers of the TVET institutions about the degrees offered and the legal status given to the University by the Parliament Act No 31 of 2008. According to the respondents some promotional positions had demanded Masters qualifications. As the University of Vocational Technology had not commenced Master level programmes, 41 % of respondents has followed Master's degree programmes at six state universities including University of Colombo and University of Peradeniya to qualify for the promotional benefits. Other state universities have recognized the B.Ed. Tech. degree as entry requirement in the fields of Electronics, Agriculture and Business Management. This shows that the degree is being recognized by the state universities although some of the relevant TVET institutes had hesitated to give due recognition by giving various reasons after sponsoring them to pursue studies at the University. However, 48% of graduates had received promotions within four to eight years after graduation. 12 out of 22 contacted had secured promotions with administrative positions. However, 36.3% of the respondents are of the opinion that their chances for promotion would have been higher, if they had followed Bachelor of Technology degree instead of B.Ed.Tech. degree.

## 6. CONCLUSIONS

All respondents appreciated the conducive environment provided by the University for their studies, guidance and the supportive role played by the Faculty and other supportive services. It had been of immense value for them to continue and to complete their studies at the University, being mid-career professional irrespective of family and other commitments. In response to the question on the recognition of the degree 50% of the respondents expressed that they received mixed views from the employers. It was noted that 70% of the respondents were of the opinion that their promotional chances would have been higher, if they had followed a B.Tech. degree. An average response was received about the usefulness of the degree on their career progression. Despite all these pros and cons, 30% of them have reached the peak of their careers a decade after their graduation. This shows the usefulness of offering the Bachelor of Education in Technology degree targeting the teachers of TVET sector for assisting their career progression. The existence and mandate of the University of Vocational Technology has been accepted by other state universities, whereas the other TVET agencies functioning under the line ministry have shown doubts on the acceptance of the degrees offered by the University.

## REFERENCES

- Atchaoarena, (2009), 'Linking the development of tertiary education and the labor market in small states: between location and international.' *Tertiary Education in Small States: Planning in the context of globalization*. IIEP/SEM 293/4. UNESCO.
- Boaduo, NA-P, Mensah, J & Babitseng, SM. 2009, 'Tracer study as a paradigm for the enhancement of quality course programme development in higher education institutions in South Africa.' Paper presented at the Educational Colloquium, University of North-West, Potchefstroom, South Africa, 20–21 August 2009.
- Burke, J. C. (2005), 'The three corners of the accountability triangle: serving all, submitting to none in:' JC Burke (Ed.), *Achieving Accountability in Higher Education*. (pp. 296-324). San Francisco: Jossey-Bass.
- Dumford, A. D., & Miller, A. L. (2015), 'Assessing alumni success: income is not the only outcome!' *Assessment and Evaluation in Higher Education*, 42 (2), 195-207.
- Harvey, L. (2000), 'New realities: the relationship between higher education and employment.' *Tertiary Education and Management*. Retrieved May 15, 2018, from <https://qualityresearchinternational.com/essetools/relatedpubs/New%20Realities.pdf>.
- Melchiori, G.S. (1988), 'Alumni research: methods and applications.' *New Directions for Institutional Research Series*. 60: 5-12. San Francisco: Jossey-Bass.

- Millington, C. [nd]., 'The use of tracer studies for enhancing relevance and marketability in online and distance education.' [http://wikieducator.org/images/e/e1/PID\\_424.pdf](http://wikieducator.org/images/e/e1/PID_424.pdf) (Accessed 1 June 2010).
- Pettit, J. (1991), 'Listening to your alumni: one way to assess academic outcomes.' *AIR Professional File*, 41, 1-1
- Pike, R. (1994), 'The relationship between alumni satisfaction and work experiences.' *Research in Higher Education*, 35 (1), 105-123.
- Zemsky, R. M. (2005), 'The dog that doesn't bark: why markets neither limit prices nor promote educational quality' *Achieving Accountability in Higher Education*. (pp. 275-295). San Francisco: Jossey- Bass.



# Contribution of Technical and Vocational Education in Poverty Reduction: A Case from University of Vocational Technology

N.L.B. Oshadie<sup>\*1</sup>, Dilini Ranasuriya<sup>2</sup>, Jayalal Wettasinghe<sup>3</sup>

<sup>1</sup>Department of Management Studies, University of Vocational Technology, Sri Lanka

<sup>2</sup>Department of Language Studies, University of Vocational Technology, Sri Lanka

<sup>3</sup>Department of Mechanical and Manufacturing Technology, University of Vocational Technology, Sri Lanka

## ABSTRACT

*Poverty is obviously a massive hindrance to the development of any country, and therefore it is indispensable to pay special attention to reducing poverty. Various poverty reduction measures can be experimented and effectively employed. This study examined the technical and vocational education's contribution to youth poverty reduction in Sri Lanka after completing university education, by taking the case of graduates of University of Vocational Technology (UNIVOTEC) of Sri Lanka, which is the only Sri Lankan university that offers vocational technology degree programmes. The main objective of this study is to investigate how the technological degrees offered by UNIVOTEC contribute towards poverty reduction among youth after graduation. A qualitative research methodology was employed for the study with thirty two students from low-income families and followed a degree in five different areas of studies. Semi-structured interviews were conducted and analyzed using the thematic method. This study's findings demonstrated that technical and vocational education can help people get out of poverty by equipping graduates with required knowledge and skills and by making our youth highly competent so that they can be self-employed or employable in the industry straight away after completing university education. The study also emphasized a high need to expand the range of vocations to which the degrees are awarded, especially in agriculture, food technology, video production, beauty culture, etc.*

**Keywords:** Empowering youths, Poverty reduction, Technical and vocational education.

## 1. INTRODUCTION

Poverty is considered a hindrance to the development of any country. According to UN publications, over one billion people live in poverty across the world today, primarily in developing nations, notably rural regions of low-income countries such as Asia and the Pacific, Sub-Saharan Africa, Latin America, and the least developed countries (Borode, 2011). Therefore, it is essential to pay significant attention to poverty reduction measures or income generation. Poverty and education are negatively interrelated. Because education offers information and skills that promote better incomes, the lower the population's level of education, the fewer the poor will be. (Awan *et al.*, 2011). Policymakers, donors, and the private sector have ignored the vital field of Technical, Vocational Education and Training (TVET) for many years, despite being a critical component in reducing rural poverty (Hartl, 2009). This is especially pertinent to the lives of young people once they have completed their university studies. This study addresses the problem that, how vocational education can contribute to poverty reduction, especially after university education in vocational technology. For that purpose, the University of Vocational Technology was taken into consideration as it is the only state university in Sri Lanka that provides the degree programmes in Vocational Technology.

The study's major goal was to determine the impact of technical and vocational education in Sri Lanka's poverty reduction efforts, especially the degree programmes offered by the University of Vocational Technology. Apart from the main objective researcher also aim to achieve the following objectives.

---

\* Corresponding Author: E-mail - [nlboshadie@yahoo.com](mailto:nlboshadie@yahoo.com)

- i. To determine the influence of technical and vocational education on the ability of Sri Lankan adolescents to earn a living.
- ii. To investigate how technical and vocational education might help Sri Lankan youngsters achieve their poverty reduction goals.
- iii. To investigate the ways that technical and vocational education contribute in order to reduce poverty among youths in Sri Lanka.

Kurtishi-Kastrati (2013) stated that with the implementation of improved curricula and adequate resources, technical and vocational education and training (TVET) not only produces competitive workforce in developing countries with high chances of finding decently paid employment, but it also benefits multinational enterprises and consumer markets in developed countries that have been consuming the goods and services produced by developing countries. UNESCO (2013) has stated that Due to a lack of sufficient skills, potential workers have difficulty finding work in the labor market. Khwaja (2009) has mentioned that Current technology is extremely rapid; it is altering the face of the world over time, and new technologies are increasingly substituting human labor with mechanical technologies. Only skilled or semi-skilled personnel can meet the needs of an industry in this new era of labor. To develop a skilled workforce, Technical and Vocational Education and Training (TEVT) is directly related to what a person need and must become. Ziderman and Adams (1993) proposed that In comparison to formal education, vocational training has a stronger connection. There are some perceived vocational training values that are linked to wages and meet the demands of the workplace.

## 2. METHODOLOGY

In-depth semi-structured interviews were conducted to identify the importance of technical and vocational education in Sri Lanka's poverty reduction. The sample was taken from passed out students of the University of Vocational Technology Sri Lanka as it is the only Sri Lankan state university to offer degrees in Vocational Technology. For the interviews, thirty two (32) interviewees have been selected from students who were graduated since 2013. As per the UNDP (2000), economic poverty is defined as a household having less than \$1.25 per day in financial resources to cover its basic requirements, which can be measured in absolute/ relative terms. Therefore, graduates for the interviews were selected from the category of having a monthly income of Rs 25,000 at the entrance to the university. This is the level of income considered when awarding Mahapola scholarship in Sri Lanka. Further, those students entered the university from National Vocational Qualification (NVQ) ladder. In order to achieve the research objectives of the study, the interviews are conducted using the following steps:

- Step 01. Develop an interview tool
- Step 02. Preliminary discussions
- Step 03. Semi structured interview
- Step 04. Choose key informant

The questions for the guidelines are developed based on the research questions of this study.

According to the objectives of the study, the following interview guidelines were set for the study.

1. Please state about your annual family income /status before graduation.
2. Please explain about yourself and your current job experience after graduation
3. Please explain about the how the degree knowledge helped to better perform the functions of the job, promotions, getting a new job etc.
4. Do you believe that "vocational and technical education goes a great way toward lowering unemployment rates among the jobless young in society?"
5. Do you think increase in vocational and technical education opportunities also affect productivity and economic growth of the country?
6. Please explain how insufficient participation in the execution of vocational and technical educational and training policies leads to unemployment.
7. Youth can make a living through vocational and technical education. Explain.
8. Vocational and technical education can help people find employment. Explain.

9. Vocational and technical education encompasses all of the structured and targeted experiences required for job advancement. Agree/Disagree Please explain.
10. Is vocational education the greatest approach to increase a country's wealth? Give your comments.

The information received from the interviews were analysed thematically, following the below process proposed by Flick (2014).

A. Becoming familiar with the data

As Auerbach & Silverstein (2003) noted that firstly qualitative data should be relevant to research's concern mind. Therefore researcher used the following method for the becoming familiar with data:

*I got a job related administration due to the qualification of my degree program and meantime working as HR and Administrative Assistant. Actually it is very good experience to me to gain my target achievement and it supports to continue my higher studies abroad as well. Due to the combination of technology of this degree it was very good and it was the highest advantage of my employment in my organization to make my performances at all the times*

B. Generating initial codes

This step aids in the writing of the thematic analysis in order to present the complex tale of the data in a way that persuades the reader of the researcher's validity and responsibility. (See Table 1)

Table 01: Summarized Details of Respondents

Research Guidelines	Salient points	Themes
<b>Do you believe that "vocational and technical education goes a great way toward lowering unemployment rates among the jobless young in society?"</b>	Yes I believe that even currently the unemployment is reduced but still there are people unemployed which indicates that there is room for development	Vocational and technical education and unemployment
<b>Please explain how insufficient participation in the execution of vocational and technical educational and training policies leads to unemployment</b>	The publicity about the courses and training programs should definitely be improved. If the general public aware the available opportunities to get the vocational education leading towards some definite jobs, there will be more students for the courses [Especially for the NVQ courses]. Having some more students may lead to reduce the unemployment. Further, the facilities to the students and the staff involved should be improved.	Current situation of unemployment
<b>By focusing on the agricultural sector, vocational and technical education and training helps to combat the plague of poor quality of life.</b>	As the Sri Lanka has several lands available for agriculture (but some are not used), the vocational education towards the agriculture field is really good in order to increase the production, more income and hence improve the quality of the lives.	Vocational and technical education and training
<b>Youth can make a living through vocational and technical education. Explain</b>	Today, a considerable portion the youth immediately try to find a way of income after the A/L or even O/L. The most common ways might be - joining to forces, join with a craft level job or become self-employed such as a taxi driver or a small merchant. Apart from the above few, some tries to migrate for a good income. However, if the above said all categories must get more job opportunities with good salaries, if they have any kind of vocational education / skills.	Vocational and technical education and employability

<b>Vocational and technical education encompasses all of the structured and targeted experiences required for job advancement.</b>	Vocational and Technical Education definitely helps to the career development.	Vocational and Technical Education and career development
<b>Do you think “Vocational and technical education has a long way in reducing unemployment among the unemployed youth in the society”.</b>	Yes. But it’s a challenge to grab youths for this because today’s youths are seeking light and white collar jobs.	Vocational and Technical education unemployment
<b>Please explain how insufficient participation in the execution of vocational and technical educational and training policies leads to unemployment.</b>	Yes. Definitely.	Current situation of unemployment
<b>By focusing on the agricultural sector, vocational and technical education and training helps to combat the plague of poor quality of life.</b>	Present content of teaching is not adequate to meet today’s advance technology. Therefore rate of leaving from industry is high because they can’t perform well. Should provide moderate knowledge of theory and fundamental principles equally as well as practical and training before sent to the industrial training. In today’s context industry need self-motivated technical persons not just instruction follows. All level of vocational training programs should include class room sessions and practices. Most of programs not suite for today’s context. Still vocational institutes follow very old syllabuses. It should updated.	
<b>Youth can make a living through vocational and technical education. Explain</b>	Completely agree. But today it is not happening in satisfactory level. There should more programs, training and facility with dignity on agriculture. There should be proper mechanism to find youths from school leaves who specially belong to parents of farmers and agriculture sector.	Vocational and Technical Education and Training
<b>Vocational and technical education encompasses all of the structured and targeted experiences required for job advancement.</b>		Vocational and Technical Education and career development

C. Searching for themes

During this phase, there was a worthy idea to start taking notes for coding that will then go back to in subsequent phases. Then, during the entire study, coding is built and specified. The mind map given in Figure 1 has given the themes of this research.

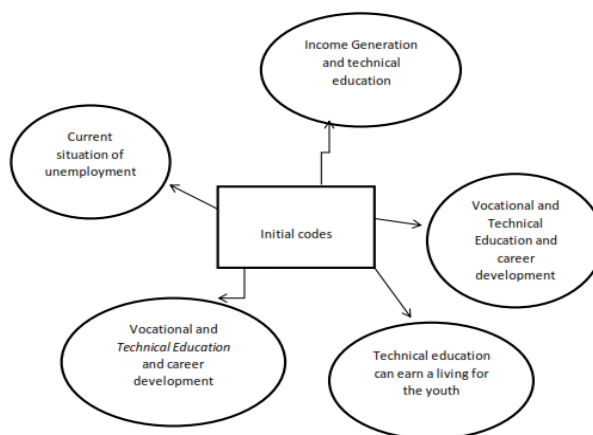

Figure 1: Initial Codes

D. Reviewing themes and defining and naming themes

After reviewing initial codes and transcripts of the interviews, the study has highlighted the main themes as follows.

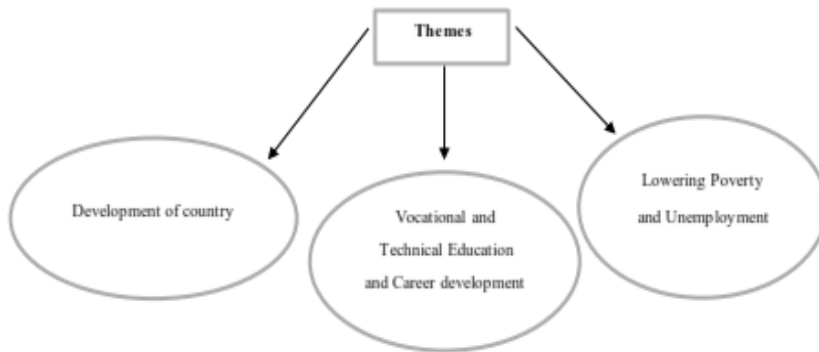

Figure 2: Main themes

**3. RESULTS AND DISCUSSION**

The current study looked at how the technical and vocational education has contributed towards poverty reduction among youths in Sri Lanka and for this purposes as mentioned in the methodology chapter a sample that consisted of thirty two graduates were interviewed and in this section of the research it is thematically analysed qualitative data.

**3.1. Vocational and Technical Education and Career Development**

Out of the participants, 70% highlighted that with the qualification that they have gained on Vocational Education, an individual was able to get a career development such as promotions, salary increments etc. The idea of 20% is that the qualification that they gained does not give any immediate improvement in their career.

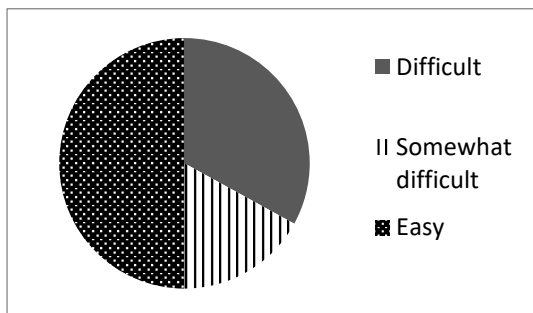

Figure 3: Job employment

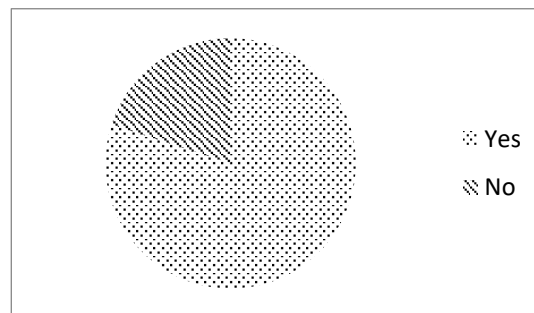

Figure 4: Achievements of qualifications and promotions

**3.2. Lowering Poverty and Unemployment**

One of the themes that emerged from the discussion is unemployment. 50% of the participants in the current study expressed that finding employment of graduation was “*Very Easy*” and for another 33% however it had been “*difficult*” and for 17% of the participants it had been “*Somewhat difficult*”. However it was observed in many responses that there is a notable difference between a graduate from a state university and one from the Vocational University lies in the fact that the vocational graduate

possesses the skill as well as the paper qualification whereas a graduate of a state university in most cases lacks this skill component.

### 3.3 Development of Country

Another theme that emerged from the discussion was the facts that not only are people empowered with the vocational sector but also it helps towards the development of the country.

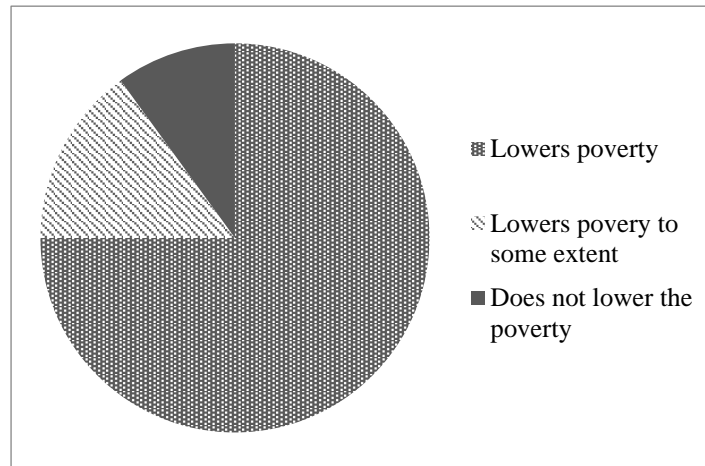

Figure 5: Lowering of poverty and unemployment

It had been stated by many of the participants that many opt for professions such as a craft level job or become self-employed such as a taxi driver or a small merchant and for these type of jobs when due recognition is given not only it helps solving the problem of unemployment but also helps towards development of the country. The data revealed that majority of the participants were from a rural background and came from very poor families with low income levels. There were also a minority who were already employed and followed the degree programmes for enhancement in their career and also in terms of economic benefits. As per their educational backgrounds, it was seen that a vast majority had diverted themselves from the traditional education system and most of the participants reached only the grade 8 standard during their period of schooling.

## 4. CONCLUSIONS/RECOMMENDATIONS

### 4.1 Conclusions

Form the results of the thematically analysed responses, the findings were made according to three important themes derived, namely, vocational and technical education and career, lowering poverty and unemployment, and development of the country. The study as a whole revealed that the vocational education can have a strong impact on reduction of unemployment, especially with the skill one having from the vocational trainings. Based on the results, it can be seen that there is a need to expand the range of vocations to which the degrees are awarded and most specifically in the fields such as agriculture, it could be broadened to other sub areas such as animal sciences, forestry. Then field of food technology could be broadened to food safety and management, trends in food science and video production, beauty culture etc. It was further highlighted from the results that with a skill in a particular vocation and sufficient paper qualification, individuals could secure a sound employment which at the same time financially strengthens them. Hence, the study brought out that when equipped with a sound education in technical and vocational education it creates a sound economic background and also enhances one's career. However, it was revealed from the study that the society needs more awareness on vocational sector and the type of education that one could get from various vocations.

## 4.2 Recommendations

The study revealed that the vocational education helps immensely towards the poverty reduction and development of the country. However due to lack of awareness many do not engage in vocations that secure them employment. For this, it was recommended that through career guidance one could be given awareness on existing vocations that helps to make them sound both economically and academically. In the study it was recommended that there is a need English language courses to be coupled with the degree in order to easily obtain employment, and in this sense vocational diploma or even degree programmes should give more concentration on English competency of participants. Further, it is recommended to draw the attentions of training providers to expand their programmes in the occupational areas such as agriculture, food technology, video production, beauty culture etc. in order to meet future economic challenges.

## REFERENCES

- Adams, A. V., Middleton, J., & Ziderman, A. 1992. *The World Bank's policy paper on vocational and technical education and training. Prospects*, 22(2), 125-140.
- Awan, M. et al. .2011. 'Impact of education on poverty reduction', *International Journal of Academic Research*, 3(1), pp. 659–664.
- Borode, M.. 2011. 'Higher education and poverty reduction among youth in the sub-saharan africa.', *Higher Education*, 3(1), pp. 149–155.
- Burns, R. 2000. *Introduction to Research Methods*. 4th edition. Melbourne, Victoria. Longman Cheshire.
- Flick, U. 2018. *An introduction to qualitative research*. Sage.
- Hartl, M. .2009. 'Technical and vocational education and training (TVET) and skills development for poverty reduction – do rural women benefit?', *FAO-IFAD-ILO Workshop on Gaps, trends and current research in gender dimensions of agricultural and rural employment: differentiated pathways out of poverty*, (April), pp. 1–24.
- Khwaja, A. I. 2004. Is increasing community participation always a good thing? *Journal of the European economic Association*, 2(2-3), 427-436.
- Kurtishi-Kastrati, S. 2013. The Effects of Foreign Direct Investments for Host Country's Economy. *European Journal of Interdisciplinary Studies*, 5(1).
- United Nations Educational, Scientific and Cultural Organisation (UNESCO). 2014. Teaching and learning: Achieving quality for all. *Education for All Global Monitoring Report*.
- Poverty, U.O.H., 2000. poverty report 2000. United Nations Development Programme. New York: UN.

# Delineating Elephant Corridors in North-Western Wild Life Region

B.A. Asika Sewwandi\*, Malani Herath

Department of Town and Country Planning, University of Moratuwa, Sri Lanka

## ABSTRACT

*Continuous shrinking favorable habitat is the identifiable cause of the escalating human-elephant conflict (HEC) in Sri Lanka. Corridor establishment is a widespread tool for conflict mitigation in conservation planning. Referring to the Department of Wildlife Conservation (DWC) policy for mitigating HEC, there should be scientific identification of elephant corridors and the proper establishment. The study aims to develop a method to delineate elephant corridors in Arc GIS while identifying the resistance surface to elephant movements. The study follows the resistance-based connectivity method to delineate elephant corridors. Forest type, Distance from surface water bodies, Distance from main roads and railways, Distance from human settlements, and electrical fences are most commonly used for resistance surface identification. The study facilitates an appropriate method to delineate elephant corridors in Arc GIS which may apply to corridor establishment in the Northwestern wildlife region. The study has concluded that the resistance-based connectivity method in the Arc GIS environment is an appropriate method to delineate elephant corridors in the Northwestern wildlife region.*

**Keywords:** Arc GIS, Circuit Theory, Human Elephant Conflict, Resistance Surface.

## 1. INTRODUCTION

Human-wildlife conflict (HWC) has become a key element in conservation planning and highlighted in global conservation priority. Unplanned human settlement developments and agro land expansion have restricted elephants to small forest patches and disturbed the traditional migratory routes. Habitat loss and fragmentation leads to an increase in Human-Elephant Conflict (HEC). (Leimgruber, et al., 2003) There are types of mitigation measures undertaking for the prevention and mitigation of HEC on a different scale, which only transfer risk from one area to another as a short term solution. (Shaffer, et al., 2019) DWC has identified the shrinking of favorite habitat and, disruption of elephant corridors is a considerable threat to escalating HEC. Elephants are in fragmented forest areas are moving from one forest patch to another for the contentment of their essential requirement such as Food, Safety/Shelter, and social rehabilitation.

Though there are arguments on the effectiveness of the elephant corridor, corridors advance the conservation priorities. (Beier, 1998) “A corridor defines as an area that connects two patches of suitable habitat by passing through a surrounding substance of incongruous habitat.” (Zimmermann, et al., 2009) The ecological importance of elephant corridors is connecting the elephant population, facilitating gene flow, enhance habitat utilization, and expedite safe animal movements. (Mukti, et al., 2016) In sustainable development planning, land-use zoning and conservation planning, ‘corridor’ is a widespread tool. (African Wildlife Foundation, 2017) The range countries of Asia have widely following the elephant corridor as a tool for a long term effective conflict management strategy.

But in Sri Lankan context, the existing method for identification of an elephant corridor depends on ‘collared’ or ‘surveys on elephant signs’ data of the elephant movements. But collaring elephant is an expensive way of elephant movement identification. Hence, elephant signs observations require a long time to identify the general routes of the elephant. There is a need for a cost and time-effective way to the recognition of elephant corridors. Department of Wild Life Conservation has proposed a policy as, scientific recognition of elephant corridors and movement pathways for

---

\* Corresponding Author: E-mail - [asikasewwandiperera@gmail.com](mailto:asikasewwandiperera@gmail.com)



HEC mitigation. The policy identifies as a sustainable measure under the National Policy on conservation and management of wild elephants in Sri Lanka. (DWC, n.d.) It is not identified a scientific method to identify elephant corridor nationally. The National Physical Plan by 2050 has proposed some elephant corridor nationally but mainly align with the corridor conservation proposal in 1949. (NPPD, 2019)

In such a situation, this study attempts to make a significant contribution by overcoming the following limitations noted in emerging researches and current practice. The first one is the gap in the scientific elephant corridor recognition method before development activities and for the fulfillment of the current policy requirement of HEC mitigation by DWC. The second one is the ineffectiveness of cost and time of existing elephant corridor recognition practices. Therefore this study objectives to investigate a scientific method to delineate elephant corridors in Arc GIS and identify the resistance factors for elephant movements.

## 2. LITERATURE REVIEW

Collecting empirical data of elephant movement in a large area, time and economic costs are high. In these intense, model elephant corridors are giving the next best opportunity before the field works. (Koen, et al., 2014) Using modern connectivity science approaches are essential for the proposed or the existing corridor evaluation and help to regulate conservation policies for land managers, planners, and etc. (Cushman, et al., 2010).

Modern ecological connectivity approaches has followed many methods to develop ecological corridors as Individual based movement model (Grimm and Railsback, 2005), Least –cost path (Adri-aensen et al., 2003; Li et al., 2010), Probability of connectivity (Sauraand Pas-cual-Hortal, 2007), Graph theoretic approach and Circuit theory. The least-cost model (Shaffer, et al., 2019) was an advancement in the movement corridor and connectivity research. However, the least-cost path analysis has limitations that the assumption of each individual has perfect knowledge for the select best route. (Christine, et al., 2018) To overcome the limitation of the least-cost pathway analysis, introduced the ‘Graph-theoretic approach. The results of this application are simulating and exploring there are alternative corridors in randomly distributed forest spaces. (Naiara, et al., 2008). Circuitscape approach is a significant achievement in connectivity analysis in conservation planning and a widely applicable tool for mammal corridor delineation. (Christine, et al., 2018) According to the mentioned approaches, the circuit theory-based resistance surface approach is more suitable for corridor delineation.

### 2.1. Principals of Resistance Based Connectivity Model

The research study follows the resistance surface-based connectivity model for delineate elephant corridors using circuit theory. ‘Circuit theory’ (Ohm’s law, 1827: Kirchhoff’s law, 1845) explains analyzing electrical circuits, applying basic rules as Ohm’s and Kirchhoff’s law to a network of components, to calculate the current and voltage at any point. Ohm’s law explains the amount of current, flow through a resistor depends on the applied voltage (V) and the resistance (R).

Circuitscape approach has developed conceptualizing the Circuit board. The interest of the genetic distance of the species represents the landscape as a circuit board. Pixels in the raster layer explains the resistor. Possible resistor generate a chain of gene flow. (McRae, et al., 2007) The least resistors generate the possible route for the elephant movements. The applicability of circuit theory for the prediction of the connectivity requires the set of the spatial dataset in a graph structure. But every small component in the ground condition cannot create a patch-based network-style format. These computer algorithms can simulate millions of cells within a few minutes. (McRae, et al., 2007) This application requires resistance surface for elephant movements. Forest type, Distance from surface water bodies, Distance from main roads and railways, Distance from human settlements and electrical fences are most commonly using for resistance surface identification.

## 2.1. Applications of Resistance Based Connectivity Model

A study in China has applied the circuit theory-based resistance surface approach to delineate the wildlife corridors for elephant and green peacock. The study used a Circuitscape working environment. The objective is to prioritize the wildlife corridors for restore and conservation. They have identified elephant corridors using circuit theory selected land use, roads and terrain as resistance surface and prioritize the existing elephant corridors. (Yijie, et al., 2019). The research study for African elephant; has focused on validating the resistance based landscape connectivity models for delineating the corridor studies. This study has been done through the annual area counts and validates the results through the field surveys. The key finding of this study was the resistance-based connectivity models are a valid approach to predict elephant corridors for the African elephant. (Osipova, et al., 2019)

Canadian study in Ontario applied the prioritized wildlife corridor and alternative corridors using the circuit theory with Circuitscape software for the habitat corridor delineation. The hypothesis was the artificial boundaries influence the output of the result due to bias. The key finding of study is using the buffered area same output as artificial boundary analysis. The study recommended the allowing buffer zones for the randomized habitat data can solve the overestimating resistance on artificial boundaries. (Koen, et al., 2010)

Even though many studies identify the different approaches to delineate the elephant corridor as a conflict management strategy, there are only a few studies on elephant corridor and corridor delineation in the Sri Lankan context. The contribution of this study to the existing studies is investigating a novel method to delineate elephant corridors in Arc GIS using circuit theory. Moreover this study elaborates the resistance factors for elephant movement, addition to land use, roads and terrain and facilitate another example for elephant corridor delineation in a different context.

## 3. MATERIALS AND METHODS

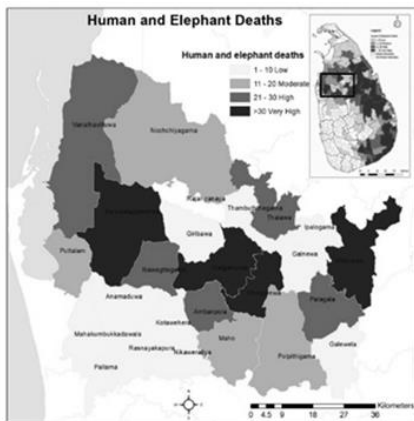

Figure 1: Human and Elephant Deaths Distribution, 2010

### 3.1 Study Area

Anuradhapura, Polonnaruwa, North-Western, Southern, Eastern, and Uva wildlife regions are influencing HEC in Sri Lanka. (T. G. , et al., 2020) (Prithiviraj , 2015). Chasing the elephant in the immediate vicinity using light flares, thunder crackers, or if elephants become aggressive, shout with the shotgun called ‘elephant drives’ is usual in North-Western. (Prithiviraj , 2015) Figure 1 represents the danger of human elephant conflict in this region by four divisional secretariats consist more than 30 human and elephant deaths for a year. The North-western-region has a unique HEC issue due to less availability of protected areas (Leonidas. , et al., 2019) and a highly fragmented landscape. There are only few conserved forests. Distributed cultivated areas, emerged

villages and unauthorized private electrical fences has disturbed many traditional elephant movement pathways from one favorable habitat to another. Elephants have to pass many villages to reach one forest patch to another. There is a value in corridor delineation for the elephant in a fragmented landscape.

### 3.2 Identification of Resistance Surface for the Elephant Movement

The study follows the circuit theory as the conceptualization of elephant movement which means elephants move through the least resistance (Less Barriers) landscape. The factor selection for identification of resistance surface for the elephant corridor is based on the literature Survey.

Forest type, Distance from surface water bodies, Distance from main roads and railways, Distance from human settlements and electrical fences are most commonly using for resistance surface identification. (Hoang, et al., 2010) (Aini, et al., 2017) (Nazimur, 2020). The factor weighting and the category weighting are based on the expertise survey with seven experts. Due to Pandemic condition randomly selected four experts from experienced range officers from case study area and other three expertise who are involving with elephant collaring. The importance of the factor and also the factor category identifies through the concluded expert responses. Selected Thabbowa and Kahalle-Pallekele sanctuaries are selected as core habitat as Department of Wildlife Conservation prioritization. It is experienced there are elephant movements in between these two sanctuaries by field officers.

Table 1: Factor categorization and weighting according to the expertise survey

	Forest			Topography											
	Forest Cover	Forest Type	Forest Status	Distance to road	Distance to surface water	Elevation	Slope	Population density	Distance to Railway	Settlement	Protected area	Floodplain	Soil	Irrigated or non-irrigated agriculture	Tree canopy height
(Rajapaksha, et al., July 2014)	●	●		●	●		●							●	
(Cushman, et al., 2010)				●	●					●					
(Evans, et al., 2020)						●	●			●					●
(Poudel, et al. 2020)				●	●	●	●			●					
(Huang, et al., 2019)	●	●	●				●								
(Neupane, et al., 2019)				●		●	●			●		●			●
(Rameshan & Roy, 2014)	●			●		●				●	●				
(Nazimur, et al.2016)				●	●	●	●			●					
(Puyrav aud, et al., 2016)		●		●	●			●		●			●	●	
(Aini, et al., 2017)			●	●	●	●	●			●	●				
(Hoang, et al.)	●	●		●	●	●	●			●					

### 3.3 Developed Method to Delineate Elephant Corridors

In this stage, it uses the ‘Circuitscape for Arc GIS’ extension tool in Arc GIS 10.7 version, which is based on circuit theory. Resistance surface and core habitats are applied as key inputs. The cumulative current density calculated eight neighboring cells using pairwise mode with lampere (1A) as initial input.

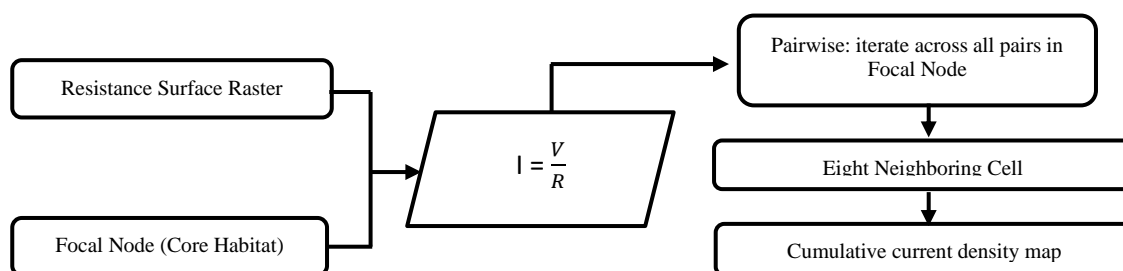

Figure 2: Method of Delineating Cumulative Current Density Map

4. RESULTS AND KEY FINDINGS

Table 2 explains the expert responses to generate the resistance surface for elephant movements. To generate overall resistance surface for elephant movement it requires raster information for each category and each factor. Raster layers generates using GIS data from survey department of Sri Lanka and USGS Earth Explorer website. The maps represented in Figure 5 to 10 show the analytical outputs of the selected criteria for developing a resistance surface map for elephant movements. All the images contain a 20m x 20m pixel resolution.

Table 2: Factor categorization and weighting according to the expertise survey

Factor	Factor Weight	Category	Assigned rank
<b>Forest types</b>	35.8	Dry Monsoon Forest	3
		Savannah	2
		Open and Sparse Forest	1
		Non forest	4
<b>Surface Water Bodies</b>	13.4	0 - 30m	3
		30m - 2000m	1
		2000m - 5000m	2
		5000m - 10000m	4
		Non developed	1
<b>Developed Area</b>	25.5	Developed	3
		High developed	4
		Non developed	1
<b>Main Road</b>	6.7	<100m	4
		100m - 500m	3
		500m - 1000m	2
		>1000m	1
<b>Railway</b>	8.5	<1000m	4
		1000m - 3000m	3
		3000m - 10000m	2
		>10000m	1
<b>Elevation</b>	4.8	<150	3
		150m - 500m	2
		500m - 1000m	1
		>1000m	4
<b>Electrical Fence</b>	4.9	<10m	3
		10 - 2000m	1
		>2000m	2

Note: Assigned rank – 1 – Lowest resistance, Assigned rank – 4 – Highest resistance

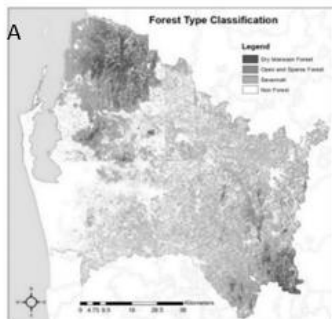

Figure 4: Forest Type Classification

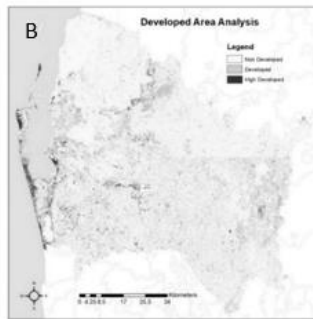

Figure 5: Human Settlement Area

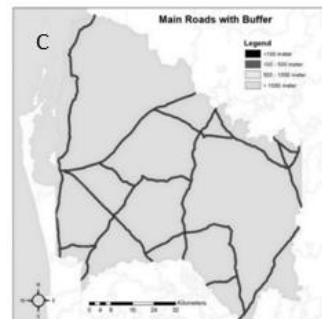

Figure 6: Main Roads with Buffer

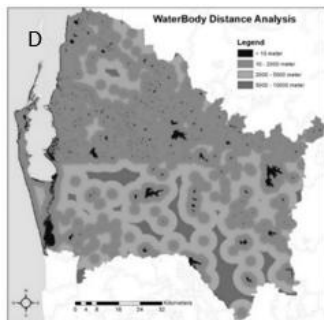

Figure 7: Water body Distance

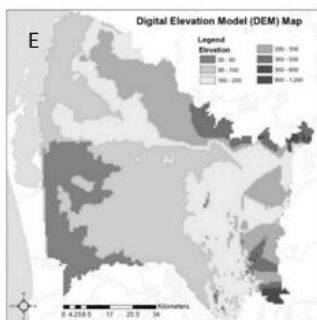

Figure 8: DEM to Meters

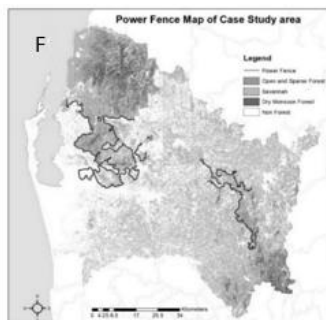

Figure 9: Availability of Electrical Fences

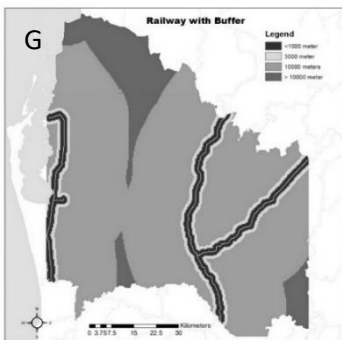

Figure 10: Distances from Railway

Figure 4 explains forest type distribution. The map derived using supervised classification referring to forest distribution by Forest Department Sri Lanka. The ‘KAPPA’ accuracy level of the forest classification is 0.79689 mean in a ‘Good’ category. Figure B illustrates the developed areas. Map derived from NDBI analysis. The KAPPA accuracy value of NDBI analysis is about 0.67129 means acceptable. Figure C explains the major road network analysis using the main road data from the Survey Department of Sri Lanka. Figure D express water body analysis. The Kappa accuracy of NDWI analysis is 0.73710 means have good accuracy. Figure E demonstrates the digital elevation model using contour data by the Surveys Department of Sri Lanka. Figure F explains

Power fences distribution by the DWC, and it applies Euclidean analysis. Figure G expresses the Railway network by the Survey Department of Sri Lanka.

The ultimate goal of this stage is to develop a resistance surface map for the elephant. The calculation is as follows.

$$\text{Resistance Surface} = [(FT_{cw} \times FT_w) + (DA_{cw} \times DA_w) + (MR_{cw} \times MR_w) + (WBD_{cw} \times WBD_w) + (DEM_{cw} \times DEM_w) + (PF_{cw} \times PF_w) + (RW_{cw} \times RW_w)] \quad (\text{Eq.} = 1)$$

Where, FT=Forest type, DA=Developed area, MR=Distance to main road, WBD=Distance to water bodies, DEM=Elevation, PF=Power fence, RW=Distance to railway, CW = Criteria Weight, W=Factor weight

Figure 11 shows the resistance surface map with overlap the elephant caused human deaths, injuries, and property damages in the year 2005. It visualizes the identified resistance area consists many elephants caused damages.

Figure 12 presents the flowing current density between Kahalla and Thabdowna sanctuaries, which means all possible corridors for the elephant movement. Dark color in the middle of the map means the highest density (High accessibility), and white color in the middle map shows the least density (Least accessibility) of current flowing (Elephant movement). Black points visualize the

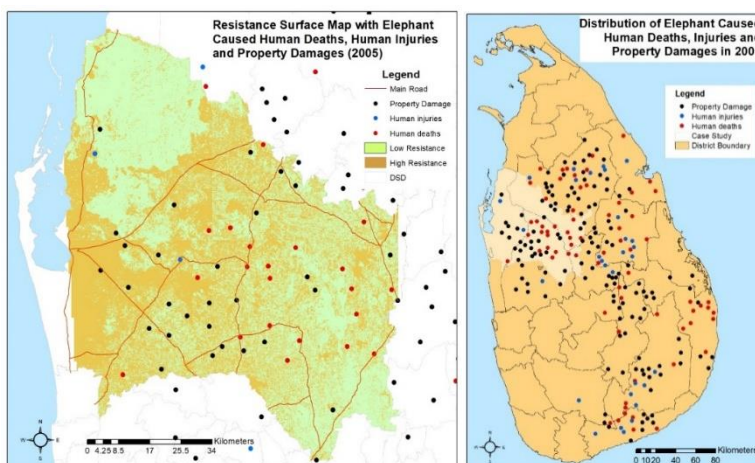

Figure 1130: The Relationship of Resistance surface and the conflicted locations

elephant radio-tracked data overlap with the modeled detected the high accessible area. The radio-tracked data is in between 2008 to 2018 period.

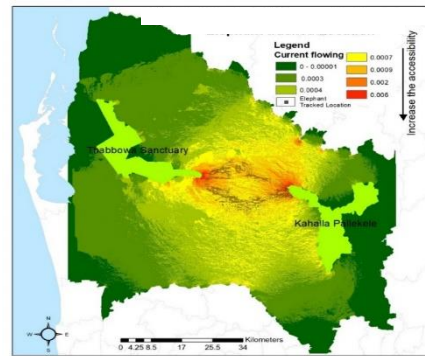

Figure 1231: Modeled Elephant Corridors and Radio Tracked Locations

## 5. CONCLUSION AND DISCUSSION

The study attempts to develop a method to delineate elephant corridors in a fragmented landscape with the identification of significant determinants of elephant movements. For achieving the objectives, follows a resistance-based connectivity approach to delineate elephant corridors.

Study eliminates the resistance-based connectivity method in the Arc GIS environment as an appropriate method to delineate elephant corridors in the Northwestern wildlife region. The model results compromise the 0.67 of KAPPA accuracy with elephant radio-tracked data, overlap with the general route identification of DWC, and expert recommendations with the appropriateness.

DWC has identified the Kahalle-Pallekele and Thabowwa sanctuaries as the wildlife protected area except the Wilpattuwa National Park for the Northwestern wildlife region as the core habitat for elephants. This study recognizes the elephant corridor areas rather core habitat may protect for elephant movement in the Northwestern wildlife region.

Moreover, this study eliminates Forest type, developed area, distance to surface water bodies, Distance to main roads and railways, Power fences, and Elevation influence on creating a resistance surface to elephant movements based on the theoretical analysis.

Existing studies have practiced Circuitscape 4.0 software for analysis the elephant corridors align with circuit theory, and this study is developed only in an Arc GIS-based working environment. This study adds alternative value for existing studies, providing another example of study using resistance-based connectivity modeling for elephant corridor delineation. This study provides benefit to fulfill the Sri Lankan context research gap on the investigation of a corridor delineation method in a resistance-based connectivity modeling.

Due to computation capacity limitation, the result could able to simulate only for the 30m resolution and applied for only two main sanctuary to evaluate elephant corridors. For the validation, the delineated elephant corridors used radio-tracking information of published research due to the unavailability of enough collected elephant collared data for the selected area. When selecting the power fence as a resistance factor for elephant movement, only include power fences which maintain by the DWC. According to the wildlife officers, there are many unauthorized private power fences in the case study area. Rather than selected factors, there can be some other factors influence elephant movements. And also there is a limitation on collecting expertise responses due to travel restrictions. Selecting all possible core habitat for delineating elephant corridors and selecting expertise from more experienced may be value-added for further studies. Detecting all influencing resistance factors will generate more accurate outputs, and the resolution and the accuracy of the preliminary analysis may influence the delineated corridors. Recognition of elephant corridor is more important for managing corridors for the elephant movement and minimizing confliction of human and elephant while their movements.

## REFERENCES

- African Wildlife Foundation, W. L. C., 2017. <http://www.awf.org>. [Online].  
 Beier, P., 1998. Do habitat corridors really provide connectivity?. *Conservation Biology*.  
 Christine, M. A., Gray, M., Meredith, L. M. & Theobald, D., 2018. Circuit-theory applications to connectivity science and conservation. *Conservation Biology*, pp. 1-11.

- Cushman, S. A., Chase, M. & Griffin, C., 2010. Mapping Landscape Resistance to Identify Corridors and Barriers for Elephant Movement in Southern Africa. *Spatial Complexity, Informatics, conservation*.
- DWC, D. o. W. C., n.d. *National Policy on conservation and management of wild elephants in Sri Lanka*, s.l.: s.n.
- International Elephant Foundation, 2014. *Home/conservation/Archeive Projects/Elephant corridors in North Western region*. [Online] Available at: <https://elephantconservation.org>
- Koen, E., Bowman, J., Sadowski, C. & Walpole, A., 2014. Landscape connectivity for wildlife: development and validation of multispecies linkage maps.. *Ecological Evolution*, pp. 626-633.
- Koen, E. L., Garroway, C. J., Wilson, P. J. & Bowman, J., 2010. The Effect of Map Boundary on Estimates of Landscape Resistance to Animal Movement. *PLoS ONE*.
- Leimgruber, P., Gagnon, J., Wemmer, C. & Kelly, D., 2003. Fragmentation of Asia's remaining wildlands: implications for Asian elephant conservation,. *Animal Conservation*, pp. 6: 347-359..
- Leonidas. , . A., Papakonstantinidis & T.G. Supun , P. L., 2019. Analysis of Human-Elephant Conflict in Sri-Lanka by The Win-Win-Win Papakonstantinidis Model. *Economics, Business and Entrepreneurship* , pp. 1-9.
- McRae, B., Beier & P., 2007. Circuit theory predicts gene flow in plant and animal populations. *Proceedings of the National Academy of Sciences*.
- Mukti, R., Sukumar & Raman, 2016. *Elephant Corridors in othern Western Bengal*, s.l.: Gajah 43.
- Naiara, P., Timothy & H, K., 2008. Beyond the least-cost path: Evaluating corridor redundancy using a graph-theoretic approach. *Landscape Ecology*.
- Osipova, L. I. et al., 2019. Validating movement corridors for African elephants predicted from resistance-based landscape connectivity models. *Landscape Ecol.*
- Prithiviraj , F., 2015. Managing Elephants in Sri Lanka. *Ceylon Journal of Science*, pp. 1-11.
- Shaffer, L. J., Kapil , K. K., Jamon Van, . D. H. & Naithani, J. K., 2019. Human-Elephant Conflict: A Review of Current Management Strategies and Future Directions. *Frontiers in ecology and evaluation*.
- Shaffer, L. J., Kapil, K. K., Jamon , H. V. D. & Naithani, K. J., 2019. Human-Elephant Conflict: A Review of Current Management Strategies and Future Directions. *Frontiers in Ecology and Evaluation*.
- T. G. , S. L. P., A. W. , W. & Prithiviraj , F., 2020. Human-Elephant Conflict in Sri Lanka: Patterns and Extent. *Gajah*.
- Talukdar, N. R. et al., 2020. Habitat suitability of the Asiatic elephant in the trans-boundary Patharia Hills Reserve Forest, northeast India. *Modeling Earth Systems and Environment* .
- Yijie, Y. et al., 2019. Identifying multispecies dispersal corridor priorities based on circuit theory A case study in Xishuangbanna, Southwest China. *Geogr. Sci*.
- Zimmermann, A. et al., 2009. Community-Based Human- Elephant Conflict Management in Assam. *Gajah* 30.

# Job Market Opportunities via Social Networking Sites

A.W.K.G. Wijesingha<sup>1</sup>, L.H.D.L. Ranasuriya<sup>\*2</sup>

<sup>1</sup>Department of Education and Training, University of Vocational Technology, Sri Lanka

<sup>2</sup>Department of Language Studies, University of Vocational Technology, Sri Lanka

## ABSTRACT

*To combat the issues that have arisen of Covid-19, especially to deal with the economic crisis, Youth and citizens in Sri Lanka, have adopted various measures which are to become an online entrepreneurs. As a result, recently, there has been an extensive interest to gain foreign investment into the country using different Social networking sites. This study attempts to extract the dimensions that yield to undergraduates' reliance on social networking sites and measure its effect on market trends by surveying a sample of University undergraduates in the University of Vocational Technology as users of social networking sites. The convenience sampling technique was used for data collection from 50 participants of university undergraduates. With the utilization of mixed methodology, research incorporated with qualitative data analysis through interviews as well as quantitative gathering through questionnaires. Thus data analysis followed descriptively and content analysis. The unique value of this research is that its contribution to understanding the perception and attitude of undergraduates avenues regarding the job market as well as social networking sites usage as a prompting tool for getting professional contacts in the job market. Therefore, this research aims to identify whether undergraduates' reliance on social networking sites contributed to job market opportunities. These research findings indicated that social networking sites positively address job market opportunities.*

**Keywords:** Economic development, Social Networking Sites (SNS), Undergraduates.

## 1. INTRODUCTION

For many people, looking for a job is a major life battle. After graduation, many people, particularly young people, have high hopes and look for new tools to assist them find work. Social networking sites are tools designed to assist users in finding their dream jobs, particularly well-paying ones. Nowadays, society 'Online social network or social networking site has been rapidly growing as a central communication channel. Its emergence has shortened the distance between folks by furnishing them a platform for social interaction and communication. It allows individuals to stay connected with others effortlessly unrestricted by time and geographical boundaries. Apart from that, the exceptional popularity of online social networks among the public has driven its deployment into today's business world. Such entrepreneurs who greatly relied upon an E-Commerce system can be known as cyber entrepreneurs. Since setting up a business via an online social network is not complicated, it has gradually become a trend (Lau et al., 2011, p. 4). Furthermore, people (especially graduate students) are using social networking sites like LinkedIn to seek for appropriate jobs and establish professional ties. Moreover, some researchers acknowledged that graduate students looked for jobs in four ways: through personal relationships, university intermediaries, internships, and formal job applications. It discovered that employing personal contacts resulted in a higher rate of job acceptance by candidates (Jensen, 2015). Therefore, in terms of job searching, social networking sites like LinkedIn and Facebook allow us to make relationships that may be useful in the future in the world of graduates. Job boards provide information about open opportunities for this purpose, whereas social networking sites provide a platform for engagement with job seekers, helping them to make better-educated employer selections (Wadhawan and Gupta, 2019). Furthermore, by utilizing social networking sites, businesses can ensure amazing efficiency in their selection and recruitment processes (Hasan, Salehin and Islam, 2018, p.1). Due to its phenomenal popularity, several researchers have conducted studies on its effectiveness as well as undergraduates' reaction, satisfaction and continuance intention to adopt it (Lau et al., 2011, p. 4).

---

\* Corresponding Author: E-mail - [dilininirasuriya@gmail.com](mailto:dilininirasuriya@gmail.com)



A study conducted by Granovetter (as cited in Ioannides & Lounsbury, 2004) encourages sociologists to go beyond emphasizing “the embeddedness of action in social networks” and claims that a “concentration on network mechanics alone” is insufficient to “lead us toward the more complex synthesis that we seek in understanding the economy”(p. 31). In light of this, it appears that distinguishing between the motives that prompt individuals to interact in social networking deserve attention in future research (Ioannides and Lounsbury, 2004). In light of this, the researcher planned to conduct an exploratory study to research undergraduates' reliance on social networking sites and the way it affected the duty market during the Covid-19 period. With the advance of Internet connectivity and therefore the increased popularity of smartphones, social network sites (SNS), like Facebook, Twitter, and Instagram, are used almost constantly (Wang et al., 2021). Furthermore, the combination of social networking sites has the potential to revolutionize the traditional way of conducting business and create innumerable opportunities for the business (Lau et al., 2011, p. 4). As a result, for the purposes of this study, the researcher investigates job market opportunities through social networking sites.

### **1.1 Research Questions**

1. Which social networking sites are used by undergraduates to seek job market opportunities?
2. What motivate undergraduates to use social networking sites?
3. How social networking sites helped to seek job market opportunities?

### **1.2 Research Objectives**

1. To identify which social networking sites are used to seek job market opportunities.
2. To identify what motivates undergraduates to use social networking sites.
3. To identify how social networking sites helped to seek job market opportunities.

## **2. METHODOLOGY**

### **2.1 Research Design**

This study employed a descriptive survey research design. Sekaran & Bougie (2013) notes that descriptive research is frequently used to collect data that describes the characteristics of people, events, or situations. Descriptive research is either quantitative or qualitative in nature (p.97)”. Therefore researcher adopted a mixed method approach.

### **2.2 Settings and the Sample**

Sample was selected from University of Vocational Technology as a representation of social networking sites users. For the study, a sample of 50 participants were chosen. Study done by Brown recommended that 40–60 participants are adequate, with far fewer perhaps actually being needed (as cited in Ha, 2014). In order to choose the sample size, the base was convenience sampling. Study done by (Taherdoost, 2016), emphasized that Convenience sampling often helps to overcome many of the limitations associated with research. Using friends or family as a sample, for example, is less difficult than targeting unknown individuals. In this present study researcher had to use convenience sampling technique due to the constraints such as accessibility to the population, lack of time and resources. In addition, Sekaran and Bougie (2013) stated that “convenience sampling is most commonly used during the exploratory phase of a research project and is possibly the best way to obtain some basic information quickly and efficiently.” (p.252).

### **2.3 Instruments**

The study employed a mixed-method research design, so the following instruments were employed: interviews and questionnaires, in order to conduct a comprehensive analysis of research questions, thereby improving reliability and validity. The researcher used the 4 point Lickert scale statements. According to Ionescu (2018), a four-point Likert scale is one on which the respondent is asked how strongly he or she agrees or disagrees with a statement. The Likert scale was given four points (strongly agree, tend to agree, tend to disagree, and strongly disagree) to eliminate the possibility of the

respondent sitting on the fence' by selecting the middle 'not sure' category, which would make the response ambiguous. Furthermore, the researcher pointed out that the four-point Likert scale was used because he wanted the respondent to express a clear opinion on the statements, which enabled the researcher to clearly determine whether the respondent was more or less of a risk seeker or more or less risk-averse in certain situations. Moreover, participants were also asked to identify other factors that were not included in the questionnaire but which they deemed important. The present study was mainly based on qualitative data, as the focus was on obtaining views. Taking these factors into account, the researcher used semi-structured interviews in which questions were prepared to steer the interview towards the satisfaction of study objectives, while extra questions were posed during the course of the interviews. Sinhala interviews have been translated into English, while English interviews have been transcribed straight. However, semi-structured interviews based on these generated a strong outcome with ten participants in this study.

**2.4 Data Analysis**

The study gathered a lot of data from the semi-structured in-depth interviews, and the researchers needed an effective way to organize and analyze this data in order to use it in the research. As a result, for the interview, content analysis was applied. Quantitative data for this study were analyzed using descriptively.

**3. FINDINGS**

Table 1: Socio Demographics of the Respondents

Variable	Responses		
	<b>Age</b>	<b>20-25</b>	<b>26-30</b>
	24(48%)	25(50%)	1(2%)
<b>Gender</b>	<b>Male</b>	<b>Female</b>	
	29(58%)	21(42%)	
<b>Which academic year?</b>	<b>1<sup>st</sup> year</b>	<b>2<sup>nd</sup> year</b>	<b>3<sup>rd</sup> year</b>
	9 (18%)	21(42%)	20(40%)

As can be seen in Table 1, among the 50 participants who took part in the questionnaire majority fell in to the 26-30 age category and as for the gender distribution it was accounted 58% for Male. Another demographic factor researcher looks at is respondents' academic year at the university, there was a majority included in 2nd year which is 42%.

Table 2 depicts that Facebook was the top ranked social networking site (SNS) and obtained 84% of among all participants. LinkedIn was the second with 76%. YouTube and Integra third, fourth positions in social networking sites used by undergraduates with the percentage of 66% and 48%.

In the interview session, the majority of participants agreed that Facebook groups help them stay up to date on job opportunities and, in particular, when scheduling group meetings for new product launches and other discussions related to current part-time jobs and innovative ideas, and help them receive criticism or feedback from other people for existing products, so it was evident that participants showed a keen interest in using Facebook as a social networking site. Some admitted to being concerned about putting personal information on the internet, but they used Facebook to find job opportunities and to create Facebook pages. The empirical evidence that followed provided a rich foundation for why certain people enjoy Facebook to see job market opportunities.

Table 2: Summary of social network sites used by undergraduate to seek job market opportunities

Which social networking sites primarily used to seek job market opportunities?	Yes	
	Frequency	percentage
<b>Facebook</b>	42	84%
<b>Twitter</b>	32	64%
<b>You Tube</b>	33	66%
<b>LinkedIn</b>	38	76%
<b>Instagram</b>	24	48%

A study done by (Wang et al., 2019) pointed that as a practitioner, through the Facebook fan/business page, you'll be able to put the photos, videos, articles, links, discussions, events, news, offers, and every one sorts of information associated with your business in one place, your Facebook business page. Your customers will get updated with the most recent offers and news associated with your products/services. You'll directly interact along with your customers, elicit their feedback/suggestions about your products/services and also create a pre-launch offer on your page to check your product or service with them before launching it on the market. You'll thereby get genuine feedback from your loyal customers. Furthermore, all participants admitted to using more than one or two social networking sites to search for job opportunities, as evidenced by the following.

Participant 2: "I'm interested in a variety of social networking sites. Currently, I involve in English medium teaching as it is taken as a service so I used the Facebook page and used LinkedIn to update my experience, qualifications and I'll update regularly. I have linked all my sites together and yes, I take an income. I think as a result of my LinkedIn many of them hired me for jobs".

According to a study conducted by Kimberly, Jeong, and Lee (as cited in Melani & Andrew, 2017), only a few students are aware of the academic and professional networking opportunities provided by the sites. Therefore as a second objective, researcher tried to get an overall picture about the motive factors.

Table 3 shows the responses to the statement of 'What motivate you to use social networking sites?'

Table 3: What motivate undergraduates to use social networking sites?

Statements	%	(1)	(2)	(3)	(4)
<b>I want to show off my experience</b>	%	26	58	16	0
<b>I want it for create professional contacts</b>	%	34	52	14	0
<b>I can use it as a CV (Curriculum Vitae)</b>	%	30	60	06	4
<b>I want to seek job vacancies</b>	%	36	48	14	2
<b>I can use to take rewards (eg. job promotions)</b>	%	34	54	12	0
<b>I want to share my knowledge</b>	%	30	56	12	2
<b>I can use it to gain knowledge</b>	%	42	50	08	0
<b>I use it to solve my problems with experts</b>	%	36	42	18	4
<b>I use it for entertainment</b>	%	36	42	14	8
<b>I use it for make money</b>	%	36	50	12	02
<b>I use it as a market place</b>	%	34	54	10	02

During the interview, some admitted that they created social networking sites primarily to seek information, share information, and opinions, and to use as a representation of public figures for entertainment purposes. While some have directed their attention toward looking for job vacancies, making professional contacts, and serving as a marketplace for various needs, others have directed their attention toward entertainment. With respect to the questionnaire responses, the motivation factor for using social networking sites is to gain knowledge, use it as a market place, take rewards (e.g. job promotions), share knowledge, create professional contacts, make money, seek job vacancies, use it as a CV (Curriculum Vitae), solve problems with experts, and for entertainment. Instagram clearly plays a major role as a social networking site for knowledge co-creators, as evidenced by the study conducted by (Gon, 2021), which acknowledged that on Instagram, hashtags play a key role in looking for topics and contributing to communities' discussion through data that's tagged with a particular hashtag. Users typically provide a protracted list of hashtags (i.e., a maximum of 30 hashtags within the comment section) so as to look on a public timeline search, and using hashtags, they'll identify people with similar interests and make more connections, co-creating new knowledge. Some respondents provided an in-depth understanding of the purposes of using social networking sites and the motivations behind it, as evidenced by the following interviewee response.

Participant 4: I used Facebook, Twitter, Instagram for making a sponsorship with celebrities likewise other than that Facebook, Twitter used for advertising purposes and to make business partnership, likewise LinkedIn profile, YouTube social network sites used for my businesses advertising.

Table 4: How social networking sites helped to seek job market opportunities

Statement	%	(1)	(2)	(3)	(4)
<b>By creating a platform for professional contacts</b>	%	36	52	12	0
<b>Create a discussion forum with expertise</b>	%	32	42	26	0
<b>To connect with other social sites</b>	%	22	64	14	0
<b>Make comfortable platform to interact with others</b>	%	20	62	18	0
<b>To recognize potential employers</b>	%	36	42	16	6
<b>Make platform to post a resume</b>	%	18	58	20	4
<b>As a search engine</b>	%	34	52	14	0

According to questionnaire responses, social networking sites aided the majority of people in their job search by connecting with other social sites, acting as a search engine, providing a comfortable platform to interact with others, recognizing potential employers, providing a platform to create a resume, and providing a platform for professional contacts.

However, some participants admitted to having a website and using it in conjunction with their Facebook page to promote their business. In the interview session some were approved it directly by pointing out how social networking sites helped to create job market opportunities

Participants 1: I used social networking sites like Facebook by creating a Facebook page to promote my products through advertisements in local as well as foreign markets, it helped me to fame my product and brand, it also helped to the enhancement of buyers and community base.

Some participants also acknowledge that social networking sites are free to use, which can also be viewed as a motivator, and conclude that understanding them allows them to gain more followers and reach out to a wider range of consumers through status updates, chats, groups.

It further evident by following empirical evidence that Millions of people review products and services directly via social media sites using video through YouTube, which in many cases is then shared and disseminated via various other social media websites (Kumarasamy & Srinivasan, 2017). The statements that follow covered various perspectives of participants.

Participant 5: "I used LinkedIn, and it assisted me in finding work and advancing my career."

The participant also stated that she was also motivated by YouTube and from which she wants to start a living. It was stated that although it does not help in finding job opportunities, it seems to pave the path to earning a living.

Participant 3: "Up to now, LinkedIn has aided in the application process for job openings. I was hired because they instructed me to submit my CV for this position as well, and there was a trend where they came to seek our profile and download our CV, so we could communicate with experts on our issues and get a solution. If you are in a hurry for a job, you can apply by sharing the position on social networking sites. You can add people and communicate with them, and communication in English isn't necessary (it's not difficult) because it provides suggestions."

Some participants reasoned that social networking sites could be used to find freelance work. Furthermore, they admitted to using LinkedIn to find and follow new companies relevant to their field of study, as well as to gain insight into how organizations work and who works in such organizations.

In addition, some participants concluded that they joined LinkedIn in order to connect with researchers in accordance with their area of interest.

#### 4. CONCLUSION

According to a study done by (Nayan et al., 2021), Malaysian graduates can venture into cyber-security analyst positions, innovate IoT tools and solutions, or be online retail consigners. They can also be content creators for Instagram, Twitter, and Facebook for companies that need their services, do freelance copywriting and editing for new or traditional companies, become social media influencers, become YouTube personalities, or assume the role of digital entrepreneur. As a result, they will not rely heavily on collaboration with the government or the private sector. Furthermore, they have the ability to create additional job opportunities for others. In the current situation, it was discovered a positive intervention aimed at establishing job market opportunities was observed to be directed at undergraduates via social networking sites. Many participants were discovered to be acting as job seekers on social networking sites, while others were directing their efforts toward producing services and products, as well as strengthening the economic aspect, and still others were just beginning to learn and use. The study's overall findings revealed that social networking sites contributed to job market opportunities from an undergraduate perspective. The study also revealed that a majority of the participants acknowledged that by creating a platform that serves for professional contacts, as a search engine, and as a comfortable platform to interact with others, social networking sites helped them to seek job market opportunities.

#### REFERENCES

- Gon, M., (2021). Local experiences on Instagram: Social media data as source of evidence for experience design. *Journal of Destination Marketing & Management*, 19, p.100435.
- Ha, E., (2014). Attitudes toward Video-Assisted Debriefing after simulation in undergraduate nursing students: An application of Q methodology. *Nurse Education Today*, 34(6), pp.978-984.
- Hasan, M., Salehin, M. and Tariqul Islam, M., (2018). Determinants of Graduate Students' Usage of Online Social Media as a Job Searching Tool: The Changing Landscape of Labor Market in Bangladesh. *Review of Public Administration and Management*, 06(01).
- Ioannides, Y.M. and Datcher Loury, L., (2004). Job information networks, neighborhood effects, and inequality. *Journal of economic literature*, 42(4), pp.1056-1093.
- Ionescu, O., (2018). Risk behaviour and the financial auditor—A study of gender differences.
- Jensen, J., Reevaluating Social Networking Sites for Job Hunting.
- Lau, C.K., Chim, W.H., Kam, G.L et al. (2011). *Factors affecting undergraduates' involvement in entrepreneurial activities through online social networks (Malaysia context)* (Doctoral dissertation, UTAR).
- Melani, A. and Andrew, A., (2017). Social media and academic performance of undergraduate students. *International Journal of Research*, 4(14), pp.3449-3462.
- Nayan, S., Shafie, L.A., Chulan, M. et al (2021). Graduate Employability and Digital Entrepreneurship in the Era of IR 4.0. *Jurnal Intelek*, 16(1), pp.158-165.
- Sekaran, U. and Bougie, R., (2019). *Research methods for business: A skill building approach*. John Wiley & sons.
- Wadhawan, S. and Gupta, N., (2019) A Comparative Study on Job Search Behavior of Job Applicant towards Social Recruitment.
- Wang, H.Y., Wang, J.H., Wang, H.W. et al. (2021). Factors Influencing Intention of Facebook Fans of Companies to Convert into Actual Buyers. In *Research Anthology on Strategies for Using Social Media as a Service and Tool in Business* (pp. 357-381). IGI Global.
- Wang, M., Xu, Q. and He, N., (2021). Perceived interparental conflict and problematic social media use among Chinese adolescents: The mediating roles of self-esteem and maladaptive cognition toward social network sites. *Addictive Behaviors*, 112, p.106601.

# Establishment of an Energy Baseline: A Case Study on Possibility of Transforming University College of Jaffna (UCJ) to Near Net Zero Energy Building

Ravindra Koggalage<sup>\*1</sup>, Somasundaram Thuvaragan<sup>1</sup>, S.R.M.P. Seneviratne<sup>2</sup>

<sup>1</sup>Department of Electrical and Electronics Technology, University of Vocational Technology, Sri Lanka

<sup>2</sup>Department of Quantity Surveying, University of Vocational Technology, Sri Lanka

## ABSTRACT

*Energy consumption in the world has been increasing over the past few years with rapid development taking place. High energy consumption directly relates to the economy of a country and it impacts the environment negatively. Thus, it is important to focus on energy conservation to reduce energy costs and environmental impact. In order to do this managing, the energy and the other needs in buildings efficiently is highly essential. This report is basically a study on transforming the University college of Jaffna (UCJ) into a near-net zero energy building. This report describes the basic steps involved in an establishment of an energy baseline and the way involved in an energy audit for a commercial building to optimize its energy usage.*

**Keywords:** Net Zero Energy Building, Solar Power, Wind Energy.

## 1. INTRODUCTION

In Sri Lanka, most of the electricity is used to cool the space. The power consumption of air conditioning equipment accounts for 46.79% of the total power supply, which has been demonstrated in this project. Building energy consumption can be optimized by improving the efficiency of equipment or building components (such as building skins). Many studies emphasize the possibility of saving energy by making small improvements to the constructed environment. Therefore, almost everyone is focused on reducing energy use in the building sector through such improvements.

Due to the oil crisis of the 1970s, most developed countries focused on reducing energy consumption to save energy. Energy savings are achieved by reducing energy from the demand side and looking for other energy sources such as renewable energy.

## 2. BACKGROUND

In today's world, most educational institutions are beginning to take various steps to reduce the energy consumption of their facilities. For such large universities / buildings, it is especially difficult to limit or reduce energy consumption due to its complexity. To solve this problem, some suggestions have been made to develop some practical solutions to improve the energy efficiency in the building. The areas are to be covered by conducting an Energy Audit for UCJ are; walk through audit, utility bill data, direct (face to face) interviews with the authorized people of each building, nominal value measurement using power analyzer.

Finally, short-term and long-term implementations are provided by studying the process of developing and implementing energy management systems, assessing energy efficiency, and at the same time converting buildings to near net zero.

## 3. PROBLEM STATEMENT

Since the Industrial Revolution, world temperatures have risen over the last two centuries. This is a major problem as rising temperatures lead to climate change and require the use of various external

---

\* Corresponding Author: E-mail - [koggalage@yahoo.com](mailto:koggalage@yahoo.com)

cooling systems to reduce heat. The last sentence raises another question. Energy resources are declining rapidly, so these resources should be properly managed for the future. Therefore, my goal is to choose UCJ as a model and study how this building transforms into a building with near net zero energy consumption.

#### 4. OBJECTIVES AND SCOPE

The objectives of the study are; 1. To establish a baseline for electrical energy use. 2. To identify the areas for energy consumptions and 2. To investigate the ongoing exist system to maximize the efficiency by reducing the waste of energy usage.

The main goal of the project is to propose effective UCJ energy efficiency assessment methods and thereby solutions to improve energy efficiency. This project has several areas of work. It is about investigating and determining how UCJ uses energy and how much, where and how it is used, and identifying energy conservation opportunities. This project calculates the energy consumption of the UCJ building, calculates how to use engineering technology to reduce energy consumption through effective processes, makes suggestions through analysis, and averages considering the payback period. The purpose is to make proposals while minimizing energy loss.

#### 6. METHODOLOGY

As shown in Figure 1, the purpose of this chapter is to explain the methodological framework used to achieve the project goals and main objectives. One is to carry out an energy test. Next, analyze the utility cost data and set the energy utilization index. A detailed energy audit is required because an energy baseline needs to be established. Dialux-Evo software should be used for lighting simulations to validate the lighting system. Then, in the process, it is necessary to propose energy saving opportunities.

The main goal of the project is to analyze the energy consumption of UCJ buildings through walk-through energy audits, optimize the energy consumption of buildings and establish a baseline. Use the computer simulation tool (Dialup Evo) to visualize the lighting system and the building management system simulation software (EDGE software) to influence the energy consumption of the building envelope.

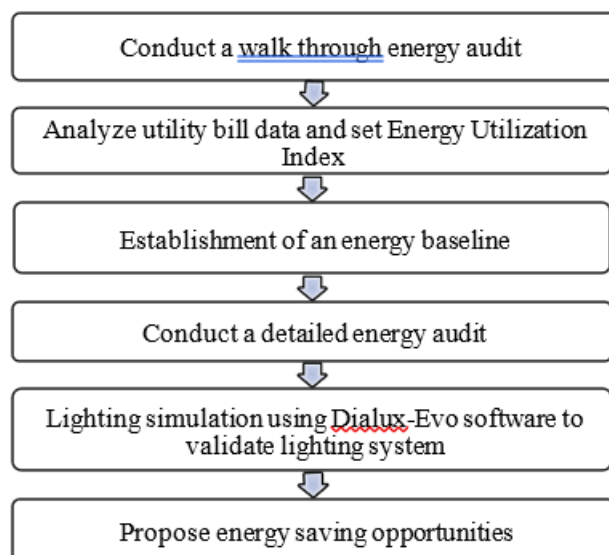

Figure 1: Methodology

The steps of analyzing utility bill data are used to identify the characteristics of energy systems and energy usage patterns in buildings. The standard billing unit for electricity is kilowatt-hours or kilowatt-hours. It is a measure of the intensity or ratio of energy use multiplied by the length of time used ( $kW \times \text{time} = kWh$ ). Since primary energy is considered electricity, energy use is considered the power consumption of the building. We analyzed electricity prices for the 24 months from 2016 to 2017. In addition, we perform a cost-benefit analysis to provide energy-saving recommendations for selected buildings. Therefore, appropriate research is used to achieve these goals. First, we calculated the data by a walk-through audit on the UCJ site, and collected and collected some necessary data. The next step is to use the source and distribute the questionnaire to students who have a reasonable level of knowledge about the subject and comment on the prepared questions with the required details. Finally, the recommended instruments were used and relevant data was collected for a detailed review.

## 7. RESULTS

### 7.1. Appliances Consumption Details

Table 1, gives the energy consumption by appliances in one month. The highlighted red cells indicate the highest power consumers in this building over a month. And in this instance, the air conditioners and machineries which seem to be in high use. Therefore, highly focused to use less energy for air conditioners and machineries while transforming this building into near net zero energy building.

Table 1: Appliances Consumption Details

Appliance Name	Usage per day (KWh)	Days per week used	Per week usage (KWh)	Per Month usage (KWh)	% of Total usage
Fans	27.72	5	138.6	554.4	4.41%
Air conditioners	294.12	5	1470.6	5882.4	46.79%
Soffit mounted CFL	42	5	210	840	6.68%
Fluorescent Light	28	5	140	560	4.45%
Mirror lights	1.484	5	7.42	29.68	0.24%
Multimedia projector	51.8	5	259	1036	8.24%
Exhaust fans	4.8048	5	24.024	96.096	0.76%
Machinery	125.58	5	627.9	2511.6	19.98%
Motors	53.144	5	265.72	1062.88	8.45%
<b>Total monthly usage (KWh)</b>				12573.056	

The unit charge and fixed charge rates are shown in Table 2. According to the meters the monthly electricity usage was calculated and the cost was calculated using percentage value.

Table 2: Unit Charges

Time of Use (TOU)	Unit Charge (Rs. / kWh)	Fixed charge (Rs. /month)
Peak (18.30-22.30)	26.6	3000
Day (5.30-18.30)	21.8	
Off -peak (22.30-05.30)	15.4	

### 7.2. Energy Saving Opportunities

This section focuses on the concept of payback period which is used eminently in economic analysis for project appraisals.

Heating, Ventilation, and Air Conditioning (HVAC) system and lighting were considered as the main energy consumers of this building thus, individually for each of these systems with thorough review of the literature new technologies and operating methods were selected. For these selected improvements, the energy savings were calculated. Savings obtained in energy units were then converted into monetary value by simply multiplying the energy savings in Watts by tariff charge per unit. Then, the cost to purchase and implement such suggested systems were calculated using actual prices of the systems. Using both energy savings and the investment cost the payback period was calculated using equation 1 given below. Payback Periods between two to five years are usually implemented.

$$\text{Payment Period} = \frac{\text{Investment}}{\text{Savings}} \quad (\text{Eq: 01})$$



### 7.3. Utility Bill Data Analysis



Figure 2: Annual electricity consumption over the years 2016-2017

As identified according to Figure 2, the electricity consumption in year 2017, is greater in months of April, May, June, August, October, November and December than 2016 electricity consumption. Both March and August consumptions are greater than other months. The reason for that variation is mainly due the increase in temperature. Also it is observed as the variation pattern of monthly consumption is nearly same in two years. From the graph the same pattern electricity usages for next years can be expected as forecasted.

Figure 3 shows the amount of unit were produced by solar panel and transferred to the CEB grid in 2016 year. The maximum and minimum number of units can be observed in the months of April and March respectively. The reason behind that variation can be expressed as holidays and increase in environmental temperature.



Figure 3: Solar power export to grid in 2017

Figure 4 and 5 show the electricity unit demand variation in 2016 and 2017.

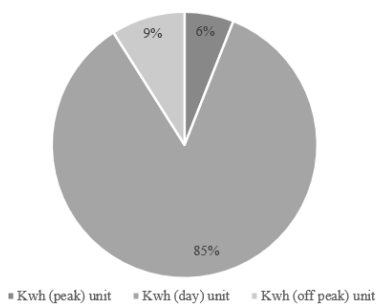

Figure 4: Electricity unit demand variation in 2016

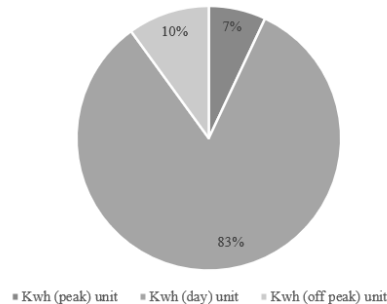

Figure 5: Electricity unit demand variation in 2017

The real power demand is divided into peak, off peak and day demands as for the Sri Lankan tariff system. Thus, each of these have different cost structure based on time of day. It was identified that day time power unit consumptions are 85% and 83% in 2016 and 2017 respectively. There isn't any huge difference between those two years.

It was identified as 02 years ago when academic studies are done in the engineering building an average amount of Rs.4.9 lacks rupees utility bill was monthly paid and when the academic is closed, nearly Rs.1.5 lacks monthly usage was charged. The main reason is the water pumps air conditioners are

working when the academic is closed. The air conditioner consumption is around 60% of total consumption.

There are 293 solar panel in the existing system. Another problem that was identified when discussing with maintenance engineer was the current solar panel cannot be changed, because it was imported from Australia and the initial, installation cost was high. Therefore, it was assumed as not to design a new design for solar panel. The only change which can be done for it is setting a stepper motor to the axis to rotate to get more radiation from sun. Also the machinery usage in the faculties too are consuming a very huge amount from the overall usage, increasing the complexity of re-design.

**7.4. Cost Effectiveness and Energy Efficiency Measures and Renewable Resources**

According to the measured values consumption in the UCJ building can be analyzed as given in Figure 6.

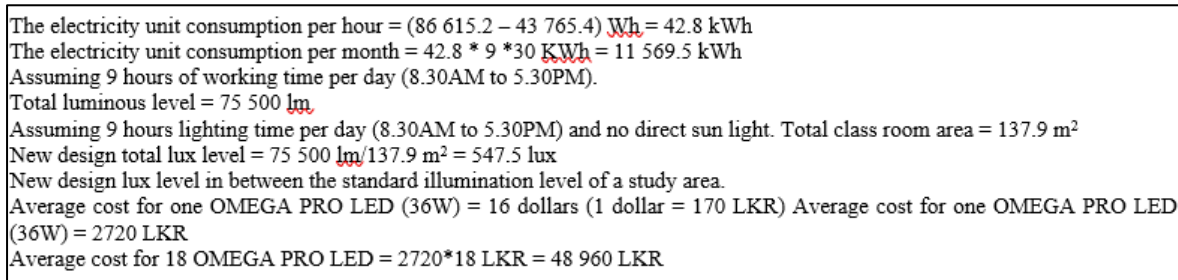

Figure 6: UCJ building consumption

**7.4.1. Corridors Ceiling Recessed**

Corridors ceiling recessed is given in given in Figure 7.

Therefore, simple payback period =  $54\ 400 \text{ LKR} / 7085 \text{ LKR} = 7.67 \text{ years}$

Therefore, main focus is proposing new lighting system is to increase the luminous level inside the partitioned lecture rooms. The second step was to introduce new renewable source. Solar panel has already

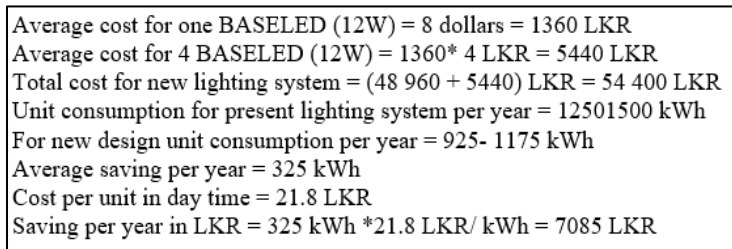

Figure 7: Corridors ceiling recessed

located on the building rooftop. Thus, the calculation of the percentage of saving is given in Figure 8.

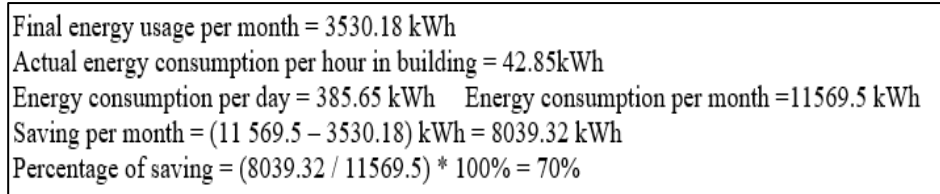

Figure 8: Savings calculation

**7.4.2. Cost Effectiveness of the Energy Efficiency Measures and Renewable Resources**

The cost effectiveness of the energy efficiency is presented in the calculation given in Figure 9.

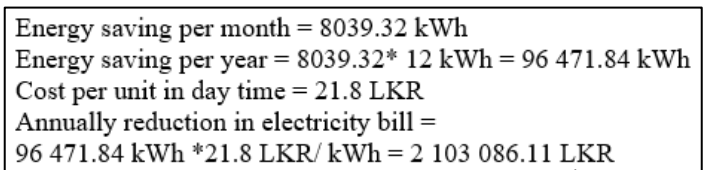

Figure 9: The cost effectiveness of the energy efficiency

**7.4.3. Total Cost for New Lighting System**

The calculation of the total cost for the new lighting system is given in Figure 10.

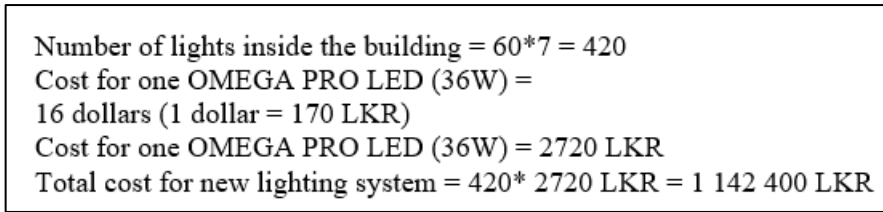

Figure 10: total cost for the new lighting system

**7.4.4. Total Cost for New Energy Efficient Ceiling Fans (ENERGY STAR LP8359\*)**

The total cost for new energy efficient ceiling fans is given in Figure 11.

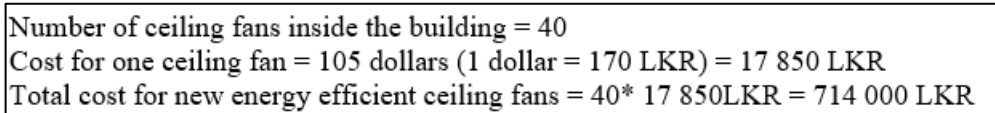

Figure 11: Total cost for new energy efficient ceiling fans

**7.4.5. Total Cost for New Solar Reflective Paint**

The total cost for new solar reflective paint is given in Figure 12.

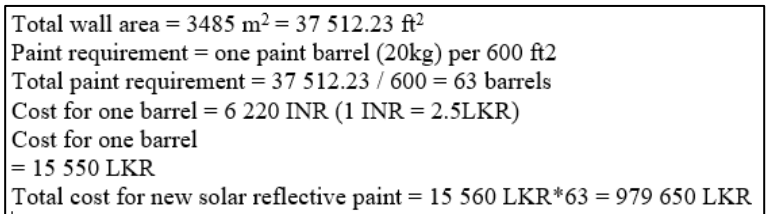

Figure 12: The total cost for new solar reflective paint

**7.4.6. Total Cost for New Rooftop Wind Turbines**

The total cost for new rooftop wind turbines is given in Figure 13.

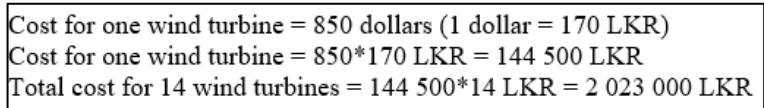

Figure 13: The total cost for new rooftop wind turbines

**7.4.7. Total Cost for Already Installed Solar Panel**

The calculation of the total cost for the already installed solar panel is given in Figure 14.

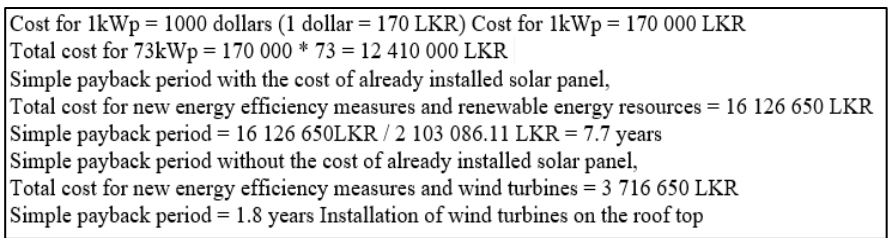

Figure 14: The calculation of total cost for the already installed solar panel

In order to become near net zero energy building there should be total renewable energy resources. Solar panel system was already situated on the engineering building rooftop and it reduces around 45-55% electricity bill.

By installing wind turbines on the building rooftop can also reduce the electricity bill. Calculation of average saving percentage per month from wind turbines is given in Figure 15. Average

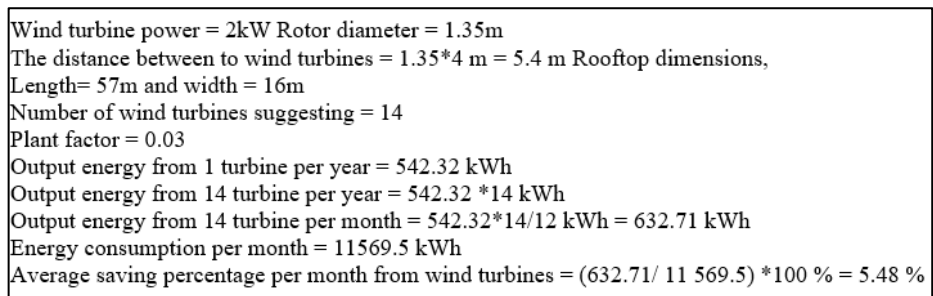

Figure 15

wind speed at the UCJ building rooftop = 4 m/s. Output usable power is depending on the plant factor. That vary with the wind turbine capacity. The maximum plant factor can be achieved by using low-capacity wind turbines. But the output power is less and the initial cost is low. Considering the available space on UCJ building rooftop it's suitable to set 2kW roof mounted wind turbines.

When calculating the number of wind turbines, the gap between two wind turbines should be four times the rotor diameter. Otherwise, it is very difficult to achieve the required power.

#### 7.4.8 Saving percentage from wind turbines

Calculation of average saving percentage per month from wind turbines is given in Figure 16.

The payback period is higher, in this case mainly focus on using the environmentally friendly renewable resources.

Cost for one wind turbine = 850 dollars = $850 \times 180$ LKR = 153 000 LKR
Cost for 14 wind turbines = $153\ 000 \times 14$ LKR = 2 142 000 LKR
Output energy from 14 turbine per year = 7592.52 kWh
Cost per unit in day time = 21.8 LKR
Saving from 14 turbine per year = $7592.52 \times 21.8$ LKR = 165 517 LKR
Simple payback period = Investment / saving = $2\ 142\ 000 \text{ LKR} / 165\ 517 \text{ LKR} = 13$ years

Figure 16: Average saving calculation

## 8. CONCLUSION

Through survey analysis it was identified the current issues with the lighting system of lecture halls that are not meet the required luminous level due to the partitions. By designing a new lighting design luminous levels have been increased inside the lecture halls and decrease in the corridors. Furthermore, LED lamps have less mercury levels compared to fluorescent bulbs thus, movement to such systems can move the building towards sustainability.

By installing wind turbines on the building rooftop can also reduce the electricity bill. Average saving percentage of electricity bill per month from wind turbines is around 5.48%. Furthermore, with some assumptions the simple payback period is around 13 years. The payback period is much higher, in this case mainly focus on using the environmentally friendly renewable resources and to take engineering building to near net zero. When considering the economic aspects of the project output, it is clear that to implement a sustainable energy management system, the implementation cost will be higher. But that can be payback within limited time.

## REFERENCES

- Deng, S., Wang, R.Z. and Dai, Y.J., (2014). How to evaluate performance of net zero energy building—A literature research. *Energy*, 71, pp.1-16.
- Kneifel, J. and Webb, D., (2016). Predicting energy performance of a net-zero energy building: A statistical approach. *Applied energy*, 178, pp.468-483.
- Marszal, A.J., Heiselberg, P., Jensen, R.L. and Nørgaard, J., (2012). On-site or off-site renewable energy supply options? Life cycle cost analysis of a Net Zero Energy Building in Denmark. *Renewable energy*, 44, pp.154-165.
- Thiel, C.L., Champion, N., Landis, A.E., Jones, A.K., Schaefer, L.A. and Bilec, M.M., (2013). A materials life cycle assessment of a net-zero energy building. *Energies*, 6(2), pp.1125-1141.
- Zeiler, W. and Boxem, G., (2013). Net-zero energy building schools. *Renewable Energy*, 49, pp.282-286.
- Zhou, Z., Feng, L., Zhang, S., et al. (2016). The operational performance of “net zero energy building”: A study in China. *Applied energy*, 177, pp.716-728.

# Issues and Challenges of Women in Sri Lankan Construction Industry

Vijayaragunathan Srivishagan\*, Rasanthi Thalpage

Division of Civil Engineering, University College of Matara, Sri Lanka

## ABSTRACT

*The construction industry creates rapid development in Sri Lanka. The Sri Lankan construction industry faces various challenges as skill shortages with technology and managerial with worker magnitude problems. Moreover, the construction industry faced industrial issues as quality, budget and time frame of construction. Women's involvement in several sectors has become a demanding trend internationally but it is mainly in manufacturing, administrative or academic fields rather than the construction field. This research identified the issues and challenges for women entering the construction industry in Sri Lanka to investigate the implementation actions for proper women's involvement in this field. The literature explored several problems for women in construction, such as family commitments, male-dominated culture, gender differences in local industries, lack of female role models, social status about the job, and body nature not supporting the complex construction works. Thus, this research was conducted to develop guidelines to foster female representation in the Sri Lankan construction industry as a solution for several issues the field faces. A Structured questionnaire survey was conducted with hundred professionals, and the descriptive analysis presented the findings with significant implementation actions as media coverage, promotions, flexibility and training.*

**Keywords:** Challenges, Construction Women, Implementation.

## 1. INTRODUCTION

Globally in this 21st century, women have been involved with various fields and replaced for earlier men's dominated occupations in the last two decades. In the 1970s or 1980s most of the eastern countries, women were house-made, and to some extent, women work other industries, but most were in lower positions. At the same time, in western countries, women are enforced in every sector, including the construction industry. But again, in subordinate positions. Nevertheless, a few years ago, women have developed their professional careers. They all desired to work with good social status in medicine, legal procedures' jobs, information management fields, Human resource managerial positions (HR), and various secretaries' occupations. All over the world, women participate for a large part of the labour force. Female participation in the workforce has represented the countries' economic development, educational level and social status (ILO, 2016).

Moreover, it is clearly indicated that the worldwide female workforce percentage has decreased from 52.4 to 49.4 per cent of the total women population, and the men workforce have been reduced from 79.9 to 76.1 per cent. However, women workforce participation is 27 per cent lower than men involvement all over the world. However, construction industry involvement is lower than other industries (Martha, C et al., 2005). Thus, the construction field has not reached an equal workforce, and the women's representation is deficient compared with other areas (CIOB, 2009).

As per BigRentz (2021), when thinking about an industry dominated by men, the first that comes to mind maybe the construction. Women represent only 10.3% of all construction employees and employers. Further, with the low growth of construction projects in 2021 and new construction jobs expected to expand by nearly 2 million in 2022, the industry is looking for recruiting more women than

---

\* Corresponding Author: E-mail - [srivisha87@gmail.com](mailto:srivisha87@gmail.com)

before. The National Association of Women in Construction (NAWIC) has introduced a Women in Construction (WIC) Week in 2021, which is held on March 7-11, 2021 (Jessica Lombardo, 2021). The same author highlights that this WIC Week helps emphasise women's role in the construction industry while raising awareness of opportunities for women in the field. Thus, it is essential to focus on this week in every upcoming year. However, the industry still faces low female careers due to a large part of discrimination that blocks women from entering and staying in the field.

## 2. WOMEN IN CONSTRUCTION, SRI LANKA

According to Powell (2013), the construction industry has contributed the largest (7%) percentage of global economic perspectives. In the Sri Lankan context, employed people are 8,020,445. Moreover, from this working population, 32.90 % (2,619,227) is female and 67.10 % (5,381,218) is male. On the other hand, this employed population has been categorized into three fields as agriculture (26.5%), industries (27.1%) and service sectors (46.4%). Implementation actions have been reducing the barriers of women entering the workforce MFEPS report (2020). According to the ILO (2016), it's important to increase more married women entering the workforce, as most people leave their jobs after marriage. Moreover, it encourages homemakers to enter the workforce, especially in the western province, Sri Lanka. Also, ILO (2016) has recommended the following measures. Those are arranging the work from home, developing the policy and legal procedures for part-time or night work, providing the safety transport system for women, ensuring protection for women from sexual harassment and gender-based issues, and creating better wages and good childcare facilities. Thus, these will motivate the women entering the workforce. Moreover, ILO (2016) revealed that the women workforce percentage has been very low (around 30-35%). It is shocking as especially women were developed with various education and social status during those decades.

The ministry of national policies and economic affairs report (2015) declared a gender deviation in the employments of Sri Lanka. Moreover, the construction industry, while the women representation is around 8,549 of total estimated employees (Department of census and statistics; Ministry of National Policies and Economic Affairs, 2015) as shown in Table 1. On the other hand, there is a lack of research and investigations regarding the gender participation ratio in the construction industry. Construction industry development authority (CIDA, 2015) said that the highest percentage of women participation is 3.37 in non-residential building projects. The minor percentage of 1.78 % is in the utility projects. However, in the residential buildings, 12.99 per cent is female, and 87.01 per cent is male participation of the total employees, which is a huge gap in gender basis. Moreover, overall, women involvement in the construction is 4.52 percentage from the total employees while the male percentage is 95.48. It is also a huge gap in gender analyses.

Table 1: Average Number of Employees and Salaries Classified by Type of Construction- Activity

Type of Construction Activity	Average No. of Employees Male	Average No. of Employees Female	Average No. of Employees Total	Wages & Salaries for Employees (Rs.)
Buildings (Residential)	15,044	2,246	17,290	4,636,664,921
Non-residential Buildings	95,998	3,350	99,348	6,931,412,049
Roads & Railways	15,626	1,236	16,862	4,131,309,964
Utility Projects	19,260	350	19,610	2,454,861,480
Other Civil Engineering Projects	10,553	300	10,853	1,975,421,928

Electrical, Plumbing and Other Construction Installation Activities	6,412	704	7,117	1,788,162,734
Building Completion & Finishing	2,116	51	2,168	229,616,022
Other Construction	15,319	311	15,630	5,102,613,834
<b>Total</b>	<b>180,328</b>	<b>8,549</b>	<b>188,877</b>	<b>27,250,062,932</b>

(Source: Department of Census and Statistics, 2015)

Women entering into the construction are faced with some significant barriers. Those are; Poor attitudes towards women as jokes and comments; Family responsibilities with children and others; lack of female role models, Male domination and receiving less payment by women; male dominated training courses, image of the Industry; Proper work life balance, Clothes with Personal Protective Equipment as helmets and shoes may be unattractive; Lack of same carrier opportunities with gender difference, Career knowledge; culture and working environment; Not getting same recruitment opportunities; Lack of knowledge for women in construction; gender differentiates in local industries; social status about the job and Low information at school age about construction carriers (Vijayaragunathan and Rasanthi, 2019; CIOB, 2009; Amarathunga, Richard and Mukil 2006). Wickramasinghe and Ranatunge (2019) said the majority of the women were dissatisfied in the Quantity Surveying profession in Sri Lanka, as they faced barriers as cultural, social, patriarchal, and lack of facilities provided by the employers. On the other hand, some of the employers are motivating the women entering the construction industry. Also, they have provided necessities to encourage women participation. Figure 1 shows these barriers for women workforce entering into the construction under four main categories.

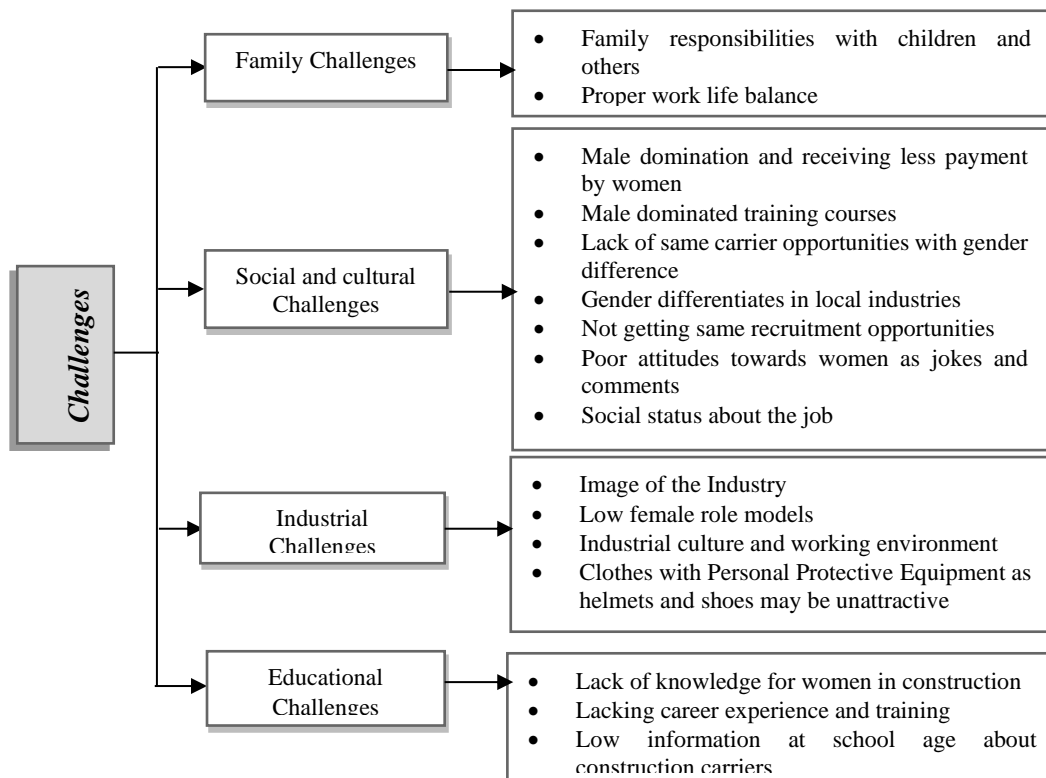

Figure 1: Challenges for women entering into construction industry

(Source: Vijayaragunathan and Rasanthi, 2019; Wickramasinghe, and Ranatunge, 2019; CIOB, 2009; Amarathunga, Richard and Mukil 2006)

### 3. METHODOLOGY

It has used the quantitative technique to identify the mitigation measures of challenges and issues for women entering the local construction industry. The study was conducted based on construction companies in Sri Lanka. Moreover, the sample population of one hundred (100) in the construction field was selected, and structured questionnaires were distributed among those hundred professionals like engineers, quantity surveyors, architects, project managers of both genders. Additionally, this research followed the random sampling method from the construction professional in Sri Lanka, and all the questionnaires were distributed through Google forms. On the other hand, this questionnaire was designed in two stages: the first stage for collecting demographic details about the respondents and the second stage for getting recommendations to implement actions for fostering women's involvement in the local construction industry. Further, the 1st section was prepared as the multiple-choice question and the 2nd section in Likert scale questionnaire format. Finally, the data collected from respondents were descriptively analyzed by SPSS software.

### 4. DATA COLLECTION AND ANALYSIS

This subsection describes how the objectives have been reached through data collection and the data analysis process. This study aims to identify the issues and challenges while investigating the implementation actions of women involved in the Sri Lankan construction industry. The questionnaire survey method was used as the data collection process with structured questionnaires, and they were issued to one hundred (100) local construction professionals. However, only fifty-four (54) respondents fully completed and sent them back, and all the collected data was entered into the analysis purposes.

#### 4.1 Demographic Details

Majority of the respondent population age group 20-30, also experience has been 1-10 years respectively. Moreover, 70 % of respondents from the middle level professionals.

#### 4.2 Research Question

There are various implementation actions identified towards the encouragement of women entering the Sri Lankan construction industry. Those are; Working hours are elastically, Impartiality diversification training, Promote the marketing for existing women in the construction, expand jobs and opportunities to women available, more career information and promotion of the construction industry at a young age, and increasing media coverage which highlights the issues in construction.

Table 2: Data Analysis – Issues and Challenges

Issues and Challenges	Ext. Imp.	Very Imp.	Mod. Imp.	Slight Imp.	Not Imp.
Working hours are elastically	22%	11%	19%	44%	4%
Impartiality diversification training	15%	44%	33%	4%	4%
Promote the marketing for existing women in the construction	52%	15%	4%	19%	11%
Expand jobs and opportunities to women	22%	11%	4%	7%	56%
More career information and promotion of the construction industry at a young age	22%	44%	11%	15%	7%
Increased media coverage highlighting the issues in construction	4%	26%	48%	4%	19%



This questionnaire used as the multiple choice and Likert scale. Moreover, respondents were rate the implementation actions with various ranges of important such as extremely to not important. Future Table 2 shown the results of the surveys, marketing and promotion about existing women in the industry 52 % respondents answered extremely important, and 15 per cent answered as significant implementation actions. Around 67 per cent of people respond as implementation action, so this is the most effective action for encouraging women to be involved in the construction industry. However, the following significant implementation action is more career information and promotion of the construction industry at a young age because 66 per cent respond to it (22 per cent extremely important and 44 per cent very important). Also, equality and diversity training getting 59 per cent (15 per cent significant and 44 per cent very important). In addition, above three implementation actions were more than 50 per cent people answered as extremely and very important. On the other hand, other implementation action is around 30 to 33 % people answered as important such as flexible working hours 33 % (22 % extremely and 11 % important) Expand jobs and opportunities to women 33 % (22 % extremely important and 11 % very important) and increased media coverage highlighting the issues in construction 30 per cent (4 % extremely important and 26 per cent very important). According to the results, there are top three implementation actions for women entering the construction industry: Promote the marketing for existing women in the construction, more career information and advertising of the construction industry at a young age, and equality and diversity training. These results revealed more awareness and mitigated action need for women entering the construction industry in Sri Lanka.

## 5. CONCLUSION

This research found that there is a lack of women representation in the Sri Lankan construction industry, and there are various hurdles for women entering this sector. Moreover, all these hurdles connect with family, social, cultural, educational and industrial barriers. To motivate the women in the construction, they should be provided with relevant ideas early. Future more, women must be trained with appropriate technical programs. In this paper, it's recommended the implementation actions for the women entering into the construction industry, and further, it was identified as the most motivating action among them. Thus, this study revealed that the most encouraging action is increasing the marketing and promotion for women already in construction, also recommended for more career information and promotion of the construction industry at a young age.

In addition, majority (70%) have experienced a situation whilst working in the construction industry where they have felt the women have been treated differently. 90% of participants believe there are more barriers against women entering the construction industry than men. 78% of participants think it is essential to foster women's careers in the Sri Lankan construction industry. Further, participants believe that there is more than 72% gender deviation in the construction industry. Thus, equality and diversity training also motivate the women entering into the construction industries. To support the above approaches, some further actions as flexible working hours and increasing work experience opportunities have to be followed.

## REFERENCES

- Amaratunga, R.D.G., Haigh, R.P., Shanmugam, M., et al. (2006). Construction industry and women: A review of the barriers. In *Proceedings of the 3rd International SCRI Research Symposium*.
- BigRentz. (2021). *Women in Construction: The State of the Industry in 2021*. [Online] Available at: <https://www.bigrentz.com/blog/women-construction> [Accessed 10 April 2021].
- Chartered Institute of Building (CIOB). (2009). *Today's women still trapped by yesterday's attitudes*. [Online] Pp. 36. Available at: <https://www.building.co.uk/todays-women-still-trapped-by-yesterdays-attitudes/3141349.article> [Accessed 15 April 2021].
- Construction industry development authority (2015), *Annual Report*, Available at: <https://www.parliament.lk/uploads/documents/paperspresented/annual-report-construction-industry-development-authority-2015.pdf>.

Department of census and statistics; Ministry of Finance, Economy and Policy Development. MFEPD (2020). *Sri Lanka Labour Force Survey (LFS)*, Available at: [http://www.statistics.gov.lk/Resource/en/LabourForce/Bulletins/LFS\\_Q1\\_Bulletin\\_2020](http://www.statistics.gov.lk/Resource/en/LabourForce/Bulletins/LFS_Q1_Bulletin_2020).

Department of census and statistics; Ministry of National Policies and Economic Affairs. (2015). Survey of construction reports, Available at: [http://www.statistics.gov.lk/industry/SCI\\_Final\\_Report\\_2015.pdf](http://www.statistics.gov.lk/industry/SCI_Final_Report_2015.pdf)

International Labour Organization (2016), *Factors affecting women labour force participation in Sri Lanka*, ILO Cataloguing in Publication, Available at: <[https://www.ilo.org/wcmsp5/groups/public/-/asia/-/ro-bangkok/-/ilo-colombo/documents/publication/wcms\\_551675.pdf](https://www.ilo.org/wcmsp5/groups/public/-/asia/-/ro-bangkok/-/ilo-colombo/documents/publication/wcms_551675.pdf)>.

Jessica Lombardo. (2021). *Take Time to Celebrate Women in Construction*. Available at: <https://www.forconstructionpros.com/asphalt/article/21307405/take-time-to-celebrate-women-in-construction>

Martha, C; Joann V, Francie, L; et al. (2005), *Progress of the World's Women 2005: Women, Work and Poverty*, United Nations Entity for Gender Equality and the Empowerment of Women published, Available at: <<https://www.unwomen.org/en/digital-library/publications/2005/1/progress-of-the-world-s-women-2005-women-work-and-poverty>>

Powell, A., Hassan, T., Dainty, A. and Carter, C., 2007. Strengthening women's participation in construction research in Europe. *Association of Researchers in Construction Management*, pp.347-349.

Sonia Gurjao (2008), *The Changing Role of Women in the Construction Workforce*, CIOB Published, Available at: <https://www.ciob.org/sites/default/files/CIOB%20research%20The%20Changing%20Role%20of%20Women%20in%20the%20Construction%20Workforce.pdf>.

Vijayaragunathan, S. and Rasanthi, T., (2019). An insight to women in construction for fostering female careers in Sri Lankan construction industry. *Journal of International Women's Studies*, 20(3), pp.168-173.

Wickramasinghe, W.M.U, Ranatunge, R.M.U.W (2019). A Study on Gender Inequality in Sri Lankan Construction Industry, study of gender equity in Sri Lanka, PAQS congress, Kuching, Malaysia.

# Online News Consumption Behavior in Sri Lanka

H. A. Gayan Madushanka \*<sup>1</sup>, W.M.S. Sulakshi Rathnayake<sup>2</sup>, Kishan Chaleendra Amarasinghe<sup>3</sup>

<sup>1</sup>Department of Film and Television Production Technology, University of Vocational Technology, Sri Lanka

<sup>2</sup> Ministry of Justice, Sri Lanka

<sup>3</sup>Da Vinci Analytica (Pvt) Ltd, Sri Lanka

## ABSTRACT

*With the expansion of the internet, online news consumption in Sri Lanka has experienced a significant increase. Websites of legacy media outlets as well as online-only sources provide news through their websites as well as other platforms such as social networking sites and mobile apps. The present study investigates the attitudes of online news readers towards news websites in order to determine their preferences for online news sources. Data were acquired through an online survey and in-depth interviews. The results indicate that the majority of online news readers follow social media links to news reports, but continue to rely on established media outlets for news. Websites of popular TV channels were the most preferred news source. News related to society was the most popular news category. The majority of news readers preferred viewing photos and videos to reading news reports. In general, newsreaders demonstrated a tendency for spending less time viewing news, but this depended on the nature of the particular news report.*

**Keywords:** Journalism, Mass Communication, New Media, News, News websites.

## 1. INTRODUCTION

People access information through different sources ('Information Access | Encyclopedia.com', n.d.). Traditional mass media sources such as newspapers and broadcast media were dominant until recently, but their domination is increasingly being challenged with the advent of New Media sources ('Navigating the "infodemic"', n.d.). Since the dawn of the Information Age, the number of media outlets increased simultaneously to the technological developments, which resulted in an increased competition between media outlets. Sri Lankan public is increasingly using New Media to access news (Thuseethan and Vasanthapriyan, 2015). It has resulted in the shift of function of media from print and broadcasting media such as newspapers, television, and radio to internet-based New Media sources of which news websites gain a central position (Bowd, 2016, p.130). The present study will investigate the attitude of newsreaders towards news websites. It is aimed at determining the preference of news readers for news websites and reader behaviors.

## 2. METHODOLOGY

Data acquisition for the study was performed in two approaches; an online survey and in-depth interviews.

### 2.1. Survey

Quantitative data to study the nature and preferences of news readers was gathered through an online survey using a questionnaire which was distributed through Facebook. It obtained basic information on accessing news websites on the internet. Male and female individuals that represent different age groups and different professions participated in the survey. 112 respondents participated in the online survey.

---

\* Corresponding Author: E-mail - [gayan@uovt.ac.lk](mailto:gayan@uovt.ac.lk)

## **2.2. In-Depth Interviews**

In-depth interviews with news readers was aimed at acquiring qualitative data on online news consumption. 12 individuals representing different professions, varying status, and were chosen randomly for the interviews in the following manner:

University students - 02 (public university - 01, private university - 01)

Entrepreneurs - 02 (rural - 01, urban - 01)

Government employees - 02 (male - 01, female - 01)

Private-sector employees - 02 (male - 01, female - 01)

Executive-grade officials in the private sector - 02 (male - 01, female - 01)

Executive-grade officials in the public sector - 02 (male - 01, female - 01)

### **2.2.1. The Profiles of the Interviewees**

P1 - A fourth-year student in Mass Communication at the University of Kelaniya. She is 25 years old, and lives in Negombo.

P2 - A fourth-year student in Software Engineering at the Sri Lanka Institute of Information Technology (SLIIT)

P3 - A graduate of the University of Kelaniya with a bachelor's degree in Public Relations and Media Management. He works as a private tutor in History.

P4 - A bachelor's degree holder in science. He is 27 years old. He has completed an MBA and is currently studying for an LLM. He works as an entrepreneur while pursuing studies at the Sri Lanka Law College.

P5 - A Teacher at the S.W.R.D. Bandaranaike College in Panduwasnuwera. She is 30 years old. She is from Nittambuwa but currently resides in Panduwasnuwera

P6 - A Development Officer at the Exports Development Board. He is 28 years old and is a bachelor. He has done a bachelor's degree and currently, he is following a master's.

P7 - A private-sector employee. She is 30 years old and is a bachelorette. She works as a Telemarketing Executive at Aventurine Ventures (Pvt.) Ltd.

P8 - An employee in the private sector. He is a graduate in arts of the University of Kelaniya. He is 25 years old and is a bachelor.

P9 - An Assistant Manager at Ogilvy. She is 29 years old and is married. She lives in Colombo.

P10 - A 30-year old, executive grade official in the private sector. He works as the Assistant Director of the Nuwara Eliya branch of the SOS Children's Village, a non-governmental organization. He graduated with a bachelor's degree in International Relations from the University of Kelaniya, and has completed an MBA. He currently resides in Nuwara Eliya.

P11 - An Assistant Secretary at the Wayamba Provincial Council. She is an officer in the Sri Lanka Administrative Service (SLAS). She received a bachelor's degree in law from the University of Colombo. She is 30 years old and is married.

P12 - A Senior Lecturer in Mass Communication at the University of Kelaniya. He is 48 years old.

## **3. PREVIOUS RESEARCH**

Preferences in news consumption differs in different areas of the world, according to studies on consumption behaviors of online news readers. Two thirds of the top 25 news websites in the United

States were attached to a news organization on another platform such as television or print (legacy media organizations) according to Olmstead, Mitchell, & Rosenstiel (2011). Their study showed that Google was the primary entry point to even the national newspapers, while Facebook ranked the second or third most important driver of traffic to news websites. Furthermore, the majority of users of news websites in the United States were younger people (Kenny Olmstead et al., 2011). Most of the users preferred text content to online videos. Another important finding was that a considerable amount of traffic was coming from people who directly typed the name of the website or entered a particular website directly to check updates (K Olmstead et al., 2011).

Based on survey data, Nielsen and Schröder (2014) compared the relative significance of social media in news information cycle in eight countries; Denmark, France, Germany, Italy, Japan, Spain, the United Kingdom, and the United States. In all countries, social media ranked behind websites of legacy media organizations and search engines such as Google. In Denmark, Japan, Germany, and the United Kingdom, where legacy media organizations are firmly established, branded-news websites were frequently used than social media sites whereas they were frequently used in Italy, Spain, and France where legacy media organizations do not have a strong presence (Nielsen and Schröder, 2014).

## **4. ANALYSIS**

### **4.1. Point of Entry to Online News**

Websites and Facebook pages operated by media outlets happen to be the primary entry points to online news with almost 60% respondents for each source. 33% respondents each said that they prefer websites and Facebook pages that are operated by other parties (online-only), while 31% said that they use gossip websites to access news.

#### **4.1.1. Gender-Wise Point of Entry to Online News**

A gender-wise depiction of results shows that websites of online-only sources are accessed directly by nearly 60% females and over 50% males. While over 50% male respondents said that they directly access websites of media outlets, less than 15% females followed the same method to access news. Similarly, results related to accessing news websites through Facebook pages of media firms and those that belong to online-only sources also tend to be high (45-52%) for males and low (20% and below) for females.

#### **4.1.2. Occupation-Wise Point of Entry to Online News**

This trend is seen also across different occupations as less than 50% professionals of different fields mentioned that they directly access websites of media outlets. 60% of entrepreneurs and professionals in the 'other' category said that they access news through websites of online-only sources, while over 70% of job seekers 60% of university students, and 50% of the private-sector employees also accessed news websites in the same manner. Over 40% of government employees and entrepreneurs along with nearly 30% of the university students and job seekers followed links on Facebook pages of online-only sources to access news websites.

Out of 12 interviewees, only four mentioned that they access news websites directly to access news, while one person said that he visits news aggregator sites to obtain information. The rest mentioned that their first encounter with a particular news would be through Facebook, a news alert service such as 'Helakuru Esana', or YouTube. Websites operated by media outlets happened to be a confirmatory source for most of them.

These data suggest that most people do not directly access websites of news organizations but use other platforms to obtain information. Part of the traffic to news websites may derive from social networking sites such as Facebook, which underlines the importance of focusing on social media for news dissemination.

## 4.2. News Consumption Habits

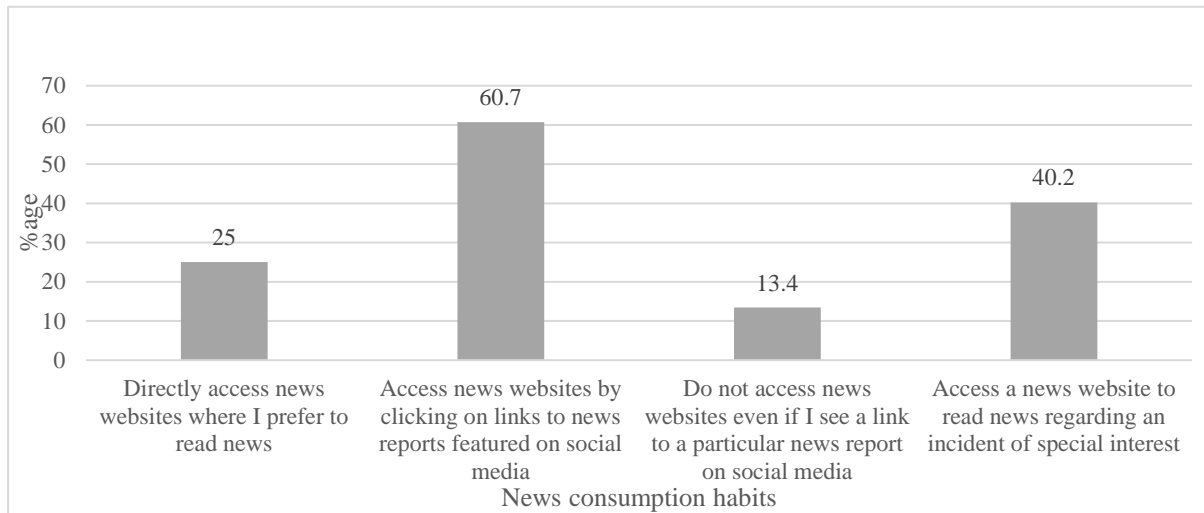

Figure 1: News Consumption Habits

Around 60% of the respondents' access news websites by clicking on links to news reports featured on social media while around 40% access news websites when an incident of special interest occurred. People who directly access websites are comparably low (around 30%), while 15% of the respondents do not follow links to news reports even if they encounter them on social media.

### 4.2.1. Gender-Wise News Consumption Habits

A gender-based chart of news consumption habits further demonstrates that a higher proportion of traffic to news websites is driven through social media than direct access to websites. The percentage of people who directly access news websites stands as slightly above 30% for males and 20% for females whereas 60% of male and female news readers access news websites through links that are featured on social media.

### 4.2.2. Occupation-Wise News Consumption Habits

A similar trend is demonstrated in the chart that focuses on news consumption of different types of professionals in the event of an incident of special interest. All the entrepreneurs and people in the 'other professions' category accessed news websites through links to news reports on social networking sites, while over 50% of employees in the private and government sectors as well as university students and job seekers also accessed news websites in the same manner. In contrast, around 40% of employees in the private sector, university students, and 57% of job seekers accessed news websites directly.

### 4.2.3. Age-Wise News Consumption Habits

In terms of news consumption of different age groups, people in the 46-50 and above 50-year age groups directly accessed news websites, while the same respondents said that they used to visit news websites through links on social networking sites. Over 60% respondents in the 26-30 age group, over 55% of young adults (21-25 years), and 50% of respondents in the 36-40 age group also followed social media links to news websites. In contrast, 57% people in the 31-35 age group, 50% respondents in the 36-40 age group, and around 45% of young adults directly accessed news websites in the event of an incident of special interest.

The interviews reflected that there was an equal tendency towards directly accessing news websites and accessing news reports by following social media links. Some of the interviewees mentioned that they had signed up for news alert services. Only one of them who had installed the mobile apps of media outlets such as CNN, BBC, and Al Jazeera showed a particular interest for foreign news.

### 4.3. Access to News Websites on the Occasion of an Incident of Special Interest

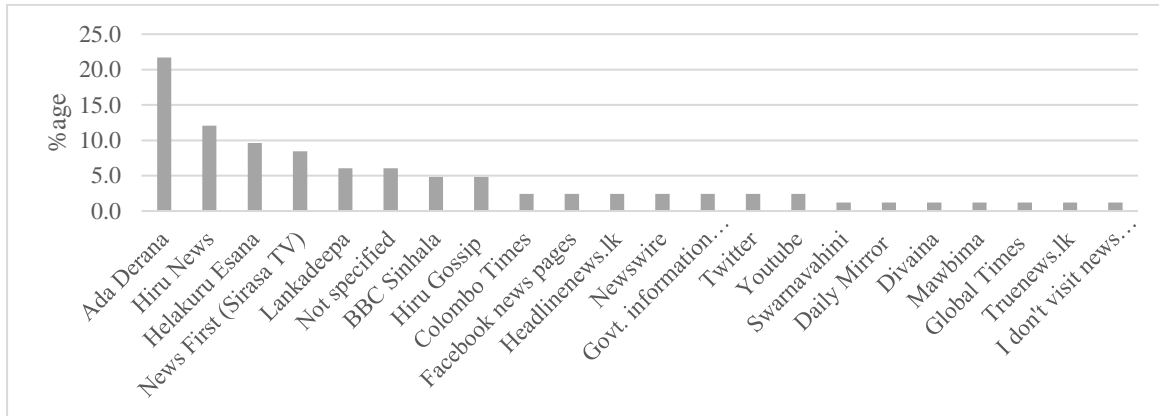

Figure 2: Access to News Websites on the Occasion of an Incident of Special Interest

This question was aimed to obtain information regarding news consumption habits related to incidents of special interest such as bomb explosions and natural disasters. Around 20% of the people use ‘Ada Derana’ website to obtain information when an incident of special interest occurred, while 12% said that they visit the ‘Hiru News’ website on such occasions. Notably, the ‘Helakuru Esana’ mobile app, which received 9.6% of the votes ranked third in the scale while the ‘Lankadeepa’ website ranked fifth with a lesser percentage of votes (6%). It shows a tendency towards mobile apps that can provide news updates faster.

The majority of the interviewees preferred websites of television media outlets as their primary source with regards to incidents of special interest. They opined that those websites were usually updated more frequently than other types of websites. News alerts services operated by media outlets such as ‘TV Derana’ were also an incentive for online news readers to use their websites.

### 4.4. Access to News Websites

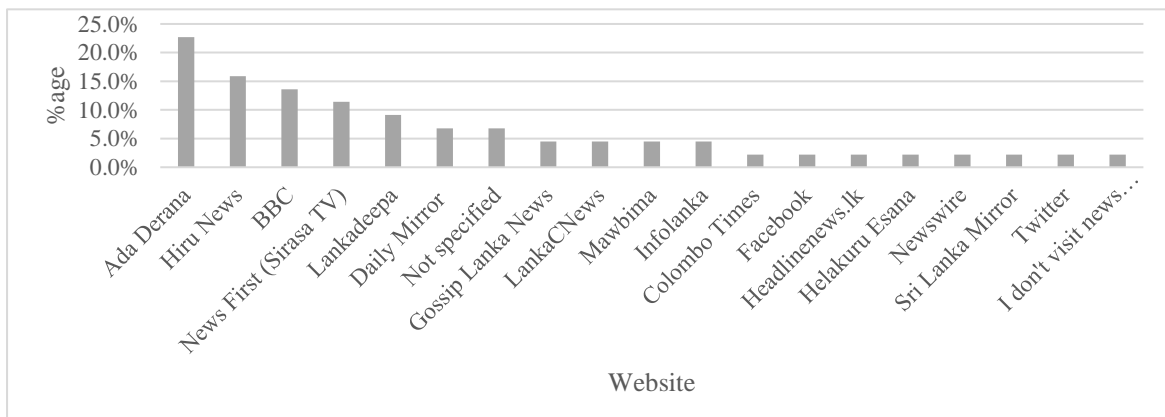

Figure 3: Access to News Websites

This question aimed at enquiring the preference amongst respondents for television and print media outlets as well as news sources which do not function on other platforms. The highest percentage of votes was for ‘Ada Derana’, which accounted for around 22%, while ‘Hiru News’ and BBC ranked second and third with a percentage of 15.9% and 13.6% respectively. News First (Sirasa TV) gained around 11% of the votes, while ‘Lankadeepa’ received 9.1% of the votes. All the other websites received less than 7% of votes.

It was revealed in the interviews that the most preferred type of news websites was that of television media outlets with the ‘Ada Derana’ website being the most preferred amongst them. Some of the

interviewees also preferred the ‘BBC Sinhala’ website whereas social networking sites were also preferred by some of them.

#### 4.5. Purpose of Using News Websites

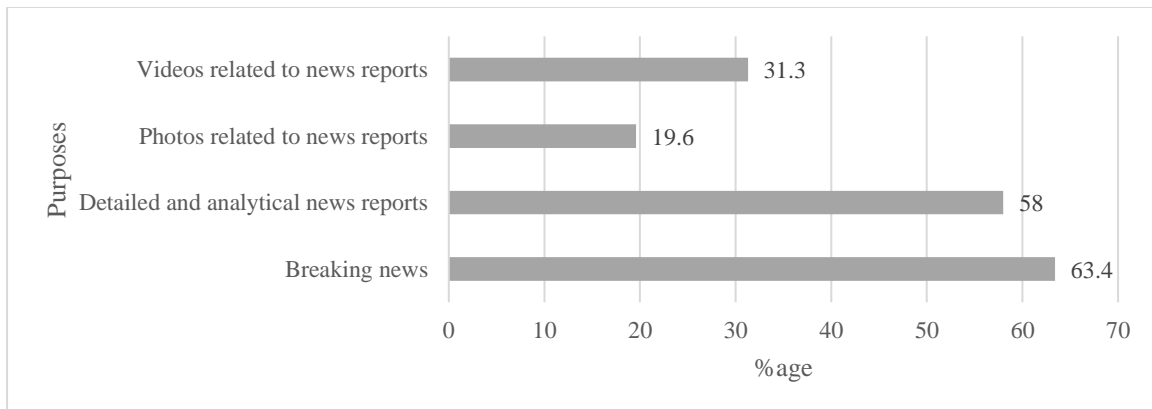

Figure 4: Purpose of Using News Websites

This was a multiple-choice question aimed at obtaining information on the purposes of visits to news websites. ‘Reading breaking news’ was voted by 60% of the respondents as one of their needs, while 58% said that they needed detailed and analytical news reports. Nearly 20% and just above 30% of the responses mentioned that they want photos and videos related to news reports.

The overwhelming majority of the interviewed individuals mentioned that their primary reason for accessing news sources was to read breaking news. Videos and photos related to the reported incidents were also mentioned as a preference. In general access to the latest news was the top priority for the interviewees.

#### 5. CONCLUSION

The survey demonstrated that over 60% of online news readers follow links on social networking sites to access news websites. It also revealed that the majority of news readers shows a tendency to receive news information with less visits to news platforms. The in-depth interviews demonstrated that despite their closeness to lives of people and their speed in news distribution, new media are still considered by many as a secondary news source and that mass media still retain their position as the most reliable primary news source. People encounter news reports on social networking sites, but they prioritize social media pages operated by legacy media (mainstream media outlets) due to their reliability. Another important finding was the significance of mentioning the reporter or the source of information in news reports. In particular, news readers show a low tendency to trust news reports that appear on social media without sources. Photos and videos related news reports on social networking sites are an essential since they increase the reliability of news reports. Most news readers have an inclination for viewing photos and videos related to a particular news, and to spend less time for reading the report. 80% of participants in the survey read news from home. In terms of popularity, news related to society were mentioned by the majority of news readers as their most preferred type of news. News related to politics, economy, and entertainment gained the next spots respectively amongst popular news categories. It was revealed that the highest percentage of survey and in-depth interview participants preferred the websites of ‘Ada Derana’ and ‘Hiru News’. The majority of news readers preferred to view news in a shorter period of time, but it also depended on the nature of a particular news. Nevertheless, the use of new media with the specific goal of accessing news was on a low level.



## REFERENCES

- Anon (n.d.) *Information Access* / *Encyclopedia.com* [online]. Available from: <https://www.encyclopedia.com/computing/news-wires-white-papers-and-books/information-access> (Accessed 16 August 2021).
- Anon (n.d.) *Navigating the 'infodemic': how people in six countries access and rate news and information about coronavirus* [online]. Available from: <https://reutersinstitute.politics.ox.ac.uk/infodemic-how-people-six-countries-access-and-rate-news-and-information-about-coronavirus> (Accessed 16 August 2021).
- Bergström, A. & Jervelycke Belfrage, M. (2018) News in Social Media: Incidental consumption and the role of opinion leaders. *Digital Journalism*. [Online] 6 (5), 583–598.
- Bowd, K. (2016) 'Social media and news media: Building new publics or fragmenting audiences?', in Mary Griffiths & Kim Barbour (eds.) *Making Publics, Making Places*. University of Adelaide Press. pp. 129–144. [online]. Available from: <https://www.jstor.org/stable/10.20851/j.ctt1t304qd.13> (Accessed 16 August 2021).
- Broersma, M. & Eldridge, S. (2019) Journalism and Social Media: Redistribution of Power? *Media and Communication*. [Online] 7193.
- Genzkow, M. & Shapiro, J. M. (n.d.) *Competition and Truth in the Market for News*. 22.
- Harper, R. A. (2010) The Social Media Revolution: Exploring the Impact on Journalism and News Media Organizations. *Inquiries Journal*. 2 (03). [online]. Available from: <http://www.inquiriesjournal.com/articles/202/the-social-media-revolution-exploring-the-impact-on-journalism-and-news-media-organizations> (Accessed 16 August 2021).
- Nielsen, R. K. et al. (n.d.) *Challenges and opportunities for news media and journalism in an increasingly digital, mobile, and social media environment*. 41.
- Nielsen, R. K. & Schrøder, K. C. (2014) The Relative Importance of Social Media for Accessing, Finding, and Engaging with News: An eight-country cross-media comparison. *Digital Journalism*. [Online] 2 (4), 472–489.
- Olmstead, Kenny et al. (2011) *Navigating News Online: Where People Go, How They Get There and What Lures Them Away*. 30.
- Olmstead, K et al. (2011) Navigating news online: where people go, how they get there and what lures them away. Pew Research Center Project for Excellence in Journalism
- Thuseethan, S. & Vasanthapriyan, S. (2015) Social Media as a New Trend in Sri Lankan Digital Journalism: A Surveillance. *Asian Social Science*. [Online] 11.
- Trilling, D. & Schoenbach, K. (2015) Challenging Selective Exposure: Do online news users choose sites that match their interests and preferences? *Digital Journalism*. [Online] 3 (2), 140–157.
- Vermeer, S., Trilling, D., Kruikemeier, S. & Vreese, C. De (2020) Online News User Journeys : The Role of Social Media , News Websites , and Topics Online News User Journeys : The Role of Social Media , News Websites , and Topics. *Digital Journalism*. [Online] 8 (9), 1114–1141.
- Vermeer, S., Trilling, D., Kruikemeier, S. & de Vreese, C. (2020) Online News User Journeys: The Role of Social Media, News Websites, and Topics. *Digital Journalism*. [Online] 8 (9), 1114–1141.
- Young, E. (2015a) *FOR FURTHER INFORMATION ON THIS REPORT*: 40.
- Young, E. (2015b) *How millennials get news: inside the habits of America's first digital generation*. Chicago: American Press Institute.

# Survival Strategies in the New Normal Adopted by Quantity Surveying Firms in the Gulf Region

Chandana Jayalath<sup>1</sup>, Iresha Gamage<sup>\*2</sup>

<sup>1</sup>Department of Quantity Surveying, University of Vocational Technology, Sri Lanka,

<sup>2</sup>Department of Building Economics, University of Moratuwa, Sri Lanka

## ABSTRACT

*Covid 19 created a threat to business survival in the long run. This is no exception to the field of construction and consultancy, including quantity surveying. This phase, on the other hand, can be a turning moment in the emergence of previously unimagined inventive ideas. As the Middle Eastern countries face this crisis, this research focuses on the construction industry with a view to assessing the survival strategies that can be adopted by Quantity surveying firms (QSFs) in the next normal. The study assessed the level of usage of identified survival practices in the delivery of Quantity Surveying services. Using census sampling, 30 senior quantity surveyors representing 30 QSFs in the Gulf region, namely Bahrain, Kuwait, Oman, Qatar, Saudi Arabia, and the United Arab Emirates were sampled. A survey research approach was adopted, and well-structured questionnaires were administered to quantity surveyors from all the registered QSFs. The data was analysed using the mean item score (MIS) and the relative importance index (RII). The study concludes that work from home with reduced timing and reduced salary, decentralized decision making, improved networking, retaining experienced staff in the company, outsourcing and reducing transaction costs are among frequent practices vital for the survival of QSFs in recessionary periods. The study recommends that there is a need for firms to network and collaborate to share resources, which is necessary to survive the fierce conditions of the economy.*

**Keywords:** Covid 19, Gulf Region, Survival strategies, Quantity surveying firms.

## 1. INTRODUCTION

Industries in the Gulf region have been severely affected by the Covid 19 pandemic since its outbreak in March 2020, disrupting the functions of enterprises where the majority of foreign expatriates work (Alsharif, 2020). As the aftermath of the pandemic has pushed for a slow reopening of economies, the unemployment rate in industries, including the construction industry of Gulf countries, still remains high. Alsharif and Malit (2020) contends that a culture of 'wage cuts' among foreign expatriates has become a "norm". Gulf employers have implemented wage cuts ranging from 25% to 50% from which they are confident of reducing their operational expenses in order to secure financial stability in the long run. History is full of similar lessons. These include Korea, Hong Kong and Southeast Asia in 1997-1998, United States of America (USA) in 1974-1975, double-dip recession in 1949 and 1980-1982, Japan in 1993-1994, Thailand in 1997-1998, Australia in 1931-1932, United Kingdom (UK) in 2000 and Venezuela double-dip in 2015-2016 (Chossudorsky, 2010). The recession could not be withstand by almost five out of ten of the Ireland's leading construction companies (Scully, 2012), and similarly, in the UK, there were 2,785 construction company failures in 2008, which increased in the subsequent years (Tansey et al., 2013). The Gulf region is not left out of this current crisis.

Some research carried out in the past has revealed general survival strategies as well as the ones which are specifically applicable to the construction industry. As per the observations of Bakar et al. (2011), construction industry in Malaysia has responded with different survival strategies in both normal and crisis periods. This finding is significant, but assessing the survival strategies adopted by Quantity Surveying Firms (QSFs) offering consultancy services is also important because these organizations represent a sizeable proportion of the built environment. Their survival is, therefore, essential if the

---

\* Corresponding author: E mail - [ireshag@uom.lk](mailto:ireshag@uom.lk)

industry is to continue to be relevant in the development efforts of these countries. Studies carried out regarding survival strategies with respect to the business continuity and recovery of QSFs in Gulf countries are less, hence it is vital to find out what kind of decisions these entrepreneurs make for business survival. This paper includes an extensive literature review to identify likely survival strategies in a crisis, a brief description of the research approach used to obtain primary data in order to achieve the research aim, and a fruitful discussion of the research findings to arrive at conclusions and recommendations of the study.

## 2. LITERATURE REVIEW

The literature on business survival or performance is quite limited (Abubakar, 2020). Scholars were more concerned about the survival of businesses through inventions and innovation. For example, Cefis and Marsili (2019), Ortiz-Villajos and Sotoca (2018) and Wojan et al. (2019) highlight that research has focused more on business continuity achieved through innovation and inventions. Direct disaster assistance, on the other hand, substantially contributes to surviving a business during a crisis (Haynes et al., 2019). In a related development, Casillas et al. (2019) discovered a link between retrenchment strategies and family involvement in business survival. Quite often, flexible HR strategies have been recommended (Abed, 2021). Other common survival strategies include increasing product diversification, entering new markets, and learning new things (Alves et al., 2020). Governments should help the industry survive by lowering interest rates, easing credit terms, and lowering tax payments (Olufemi, 2020). The survival of small businesses heavily depends on technology adoption, especially during the Covid-19 pandemic (Abed, 2021). The 5P marketing strategy (containing key marketing elements such as Product, Price, Promotion, Place, and People) and outsourcing would be optimal solutions for survival and recovery (Aburumman, 2020). Firms practice defensive as well as offensive HR practices (e.g. increasing economic capital, increasing diffused power and accountability, and increasing social capital) during the pandemic to overcome the crisis situation and then adapt to change in order to develop organizational resilience (Brown et al., 2018). Second, these practices have to go beyond routine procedures during a crisis like Covid-19 because adaptive strategies are a must in order to survive, recover from negative effects and ultimately build organizational resilience (Brown et al., 2021).

Technology driven solutions such as Internet of Things (IoT), distant operations run through virtual reality and communication channels with enhanced effectiveness enable social business creation which ultimately reduces operational costs. The current challenging business climate can effectively be assisted by big data and predictive and visual analytics when taking complicated business decisions (Akpan et al., 2021). The Covid 19 has caused a decreasing trend in corporate performance, which may be reversed with strategic agility and AI-enabled competencies. Business operations should be redefined with the assistance of artificial intelligence to yield benefits of improved performance offered at the lowest cost due to its ability to deliver accurate data quickly for effective decision making (Ehiorobo, 2020). Moreover, the decision making process has to be integrated with agility in operations and strategies to overcome the negative effects of this particular global pandemic. Redesigning the market approach is one way to recover from a declining business. For their customers, businesses have introduced more discounts and compliments. Another option to resurrect the business is to provide updates on business applications via social media platforms and portals. It is also a good way to make new market strategies for working remotely with an online presence and digital solutions (Al-Fadly, 2020). Virtual business channels offer a unique chance to re-energize the search for product–market fit and new business models that can survive and thrive in a COVID-19-affected world.

An existing customer base has to be retained via communicating effectively, enhancing customer relationships and ultimately building trust (Liguori and Pittz, 2020). To deal with adversity, entrepreneurs should establish a positive mindset that includes optimism, perseverance, and efficacy. To discover and grab opportunities which arise due to the crisis, growth-oriented SMEs might employ competitive mindsets such as flexibility, speed, and creativity (Purnomo et al., 2021). More informed and decentralized decision-making is enabled in resilient businesses. During and after a crisis,

successful firms use Internet and Communication Technology (ICT) to develop trust and ties with employees, stakeholders, and consumers by integrating intranet, social media, and online communication platforms into their everyday business routines (Obrenovic et al., 2020). Diversification of expertise is also vital during an economic recession (Bakar et al., 2011). Moreover, businesses which diversify into more varieties become less vulnerable to uncertainty. Mac-Barango (2017) also noted that observers in the industry have attributed the diversification of services to structural changes in the construction sector; technological organizational as well as the dynamics of socio-economic and political factors (Ogbu, 2018). Hence, related diversification is an effective strategy that can be practiced by companies engaged in the construction industry to bring down the negative economic impact. Guided by resource-based theory and the relational view, Crick and Crick (2020) examined how the concept of coopetition could be utilized to cope with the Covid 19. Retailers exchanging stock information, pharmaceutical companies collaborating to produce a vaccine, technology mega corporations cooperating for the greater good, and charities forging partnerships for a common purpose are just a few examples.

Survival practices adopted by quantity surveying firms, according to Githaiga (2005), are mainly based around diversification that has to target businesses available in management, evaluation and accounting of projects, contract management, dispute resolution and property valuation with effective utilisation of technological innovations in the construction industry. Ajanlekoko (2002) asserted that professionals must come together, collaborate and cooperate to produce a healthy industry that can champion, nourish and sustain the built environment. Developing interpersonal relationships and a philosophy of human interaction through synergy were described as essential ingredients, which are to be achieved through an upgrade of skills, constant professional education, and development. Adegbembo et al. (2020) find in one of the few recent studies that enhanced service delivery, increased networking, effective knowledge management, and retaining experienced staff are among the numerous practices required for QSF sustainability in recession.

### **3. RESEARCH METHODOLOGY**

To achieve the aim of this research, which is to identify and assess the strategies to be adopted by the QSFs in the new normal, a quantitative approach was used. Thirty (30) registered QSFs in the Gulf region, including 6 countries, namely Bahrain, Kuwait, Oman, Qatar, Saudi Arabia and the United Arab Emirates were sampled. Five (5) QSFs representing each country were sampled. The choice of QSFs was based on the RICS registration. RICS stands for Royal Institution of Chartered Surveyors and a firm is eligible to register for regulation by RICS if the firm provides surveying services to the public and at least 25% of the firm's principals are RICS members. This establishes the rationality behind the sample choice, thus avoiding collecting general background information about the respondents (personal characteristics, profession, qualifications, year of experience, etc.) that would have otherwise been acquired before embarking on statistical analysis. It will also establish the results' credibility. A well-structured questionnaire was used to obtain relevant information to which individual respondents gave their opinions by ticking the appropriate box. Each question in the questionnaire (administered via a short zoom meeting) was designed to measure the extent of adopting each survival strategy initially identified in the literature survey. The analysis of the collected data was performed using the Mean Item Score (MIS) and Relative Importance Index (RII).

### **4. RESEARCH FINDINGS AND DISCUSSION**

The foregoing analysis suggests that most of these firms had experienced various survival strategies in order to remain in practice in the new normal (Table 1). Therefore, they are most likely to give true and credible information.

Companies have adopted remote work policies with the use of the internet and various digital platforms such as Zoom, for example. According to this argument, significant disparities in the labour market have been exposed due to the COVID-19 pandemic (Butterick and Charlwood, 2021). Working from home has been seen as the immediately available strategy in all businesses, including consultancies

whose workloads are exchanged and delivered on computers. Long-standing agreements to lower working time as a substitute for unemployment reduced the number of layoffs and guaranteed that a relatively less number of employees who could not perform by working from home lost their jobs (Adams-Prassl et al., 2020). QSFs have resorted to working from home arrangements since the prevalence of Covid 19 in March 2020, thus it ranked as the top strategy to adopt while having 0.87 of RII value. Decentralized decision making ranked second among the strategies of survival practices and this is in line with Obrenovic et al. (2020) who stated that businesses which are resilient in a dynamic environment, are flexible and decentralized in terms of their organizational culture, while maintaining a dispersed division of labour, allowing for better informed decision-making at all levels of the organization. Decentralization's advantages in the fight against COVID-19 can be observed, for example, in the collection of data and a better understanding of the virus's nature (Naudé, 2020).

Table 1: Survival Strategies Currently in Practice

Ref	Survival Strategies	MIS	RII	Ranking
1.	Work from home with reduced timing/salary	3.83	0.87	1
2.	Decentralized decision making	3.76	0.86	2
3.	Improved networking	3.73	0.86	2
4.	Retaining experienced staff in the company	3.72	0.77	3
5.	Outsourcing	3.70	0.75	4
6.	Reducing transaction and abortive costs	3.67	0.73	5
7.	Reduction of company overheads	3.64	0.69	6
8.	Virtual technology usage	3.57	0.65	7
9.	Improved service delivery	3.52	0.64	8
10.	Improving organizational structure	3.43	0.64	8
11.	Use of social media platforms	3.25	0.63	9
12.	Adoption of innovative ideas	3.10	0.62	10
13.	Going after work in new areas	3.09	0.62	10
14.	Obtaining concessions on loan and tax	3.08	0.61	11
15.	Workforce training and retraining	3.08	0.60	12
16.	Diversifying into areas of competence	3.07	0.59	13
17.	Mergers, acquisitions, and joint ventures	2.96	0.56	14
18.	Staff layoff/downsizing	2.91	0.55	15
19.	Reduction of service charges	2.89	0.54	16
20.	Discounts and compliments for customers	2.76	0.53	17
21.	Effective management of knowledge	2.76	0.53	17
22.	Family involvement	2.50	0.49	18
23.	Coopetition	2.46	0.43	19

Improved networking has a 0.86 RII value and is found to be equally important with decentralized decision making. Firms using business networks and dynamic capabilities operate efficiently and remain resilient in turbulent times. Managing for well experienced employee retention has been found to be next in line with 0.77 of RII value. This is taking purposeful steps to get the maximum out of the experienced employees by encouraging them to continue with the firm and contribute fully to its success. Employee turnover rate and related costs can be minimized by having a successful employee retention program, so that critical personnel would stay for long with the organisation. All of these factors play a role in an organization's long-term survival plan and overall performance. Keeping a good employee is always less expensive than finding, training, and positioning a new one of the same calibre.

QSF are moving towards outsourcing as a strategy to reduce COVID-19 related risk which develops a higher level of agility and resilience for businesses and ultimately, makes it another significant survival

strategy. This is apparently because of the fact that the majority of the quantity surveyors working in the Gulf region are expatriates, so that these employees, once repatriated, can work for the same company on a different reduced remuneration package compatible with their local fee scales. This has helped with a considerable reduction in the burden of regular payments on foreign scales. On the other hand, reducing transaction costs has been identified as the next significant survival strategy. When a good or service is transferred across a technologically separated interface, it is called a transaction (Williamson, 1985). Trade expenses incurred by operations such as producing bid documents, estimating, drafting, and monitoring contracts, as well as abortive costs, are all included in transaction costs in QSFs. Reducing company overheads as far as possible is pretty obvious. Improved decision making and effective organizational management help maintain credibility. According to Margie (2012), globalization, technological advancements, a changing workforce, and changing worker expectations and values create more challenging contexts in which organizations will move slowly, stagnate, and lose their way if good leadership is not provided. Effective organizational management is dependent on the leadership strategy of the firm or business. In agreement with this, Gino and Pisano (2011) concluded that leadership style influences the success of the firm. Improved competition strategy of the firm agrees with Abidin et al. (2014) who state that the choice of a firm's competitive strategy will inevitably lead to the success or perhaps failure of the firm if the strategy chosen is not suitable.

## 5. CONCLUSIONS

The study concludes that work from home with reduced timing/salary, decentralized decision making, improved networking, retaining experienced staff in the company, outsourcing and reducing transaction costs, and company overheads are good survival practices most QSFs are aware of and which these firms use for survival. Furthermore, virtual technology usage, improved service delivery, improving organizational structure, and the use of social media platforms are paramount to keep the QSFs operating. Arguably, all these survival practices have a significant impact on firms and they are not independent. In times of crisis, QSFs have had to adjust to varying environments and client behaviours, as well as identify opportunities. This necessitated a great deal of imagination, invention, and the creation of new business models. However, it is imperative to note that some of these practices have more impact than others. Improved service delivery is a major survival practice that is adopted by QSFs in a recessed economy, and this is because there is a need to build credibility and foster a good relationship between the client and the firm to ensure improved delivery of services. Also, there should be effective and efficient organizational management for the survival of quantity surveying in a recessed economy. This paper implies that, in the event of a pandemic, businesses should concentrate on core skills and capability development strategies in order to survive in the industry.

## REFERENCES

- Abed, S.S., 2021. A literature review exploring the role of technology in business survival during the Covid-19 lockdowns. *International Journal of Organizational Analysis*, 2, 14-25.
- Aburumman, A.A., 2020. COVID-19 impact and survival strategy in business tourism market: the example of the UAE MICE industry. *Humanities and Social Sciences Communications*, 7(1), 1-11.
- Abidin, N.Z., Adros, N.A. and Hassan, H., 2014. Competitive strategy and performance of quantity surveying firms in Malaysia. *Journal of Construction in developing countries*, 19(2), p.15.
- Bakar, A.H.A., Yusof, M.N., Awang, A. and Adamy, A., 2011. Survival strategies of construction companies in Malaysia during two periods of recession, *International Journal of Academic Research*, 3 (4). 481-486.
- Abubakar, A., 2020. Coronavirus (COVID-19): Effect and Survival Strategy for Businesses. *Journal of Economics and Business*, 3(2).
- Adams-Prassl, A., Boneva, T., Golin, M. and Rauh, C., 2020. Inequality in the impact of the coronavirus shock: Evidence from real time surveys. *Journal of Public Economics*, 189, 1– 33.
- Al-Fadly, A., 2020. Impact of COVID-19 on SMEs and employment. *Entrepreneurship and Sustainability Issues*, 8(2), p.629.

- Ajanlekoko, J.O., 2002. National Development and Challenges of Leadership. In *Conference Proceedings of the 20th biennial conference of the Nigerian Institute of Quantity Surveyors*. "Building the blocks of national development. 16-17.
- Alsharif, F.L.A., 2020. Undocumented Migrants in Saudi Arabia: COVID-19 and Amnesty Reforms. Working Paper, King Faisal Research and Islamic Center.
- Alves, J.C., Lok, T.C., Luo, Y. and Hao, W., 2020. Crisis management for small business during the COVID-19 outbreak: Survival, resilience and renewal strategies of firms in Macau, City University of Macau, Research Square.
- Brown, N. A., Orchiston, C., Rovins, J. E., Feldmann-Jensen, S. and Johnston, D., 2018. An integrative framework for investigating disaster resilience within the hotel sector. *Journal of Hospitality and Tourism Management*, 36, 67–75.
- Brown, C.M., Vostok, J., Johnson, H., Burns, M., Gharpure, R., Sami, S., Sabo, R.T., Hall, N., Foreman, A., Schubert, P.L. and Gallagher, G.R., 2021. Outbreak of SARS-CoV-2 infections, including COVID-19 vaccine breakthrough infections, associated with large public gatherings—Barnstable County, Massachusetts, July 2021. *Morbidity and Mortality Weekly Report*, 70(31), p.1059.
- Casillas, J. C., Moreno-Menéndez, A. M., Barbero, J. L. and Clinton, E., 2019. Retrenchment Strategies and family involvement: The role of survival risk. *Family Business Review*, 32(1), 58-75.
- Cefis, E. and Marsili, O., 2019. Good times, bad times: innovation and survival over the business cycle. *Industrial and Corporate Change*, 28(3), 565-587.
- Chossudorsky, M., 2010. *The Global Economic Crisis: The Great Depression of XXI Century*. 1st edition, Montreal Global Research publishers.
- Ehiorobo, O.A., 2020. Strategic Agility and AI-Enabled Resource Capabilities for Business Survival in Post-COVID-19 Global Economy. *International Journal of Information, Business and Management*, 12(4), 201-213.
- Liguori, E.W. and Pittz, T.G., 2020. Strategies for small business: Surviving and thriving in the era of COVID-19. *Journal of the International Council for Small Business*, 1(2), 106-110.
- Alsharif, F. L. A. and Malit, F.T., 2020. Migration and the COVID-19 Pandemic in the Gulf, Regional Programme Gulf States, Policy Report No. 15 – October 2020
- Gino, F. and Pisano, G.P., 2011. Why leaders don't learn from success. *Harvard business review*, 89(4), 68-74.
- Githaiga, F.M., 2005. Quantity surveying practice across African—The Kenyan experience. *Paper presentation: The Third Triennial General Assembly of the Africa Association of Quantity surveyors. New partnership for Africa's development (NEPAD): challenges for built–environment professionals in Africa*.
- Haynes, G. W., Danes, S. M., Schrank, H. L. and Lee, Y., 2019. Survival and success of family-owned small businesses after hurricane Katrina: Impact of disaster assistance and adaptive capacity. *Journal of Contingencies and Crisis Management*, 27(2), 130-144
- Akpan, I.J., Soopramanien, D. and Kwak, D.H., 2020. Cutting-edge technologies for small business and innovation in the era of COVID-19 global health pandemic. *Journal of Small Business & Entrepreneurship*, 1-11.
- Crick, J.M. and Crick, D., 2020. Coopetition and COVID-19: Collaborative business-to-business marketing strategies in a pandemic crisis. *Industrial Marketing Management*, 88, 206-213.
- Mac-Barango, D.O., 2017. The Strategic Imperatives for Sustainable Development of the 21st Century Quantity Surveyors. *World Journal of Innovation and Modern Technology*, 1(7), 54-67.
- Margie, J., 2012. Leadership and organization success. *Avidus associate ltd. Perkin (2003). King Arthur's Round Table*.
- Butterick, M. and Charlwood, A., 2021. HRM and the COVID-19 pandemic: How can we stop making a bad situation worse?. *Human Resource Management Journal*.
- Obrenovic, B., Du, J., Godinic, D., Tsoy, D., Khan, M.A.S. and Jakhongirov, I., 2020. Sustaining enterprise operations and productivity during the COVID-19 pandemic: "Enterprise Effectiveness and Sustainability Model". *Sustainability*, 12(15), p.5981.
- Ogbu, C.P., 2018. Survival practices of indigenous construction firms in Nigeria. *International Journal of Construction Management*, 18(1), 78-91.
- Olufemi, A., 2020. Managing Small Businesses in Nigeria during Covid-19 Crisis: Impact and Survival Strategies. *IOSR Journal of Business and Management (IOSR-JBM)*, 22(8), 24-3.

- Ortiz-Villajos, J.M. and Sotoca, S., 2018. Innovation and business survival: A long-term approach. *Research policy*, 47(8), 1418-1436.
- Purnomo, B.R., Adiguna, R., Widodo, W., Suyatna, H. and Nusantoro, B.P., 2021. Entrepreneurial resilience during the Covid-19 pandemic: navigating survival, continuity and growth. *Journal of Entrepreneurship in Emerging Economies*, 13(4), 497-524.
- Scully, P., 2012. Below cost tendering, *CIF Annual Conference*, Dublin, 12 September.
- Adegbembo, T. F., Ajiferuke, O.O. and Ogbodo, V., 2020. Survival Strategies of Quantity Surveying Firms in Lagos State, Nigeria during Economic Recession. *The Lagos Journal of Environmental Studies*, 10(2).
- Tansey, P., Meng, X. and Cleland, D., 2013. A critical review of response strategies adopted by construction companies during an economic recession, *29th Annual ARCOM Conference*, Association of Researchers in Construction Management, Reading. 679-689.
- Theory Approach for Construction Companies in Malaysia during the Period of Economic Crisis: Survival Strategies. 2nd International Conference on Built Environment in Developing Countries (ICBEDC 2008).
- Williamson, O. E., 1985. *The Economic Institutions of Capitalism*, New York: Free Press.
- Naudé, W., 2020. Entrepreneurial recovery from COVID-19: decentralization, democratization, demand, distribution, and demography, IZA – Institute of Labor Economics, IZA DP No. 13436.
- Wojan, T.R., Crown, D. and Rupasingha, A., 2018. Varieties of innovation and business survival: Does pursuit of incremental or far-ranging innovation make manufacturing establishments more resilient?. *Research Policy*, 47(9), 1801-1810.



## **TECHNOLOGICAL ADVANCES FOR NURTURING EDUCATION**

# Challenges in Using Online Learning Platforms by Undergraduates of the University of Vocational Technology during Early Covid-19 Pandemic Period

R.M.A.C. Rajakaruna\*, Padma Shanthi Y. Gamage

Department of Education and Training, University of Vocational Technology, Sri Lanka

## ABSTRACT

*This study was conducted to identify the frequently used platforms of online learning amid the COVID-19 pandemic period and to find out issues of using online learning platforms amid COVID-19 pandemic period for undergraduates of the University of Vocational Technology. The researcher has used a mixed research method that combined literature review on the research concepts and involved surveys to undergraduates of the Faculty of Education. Fifty-five undergraduates from the Faculty of Education were the sample of this study. Purposive sampling was used to select the respondents. The researcher has used questionnaire for undergraduates. Descriptive statistical techniques were used in this study. Data were analyzed using the Microsoft Excel software package. From the study findings highlighted, the most used online platforms amid early COVID-19 were the ZOOM platform and Google Classroom. Lack of Computer Literacy, Connectivity Issues, Financial Difficulties of Students, Lack of Student Motivation and Shortage of Devices has been identified as issues of using online learning platforms amid the early COVID-19 pandemic period for undergraduates of the University of Vocational Technology. Furthermore, the study provides recommendations on how to take rapid and decisive action in improving the delivery of equitable and quality distance learning opportunities with the support of online learning platforms which will be a great help for the future.*

**Keywords:** Challenges, Covid-19 Pandemic, Online Learning Platforms, Undergraduates.

## 1. INTRODUCTION

### 1.1. Background of the Study

Educational units were struggling to find options to deal with the COVID-19 challenge. Government of Sri Lanka shut down universities nationwide on 13<sup>th</sup> of March 2020. Universities resumed learning from 6 July 2020 by depending on the health guidelines. But it was done on a limited scale, with priority given to final-year students. The resumption also depends on the vice chancellors' decision reflecting the context of each university. Therefore, online education would remain an important means for delivering tertiary education. Several arguments were associated with online learning platforms. Globally, many countries have adopted this online learning approach. Following up on this emergency, Government of Sri Lanka gave instructions through university policymakers to instructing the transfer of lectures by utilizing the internet network. In Sri Lankan Government Universities, learning during pandemic has mostly occurred via online platforms. Teachers sending large volumes of materials to students and conduct the lectures via online learning platforms. To reduce the effects of disrupted learning, higher education institutions utilized existing Moodle-based learning management systems under university web servers. The Lanka Education and Research Network (LEARN) was connected to university web servers and used for online education. The network could monitor the utilization of Zoom daily. In addition, all internet service providers in Sri Lanka provided free access to university web servers during the pandemic until 17 August 2020. In addition to Learning Management System and ZOOM platform, undergraduates in Sri Lanka used many other online learning platforms amid early COVID-19 pandemic period. They are Google Classroom, Google Meet, WhatsApp, etc.

---

\* Corresponding Author: E-mail - [chaminirajakaruna62@gmail.com](mailto:chaminirajakaruna62@gmail.com)

However there are many issues in using online learning platforms for undergraduates. Even though undergraduates had experience of working with computers, learning through online learning platforms without face to face learning approach made some difficulties to them. They need to transform their traditional learning into a fully online learning approach amid early COVID-19 pandemic period. Some undergraduates faced critical situation with lack of computer literacy in this sudden situation. Even though, undergraduates had to work with computers due to this fully only learning approach, everyone doesn't have the same level of knowledge and ability to use computers and related technology. It effects on the learning progress of undergraduates with low computer literacy, amid COVID-19 pandemic period. Online Learning is already having a fair show despite posing challenges for both instructors and students. While instructors need to put in intensive work and time to design the instruction, students need to equip themselves with technical proficiency to decode the course material. Tare common issues faced by students in Online Learning classes and which they need to be solved through proper initiatives for the students' future benefits.

## **1.2. Justification of the Study**

This study can be a good academic source for researchers, especially in Sri Lanka. Uncertainties surrounding the complete eradication of the COVID -19 pandemic and the possible occurrence of future crises, distance education might be here to stay. Therefore, Sri Lanka needs to take rapid and decisive action in improving the delivery of equitable and quality remote learning opportunities with the support of online learning platforms.

There are fifteen universities in Sri Lanka which are established under the authority of University Grants Commission and there are five other government universities established by Acts of Parliament of Sri Lanka. The University of Vocational Technology is Established by the parliamentary Act No. 31 of 2008, and functions under the purview of the Ministry of Higher Education, State Ministry of Skills Development, Vocational Education, Research & Innovations. This study is based on the undergraduates of Faculty of Education (B.Ed. Tech. and B.Ed. ELT) in University of Vocational Technology. This research will be as a trusted academic source and pave the way for scholars, lecturers and students to know the issues of using online learning platform amid early COVID-19 pandemic period for undergraduates in University of Vocational Technology. It will raise the awareness of the people about issues that can be occur relate to online learning platforms which will help to face future crises like COVID-19 pandemic.

## **1.3. Research Questions and Objectives**

### **1.3.1 Research Questions**

This study was guided by the following research questions;

1. What are the frequently used online learning platforms by the undergraduates of University of Vocational Technology during the COVID-19 pandemic?
2. What are the challenges faced by undergraduates when using online learning platforms?

### **1.3.2. Research Objectives**

This study was guided by the following research objectives;

1. To examine the frequently used online learning platforms by the undergraduates of University of Vocational Technology during the COVID-19 pandemic.
2. To find out challenges faced by undergraduates when using online learning platforms.

## 2. LITERATURE REVIEW

### 2.1. Online Learning amid Covid-19 Pandemic

Most of the governments around the world have initiated a common goal to curb the spread of this highly contagious disease by imposing lockdown, social/physical distancing, avoiding face-to-face teaching learning, and restrictions on immigration (Gonzalez et al. 2020). According to data of UNESCO Institute for statistics, at the peak of the pandemic's first wave in mid-April 2020, over 190 countries had implemented nationwide closures, affecting more 90% of the world's student population.(Anwar, Adnan; 2020).

According to the data of a research conducted by Colombo University and ADB (Asian Development Bank) all internet service providers in Sri Lanka provided free internet access to university servers during the corona virus disease (COVID-19) pandemic until 17 August 2020. This has been instrumental in promoting online learning for students in Sri Lanka. Soon after the pandemic was declared in March by the World Health Organization, the Chairman of University Grants Commission (UGC) approached President of Sri Lankan provide free internet access for university web servers, because this is the most practical solution to continue the education of collegiate-level students, taking into account the time, scale, and cost. As a result, UGC and TRCSL reached an agreement with all internet service providers in Sri Lanka to provide free access for university learning management systems and remote learning facilities through the Lanka Education and Research Network (LEARN). To prevent the effects of disrupted learning, higher education institutions utilized existing Moodle-based learning management systems under university web servers. The Lanka Education and Research Network (LEARN) was connected to university web servers and used for online education. The network could monitor the utilization of Zoom daily. In addition, all internet service providers in Sri Lanka provided free access to university web servers during the pandemic until 17 August 2020.

### 2.2 Online Learning Platforms

Ryan (2020) defines an online learning platform is a space or portal filled with educational content and/or live instruction on a particular subject or many different topics. Such platforms - also referred to as "e-learning" - are typically membership-based, but there are other options where users can jump in and learn immediately without registering. An online learning platform is an integrated set of interactive online services that provide trainers, learners, and others involved in education with information, tools and resources to support and enhance education delivery and management.

#### 2.2.1 Zoom Platform

ZOOM platform is a conferencing app which was founded by Eric Yuan in 2011 and launched in 2013. ZOOM platform openly go in for the general awareness during the COVID-19 pandemic while gathering appreciable. According to Yuan, the founder of the platform, ZOOM platform was been perceived 200 million day to day participants throughout May of 2020. The next month, it jumps up to 300 million. Those who joined with ZOOM platform as new users included the UK Cabinet and 90,000 schools in 20 countries. ZOOM was one of the rapidly spreader app of the COVID-19 pandemic with users which growing by 2900 % while having 470000 users as of December 2020. More than 90000 colleges utilized at the peak of pandemic and above 45 billion minutes of webinars were presented by using this platform in 2020 (MansoorIqbal, 2021).

#### 2.2.2 Google Classroom

According to a research which conducted based on business management students at Negeri, Google Classroom is one of the greatest option for teaching learning procedure during covid-19 pandemic to the students and it is easy for students accessed with Google classroom though most students did not use laptops but use smart phones for education purposes. KampusTegalboto&JawaTimmer suggest using Google Classroom continuously during this pandemic due to the belief that this application creates more effective distance learning. Future

source (2020) reveals that Google Classroom recounted around 30 million customers globally after 2014 and recounted more than 100 million users afterward March 2020. According to De Vynck and Bergen (2020), Google is meeting huge victory with Google Classroom application due to convenient, free, and too good than contenders such as Canvas and Edmodo.

## **2.1 Challenges in Using Online Learning Platforms amidst Early COVID-19 Pandemic Period**

### **2.3.1 Lack of Computer Literacy**

Computer literacy is the basic condition for technology learning environment. With the rapid increase in technological development, the need for students and teachers with requisite skills grows. Teachers with rich technology experience and ability in areas such as instructional technology application have helped students in need of advancing computer literacy via technology and using technology as a teaching tool (Jou & Wu, 2012; Anderson & Petch Hogan, 2001).

### **2.3.2 Connectivity Issues**

According to Roger (2020) there are two types of barriers to online learning. They are external and internal barriers. Technical competency attaches with internal barriers while standard of assistance, lack of instructive assistance and technology are attach with external barriers. People from worldwide are meeting technological issues because of the high utilization of online learning systems, video flowing software & additional tools. Online learning platforms are overburden, indigent standard video and audio, internet issues were come out. Internet access is unsteady and the present data schemes are not sufficient to protect the growing e learning requirements. Educators in a tussle to directing the poor internet connections throughout the online lessons (Lisa, 2020). Fasae and Adegbilero-Iwari (2015) identified that the poor connectivity as a major issue that square up to the students.

### **2.3.3 Financial Difficulties of Students**

Fasae and Adegbilero-Iwari (2015) identified that the lofty prices of data subsidies as a major issue that square up to the students. Students who are from impoverished families were the majority of learners who likes to left from distance learning approach and go back to traditional approach of learning. A survey with a sample size of above 1500 parents who are from Parents Together Action revealed that students from law income families that have lower than \$25000 annual income are 10 times shorter are likely to join with remote learning than students who are from families with more than \$100000. Students from impoverished families were also three times more presumably to inconsistent acquire to a device (Salman, 2020).

### **2.3.4 Lack of Student Motivation**

Dornyei (2020) defines motivation as learners' willingness to take part in the language learning process. Motivation is the first condition to take on a learning task and is the engine that powers the process. Muilenburg and Berge (2005) suggested that students' barriers to online learning include time interruptions, lack of motivation to use, infrastructure, perceived skills, technical and social skills. Muilenburg and Berge found that the lack of social interaction, administrative and instructor issues, time and support and learner motivation are the key barriers to online learning.

### **2.3.5 Device Shortage**

Every student and teacher do not have a personal gadget to use for online learning. Many of students and teachers are supposed to share the laptops and computers with their parents, sisters/ brothers to stay on track. In addition to that, there is another issue that everyone faced is a computer crash that usually happens at the most unexpected moment (Lisa, 2020).

### 3. METHODOLOGY

The methodology in this study included a quantitative research methodology that involved survey to undergraduates of Faculty of Education in University of Vocational Technology for the purpose of data collection. The purposive sampling method and convenience sampling technique were used to take the sample in this study. The sample consisted with fifty five undergraduates from both Department of Education and Training and Department of Language Studies. Undergraduates were selected using 1:6 ratios. Primary data was collected from one main source namely; Questionnaire.

Descriptive statistical techniques were used in this study. Data collected were edited, coded, summarized and analyzed using Microsoft Excel software package in conformity with objectives of the study. Descriptive statistics such as frequencies and % were used in the analysis of the demographic and characteristics of respondents.

Table 3.1: Sample

Name of the Degree Program	Sample Size (Batch 1)	Sample Size (Batch 2)
<b>B.Ed. in Technology</b>	Total No. of Undergraduates = 72(1:6) = 12	Total No. of Undergraduates = 68(1:6) = 11
<b>B.Ed. in English Language Teaching</b>	Total No. of Undergraduates = 69(1:6) = 12	Total No. of Undergraduates = 120(1:6) = 20

### 4. FINDINGS

#### 4.1 Frequently Using Online Learning Platforms

##### 4.1.1 Priority of Online Learning Platforms

Undergraduates of Faculty of Education are highly dominated by ZOOM platform and Google Classroom Platforms. The Sample revealed that 40 (41.2%) undergraduates selected ZOOM platform while 29 (29.9%) undergraduates selected Google Classroom as the most used platform amid early COVID-19 pandemic period. In addition to that the sample revealed that 17 (17.5%) undergraduates used WhatsApp, 6 (6.2%) undergraduates used LMS and 5 (5.2%) Undergraduates used Google Meet as the most used online learning platform.

##### 4.1.2. Purpose of Using ZOOM Platform

49 (49.5%) undergraduates used ZOOM with the purpose of Participate to the lectures while 43 (43.4%) undergraduates used it with the purpose of Learning, 5 (5.1%) undergraduates used it with the purpose of Material Sharing and 2 (2.0%) undergraduates used it with the purpose of Submit Assignments.

##### 4.1.3. Purpose of Using Google Classroom

46 (40%) undergraduates used Google Classroom with the purpose of Submit Assignments while 45 (39.1%) undergraduates used it with the purpose of Material Sharing, 21 (18.3%) undergraduates used it with the purpose of Learning and 3 (2.6%) undergraduates used it with the purpose of Participate to the Lectures.

#### 4.2 Challenges in Using Online Learning Platforms

51 (92.7%) undergraduates faced to connectivity issues, 38 (69.1%) undergraduates faced financial difficulties, 37 (69.1%) undergraduates faced Device shortage issues, 31 (56.4%) undergraduates faced lack of computer literacy issues and 30 (54.5%) undergraduates faced lack of student motivation when they were using Online Learning Platforms amid early COVID-1 Pandemic Period.

In addition to that the sample revealed that 19 (34.5%) undergraduates faced issues with time management, 17 (30.9%) undergraduates faced lack of interaction, 15 (27.3%) undergraduates faced Isolation, 10 (18.2%) undergraduates faced Adaptability Struggle and 9 (16.4%) faced Issues with Data Privacy and Security Issues.

#### **4.2.1 Lack of Computer Literacy**

42 (76.4%) undergraduates found difficulties while using ZOOM platform amid early COVID-19 pandemic period due to lack of computer literacy while 13 (23.2%) found no issues with that. The sample revealed that 28 (50.9%) undergraduates found difficulties while using Google Classroom amid early COVID-19 pandemic period due to lack of computer literacy while 27(49.1 %) found no issues with that.

#### **4.2.2. Connectivity Issues**

52 (94.5%) undergraduates found difficulties while using ZOOM platform amid early COVID-19 pandemic period due to unexpected network failure and due to poor network coverage while 3 (5.5%) found no issues with that. The sample revealed that 37 (67.3%) undergraduates found difficulties while using Google Classroom amid early COVID-19 pandemic period due to unexpected network failure while 18 (32.7%) found no issues with that. As same as that 48 (78.2%) undergraduates found difficulties while using Google Classroom amid early COVID-19 pandemic period due to poor mobile network coverage while 12 (21.8%) found no issues with that.

#### **4.2.3 Financial Difficulties of Students**

50 (90.9%) undergraduates agreed that the internet charges for online learning in Sri Lanka amid early COVID-19 pandemic period are expensive while 5 (9.%) didn't agree with that. As same as that the sample revealed that 40 (72.7%) undergraduates found difficulties in obtaining money for internet expenses amid early COVID-19 pandemic period while 15 (27.3%) found no issues with that. The sample revealed that 36 (65.5%) undergraduates failed to used ZOOM platform for learning activities due to inability of get internet fees amid early COVID-19 pandemic period due while 19 (34.5%) found no issues with that. At same as that 24 (43.6%) undergraduates found difficulties while using Google Classroom for learning activities due to inability of get internet fees amid early COVID-19 pandemic period while 31 (56.4%) found no issues with that.

#### **4.5.4. Lack of Student Motivation**

47 (85.5%) undergraduates agreed that looking at phone or computer screen while using ZOOM platform is boring while 8 (14.5%) didn't agree with that. As same as that, 33 (60%) undergraduates agreed that looking at phone or computer screen while using Google Classroom is boring while 22 (40%) didn't agree with that. The sample revealed that 42 (76.4%) undergraduates agreed that looking at phone or computer screen while using ZOOM platform is stressful while 13 (23.6%) didn't agree with that. 30 (54.5%) undergraduates agreed that looking at phone or computer screen while using Google Classroom is stressful while 25 (45.5%) didn't agree with that. 45 (81.8%) undergraduates agreed that ZOOM platform decrease the motivation level to study while 10 (18.2%) didn't agree with that. 37 (67.3%) undergraduates agreed that Google Classroom decrease the motivation level to study while 18 (32.7%) didn't agree with that.

#### **4.5. 5. Device Shortage**

46 (83.6%) undergraduates had personal device or devices to use online learning/ to connect with Google Classroom and ZOOM platform while 9 (16.4%) had not personal device to use for that. And also 7.27% of undergraduates have stated that they had to face technical issues. 5.45% of undergraduates stated that they are using family members' devices. 1.81% of undergraduate stated that he is using neighbors' devices too. 3.63 p% of undergraduates have directly stated that they had financial difficulties to acquire a device for their studies.1.81% of undergraduate stated that learning activities like developing assignments couldn't do with Smart phones.

## 5. CONCLUSIONS AND RECOMMENDATIONS

### 5.1. Conclusions

From the study findings, ZOOM platform and Google Classroom were the frequently used platforms of online learning amid early COVID-19 pandemic period by undergraduates of University of Vocational Technology. The findings of this study show five major issues of using of online learning platforms amid early COVID-19 pandemic period for undergraduates of University of Vocational Technology. They are lack of computer literacy, connectivity issues, financial difficulties of undergraduates, lack of student motivation and device shortage.

### 5.2. Recommendations

Make strong technical infrastructure to provide unrestricted educational services during and after the pandemic. Support undergraduates from low income families to acquire devices and internet connections. Interactive Learning Materials & Strategies. Share recorded lectures for undergraduates who couldn't attend online lectures. Conduct Motivational sessions for undergraduates. Prepare contingency plans to deal with challenges such as pandemics and natural disasters.

## REFERENCES

- Anwar & Adnan, 2020. Online learning amid the COVID-19 pandemic: Students perspectives. *Journal of Pedagogical Research* , pp. 45-51.
- Hayashi, Ryotaro, Garcia, Marito, Maddawin, Angelica, Hewagamage, K. P., 2020. Online Learning in Sri Lanka's Higher Education Institutions during the COVID-19 Pandemic. [Online] Available at: <https://cmb.ac.lk/online-learning-in-sri-lankas-during-the-covid-19-pandemic/>
- Hiruni Jayasena and Wajira Chinthaka, 2020. COVID-19 and developing countries: lessons learnt. *Journal of the Royal Society of Medicine*, pp. 464-465.
- Kattoua, Al-Lozi & Alrowwad, 2016. A Review of Literature on E-Learning Systems in. *International Journal of Business Management and Economic Research*, pp. 754 - 762.
- Kebritchi, Lipschuetz & Santiago, 2017. Issues and Challenges for Teaching Successful Online Courses in Higher Education:. *Journal of Educational Technology Systems*, pp. 4 - 29.
- Lisa Plitnichenko, M. M., n.d. 10-challenges-of-e-learning-during-covid-19. [Online] Available at: <https://jellyfish.tech/>
- M.R. ROSHANA, MUBARAKKALDEEN, A.R.F RIFNA BANU, 2020. Impact of COVID-19 Outbreak on Sri Lanka. [Online] Available at: [https://www.researchgate.net/publication/343587416\\_IMPACT\\_OF\\_COVID-19\\_OUTBREAK\\_ON\\_SRI\\_LANKAN\\_ECONOMY](https://www.researchgate.net/publication/343587416_IMPACT_OF_COVID-19_OUTBREAK_ON_SRI_LANKAN_ECONOMY)
- Mukhopadhyay, A., 2020. How Sri Lanka successfully curtailed the coronavirus pandemic. [Online] Available at: <https://www.dw.com/en/how-sri-lanka-successfully-curtailed-the-coronavirus-pandemic/a-53484299>
- Ryan, 2020. What is an online learning platform?. [Online] Available at: <https://www.idtech.com/blog/what-is-an-online-learning-platform>
- Srinivasan, M., 20120. Sri Lanka sees a sudden spike in COVID-19 cases. [Online] Available at: <https://www.thehindu.com/news/international/sri-lanka-sees-a-sudden-spike-in-covid-19cases/article32776153.ece>
- W. P. T. M. Wickramaarachchi , S. S. N. Perera , S. Jayasinghe3, 2020. COVID-19 Epidemic in Sri Lanka: A Mathematical and Computational Modelling Approach to Control. [Online] Available at: <https://www.hindawi.com/journals/cmmm/2020/4045064/>
- Wargadinata, Wildana and Maimunah, Iffat and Eva, Dewi and Rofiq, Zainur, 2020. Student's responses on learning in the early COVID-19 pandemic. *Journal of Education and Teacher Training*.



# Effectiveness in Online Reading during Covid-19

A.W.K.G. Wijesingha<sup>1</sup>, L.H.D.L.Ranasuriya\*<sup>2</sup>

<sup>1</sup>Department of Education and Training, University of Vocational Technology, Sri Lanka

<sup>2</sup>Department of Language Studies, University of Vocational Technology, Sri Lanka

## ABSTRACT

*Due to the sudden closure of School education during the Covid -19 pandemic, teachers had to use online reading to validate students' knowledge, especially when teaching through online education nevertheless students also had to adapt it as a new learning method. As a result, the transition from traditional classroom-based learning based on book-based reading to online reading caused a shift in teachers' and students' attitudes as well. Thus, this research focused on identifying factors that may cause the effectiveness of online reading. The descriptive research design was used to collect panel data from a sample of students (n=30) and teachers(n=15) in a school in the district of Ratnapura, Sri Lanka, using a convenience sampling technique. Person-based semi-structured interviews were the main instruments of data collection to get an insight into real-life experience. Moreover, a structured questionnaire was employed for the sample. The students and teachers were asked to rate how much they agreed with the statements on a four-point Likert scale, ranging from 'strongly agree' to 'strongly disagree'. Findings attained using data analysis followed descriptively and content analysis. The findings revealed the importance of academics enrolling in online reading and provide insights into how to maintain effective online reading.*

**Keywords:** Covid-19, Digital Reading, Online Reading, Teachers and Students

## 1. INTRODUCTION

According to a study conducted by Motschnig-Pitrik and Holzinger, a teacher is a supporter of students in their search and supply of relevant material, who coordinates the students' presentations of individual milestones of their projects, moderates discussions, consults in all types of problem-solving and seeking solutions, lectures on topics that are selected in plenary discussions with the students and conforms to the curriculum (as cited in (Drexler, 2010)). However, in developing countries, e-learning faces numerous obstacles and challenges and drop-out rates are typically much higher than in traditional, classroom-based teaching (as cited in (Andersson, 2008)). Furthermore, (Anderson, 2008) stated that 'the students in Sri Lanka are not very technologically confident and therefore need much technological support. They are not used to the e-learning culture or distance learning, so many of them expect immediate feedback as in face-to-face classroom teaching.'. This emphasizes the importance of interactivity, presence, and support. According to a study conducted by (Bernard, Fernandez, Hull, & Chaparro, 2003) it is emphasized that young children are now spending an increasing amount of time reading online documents, including being tested online in schools. Therefore, online reading differs from traditional printed reading, the emergence of digital texts has altered the nature of academic reading (Jusoh & Abdullah, 2015). Reading on paper is known as reading in print, whereas reading online, whether on a smartphone, tablet, or computer, is known as reading in digital formats (Loh and Sun, 2018). Furthermore, Jusoh & Abdullah (2015) argue that because research on online reading is still in its infancy, a lot more work needs to be done in order to fully understand what students are doing when searching for information online. This empirical evidence demonstrated the importance of investigating the impact of both teachers' and students' roles in completing online reading successfully.

---

\* Corresponding Author: E-mail - [dilniranasuriya@gmail.com](mailto:dilniranasuriya@gmail.com)

## 1.1. Problem Statement

Many students and teachers in Sri Lanka's school context were more familiar with printed books and handouts distributed freely in a physical classroom environment; however, the current education system, which is shifting to an online classroom, demonstrated a difference for both parties because online education requires extra effort on access to online reading. To encourage children to engage in online reading as a different Teaching and Learning Activity (TLA) in the online classroom, both students' and teachers' learning needs must be addressed in order to maintain the effectiveness of online reading. It was further strengthened by (Priyadarshani and Jesuiya, 2021) Teachers and students play an important role in online lectures because their expectations and attitudes are critical for motivation and learning.

At one point, the researcher observed that some school teachers, including tuition masters, sent printed materials to students' homes directly, while others sent downloadable links to access reading materials, e-books, and presentations for students. Even though online reading is common at the university level, most school children are unfamiliar with online searching, according to the researcher's personal experience. Thus, this present study addresses both drawbacks as well as the effectiveness of online reading. Although information technology is considered as "cool" in Sri Lanka, it is still not regarded as a proper tool for delivering education; it is still regarded as second best and not perceived to be "as good as" traditional face-to-face teaching. If e-learning is not properly promoted and introduced, this could become a major impediment (Andersson, 2008). With this inspiration, the researcher's interest was drawn to study the effectiveness of online reading during COVID-19 pandemic as a purpose of this study and it was obvious that there was a considerable amount of literature on online reading in the international context has been investigated, but not thoroughly in the Sri Lankan educational system.

## 1.2. Research Questions and Objectives

Previous research conducted by (Bui, 2021) at the University of Transport and Communications on the theme of 'Students' attitudes to online reading in the era of technology' divided into three broad objectives such as (1) students' attitudes toward online reading, (2) What influences students' online reading, and (3) how do students read online materials effectively. To comply with the previous study current study was drawn based on these facts, and the assumptions that arise in this context in terms of students and teachers in the Sri Lankan school system context do indeed involve.

### 1.1.1. Research Questions

1. What influences students' and teachers' online reading attitude?
2. What are the difficulties face by teachers and students in online reading?
3. What causes determined by teachers and students on online reading effectiveness?

### 1.1.2. Research Objectives

1. To find out what factors influences students' and teachers' online reading attitude?
2. To find out the difficulties face by teachers' and students in online reading?
3. To find out what causes determined by teacher and student on online reading effectiveness?

## 2. METHODOLOGY

Within the framework of a survey research design, quantitative and qualitative research approaches (Mix method) were used in this study. Thus both quantitative (questionnaires) and qualitative (semi structured interviews) methods were used in the study. The population of this study was the teachers and students who are in secondary schools in Sri Lanka. The target population of this study consists of teachers and students from in the Rathnapura district. Teachers and students who are in secondary

classes at the R/ Nivi/Yainna Vidyalaya Sri Lanka, was selected as a convenient sample for this study. Study done by Brown recommended that 40–60 participants are adequate, with far fewer perhaps actually being needed (as cited in Ha, 2014). Therefore, sample of students (n=30) who are in secondary grades and teachers (n=12) who teaches at secondary classes were selected. In this study (6-9,10-11) junior and senior secondary grades were considered because post- secondary grades were not available in current context. Semi-structured interviews in which questions were prepared to guide the interview towards the fulfillment of research objectives, while additional questions were posed as the interviews progressed. Interviews and questionnaires were conducted in Sinhala and translated into English. A study done by Ionescu (2018) stated that four-point Likert scale as which the respondent is asked how strongly he or she agrees or disagrees with a statement. Four points were used for the Likert scale (strongly agree, tend to agree, tend to disagree and strongly disagree) to eliminate the possibility that the respondent will ‘sit on the fence’ by ticking the middle ‘not sure’ category which will render the response ambiguous. Furthermore, as a reason, the researcher pointed out that the four-point Likert scale was used because the respondents had the ability to express a clear opinion on the statements, which enabled the researcher to clearly determine whether the respondent was more or less a risk-seeker or more or less risk-averse in certain situations. With this inspiration, I adopted 4 points Likert scale as I want specific details in the current situation. The data collected from the questionnaire were descriptively analyzed. As the strength of the data was more focused on qualitative data analysis, quantitative data were not analyzed in depth. Interviews were analyzed using content analysis.

### 3. FINDINGS

Table 1: Students’ Demographic Profile

	Years of study						Level of ICT proficiency		English language proficiency		Sinhala language proficiency		Online reading as a Teaching/ learning tool	
	6	7	8	9	10	11	H	L	H	L	H	L	Expert	Fairly experience
(%)	10	16.7	16.7	30	6.7	20	63.3	36.7	60	40	76.7	23.3	6.7	93.3
(F)	3	5	5	9	2	6								

Student demographic profile is shown in Table 1. In this study, students are divided into grades based on their years of study (grades 6, 7, 8, 9, 10 and 11) and it presented as follows; 10%, 16.7%, 16.7%, 30%, 6.7%, 20% as represented in each grade. The level of ICT proficiency, English language proficiency, and Sinhala language proficiency was then graded as high or low, with 63.3 % indicating high ICT proficiency, 60% indicating high English language proficiency, and 76.7 % indicating high Sinhala language proficiency. Lee and Wu (as cited in Gubbels, Swart and Groen, 2020) demonstrated that the availability of ICT resources and their use at home has a positive impact on reading performance as long as students use ICT resources for online reading-related activities such as reading news, using wikis or online encyclopedias, and participating in online discussion forums. As a result, respondents were asked if they were familiar with online reading as a learning tool. Furthermore, Kulatunga's research indicates that the majority of Sri Lankan students prefer to read relevant academic books (as cited in Rosli et al., 2018). It was clearly emphasized that the teacher's role is valuable as a guide for students toward online reading, and teacher demographics were based on the same questions as shown.

According to the Table 2, teacher demographic factors were divided into years of teaching, and it was discovered that there were 8 (66.7 %) for grade 6, (66.7 %) for grade 7, grade 9 (75 %), grade 10 (66.7 %), and grade 11 (83.3 %). Despite the count of 12 teachers of secondary classes, year of teaching count got higher in number because teachers considered their time table as years of teaching.

Table 1 : Teachers' Demographic Profile

	Years of teaching (%)						Level of ICT proficiency		English language proficiency		Sinhala language proficiency		Online reading as a Teaching tool	
	6	7	8	9	10	11	H	L	H	L	H	L	Expert	Fairly experienced
(%)	66	66	7	7	66.	83.	66.	33.3	75	25	100	0	66.7	33.3
(F)	8	8	9	9	8	10	7							

Further, the level of ICT proficiency among teacher participants can conclude as high (66.7%), English language proficiency (75%), Sinhala language Proficiency high it was 100%. As a teaching tool, online reading scored a 66.7 % expert rating and a 33.3 % fairly experienced rating.

### 3.1. Influential Factors Students' and Teachers' Attitudes toward Online Reading

Table 3 illustrates variety of factors influence teachers' and students' attitudes about online reading

Table 0: Influential factors on online readers' attitude

Statement	Teachers (%)				Students (%)			
	SA	A	D	SD	SA	A	D	SD
<b>I do online reading just for fun.</b>	8.3	66.7	16.7	8.3	3.3	26.7	53.3	16.7
<b>I do online reading just for extra knowledge.</b>	33.3	58.3	8.3	00	10	33.3	50	6.7
<b>When reading online I make sure whether I can download the material and share with others.</b>	41.7	58.3	00	00	3.3	66.7	26.7	3.3
<b>I only go for online reading when only someone recommend it to do</b>	16.7	58.3	25	00	6.7	56.7	30	6.7
<b>I only refer Sinhala medium texts in online reading.</b>	16.7	50	8.3	25	3.3	53.3	36.7	6.7
<b>I prefer go to online reading in English medium because I can improve my English knowledge.</b>	50	41.7	8.3	00	00	63.3	36.7	00
<b>Online reading can use to improve my vocabulary and knowledge in any preferred language</b>	50	50	00	00	6.7	30	56.7	6.7
<b>Online reading allows me to access information at any time and from any location.</b>	25	58.3	16.7	00	00	56.7	43.3	00
<b>Online reading allows me to stay up to date on general knowledge.</b>	33.3	58.3	8.3	00	16.7	56.7	23.3	3.3
<b>My communication skills have improved as a result of my online reading.</b>	41.7	58.3	00	00	10	53.3	36.7	00
<b>I am able to complete quality work because of the availability of online materials.</b>	33.3	50	16.7	00	6.7	56.7	36.7	00

The following statement of student 1 “Online reading කරන්නේ අපි teacher link එකක් දුන්නොත්, කියවලා බලනවා” (“When the teacher provides a link, we can access that information by reading it online”). It is acknowledged that students require the teacher's assistance, and it is obvious that when students become aware of irrelevant text material, they may stop processing information from online reading. Furthermore, a study conducted by (Tseng, 2010) revealed that during online reading, students can access specific information by clicking on a hyperlink. When they click on the various hyperlinks, they are frequently redirected to a different web pages. Furthermore, the majority of teachers emphasized that, to reduce the amount of time spent on irrelevant material, they share online reading materials directly with their students as a hyperlink or pdf.

The difficulties encountered by teachers and students in online reading are depicted in Table 4, which is based on questionnaire responses.

### 3.2 Difficulties Faced by Teachers and Students in Online Reading

Table 2: Difficulties impacted on online reading

Statements	Teachers				Students			
	SA	A	D	SD	SA	A	D	SD
When reading online, I have to translate English in to Sinhala.	25	50	8.3	16.7	3.3	56.7	30	10
I always want hard copy of the online reading text because it was convenient to me.	25	75	00	00	6.7	50	40	3.3
I have less time to go for online reading.	8.3	75	8.3	8.3	10	66.7	23.3	00
When reading online, I want more time.	16.7	75	8.3	00	00	66.7	3.3	00
I have a difficulty of finding what relates with subject matter in order to find what to read online and not to.	00	66.7	33.3	00	3.3	60	36.7	00
I always need someone to simplify online reading in order to understand the online reading texts.	8.3	50	33.3	8.3	10	63.3	26.7	00
I always lose concentration on online reading Because of numerous web pages and information.	25	50	25	00	00	63.3	33.3	3.3
Online reading is not suitable for Sinhala medium as it contain less articles to find.	00	75	8.3	16.7	00	70	30	00
When I continue online reading, I always guess the meanings of some words and phrases.	8.3	83.3	8.3	00	6.7	53.3	36.7	3.3
Access to teaching materials is difficult.	16.7	83.3	00	00	00	66.7	30	3.3
Some circumstances, such as power outages and poor internet connections, make online reading difficult.	25	75	00	00	00	70	23.3	6.7
Low technology makes it difficult to quickly and precisely find information.	16.7	75	8.3	00	6.7	63.3	26.7	3.3
I'm not familiar with academic information websites.	16.7	66.7	8.3	8.3	6.7	70	20	3.3
I'm having difficulty modifying teaching materials.	25	66.7	8.3	00	00	56.7	33.3	10
I feel insecure about how students will receive and comprehend my information through online reading.	25	58.3	16.7	00	3.3	53.3	33.3	10
I don't believe I can obtain high-quality information by online reading.	8.3	83.3	00	8.3	6.7	66.7	20	6.7
I don't have proper ICT resources to use in online reading.	16.7	66.7	16.7	00	00	76.7	16.7	6.7

During the interview, both students and teachers expressed dissatisfaction with the overall process, citing difficulties such as power outages and spotty internet connections while online reading, as well as the lack of immediate feedback and technical support and the absence of collaboration with others as in a traditional classroom setting was mentioned. It was further strengthened by the following teacher response;

Teacher1: “ගොඩක් ළමයින්ට අපි වැඩ දුන්නත් ඒවා කරන්න භරියන device එකක්, internet එහෙම නෑ. ගොඩක් අය අම්මලා තාත්තලා එනකන් ඉන්නවා,තවත් අයට ආර්ථික අපහසුතා තියෙනවා. English වගේ විෂයන් teach කරනකොට අපි කිව්වත් මේ දේවල් online read කරන්න කියලා ඒ වට උදවු කරන්න දෙමාපියන්ට දැනුම මදි, ළමයි උනන්දුවෙනවත් මදි, උනන්දු කරනවත් මදි ” (“We give instructions and guidelines for online reading but some students don't have devices, others are waiting for their parents to come, and still, others are struggling financially. When we teach subjects like English, even we give materials to children but some parents can't encourage students and some have no interest.”)

Some students and teachers acknowledged that they had drawbacks to online reading during the interview session. Some admitted to having difficulty watching on screen, which was not as convenient as book handling because they had difficulty taking notes and highlighting points, whereas others believed that online reading was inconvenient for both students and teachers due to eyesight problems that they encountered while reading on screen.

### 3.3. Determinants of Online Reading Effectiveness

Table 5: Perception of the effectiveness of online reading

Statement	Teachers				Students			
	SA	A	D	SD	SA	A	D	SD
When reading online, I prefer to translate English text into Sinhala in as little time as possible.	8.3	66.7	16.7	8.3	3.3	30	63.3	3.3
I want to take notes while reading online.	8.3	75	16.7	00	00	56.7	36.7	6.7
I only prefer to go Sinhala texts in online reading	8.3	58.3	33.3	00	00	73.3	23.3	3.3

I want a guidance to distinguish what relates to curricular to know what to read online and what not to.	16.7	50	33.3	00	10	56.7	30	3.3
I prefer when online reading have no difficult words or phrases to understand.	16.7	58.3	25	00	13.3	66.7	20	00
I prefer online reading because it allows me to focus on the most important points.	16.7	75	8.3	00	3.3	70	20	6.7
I prefer online reading because it contains more colorful text and images.	16.7	75	8.3	00	6.7	66.7	23.3	3.3
I prefer if there is any financial aids for online reading	16.7	75	8.3	00	10	53.3	33.3	3.3
I would prefer if there was a way to prompt online reading awareness, such as seminars.	8.3	91.7	00	00	3.3	56.7	40	00
I would prefer if there is a suitable ICT resources for online reading.	16.7	75	8.3	00	3.3	66.7	30	00

The following response addressed the suggestions that were made by both students and teachers to make the online reading effectiveness. Teacher 3: “ඕන කෙනෙක්ම ඕන දෙයක් අද පලකරන්න පුළුවන්නේ internet එකේ ඉතින් නිවැරදිව ළමයින්ට Subjects වලට අදාල තොරතුරු,එකම තැනකින් teachers ලට ළමයින්ට ගන්න තැනක් තියෙනවනම් හොඳයි සියලු ශ්‍රේණිවලට feedback එකක් දෙන්න, අදහස් හුවමාරු කරගන්න වගේ ඔය සහයෝගීතාව උනන්දුව වැඩි කරන්න ක්‍රමයක් තියෙනවනම් හොඳයි online reading කරනවානම්”. (“ Anyone can post anything on the internet nowadays, so it would be nice if there was a place for teachers to get the right information for their students at all grades can access online reading as a place where both students and teachers can communicate, get feedback, and improve collaboration and excitement.”).

#### 4. CONCLUSIONS

The study's findings revealed that the most influential factors are student and teacher attitudes toward online reading. It emphasized the importance of student-teacher collaboration as well as technical support, and the teacher was aware that the student needed assistance to begin online reading in both school and home settings. Questionnaire responses in the study regarding the students' and teachers' attitudes toward online reading demonstrated the awareness about the possibilities that can be obtained through online reading, such as accessing information at any time and from any location, staying up to date on general knowledge, improved communication skills, improving vocabulary and knowledge, and so on. Furthermore, the researcher examined the difficulties that both teachers and students have faced in online reading. It was clear from the interviews that the majority of teachers concluded that students lack proper ICT resources, Internet facilities, financial aids and students' parents provide no motivation to students, and parents lack the knowledge to involve their students in online reading activities when they were studying at home. During the interview session, students identified some difficulties, such as poor internet connection, power outages, a lack of proper ICT resources, a desire for hard copy due to unfamiliarity, loss of concentration, difficulty reading English texts and converting them to Sinhala, ignorance of academic searching websites, and a lack of feedback support and guidance. Finally, the researcher solicited feedback from both students and teachers regarding the effectiveness of online reading through interviews and questionnaires. The questionnaire revealed that most of the participants wish for a way to prompt online reading awareness such as seminars, ICT resources, guidance and financial aids and internet facilities. Teachers and students who participated in the interview session expressed a desire for more online reading and if there is a location where teachers and students can access the right information for any school grade level, communicate, receive feedback, and improve collaboration and excitement. Research done by (Lim, H. J., Bong, M., & Woo, Y., 2015) emphasized that Parental reading support, as well as teachers' reading instruction and assignment strategies, predicted students' use of learning strategies, and it can be concluded that it is an important in online reading attitude of students. Moreover, this study has found that some people are lacking attitude on online reading by pointing reasons like it was far different and inconvenient than traditional book based reading. These reasons include difficult handling, difficulty of taking notes and highlighting points, and eye sight problems mainly. The current study identifies a number of factors that can assist education partners in successfully initiating online reading among students and teachers, and this study primarily focuses on motivating education partners to take appropriate action to overcome the difficulties they are currently facing. According to the findings of a study conducted by (Loh and Sun, 2018), adolescents prefer print but shift toward more online reading as they get older; thus, educators must consider both

print resources and technology when considering how to support adolescent reading engagement. Educators can also consider asking students what kinds of devices they would like to read on and investing in devices. For the current situation, as a researcher, I come up with a suggestion to prompt user's online reading engagement by using blogging and kindle as an effective method, taking into account the problems that have arisen in the current situation.

## REFERENCES

- Andersson, A., 2008. Seven major challenges for e-learning in developing countries: Case study eBIT, Sri Lanka. *International journal of education and development using ICT*, 4(3), pp.45-62.
- Bernard, M.L. et al., 2003. The effects of line length on children and adults' perceived and actual online reading performance. *Proceedings of the Human Factors and Ergonomics Society Annual Meeting*, 47(11), pp.1375–1379.
- Bui, T. N. (2021). Students' Attitudes to Online Reading in the Era of Technology at the University of Transport and Communications. *Asia CALL Online Journal*, 12(3), pp. 1-8.
- Drexler, W., 2010. The networked student model for construction of personal learning environments: Balancing teacher control and student autonomy. *Australasian journal of educational technology*, 26(3).
- Gubbels, J., Swart, N.M. & Groen, M.A., 2020. Everything in Moderation: ICT and reading performance of Dutch 15-year-olds. *Large-scale Assessments in Education*, 8(1).
- Ionescu, O., 2018. Risk behaviour and the financial auditor—A study of gender differences.
- Jusoh, Z. and Abdullah, L., 2015. Online Survey of Reading Strategies (OSORS): Students' Online Reading in Academic Context. *Malaysian Journal of Distance Education*, 17(2).
- Lim, H.J., Bong, M. and Woo, Y., 2015. Reading attitude as a mediator between contextual factors and reading behavior. *Teachers College Record*, 117(1), pp.1-36.
- Loh, C. and Sun, B., 2018. “I'd Still Prefer to Read the Hard Copy”: Adolescents' Print and Digital Reading Habits. *Journal of Adolescent & Adult Literacy*, 62(6), pp.663-672.
- Priyadarshani, H.D.C. and Jesuiya, D., 2021. Teacher's Perception on Online Teaching Method during COVID-19: With Reference to School Level Teachers at Faculty of Education, the Open University of Sri Lanka. *Shanlax International Journal of Education*, 9(2), pp.132-140.
- Rosli, N.A., Razali, N.F., Zamil, Z.U.A., Noor, S.N.F.M. and Baharuddin, M.F., 2017. The determination of reading habits among students: A concept. *International Journal of Academic Research in Business and Social Sciences*, 7(12), pp.791-798.
- Tseng, M.C., 2010. Factors that influence online reading: An investigation into EFL students' perceptions. *Reading*, 10(1).

# Experiences in Online Learning during Covid-19 Pandemic in a College of Technology in Sri Lanka

M. Pirashanthan\*

Sri Lanka College of Technology, Colombo -10, Sri Lanka

## ABSTRACT

*The world is currently experiencing a challenging environment as a result of the Covid 19 pandemic. This has led to various challenges in education, with the sudden closure of educational institutions in Sri Lanka, forcing the need to move learning and teaching activities towards alternative arrangements, causing the need to implement online learning and teaching activities. This study is modeled on Sri Lanka College of Technology students to understand technological advances and challenges. The data required for the study were provided to Sri Lanka College of technology students through Google forms, and responses were received from 296 students. The primary data SPSS recorded and analyzed using descriptive and inferential analysis. The results of the study identified online learning as technological advances to save time and money, improve knowledge of technology and information technology, easy to submit assessments and watch recorded videos, and mainly the exchange of knowledge as challenges and network related issues, learning practical lessons, technical issues, share online tools with family members, identify challenges encountered during their learning and teaching activities. Appropriate institutions should take steps to further improve the positive attitude among students regarding technological advances in online learning and rectify problems related to online learning.*

**Keywords:** Covid-19, Learning challenges, Online learning, Technological advances, Tertiary Vocational Education.

## 1. INTRODUCTION

Corona virus spread worldwide and was declared as a global pandemic by World Health Organization (WHO) in 2019. The Covid-19 pandemic is the world's greatest serious health concern in the last century. The world's present situation is grave in this scenario since no one understands how the virus is transmitted or how it can be halted (Currie et al., 2020, p 83). Technical education and training institutions programs and business activities were closed to control the spread of Covid 19 due to this pandemic, government, community groups, and educational institutions came under severe pressure. Therefore, to adapt distance and online to ensure the continuity and upscaling of skill development while keeping communities safe for blended Tertiary Vocational Education and Training (TVET) in response to Covid-19 (Commonwealth of learning 2020, p1). The unexpected Global health crisis has called for a change in many areas, including education. This crisis has resulted in a dramatic movement away from conventional classroom learning models, training, and evaluation in a large number of educational institutions, including TVET providers. (International labor Office 2021, p 17 a). The emergence of such a complex situation in Sri Lanka has pushed the traditional classroom system towards alternative arrangements. During the Covid-19 pandemic, the Sri Lankan government also introduced online and distant learning technology as a new standard for TVET instructors and students (Hayashi.R et al, 2021 p2).

Sri Lanka is a middle-income country, and we, the students, the instructors and institutions have to face various problems related to online learning and teaching processes. Common issues related to online learning and teaching have comprised a lack of general and technological infrastructure, effective user-friendly distance learning platform, Staff capacity to facilitate distance learning through the provision of high-quality pedagogical tools, budgetary constraints, practical skill training, and apprenticeship

---

\* Corresponding Author: E-mail- [mpirashanthan1975@gmail.com](mailto:mpirashanthan1975@gmail.com)



delivery. (International Labour Office, 2021, p 46 b). To its relatively low theoretical component and increased practical skills, the TVET courses are faced with more problems than the courses offered by other higher education institutions. This study focuses on student-related issues only.

Covid-19 has had many positive effects as well as adverse effects. Online learning incorporates digital literacy skills, providing lifelong learning skills and skills desired by employers such as self-direction, self-efficiency, and reducing written work time and cost for students. The Covid-19 outbreak sparked unprecedented attempts to ensure learning continuity and hastened the adoption of innovative approaches. (World Bank Report, 2021, p.22). This study aims to identify technological advances and challenges of online learning-based students of the College of Technology Sri Lanka during the Covid-19 pandemic.

## **2. OBJECTIVES**

- i. To identify experiences in online learning based on College of Technology Sri Lanka students during a Covid-19 pandemic.
- ii. To identify challenges of online learning based on the students of College of Technology Sri Lanka during the Covid-19 pandemic.

## **3. PROBLEM STATEMENT**

Sri Lanka is a developing country that already faces many challenges in the Education sector. Many problems were encountered in switching on to the online education system from the conventional due to the Covid-19 pandemic. It is feared that considerable dropouts in technical education and training, which is one of the popular alternatives for students who are unable to access the University education system, will cause a wide gap in the education sector and the job market. Among the students who have registered for their courses at Maradana College of Technology in 2021, only about 35% (Management Information Unit, Department of Technical Education and Training confirmed this by email, on 20th August 2021.) are participating in online learning. Others seem to have either abandoned their courses or been disinterested in the change to online learning. Even the numbers who are following the online courses at present do not seem stable. This situation could lead to an acute shortage in the numbers of skilled labor in the future. It would also pave the way for a series of problems such as unemployment, skill shortage, underemployment and poverty. In the above circumstances, it becomes imperative to increase the numbers involved in online learning, it is a viable alternative to conventional education, particularly given the current pandemic crisis, and sustain the process.

## **4. LITERATURE REVIEW**

Here are the results of studies conducted in Sri Lanka and other countries regarding online teaching and learning.

Online education is not given much importance. It is considered as an alternative arrangement faced with various challenges in online education one is faced with problems in online delivery of the practical test. In Online exams, the students, teachers do not have adequate knowledge of online teaching system-related infrastructure, and it needs to be improved further. Traditional higher education is also under challenge, and the government must regulate it. (Ramez. et al., 2021, p 347)

Online classes are seen as an alternative to the traditional classroom. Teachers face a variety of issues related to online classes. Appropriate steps should be taken by the relevant authorities to resolve the problems of teachers concerning the technological and network-related aspects. The government should facilitate proper training for students and teachers. Teachers are with a positive attitude towards online classes. Sri Lanka has achieved some progressive goals in comparative online teaching. Relatively, rural students face more problems. (Priyadarshani & Jesuiya, 2021, p 138).

Based on TVET research, online teaching is more complex than the curriculum used in laboratories. Satisfaction with the online system is found to be 67.5 %. New teaching approaches are needed for

practical courses rather than theoretical courses. Problems related to network users are more prevalent in rural areas, and the government should provide relatively more facilities.

Most of the studies are related to online teaching in school education and online teaching of university students. There is a dearth of research in the field of Technical Education on online learning and teaching. This is identified as the research gap.

## 5. METHODOLOGY

The study compiled a population of around 900 students enrolled in the Sri Lanka College of Technology and currently pursuing diploma and certificate courses in online classes. The students were given a separate Google forms questionnaire for each course of study through the WhatsApp groups they interact with to obtain the required data. This questionnaire for students consists of two main sections; the first section consists of demographic variables. The second section has the first six questions on technological advances and the following questions about online learning challenges. Secondary data were also obtained through the Department of Technical Education and Training (DTET) reports, research papers, and websites. The questionnaire responses of 296 students were received and analyzed based on five Likert scales and data analyzed SPSS statistics software package. A descriptive and inferential approach has been used to analyze these quantitative data.

## 6. RESULT AND FINDINGS

### 6.1 Validation of Reliability

Cronbach's Alpha reliability testing is performed to determine an instrument's and its items' internal consistency (see Table 1). The alpha value is typically believed to be more than 0.6. The reliability test is conducted in following this study by a section including the sections A and B set of questionnaires.

Table 1: The reliability test for student's perception of online learning technological advances

	<b>Corrected Item- Total Correlation</b>	<b>Cronbach's Alpha if Item Deleted</b>	<b>Cronbach's Alpha</b>	<b>Number of Items</b>
<b>Online Classroom Saves Time and Money</b>	.536	.747	<b>0.781</b>	6
<b>Online Classrooms Improve My Technology and information technology (IT) Knowledge</b>	.567	.738		
<b>Can submit assessments submissions easily and quickly and watch recorded video</b>	.509	.753		
<b>Online Learning Stimulates Innovation and Creativity ideas</b>	.594	.731		
<b>Learning and Exchange of Knowledge takes place mainly in online Classrooms</b>	.493	.756		
<b>Online classrooms are more efficient than traditional classrooms</b>	.477	.761		

According to Table 1, the reliability test indicates that the items are suitable and may be regarded as an instrument for the responders. However, the researcher might take this into account and improvise the items to increase the alpha value and hence the instrument's reliability. According to Table 1, dependability indicates that the alpha value is more than 0.6, indicating that the items had good and adequate reliability and were approved as research instruments by respondents.

Table 2: The reliability test for students' perception of online learning technological advances and challenges.

	<b>Corrected Item- Total Correlation</b>	<b>Cronbach's Alpha if Item Deleted</b>	<b>Cronbach's Alpha</b>	<b>Number of Items</b>
<b>I oppose the network-related problem when I join an Online classroom</b>	.468	.480	<b>0.608</b>	4
<b>I face problems when learning practical lessons</b>	.343	.572		
<b>I encounter technical issues when joining an Online classroom</b>	.546	.424		
<b>I share online tools with my family members</b>	.239	.659		

As shown in Table 2, the reliability test indicates that the items are appropriate and may be deemed an instrument for the responders with an alpha value greater than 0.6. However, the researcher can take this into consideration and improvise the items to raise the alpha value and therefore the instrument's reliability.

## 6.2 Demographic Background of Students

Table 3: Demographic background of respondents

<b>Factors</b>		<b>Frequency</b>	<b>percentage (%)</b>	<b>Factors</b>		<b>Frequency</b>	<b>percentage (%)</b>
<b>Gender</b>	Male	164	55.4	<b>Software</b>	Zoom	111	37.5
	Female	132	44.6		Google meet	96	32.4
<b>Course</b>	Theoretically based	207	69.9	Google classroom	18	6.1	
	Practical based	89	30.1	WhatsApp	71	24	
<b>District</b>	Colombo	102	34.5	<b>Spending time</b>	0 - 2	50	16.9
	Gampaha	146	49.3		0-4	91	30.7
	Kalutara	48	16.2		4 - 6	46	15.5
<b>Curriculum pursuing</b>	Certificate	176	59.5		6 - 8	14	4.7
	Diploma	120	40.5		8 - 10	9	3
<b>Family income</b>	Less than 25,000	152	51.4	More than 10	86	29.1	
	25000- 49000	114	38.5	<b>Internet Service Provider</b>	Mobitel	46	15.5
	50000-74000	25	8.4		Dialog	142	48
	75,000 - 99000	1	3		Hutch	40	13.5
	100000-124000	2	7		Airtel	37	12.5
Over 125000	2	7	SLT fiber		8	2.7	
<b>Cost of Internet connection (per month)</b>	500	64	21.6	Others	23	7.8	
	500- 999	128	43.2	<b>Join family Members to the Online Class</b>	1	132	44.6
	1000- 1500	70	23.6		2	96	32.4
	Over 1500	32	11.1		3	43	14.5
<b>Device</b>	Smart phone	257	86.8		4	17	5.7

<b>Living Area</b>	Laptop	32	10.8	<b>Type of Internet connection</b>	5	4	1.4
	Desktop	6	2		Above 5	4	1.4
	Others	1	0.3		Advance payment	241	81.4
	City	133	44.9		Postpaid	55	18.6
	Village	163	55.1				

According to gender, there are 164 male respondents (55.4%) in the overall population (n=296), compared to just 132 male respondents (44.6%). With a total of 207 (69.9 %) respondents from the overall population depending on course, theoretically based respondents have the highest frequency, followed by practical based respondents with 89. (30.1 %). Gampaha district has the highest proportion of responders with 146 (49.3 %), followed by Colombo district with 102 (34.5 %) and Kalutara district with 48. (16.2 %). According to the general population, the most common curriculum pursued is a certificate with 176 (59.5 %) responders, followed by a diploma with 120. (40.5 %).

From the overall population, most of the family income is less than 25000. Most of the respondents spend 500 – 999 on the Internet connection. The highest number of respondents have used smartphones in their learning process. Most of the respondents live in the village. Most of the respondents are learning in the zoom app. 2- 4 hours they are learning weekly. 86 respondents are studying more than 10 hours per week. Most of the respondents are used dialog internet service providers. Primarily, one person joint in online learning in all families. Two hundred and forty-one respondents are making their payment by the advanced payment and 55 respondents make their payment by postpaid.

### 6.3 Students' Perception on Online Learning Technological Advances

From the data in Table 4 on students' perceptions of technological advances in online learning. The mean value of the first, second, and fifth statements about online learning technological advances is more than three. So, we can conclude they are getting some technological advances from online learning (Time and money, Technology and information technology (IT) Knowledge, submissions easily and quickly and watch recorded video and Exchange of Knowledge). The other two statements (4 and 6) mean values are 2.81 and 2.53.

Table 4: Student's perception of online learning technological advances

No	Items	Strongly disagree	Disagree	Neutral	Agree	Strongly agree	Mean	Standard Deviation
1	Online Classroom Saves Time and Money	15 (5.1%)	37 (12.5%)	175 (59.1%)	62 (20.9%)	7 (2.4%)	3.0 3	0.796
2	Online Classrooms Improve My Technology and information technology (IT) Knowledge	13 (4.4%)	28 (9.5%)	132 (44.6%)	103 (34.8%)	20 (6.8%)	3.3	0.895
3	Can submit assessments submissions easily and quickly and watch recorded video	11 (3.7%)	27 (9.1%)	96 (32.4%)	139 (47%)	23 (7.8%)	3.4 6	0.901
4	Online Learning Stimulates Innovation and Creativity ideas	19 (6.4%)	89 (30.1%)	122 (41.2%)	60 (20.3%)	6 (2%)	2.8 1	0.900

5	Learning and Exchange of Knowledge takes place mostly in online Classrooms	11 (3.7%)	55 (18.6%)	140 (47.3%)	81 (27.4%)	9 (3%)	3.0 7	0.852
6	Online classrooms are more efficient than traditional classrooms	42 (14.2%)	98 (33.1%)	118 (39.9%)	32 (10.8%)	6 (2%)	2.5 3	0.935

#### 6.4 Students' Perceptions on Online Learning Challenges

According to the data in Table 5 on students' perceptions of online learning challenges. All the statements on online learning technological challenges perception of students mean value is higher than 3. So, we can conclude they are getting some technological challenges from online learning (Network issues, Face problems when learning practical lessons and online tools not, enough).

Table 5: Student's perception of online learning challenges

No	Items	Strongly disagree	Disagree	Neutral	Agree	Strongly agree	Mean	Standard Deviation
1	I oppose the network-related problem when I join an Online classroom	7 (2.4%)	9 (3%)	77 (26%)	140 (47.3%)	63 (21.3%)	3.82	0.882
2	I face problems when learning practical lessons	9 (3%)	11 (3.7%)	59 (19.9%)	133 (44.9%)	84 (28.4%)	3.92	0.950
3	I encounter technical issues when joining an Online classroom	6 (2%)	12 (4.1%)	87 (29.4%)	139 (47%)	52 (17.6%)	3.74	0.865
4	I share online tools with my family members	10 (3.4%)	60 (20.3%)	51 (17.2%)	144 (48.6%)	31 (10.5%)	3.43	1.032

## 7. CONCLUSIONS

The online teaching method being implemented due to the Covid19 pandemic shows a positive impact on technological advances. This study has identified technological advances such as online classes saving time and money, improving technology and information technology knowledge, making assessment submission easily and quickly and watching recorded videos. Learning and exchanging expertise occur primarily in online classes and have a positive attitude towards traditional classroom activity. The content was found to be the results of the study.

Network related problems, problems in learning practical lessons, technical issues and sharing online tools with family members, have been identified as challenges. The study found that online learning tools do not pose significant obstacles to family circumstances. Although online learning does not facilitate confirmation of whether or not the specific skills have been attained and possible skill shortage in the future, it does contribute to the development of and adaptability to the new technological transformation. Plans to improve students' attitudes towards online learning should be implemented in the future, and relevant educational institutions should take steps to mitigate these problems related to this.

## REFERENCES

Commonwealth of Learning (COL) (2020). Strategies for Blended TVET in Response to COVID-19. [http://oasis.col.org/bitstream/handle/11599/3624/2020\\_COLStrategies\\_for\\_blended\\_TVET\\_COVID19.pdf?sequence=1&isAllowed](http://oasis.col.org/bitstream/handle/11599/3624/2020_COLStrategies_for_blended_TVET_COVID19.pdf?sequence=1&isAllowed)

- COVID-19 Impact on Technical and Vocational Education and Training in Sri Lanka. ADB Briefs, 168, 1-8.
- Currie, C.S., Fowler, J.W., Kotiadis, K., Monks, T., Onggo, B.S., Robertson, D.A. and Tako, A.A., (2020). How simulation modelling can help reduce the impact of COVID-19. *Journal of Simulation*, pp.1-15
- Hilma Eriliana, et al., 2021. Vocational students' perception of online learning during the vivid 19 pandemic., 27. DOI: <https://doi.org/10.21831/jptk.v27i1.34283>[Accessed 26 August 2021].
- International Labour office 2021. Skills development in the time of COVID-19: Taking stock of the initial responses in technical and vocational education and training. Ilo.org. 2021. [online] Available at: [https://www.ilo.org/wcmsp5/groups/public/---ed\\_emp/---ifp\\_skills/documents/publication/wcms\\_766557.pdf](https://www.ilo.org/wcmsp5/groups/public/---ed_emp/---ifp_skills/documents/publication/wcms_766557.pdf)> [Accessed 26 August 2021].
- Management Information Unit, Department of Technical Education Department, (2021). E-Mail to Director, College of Technology, Colombo10, August2021.
- Priyadarshani, H.D. & Jesuiya, D., 2021. Teacher's perception on online teaching method during COVID-19: With reference to school level teachers AT Faculty of education, the Open University of Sri Lanka. *Shanlax International Journal of Education*, 9(2), pp.132–140.
- Rameez, A., Fowsar, M.A. & Lumna, N., 2020. Impact of Covid-19 on higher education sectors in Sri Lanka: A study based on South Eastern University of Sri Lanka. *Journal of Educational and Social Research*, 10(6), p.341.
- The World Bank, 2021. skills development in the time of Covid-19. [online] Geneva, Switzerland: International LabourOffice, p.67. Available at: <[\(http://\(Skills development in the time of Covid-19, 2021\)\)](http://(Skills development in the time of Covid-19, 2021))> [Accessed 26 August 2021].

# Online Course Delivery during Covid -19 Pandemic in Sri Lankan Universities: Students' Perspectives

T. K. Malwatta<sup>\*1</sup>, L.W.S. Kularatne<sup>2</sup>

<sup>1</sup>Department of Software Technology, University of Vocational Technology, Sri Lanka

<sup>2</sup>Department of Language Studies, University of Vocational Technology, Sri Lanka

## ABSTRACT

*One major challenge for the higher education sectors around the world at present is the Covid -19 pandemic. Expanding the ability to adapt to the immediate demands of online courses has become a necessity. The main focus of this online survey was on learners' perceptions of altered learning experiences. The sample included 60 students from five universities in Sri Lanka. A structured questionnaire was used to collect data. It showed that COVID-19 pandemic has caused learning disruptions, difficulties in social interaction, physical and mental health problems, and an economic crisis. One of the positive aspects of online learning was that it saves time without being needed to go to university. Other positive results included faster completion of the program, which could later be learned from the course recording. This crisis has been unveiled as an opportunity for universities to improve the use of digital tools to improve the quality of teaching and learning. It is recommended that this regime be supported by investment in digital infrastructure to improve e-learning in the higher education sector in Sri Lanka.*

**Keywords:** Covid19 Pandemic, Digital Tools, Higher Education, Immediate Demands, Online Learning.

## 1. INTRODUCTION

The rapid development of technology has led to the need to update educational services and select new course options, such as online learning. Students should study whenever and wherever they can get to (Wolfinger, 2016). The everyday life has been threatened by the unprecedented eruption and spread of COVID-19 as a global pandemic posing serious challenges. In the situation of the pandemic, interest has increased in studying the various possibilities of digital learning (Rapanta, et al., 2020).

Senior educators have been forced to select digital platforms in course delivery as a result of the immediate impact of the epidemic with no other option to face the demands (Kernohan, 2020) Most of the universities inevitably adapted changes to the design and delivery of courses. Undergoing disturbances of social life and economic calamity. In order to remain competitive in an upcoming service market and adapt to uncertainty and new challenges with changing circumstances, academics acting as leading providers of higher education have not discontinued all of their programs, although some activities, such as visits to national and international sites and some forms of assessment, have been suspended or adapted. It has also been reported that, for many scientists, forced immersion in technological learning has become a disorienting and unusual experience shaped by panic and coercion (Watermeyer et al., 2021).

The urgent change from physical course delivery to digitalized learning and the forced digitization of teaching process to delivering courses have demanded new experience with innovative thinking for both teaching and learning communities. (Gamage et al., 2020) point to the growing importance of how technological advances allow online delivery to function in other ways, challenging teacher identity, governance, and trust on assessment during the process while having the threat of new pandemic. A new survey by British academics from a variety of disciplines and backgrounds has identified a multitude of “ailments” that have overshadowed ability of cost management in the context of urgent digitalized course teaching and learning (Watermeyer et al., 2021). These tribulations are to remain for some period. They cause unexpected impact on “learner enrollment”, “country income achieved by

---

\* Corresponding Author: E-mail - [malthusha@gmail.com](mailto:malthusha@gmail.com)

international intakes”, “country economy”, “resilience of higher education opportunities of education market” and “teaching assignment market” (Watermeyer et al., 2021).

## 2. AIM OF THE STUDY

The aim of the study is to obtain students’ perceptions and experience related to online course delivery due to Covid -19 pandemic in the universities of Sri Lanka and identify measures of innovative implementations for maximizing the opportunities.

## 3. RESEARCH OBJECTIVES

- To identify how Covid-19 has affected the learning process of undergraduates in Sri Lankan Universities.
- To examine undergraduate students’ perceptions of online learning during Covid-19 lockdown period.
- To identify measures for improvement of online course delivery for undergraduates in the university system of Sri Lanka.

## 4. METHODOLOGY

This study used a mixed research methodology. It is a research method that combines quantitative and qualitative methods that can be used together in research activities to obtain more complete, reliable and objective data.

The sample consisted of sixty students from five universities in Sri Lanka. Of the 60 students, 24 were men and 26 were women. Their ages ranged from 18 to 25, with an average of 21. A total of 60 participants were undergraduates. Students have participated in various degree programs such as Bachelor of Software Technology, Bachelor of Educational Technology, and Bachelor of Arts in English, Bachelor of Science in Computer and Information Systems, Bachelor of Science in Green Technology, Bachelor in science. Doctorate in Engineering Sciences, Bachelor of Computer Science and Bachelor of Fine Arts.

The students’ understanding of digitalized learning was taken by 15 responses while three personal detail responses were included in the survey. It used two open-ended questions on merits and demerits of digitalized learning. The response options consisted of predetermined options: agree, disagree, and neutral. The motive of the survey was not to collect psychology concerned data and therefore no proven scientific tools were used in the survey. As a result of existing pandemic, the investigation was administered online with the support of Google Forms. Data analysis had to be performed using MS Excel.

## 5. RESULTS AND ANALYSIS

### 5.1. Preferred Mode of Teaching

The results of this study indicate that physical learning is attracted more interest than digitalized online learning due to more moving and interaction opportunities, socialization, personal happiness and total quality of the task.

The study included questions assessing two aspects: online classes versus physical class room and individual experience. The responses of the survey showed that 82% of students said they preferred the physical teaching learning process over the online mode. Only 18% preferred online courses, as shown in Figure 1.



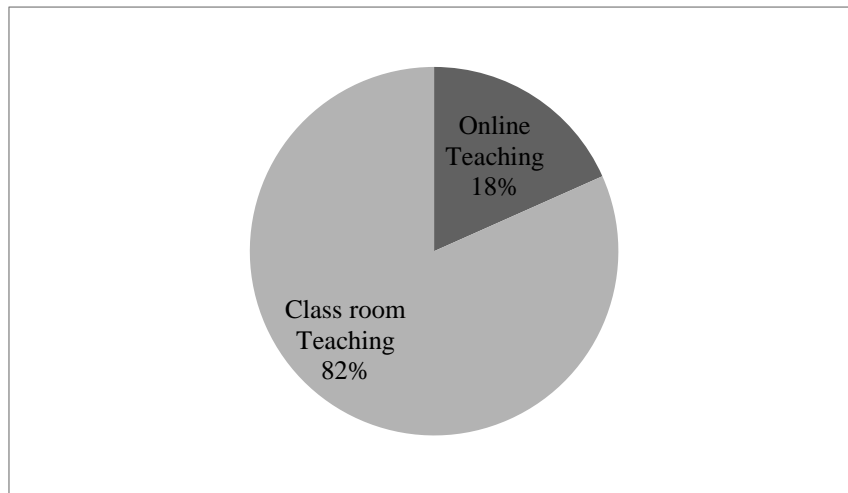

Figure 1: Preferred Teaching Method

### 5.2. Online Versus Class Room Teaching

When asked about the issues students typically face during online classes, what are the negatives of digital online classes, the majority (70% of the sample) indicated technical problems such as lower level network connection, electricity outages, internet access issues, low quality of electronic input, lack of communication between classes and difficulty re-entering the system, as shown in Figure 2. It showed that 83% of the total population said that online courses are less interactive, there is no proper interaction between sender and receiver and thus creating participation difficult. Thus, the online courses, in their opinion, were less lively, did not have a friendly atmosphere and social interaction.

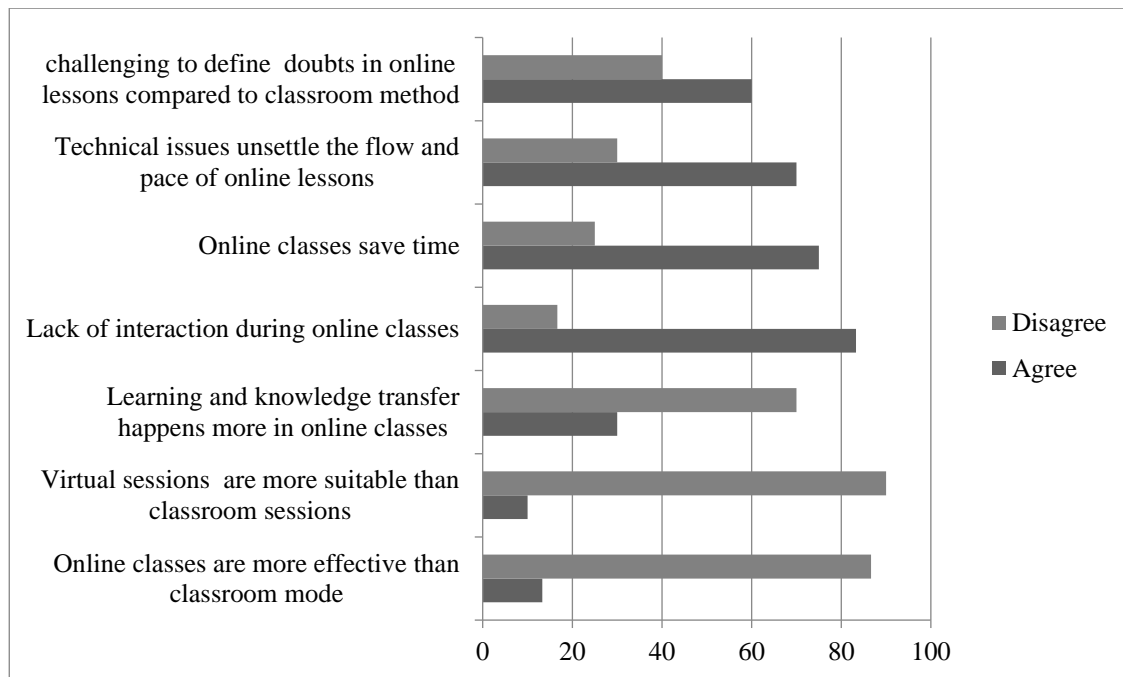

Figure 2: Online vs. Class Room Teaching

### 5.3. Students' Perceptions on Online Sessions

- i. Irrespective of the present generation's awareness of new technologies, the results further indicate that a large part of the sample said that on occasions they realized that due to their incapacity of handling in computer science, they were uncomfortable using online sessions. It showed that 60% of the population reported having difficulty concentrating during online lessons. It was found that there were more distractions at home, the lack of a structured learning environment did not prevent students from concentrating during the lesson. It found that 35% of the total population said online

courses are very tiring to perceive and master, in the situation when it comes to practical topics in lack of clarity of concept, lack of format or structured schedule. There are too many items scheduled for a day, they said, making it difficult. In the case of online courses, 15% of them felt a lack of motivation and interest. They felt like virtual sessions made them less serious and just took classes to attend and got uninterested and lazy. Some of the other problems indicated were high cost and accessibility matters. The responses indicated that online courses increased their spending due to frequent recharging of data. Students reported various physical problems due to online lessons. The constant use of cell phones and headphones causes problems such as eye strain and pain, ear pain, back pain and headaches, they said. They felt stressed and stressed physically and mentally. Students reported constant pressure to complete homework, which caused them significant stress. They felt that no education or knowledge gathering was really happening.

- ii. Analyzing the positive aspects of online courses, most came to the conclusion that it was a time saver as it can be done at home, saving time on travel and there is no need to rush to get to university. Other positive points were also reported: faster completion of the program, registration of lessons made it possible to come back to it later. Classes can be taken anywhere, anytime, giving flexibility.

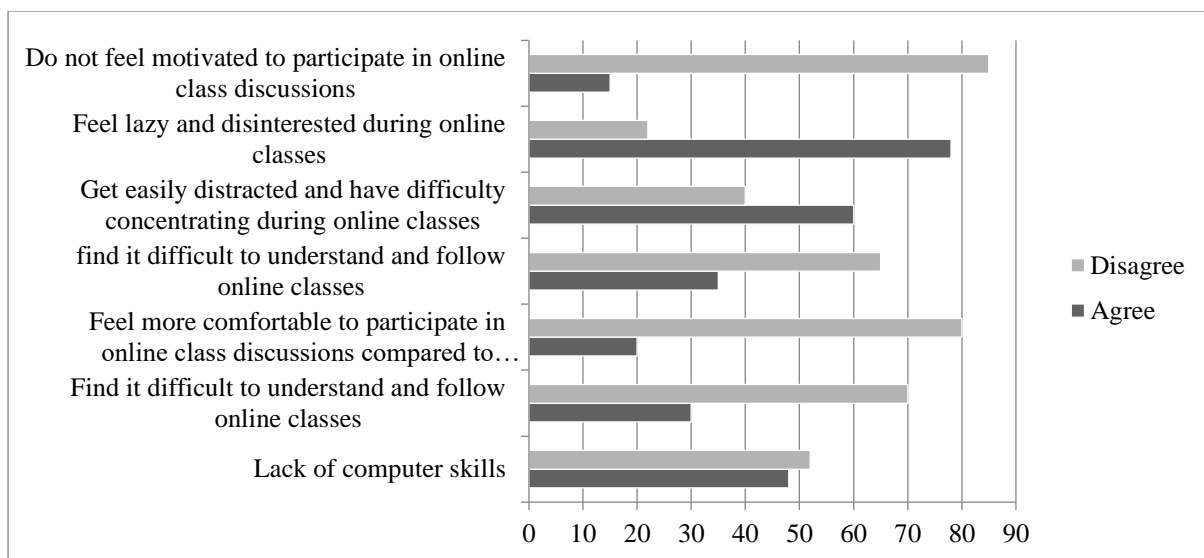

Figure 3: Online V/S Classroom Teaching Mode

#### 5.4. Common Problems with Online Learning

The respondents' views to general problems with digitalized learning can be presented as lower interest, lack of broadband access for learners living in far corners of the country, internet speed and cost and a hindrance of timely exchange of course related papers by both parties of the process. The constraints in the availability of learning tools like notebooks, tablets and smartphones to access the Internet and view documents online, time constraints to complete online tests are causing disturbances. Difficulty in learning practical subjects, lack of effective communication and feeling of loneliness were also common issues.

## 6. CONCLUSION

The COVID-19 outbreak has negatively impacted student education, including health, economic and social relationships. Measures such as social distancing, quarantines and school closures to reduce the transmission of the disease have had a significant impact on students' academic performance.

It has shown that learning disruptions, difficulties in social interaction, physical and mental health issues and the economic crisis caused by the COVID-19 epidemic have had contradictory consequences on the academic and educational behavior of students and academics.

The impact of the coronavirus pandemic varies from country to country, but in an educational environment, it is imperative to take action to protect young students with equal attention to all. Their

health must be indirectly taken care of with the greatest care. In this regard, consideration should be given to providing students with equal and non-discriminatory conditions, educational opportunities, equal learning for all students, protecting students with different vulnerabilities and taking advantage of associated opportunities for reorganizing the educational process. Priority should be given to reorganizing the educational process through a system of forming groups of students, teachers and people outside the education system to determine responses to current emerging needs.

The challenge is to focus on the intersections and productive potential of e-learning and traditional on-campus learning, and how they can collaborate more effectively to achieve learning outcomes and provide opportunities more equal to different students.

## 7. IMPLICATIONS AND RECOMMENDATIONS

It is recommended that to better manage academic integrity in the situation of digitalized course delivery and evaluation in the presence of the pandemic, faculty and staff be assisted with Institutional requirements and facilities that provides motivational support to faculty. The provision of resources and training is paramount for raising awareness and disseminating information on policies, practices, academic integrity expectations, disciplinary measures and development tools to mitigate academic misconduct. Likewise, professional development is essential for universities to be able to identify and respond to urgent needs. Appropriate attention should be given to areas of conflict of interest reduction in distance online delivery, design assessment criteria and innovative assessment tasks help students understand expected learning outcomes and encourage them to adopt a mutually reinforcing evaluation approach.

In addition, the factors below are highlighted for immediate attention by authorities for swift implementation.

- Universities should provide online learning facilities with uninterrupted course material accessibility.
- Provide students with electronic devices such as computers and tablets to access the Internet.
- Improve internet speed and provide cheaper or even free internet plans during a pandemic.
- Deliver capacity building of teachers on latest online knowledge.
- Improving the way of learning to encourage students to learn and involve them in online learning.
- Hands-on learning using interactive tools such as video and 3D animation is significantly more effective than textual media such as power point and pdf.
- Arrange manageable online assets such as eBooks and hands-on training videos.
- Less class work can help reduce stress for students.
- Conduct online tests and assignments after each lesson to understating level of the student group.
- Course completion time to be expanded to make the task achievable.

## REFERENCES

- Gamage, K.A., Silva, E.K.D. and Gunawardhana, N., (2020). Online delivery and assessment during COVID-19: Safeguarding academic integrity. *Education Sciences*, 10(11), p.301.
- Kernohan, D., (2020). Which universities are moving to remote teaching. *WONKHE*: <https://wonkhe.com/blogs/which-universities-are-moving-to-remote-teaching>.
- Rapanta, C., Botturi, L., Goodyear, P., Guàrdia, L. and Koole, M., (2020). Online university teaching during and after the Covid-19 crisis: Refocusing teacher presence and learning activity. *Postdigital Science and Education*, 2(3), pp.923-945.
- Watermeyer, R., Crick, T., Knight, C. and Goodall, J., (2021). COVID-19 and digital disruption in UK universities: Afflictions and affordances of emergency online migration. *Higher Education*, 81, pp.623-641.
- Wolfinger, S., (2016). An exploratory case study of middle school student academic achievement in a fully online virtual school. Drexel University.

# Propensity among the Undergraduates to Use Mobile Phones and its Impact on Academic Activities; A Case Study

Ravindra Koggalage<sup>\*1</sup>, M.A.A.S. Nazik<sup>2</sup>

<sup>1</sup>Faculty of Engineering Technology, University of Vocational Technology, Sri Lanka

<sup>2</sup>Department of Education and Training, University of Vocational Technology, Sri Lanka

## ABSTRACT

*Mobile phones are considered indispensable in daily life. However, its overuse can be harmful to the body and mind, especially for young people. Undergraduate research has many reports on high-impact issues related to mobile phone use, but few studies have been conducted on students at vocational or technical colleges. The purpose of this study is to determine undergraduate views on mobile phone use, learning processes, social interactions, entertainment, and their impact and support on emergencies. As a case study, we use structured questionnaires to survey students at selected vocational and technical colleges. Participants from three different student groups (2017/2018 batch, 2018/2019 batch, 2019/2020 batch) were randomly selected and 68 students responded to this survey. The survey also aims to investigate whether they share their phone with others. The results show that the behavior of students using mobile phones in student education is positive. The most serious negative consideration is that students can deceive the use of mobile phones, which can distract students. According to a survey, 87% of college students have more than three years of views on mobile phone use.*

**Keywords:** *Impact on Studies; Mobile Phone Usage; Undergraduates.*

## 1. INTRODUCTION

Today, mobile phones have become an integral part of our daily lives, whether you are at home, going to college, or doing other daily activities. Even the casual view of today's college students will find that mobile phones are used explicitly and secretly in a variety of possible campus living environments (including classroom environments) (Hossain, 2019). Advances in technology have made mobile phones a basic tool for communication and communication in the 21st century. The rapid development of multifunctional innovation has coordinated many parts of modern life-influencing the way we disseminate, access data, obtain information and learn. This measurement highlights the growing ownership and use across different market segments and countries (Pouster, 2016).

Many future researchers in this area have studied different groups of people who have a positive and negative relationship between smartphone addiction and educational activities (Lepp et al., 2014). By observing this relationship, we can see that smartphone addiction has a negative impact on college students' academic performance. Smartphone addiction has a positive impact on life satisfaction, but it also has a negative impact on academic performance (Samaha et al., 2016). After much research, there is still confusion as to whether smartphone addiction is beneficial to a student's life and whether it has a negative or positive impact on a student's academic performance. The current research consists of students from vocational colleges and technical colleges.

The purpose of this study is to:

1. Determine the impact of mobile phone use on undergraduate research
2. Identify the factors that lead to increased mobile phone usage
3. Understand college students' perceptions and reactions to mobile phone use
4. Impact on learning activities.

---

\* Corresponding Author: E-mail - [koggalage@yahoo.com](mailto:koggalage@yahoo.com)

## 2. LITERATURE REVIEW

About 31% of the world's population uses mobile phones as a communication medium. Motorola (as cited in Townsend, 2002) pointed out that the popularity of mobile phones is the fastest technology in history. This rapidly growing and widespread communication technology and media has important social background and influence.

Since most of the first use of smartphones is college students, we will discuss the factors that influence college students' smartphone usage behavior and early adopters of smartphones (Lee et al., 2014). Their focus is on the natural impact of smartphone adoption on college students. They also have a variety of factors such as self-development, self-survivability, product decision-maker attitudes, product decision-making emotions, family influences, and other de facto factors (such as age and sexual orientation). We investigated the effects of the factors. A logic and probability selection model theoretically developed to study college student recruitment behavior for random applications. Survey data is used to empirically evaluate individual selected samples. Using Smartphones Faster than Other Students The main reasons college students use smartphones are the influence of friends, financial burden, and other family members. A total of 151 college students from two introductory communications courses at major Midwestern universities participated in the study (Lee et al., 2014).

Lepp et al. We investigated the relationship between mobile phone use, academic performance, anxiety, and life satisfaction among students at public universities in the Midwestern United States (Lepp et al., 2014). We collect 536 responses through a questionnaire consisting of four structures (statistics, mobile phone usage, anxiety, and life satisfaction) and measure academic performance through official university records. As a result, academic performance is negatively correlated with mobile phone use, anxiety is positively correlated with mobile phone use, and academic performance is positively correlated with life satisfaction, but anxiety and life satisfaction. You can see that the relationship is relatively small. To increase the generality of this study, researchers instructed future researchers to include other populations (high school, graduate) from other regions (Lepp et al., 2014).

Hawi et al on educational performance and smartphone use of students at the University of Notre Dame in Lebanon. The results show that there is a negative correlation between smartphone use and academic performance, according to a study by Hawi et al., 2016. Their survey reviewed 293 responses, including two of the 33 parts (statistics and smartphone application criteria), and measured GPA through official university records. Baker et al. stated that faculty and staff need to solve the problem of using electronic devices in the classroom (Baker et al., 2012). Current theory does not show this, but it does provide an important way to identify electronics in the classroom.

## 3. RESEARCH METHODOLOGY

This study was conducted on students from vocational colleges and technical colleges. This research strategy is a common research design used to collect large amounts of data from large populations in an economical way. Therefore, this study is aimed at more people, and this study method is considered appropriate and can improve the high reliability of the study results. In addition, the decision was made using a voting survey used in Google Forms that facilitates data comparison.

The survey created a structured survey that included demographic information such as gender, age, and number of participants, mobile phone usage, and impact on academic activity. By contacting students selected from various batches online, they were informed about the survey and agreed to participate in the survey. A quiz link was sent to the student, who explained the steps to answer the question. Then ask the student to submit a completed Google Form. Use a self-managed process to collect information. That is, respondents read the question themselves and provide answers to more information about their mobile phone usage.

There are 300 undergraduate students in each batch, and the ratio of randomly selected students in this survey is 15: 300, which is 1:20. According to this survey, 15 students were randomly selected from each batch, including 31 female participants and 37 male participants. Selected students are between the ages of 20 and 33 and need to understand how smartphones are used, their impact on smartphone

learning activities, and the factors that lead to increased mobile phone usage in the faculty, and to investigate the impact of mobile phones. Ability to recognize and respond to the population of this study. Each participant was given a block marking method to avoid double responses.

This study uses a quantitative data collection method. Key data collection methods, such as surveys, are used to find stakeholders affected by the use of mobile phones in academic and / or non-academic ways. Therefore, in this study, we selected three batches of full-time students from vocational colleges and technical colleges. Each batch has about 300 students. Therefore, the ratio is 15: 300, so the information collected in this survey is 1:20. Students collect information about this survey.

The survey received 68 responses in two weeks. The 2017/2018 batch received 34 responses, the 2018/2019 batch received 18 responses, and the 2019/2020 batch received 16 responses. Therefore, all interviewees mentioned the batch (Table 1). As a survey, have the questioner submit to collect data via a Google Form. Therefore, the total number of responses analyzed is 68.

Table 1: Sampling respondents' details

	percentage	Responders
<b>2017/2018 Batch</b>	50%	34
<b>2018/2019 Batch</b>	26.5%	18
<b>2019/2020 Batch</b>	23.5%	16

The survey has been conducted using a Google Form, so it has been sent to college students. Samples were collected from college students representing the entire group of students. Use a Microsoft Office software package (such as Excel or PowerPoint) to display data and create graphic elements that display a visual concept of the information collected.

#### 4. RESULTS AND DISCUSSION

Collect data and calculate results using an easy way to draw percentages and charts using Google Sheets. A total of 68 respondents included 37 men and 31 women. As shown in Table 2, 54 of the 68 respondents were males (54.4%) and 31 were females (45.6%). 38 respondents (55.9%) were 23-25 years old, 16 (23.5%) students were 26-28 years old, 7 (10.3%) students were 20-22 years old, 6 (8.8%) The age group is students aged 29-31 and only one (1.5%) of the respondents is 33 or older. It is worth mentioning that all 68 respondents (100%) use mobile phones and smartphones. Table 2 provides detailed population distribution by gender, mobile phone usage, and smartphone usage.

Most interviewees state that they do not share their mobile phones with anyone (Table 2). There were some interesting qualitative answers about mobile phone sharing. All respondents who shared their cell phones said they shared their cell phones only with close family members. Only 5% of respondents said they did not answer.

When asked why they wanted to use their cell phones, many interviewees pointed out that they needed to stay in touch with family and friends and use their cell phones for emergencies and personal safety. 25 % of students said emergency use was the most important reason to buy a mobile phone, compared to 40% of students in the 2017/2018 batch. An interesting result is that 38% of students choose to "keep in touch with their parents" as the number one reason to buy a mobile phone, compared to just 8% of students in 2018/2019 (Table 2). Six respondents from the 2019/2020 batch countries cited reasons other than the designated highest rank. For example, free long distance (3 answers), easy / cheap contact with close family members (2 answers), taking pictures (1 answer).

Respondents were also asked to mention the time they spent using their mobile phones. A total of 86.8% (59) of students have been using mobile phones for more than 3 years (Table 2). The survey also sought to clarify common usage scenarios for interviewees on mobile phones. Always keep your phone as the highest rated utility display in all three batches (Table 2). Three batches of interviewees said they used

their mobile phones more often at night than late at night (50% and 34%, respectively) with 33.8% (23) of students use the phone late at night. 8.8% (6) of the students have mentioned that they used the mobile phone in the afternoon. Only 7.4% (5) of the students have mentioned that their least mobile phone used time is in the morning.

54.4% of respondents use mobile phones for about 4 to 6 hours a day, and 19.1% of respondents use mobile phones for about 1 to 3 hours a day. 17.6% of students use mobile phones 7-9 hours a day, and only 8.8% of respondents use mobile phones for 10 hours or more. 52.9% (36) of students agreed that mobile phones store more entertainment materials than learning materials (Table 2). 70.5% of participants said they use the mobile internet most often for entertainment. For 98.5% of students, more than half of the participants acknowledged that the main impact of academic performance on learning activities was related to academic performance. The majority of students (51 (75%)) suggested "for a while" and undergraduates recommended using smartphones. Twelve (17.6%) of the respondents never thought that they could not improve their academic performance without a mobile phone, only 5 (17.6%). 7.4%)) Accept that you can always improve your academic performance without using a mobile phone. According to the survey results, many participants want more undergraduate students to use smartphones, and they strongly oppose this proposal. The overall answer shows that undergraduate students use smartphones to offer different types of opportunities and abilities, as shown in Table 2.

Half of the 32 students (47.1%) said their academic performance deteriorated due to frequent use of mobile phones, 17 (25%) said they neglected their research, and 11 (11). 16.2%) showed carelessness from research among students. The seven least-used respondents (10.3%) said that mobile phone use affects learning habits and test scores. As shown in (Table 2), the least used time of the day is in the morning, with only 7.4% of time from college students.

General comments about students using mobile phones in our research (such as using mobile phones at university) can help you complete your homework or search for research notes. In some cases, there is no problem. Then immediately contact your friends and teachers to resolve any doubts. There is a mobile phone answer to studying at university. There are also mobile phone search answers and detailed homework, exams, clear learning questions, online learning (Google Classroom, Zoom, etc.), contact college friends and employees, college (holidays, reopening, etc.)

Table 2: Summary of Results

Questions	Questions Response Details	Response percentage	Number of Responses
<b>Response Batches</b>	2017/2018	50%	34
	2018/2019	26.5%	18
	2019/2020	23.5%	16
<b>Gender</b>	Male	54.4%	54
	female	45.6%	31
<b>Mobile phone usage</b>	Yes	100%	68
	No	0%	0
<b>Smart phone usage</b>	Yes	100%	68
	No	0%	0
<b>Age</b>	20-22 Years	10%	7
	23-25 Years	55.9%	38
	26-28 Years	23.5%	16
	29-31 Years	8.8%	6
	33 above Years	1.5%	1
<b>Shared usage mobile</b>	I do not share my mobile phone with anyone.	85%	58
	I share my mobile phone.	10%	7
	No answer	5%	3
<b>Highest ranked acquiring mobile phone</b>	To use in case of emergency or personal safety	Agree	38
		Strongly Agree	27
		Undecided	2

	For Academic Performance	Agree	32
		Strongly Agree	31
		Undecided	3
	To keep in touch with friends and other social contacts	Agree	32
		Strongly Agree	27
		Undecided	4
	To keep in touch with parents	Agree	27
		Strongly Agree	33
		Undecided	3
	For business reasons	Agree	32
		Strongly Agree	13
		Undecided	12
	For information access (phone numbers, internet, email, sports scores, etc.)	Agree	28
		Strongly Agree	34
		Undecided	3
	It offers good value	Agree	38
		Strongly Agree	15
		Undecided	7
	Privacy management (I use it to stay in touch with close friends and/or family; others call me on my landline)	Agree	32
		Strongly Agree	14
		Undecided	13
<b>Duration of usage / experience</b>	More than 3 years	86.8% (59)	59
<b>Highest ranked usage scenario</b>	All the time	66.2%	45
	To keep in touch no matter where I am,	14.7%	10
	To sleep with it next to my bed,	10.3%	7
	To sleep with my phone on or to turn it off when I go to bed.	8.8%	6
<b>Commonly reported time of use</b>	Morning	7.4%	5
	Afternoon	8.8%	6
	Evening	50%	34
	Late night	33.8%	23
<b>Hours a day using mobile phone.</b>	1-3 hours	19.1%	13
	4-6 hours	54.4%	37
	7-9 hours	17.6%	12
	More than 10 hours	8.8%	6
<b>More occupy stored materials</b>	Study materials	52.9%	36
	Non-Study materials	47.1%	32
<b>Common type of Internet usage</b>	Chatting	8.8%	6
	Entertainment	61.8%	42
	Other information	29.4%	20
<b>Accept smart-phone used for major role for learning</b>	Yes	98.5%	67
	No	1.5%	1
<b>Academic Performance using Mobile Phone</b>	Always	7.4%	5
	Sometime	75%	51
	Never	17.6%	12
<b>Mobile phone is affecting them academically</b>	Distracting from studies	16.2%	11
	Lack of concentration in studies	25%	17
	Affecting study habits and results in exam	10.3%	7
	Academic performance is decreased because of frequent of mobile phone	47.1	32
	Never	1.5%	1

This study aims to clarify the impact of mobile phone use on undergraduate studies of vocational and vocational school students. Today, mobile phones play the most important role in our lives. With keys and money, mobile phones have become a very common device that most people carry. By using a mobile phone, you can communicate anytime, anywhere, and become a career of self-expression and



self-awareness. Young people are accustomed to working on multiple jobs at the same time, and mobile phones are influencing communication between younger generations, influencing communication skills and self-expression. The new method of shorthand is becoming more and more popular among students.

There are signs that many aspects of the impact of mobile phone use are the same across batches. Staying in touch with parents and friends is the most highly rated environmental scenario for all batches. New mobile phone users have noticed that mobile phone use increases over time, especially in contact with friends and other social connections, over time in emergencies and personal safety. Another similarity between the three batches is that many respondents said they had their own phone, while many did not share the phone when they shared it. Very few interviewees said they would share it with their close family members, and three batches showed that mobile phones were used to communicate and share with friends and family.

The majority of respondents in all three batches said their mobile phone was their main mobile phone. This may be due to college students using their mobile phones as smartphones. Smartphone experience is compatible with all three modules, with over 89% of respondents in all three batches having over three years of mobile phone experience.

In all three batches, night is the most commonly used time for mobile phones. At night, about 50% of respondents say they use their mobile phones to stay on the university campus. The preferred place to receive a call is to contact family and friends, but it is interesting that many interviewees decide to contact their parents, especially as a factor. Most of the respondents who passed the undergraduate were in the 2017/2018 batch.

## 5. CONCLUSION

This study investigated the impact of mobile phone use on undergraduate courses at vocational and technical colleges. For this reason, relationships and interactions between smartphone addiction, smartphone self-efficacy, behavioral goals, and communication skills have been observed. Like teens, smartphone addiction is on the rise because it relies heavily on technology in every way. Therefore, a consistent and detailed study is needed to determine whether smartphone addiction is beneficial to students or has a positive impact on academic performance. While there are some good advantages to using a mobile phone, it is difficult to underestimate its disadvantages. They believe that overuse of smartphones is the main reason for their poor performance. I also feel the negative effects of overuse of mobile phones. Current research aims to raise participants' awareness of the effects of smartphone abuse and how it affects their educational activities. Universities and junior colleges can raise student awareness of overuse of mobile phones, which can adversely affect their research.

## REFERENCES

- Acharya J.P., Acharya I., Waghrey D., (2013). A study on some of the common health effects of cell-phones amongst college students, *J Community Med Health Educ*, 203-214.
- Agha E., (2018). 150 times a day: study shows Indian students' alarming smartphone addiction. [cited 2019 Feb 28]. <https://www.news18.com/news/india/accordingto-new-study-students-check-their-mobile-devices-asmany-as-150-times-in-a-day-1720539.html>
- Aljomaa, S. S., Alqudah, M. F., Albursan, I. S., Bakhiet, S. F., & Abduljabbar, A. S., (2016). Smartphone addiction among university students in the light of some variables, *Computers in Human Behavior*, 61, 155–164.
- Baker WM, Lusk EJ, Neuhauser KL, (2012). On the use of cell phones and other electronic devices in the classroom: Evidence from a survey of faculty and students, *Journal of Education for Business*. 1;87(5):275-289.
- Bragdon RA, Dowler K., (2016). College student technology use and academic performance, *International Journal of Humanities & Social Sciences* 6(1):12-22.
- Campbell M., (2005). The impact of the mobile phone on young people's social life. In: Bailey C, Barnett K, eds. *Social change in the 21st Century Conference Proceedings: Queensland University of Technology, Australia*, p.1-14.

- Carlson, P. J., Kahn, B. K., and Rowe, F., (1999). Organizational Impacts of New Communication Technology: A Comparison of Cellular Phone Adoption in France and the United States. *Journal of Global Information Management*, 7(3), 19-29.
- Cha SS, Seo BK., (2018). Smartphone use and smartphone addiction in middle school students in Korea: Prevalence, social networking service and game use, *Heal Psychol Open*;5(1).
- Chiu, S.I., (2014). The relationship between life stress and smartphone addiction on Taiwanese university student: A mediation model of learning self-Efficacy and social self-Efficacy, *Computers in Human Behavior*, 34, 49-57.
- Davey S, Davey A., (2014). Assessment of smartphone addiction in Indian adolescents: a mixed method study by systematic review and meta-analysis approach, *Int J Prev Med*;5(12):1500-1511.
- Emanuel R.C. *Coll Stud J.*, (2013). The American college student cell phone survey.;47(1):75-81. <http://ovidsp.ovid.com/ovidweb.cgi?T=JS&PAGE=reference&D=psyc10&NEWS=N&AN=2013-10664-008>.
- Goswami V, Singh D.R., (2016). Impact of mobile phone addiction on adolescent's life: a literature review. *International Journal of Home Science*;2(1):69-74. <http://www.homesciencejournal.com>
- Guynn, J., (2009). "Facebook's WhatsApp hits 900 million users, aims for 1 billion". *USA Today*.
- Hashem ME., (2015). Impact and implications of new information technology on Middle Eastern youth, *Global Media J: American Edition*;8(14):1-25.
- Hawi, N. S., & Samaha, M., (2016). To excel or not to excel: Strong evidence on the adverse effect of Smartphone addiction on Academic performance, *Computers & Education*, 98, 81–89.
- Hofvenschiold, E., (2003). Determining Cultural Issues in Attitude to and Use of Mobile Phones. *Proceedings of the German Chapter of Usability Professionals*, 171-174.
- Hossain M., 2019. Impact of mobile phone usage on academic performance. *World Scientific News*, 118:164-80.
- Lee, J., Cho, B., Kim, Y., & Noh, J., (2014). Smartphone Addiction in University Students and Its Implication for Learning. *Emerging Issues in Smart Learning*, 297–305.
- Lepp, A., Barkley, J.E., & Karpinski, A. C. (2014) The relationship between cell phone use, Academic performance, anxiety, satisfaction with life in college students. *Computer in Human Behavior*, 31, 343-350.
- Johnson S, Natarajan R., (2017). Academic use of smart phones among the students of business schools in uae -a study. *KIIT Journal of Library Information Managment*; 4:32-36.
- Jumoke S, Blessing O., (2015). Analysis of mobile phone impact on student academic performance in tertiary institution. *Int J Emerge Technol Adv Eng*;;5(1):2250-2259.

## Author Index

- Abeywickrama T.D.C.S.: 82  
 Nandhakumar N.: 95  
 Aathawan M.: 55  
 Abesinghe A.M.N.L.: 356  
 Abeyakoon D.C.M.: 192  
 Abeywickrama C. J.: 314  
 Akalanka R.A.K.P.: 9  
 Alahapperuma K. G.: 76, 95  
 Amarasekara K. A. I. M.: 185, 381  
 Amarasinghe Kishan Chaleendra: 501  
 Andawala Thilini: 300  
 Bamunuarachchi B.A.V.M.: 90  
 Bandara B.G.R.R.: 248  
 Bandara D.M.D.S.: 44  
 Bandara P.W.L.Y.R.: 9  
 Banu M.R.R.: 125  
 Barathy M.: 17  
 Beligala D.H.: 320  
 Bulathge B.M.I.M.B.: 82  
 Charithangi M.P.: 248  
 Chathurangi J.W.P Dilsha: 211  
 Danthanarayana C.P.: 144, 160, 381  
 Danushka S.A.N.: 441  
 Dayananda D.U.: 242  
 De Silva J.H.I.G.: 356  
 Denagama T.: 192  
 Dharmarathna B.V.D.R.: 139  
 Dharmendra D.: 227  
 Dias M.P.S.P.: 424  
 Dilhani M.N.: 273  
 Dissanayaka D.M.S.L.: 17  
 Dissanayake M.M.K.S.: 170  
 Edirisinghe U.A.S.K.: 328, 335, 347  
 Ediriweera Sampath: 63  
 Eshana H. W. A.: 55  
 Farwin M.N Nafra: 406  
 Fazana S.F: 144  
 Gamage Iresha: 508  
 Gamage Padma Shanthy Y.: 411, 417, 516  
 Gamage R. C.: 130  
 Ganegoda Dilshan: 49, 82  
 Gimhani K. D. M.: 234  
 Goonathilake M.D.S.W: 248  
 Gowthami M.: 125  
 Gunarathna I. G. P. Darshana: 76  
 Gunasekara Indrachapa: 398  
 Gunawardana A. A.: 424  
 Gunawardena Diyanada J.: 117  
 Hearth H.M.R.G: 36  
 Herath H.M.E.C: 49  
 Herath H.M.T.P: 248  
 Herath Jayathree: 398  
 Herath Malani: 474  
 Illankoon Prasanna: 453  
 Imbulegama Manoj: 361  
 Indikatiya I.H.P.R.: 273  
 Indrajith S. D. D. N.: 314  
 Jayalath Chandana: 288, 300, 508  
 Jayasanka K.G.M.: 9  
 Jayasekara B.M.T.D.: 139  
 Jayasekara J.M.C.M.: 366, 372  
 Jayasekara K.P.I.S.: 152, 381  
 Jayathilake M.A.D.J.: 160  
 Jayathilake S.P.A.R.S.: 22  
 Jayathunga D.N.: 102  
 Jayathunga Dineth D.: 2  
 Kalansooriya K. T. D.: 76  
 Kalansooriya Pradeep L.: 125  
 Kanakarathna Praveen: 347  
 Kanchana Ishani: 70  
 Kanchana Asitha: 288  
 Kanthi J. K.: 198  
 Karunarathna J. A. M. Buddhima: 424  
 Karunasinghe N.S.: 273  
 Karurarathna Tharindu: 70  
 Koggalage Ravindra: 2, 28, 55, 488, 549  
 Kularatne L.W.S.: 461, 537  
 Kumara H.S.N.: 44  
 Kumaradasa G.G.W.E.: 417  
 Kumarasingha S.L.T.: 328  
 Kumarasiri G.D.T.N: 90  
 Kuruppu M. P. C.: 265  
 Lakmal R. M. C.: 55  
 Lakmal Thilina A. A.: 82  
 Lakmini G.W.A.S.: 328, 335  
 Madhushani D.M.P.: 144  
 Maduranga M.W.P.: 22  
 Madusanka O.W.S.: 320  
 Madushanka D.M.T.: 102  
 Madushanka H. A. Gayan: 501  
 Malwatta T. K.: 537  
 Manathunga Dilan: 70

- Manathunge Y.S.: 453  
 Marasinghe M.K.I. :22  
 Mithulaa Pragash: 411  
 Munasinghe J. C.: 437  
 Nandapala Kasun: 242  
 Narampanawa Viraj: 49  
 Nawanjana D. K. Chathumi: 453  
 Nazik M.A.A.S.: 549  
 Nimalka K.D.C: 256  
 Nirosanth S.: 179  
 Oshadie N.L.B.: 467  
 Paranamanaana T. R.: 76  
 Pathirana A.P.R.P.: 381  
 Pathirana H. P. A. I.: 110  
 Pavucsan M.: 125  
 Perera Madhavi: 44  
 Perera P. L.: 234  
 Pirashanthan M.: 530  
 Pirathusha K.: 2  
 Prananda Suranmali: 431  
 Premakeerthi W. A. C. R.: 294  
 Premarathna Dhanusha U. A.: 170  
 Premarathne D. S.: 447  
 Pushpakumara K. A. N. I.: 17  
 Rajapaksha R. M. P. D. K.: 160  
 Rajakaruna R. M. A. C.: 516  
 Rajapaksha K. G. N. P.: 219  
 Rajapaksha U. G.: 205  
 Ranasuriya L. H. Dilini. L.: 447, 467, 482, 523  
 Ranatunga N.P.: 342  
 Rangana S.B.C.: 424  
 Rasanjana Hasaranga K.A.H.: 28  
 Rathnasena B.B.L.R: 256  
 Rathnaweera R.P.S.K.: 139  
 Rathnayake P.P.A.J.: 320  
 Rathnayake W.M.S. Sulakshi: 501  
 Rifkhan M.I.M.: 110  
 Sachintha S.: 90  
 Safzath Z.A.M.: 110  
 Samarakoon S.M.C.S.: 366  
 Samarasinghe H. G Dayal Shamin: 211  
 Sandaruwan A.J.T.: 44  
 Sarfa M.M.N.: 441  
 Senarathne K.H.R.A.: 22  
 Seneviratne S.R.M.P.: 2, 28, 55, 219, 488  
 Sewwandi B.A. Asika: 474  
 Siyambalapitiya S.C.D.: 130  
 Somaratne G.M.: 320  
 Sondarangallage D.A. Sanjeeva: 9, 36  
 Srimal H.A.J.: 28  
 Srivishagan V.: 265, 294, 495  
 Sriyani G.T.W.: 152  
 Sumathiratna Chamila: 281  
 Suraweera D.D.D.: 256, 281, 461  
 Thalpage R.: 265, 294, 495  
 Tharaka P.D.M: 49  
 Thathsarani M.L.P.: 335  
 Thusyanthan S.: 227  
 Thuvaragan Somasundaram: 488  
 Ulpenge U.M.R.B: 82  
 Uruthiran Sivachelvy: 398  
 Uruthiran Thushana: 63  
 Wanniarachchi Shalika N.: 205  
 Wansapala M.A.J.: 328, 335  
 Warahena Aruna: 90  
 Wasala W.M.T.M.: 22  
 Weerarathna G.V.P.I.: 17  
 Weerasekera T.D.: 273  
 Wettasinghe Jayalal: 70, 406, 467  
 Wickramasinghe Yasintha: 308  
 Wijekoon M. M. J. O.: 308  
 Wijesingha A.W.K.G.: 482, 523  
 Wijewardane Anusha: 281  
 Wimukthi G.G.R.: 320

INTERNATIONAL  
RESEARCH  
SYMPOSIUM 2021

INTERNATIONAL  
RESEARCH  
SYMPOSIUM 2021

INTERNATIONAL  
RESEARCH  
SYMPOSIUM 2021

INTERNATIONAL  
RESEARCH  
SYMPOSIUM 2021

INTERNATIONAL  
RESEARCH  
SYMPOSIUM 2021

INTERNATIONAL  
RESEARCH  
SYMPOSIUM 2021

INTERNATIONAL  
RESEARCH  
SYMPOSIUM 2021

INTERNATIONAL  
RESEARCH  
SYMPOSIUM 2021

INTERNATIONAL  
RESEARCH  
SYMPOSIUM 2021

INTERNATIONAL  
RESEARCH  
SYMPOSIUM 2021

University of Vocational Technology  
No. 100, Kandawala, Rathmalana.  
0112-630700  
[www.uovt.ac.lk](http://www.uovt.ac.lk)



ISSN 2602-8778

INTERNATIONAL  
RESEARCH  
SYMPOSIUM 2021

INTERNATIONAL  
RESEARCH  
SYMPOSIUM 2021